



Picture is a representation of actual product

Approvals



Order Information: NTEP Certified

Load Rating	Part #	Est. Weight	Price
NTEP Certified			
0.5 T	36190	2 lb	Consult
1 T	36191	2 lb	Consult
2 T	36192	3 lb	Consult
3.5 T	36193	3 lb	Consult
5 T	36194	3 lb	Consult
10 T	177263	6 lb	Consult
OIML			
0.25 T	126714	2 lb	Consult
0.5 T	126715	2 lb	Consult
1 T	126716	2 lb	Consult
2 T	126717	3 lb	Consult
3.5 T	126718	3 lb	Consult
5 T	126719	3 lb	Consult
10 T	177262	3 lb	Consult

Replacement Rocker Pin Set*

Load Rating (Per Module)	Part #	Price
250 kg to 1 T	170875	Consult
2 T to 5 T	170876	Consult
10 T	170877	Consult

*Kit includes upper cup, rocker pin and grease

Dimensions

Rated Capacity	D	D1	D2	D3	H	H1	H2	H3	T
T/in									
0.25 to 1	2.76	3.15	3.84	0.40	0.99	0.60	0.04	0.37	M6 (3 x 120°)
2 to 5	2.76	3.15	3.84	0.60	1.18	0.79	0.24	0.33	M6 (3 x 120°)
10	3.26	3.74	4.42	0.98	1.37	0.58	-	0.39	M6 (3 x 120°)

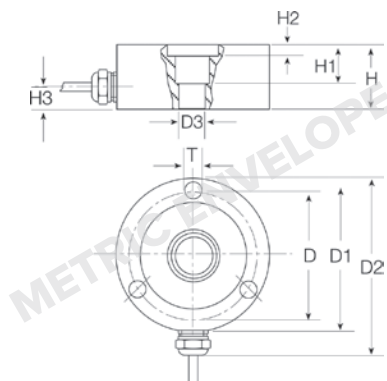

Weigh Module Available

RICE LAKE WEIGHING SYSTEMS
RLC..... page 65

Specifications

- Full Scale Output:**
2.0 mV/V
- Output Resistance:**
1,025 (± 25) ohm
- Input Resistance:**
1,110 (± 50) ohm
- Material/Finish:**
Stainless steel
- Temperature:**
Compensated range
14 °F to 104 °F (-10 °C to 40 °C)
Operating range
0 °F to 150 °F (-18 °C to 65 °C)
- Seal Type:**
Hermetically sealed, IP66/68
- Safe Overload:**
150% full scale
- Safe Sideload:**
100% full scale
- Rated Excitation:**
5 to 10 VDC (15 V maximum)
- Combined Error:**
0.02% full scale
- Insulation Resistance:**
5,000 megohm
- Cable Length:**
5 m
- Cable Color Code:**
Pink +Excitation
Grey -Excitation
Brown +Signal
White -Signal
- Warranty:**
One-year limited
- Approvals:**
FM
OIML
NTEP

