

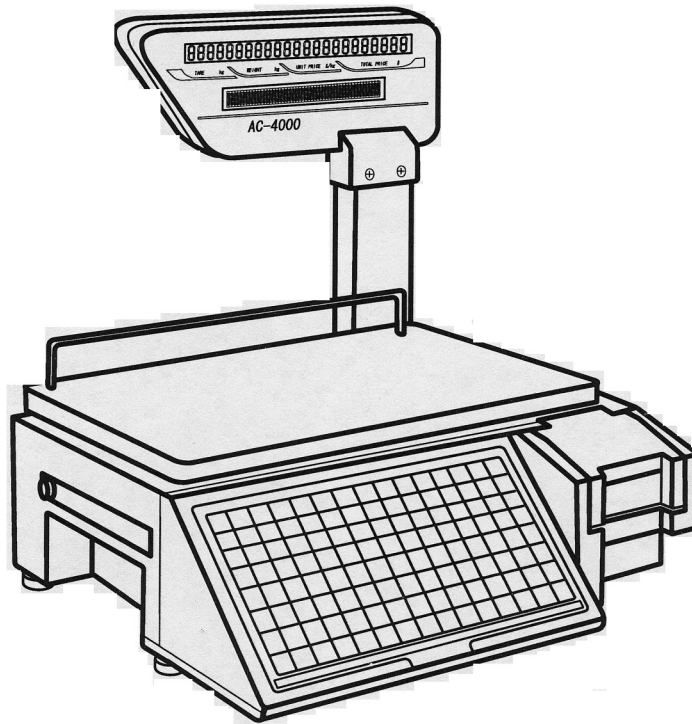

System Scale Printer  
**AC-4000** B/E  
**SERVICE MANUAL**



**IMPORTANT**

- Do not carry out installation, operation, service, or maintenance until thoroughly understanding the contents of this manual.
- Keep this manual available at all times for installation, operation, service, and maintenance.

**ISHIDA CO., LTD.**

Manual No. 0181A

PN 83928

You can help improve this manual by calling attention to errors and by recommending improvements. Please convey your comments to the nearest Ishida Company regional representative. Thank you!

**Copyright © 2002 by Ishida Co., Ltd. All Rights Reserved.**

No part of this manual may be reproduced in any form, by mimeograph or any other means, without written permission of the publisher.

 **SERVICE SAFETY**

**For correct maintenance, and to prevent accidents, please adhere to the following items during service.**

- Ensure that the power switch is OFF before any maintenance work and remove the power cable from the main power outlet.
- Keep the machine surroundings clean and tidy. Take additional care, especially during disassembly, not to leave screws etc. inside the machine as this may lead to serious injury.
- Do not pull internal wiring cables as cable breaks, poor contact, etc. may take place. Always hold the connector end before removing. Take special care with thermal head cable, where poor contact may lead to damage.
- Take care when cleaning thermal heads and print heads, as these are easily damaged.
- There are precautions relating to assembly and adjustment parts. Read and understand the manual thoroughly before attempting maintenance.

 **SAFETY CONSIDERATIONS**

**For safe operation, the following safety considerations must be observed.**

**Grounding**

This machine requires protective grounding for safe operation. To avoid potential shock hazards, a protective grounding conductor for the machine must be securely connected to the main grounding provision by qualified service personnel.

**Do not remove covers or enclosures**

To avoid personal injury and shock, do not open or remove any covers or enclosures of the machine unless specified in the manual.

**Do not perform unspecified maintenance**

For your personal safety, do not perform any maintenance procedures which are not specified in the manual.

**Disconnect power supply before servicing**

To ensure your personal safety, disconnect the power supply before servicing.

## ⚠ CAUTIONS FOR USE

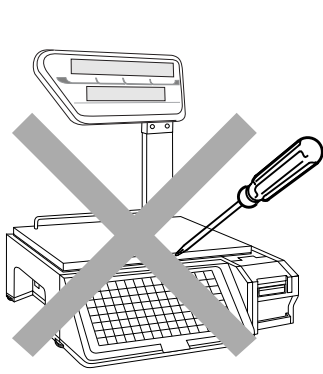

▶ Do not disassemble the machine.

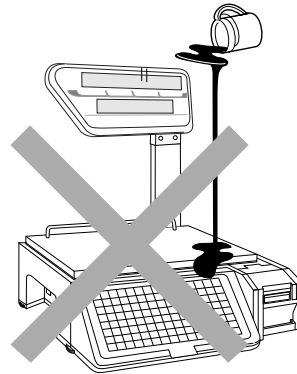

▶ Do not allow any liquids to come into contact with the machine.

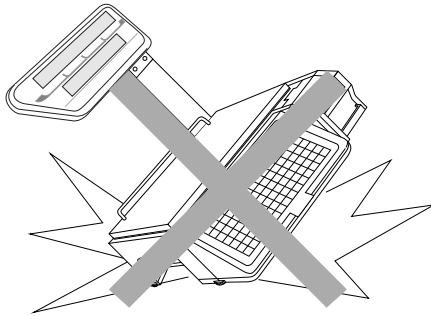

▶ Do not drop or apply a strong shock to the scale.

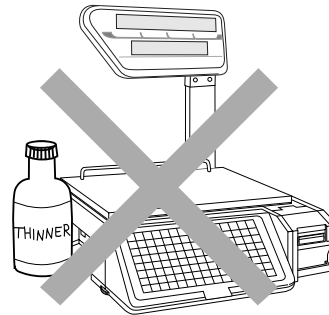

▶ When cleaning the machine, only use a soft dry cloth or a cloth wetted with a neutral cleanser. Never use thinner or other volatile liquids.

### Power Supply

- Use the appropriate voltage after referring to the specification plate located on the machine.
- Use a dedicated power source.  
(Voltage fluctuation may cause the machine to malfunction)

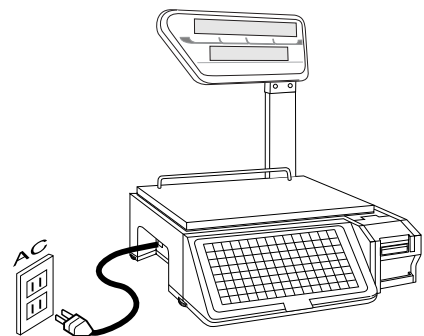

## ⚠ CAUTIONS FOR INSTALLATION

### Avoid the following areas when installing the machine

- Areas subject to high temperatures or high humidity
- Areas exposed to direct sunlight
- Areas where water or other liquids are easily spilled on the machine
- Areas subject to excessive vibration or unstable surfaces
- Areas exposed to direct cold air
- Areas subject to low temperatures

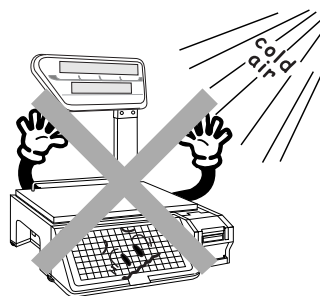
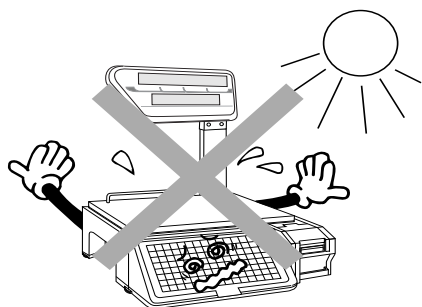

- Areas subject to a lot of dust or dirt
- Areas with large voltage fluctuations
- Areas where the scale is not level

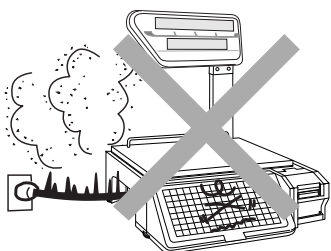

### Level adjustment

- Always ensure that the machine is level. If the machine is not level, weighing may not be accurate.
- Adjust the machine to a level position using the four level adjustment feet located on the bottom of the machine, until the bubble is completely centered in the round level indicator.

Level adjustment foot

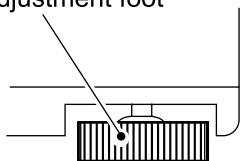

Level indicator

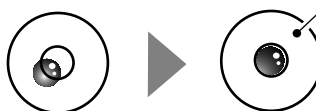

# Contents

<b>CHAPTER 1 OVERVIEW .....</b>	<b>1-1</b>
1.1 Appearance and Name of Each Part.....	1-1
1.2 Display .....	1-1
1.3 Key Sheet .....	1-2
1.4 Printer .....	1-2
1.5 Main Specifications .....	1-3
1.6 Exploded Drawing .....	1-4
<b>CHAPTER 2 INSTALLATION .....</b>	<b>2-1</b>
2.1 Packed Goods .....	2-1
2.2 Installation Environment .....	2-2
2.3 Assembly .....	2-2
2.4 Weigh Platter Installation.....	2-3
2.5 Label Loading .....	2-3
2.6 Power Cable Connection.....	2-4
2.7 Turning Power Switch “ON” .....	2-4
2.8 Customer’s Specification Setup .....	2-5
(Initialization, Setup, and Registration) .....	2-5
2.9 Normal Mode Display .....	2-6
2.10 Label Batch Print Mode .....	2-7
2.10.1 Basic operation .....	2-7
2.10.2 Additional functions.....	2-7
2.10.3 Label batch printing on continuous paper .....	2-8
2.11 Scroll Message Display .....	2-9
2.12 Campaign Function .....	2-9
<b>CHAPTER 3 TEST MODE.....</b>	<b>3-1</b>
3.1 Test Mode Menu List .....	3-1
3.2 Test Mode Start .....	3-2
3.3 Hardware Test .....	3-2
3.4 RAM Clear .....	3-7
3.5 Printer Head .....	3-11
3.6 Label Sensor Check .....	3-13
3.7 Total Memory .....	3-14
3.8 ROM Switch .....	3-15
3.9 Peel Sensor Check.....	3-17
<b>CHAPTER 4 SETUP MODE .....</b>	<b>4-1</b>
4.1 Setup Mode Menu .....	4-1
4.2 Starting Procedure for Each Mode .....	4-2
4.3 Starting Procedure for Setup Mode .....	4-2
4.4 Label Format [Print conditions] .....	4-3
4.5 POS Code .....	4-8
4.6 Barcode [Item code] .....	4-11

4.7	Default Data .....	4-12
4.8	Total Mode Select .....	4-13
4.9	Forced Tare [USA specification only] .....	4-13
4.10	Open Price [Prohibition of Unit Price Change] .....	4-14
4.11	PLU Select [Editing PLU File].....	4-15
4.12	System [Availability of Registration Mode Menu] .....	4-22
4.13	Ethernet Setup [Ethernet Data Setting] .....	4-26
4.14	System Timer .....	4-32
4.15	Password Setup .....	4-33
 <b>CHAPTER 5 ELECTRICITY COMPOSITION .....</b>		<b>5-1</b>
 <b>CHAPTER 6 TROUBLESHOOTING .....</b>		<b>6-1</b>
6.1	Error List .....	6-1
 <b>CHAPTER 7 PARTS REPLACEMENT .....</b>		<b>7-1</b>
7.1	Detaching Each Part (Unit).....	7-1
7.2	Detaching Internal Parts .....	7-4
7.3	Periodical Replacement Parts .....	7-14
7.4	How to Pass Labels .....	7-14

# CHAPTER 1 OVERVIEW

## 1.1 Appearance and Name of Each Part

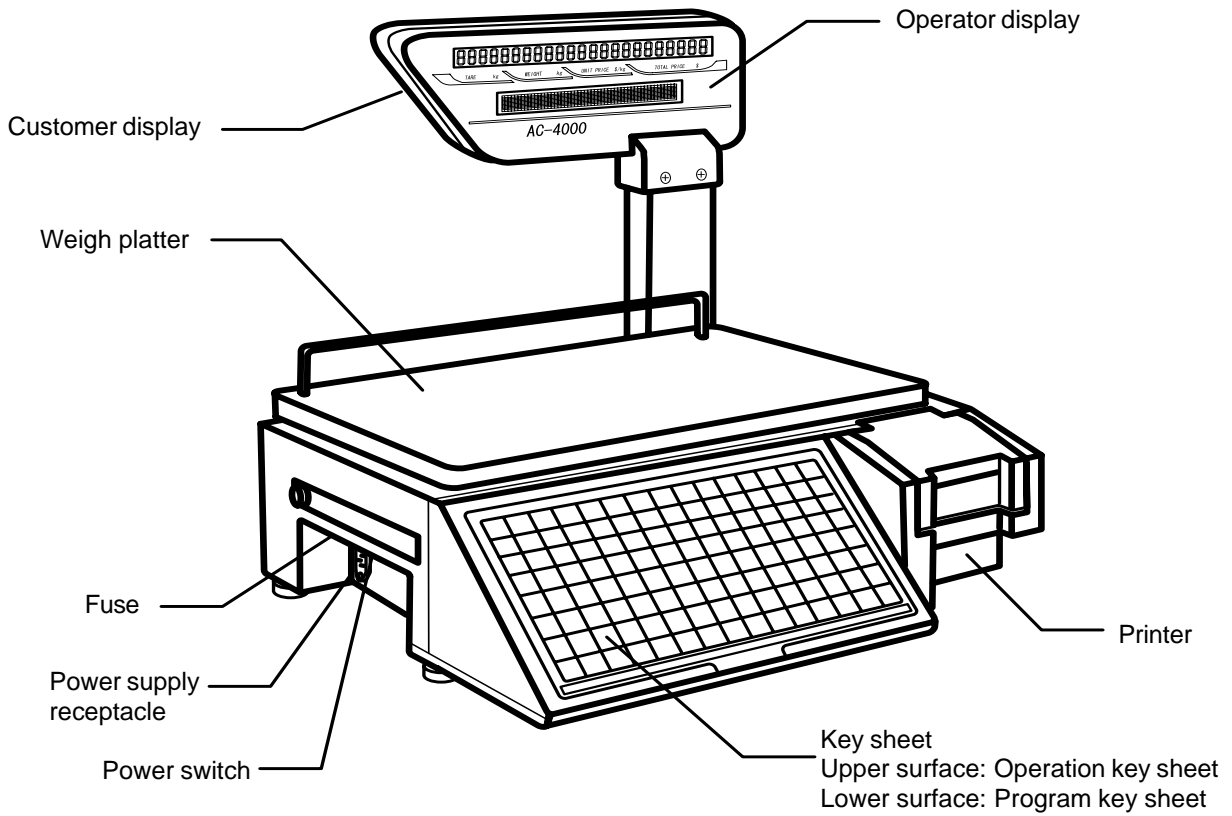

## 1.2 Display

AC-4000B

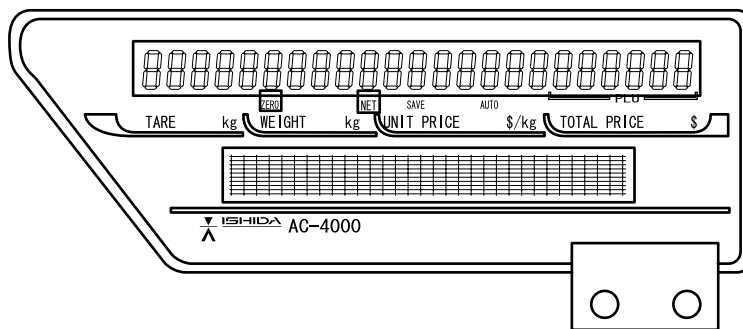

AC-4000E

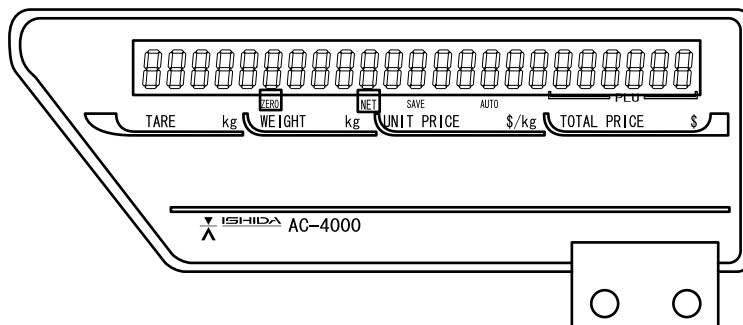



### 1.3 Key Sheet

MESSAGE			SPEED KEYS	DATE TIME	PLU LIST	STORE NAME	RECEIPT BARCODE	EDIT FUNCTIONS					ZERO			
EXTRA TEXT	COUPON TEXT	DISPLAY TEXT						BS	CHAR DELETE	←	↑	→				
REPORT NAMES			Ë	Œ	Ï	É	È	Ü	EDIT FUNCTIONS					RESET	MODE	
DEPT.	GROUP	OPERATOR						LINE DELETE	INSERT	↓	END					
								CHARACTER STYLE								
Ä	Ö	Ñ	Ç	À	Æ	Ø	β	NORMAL	ITALIC	UNDER LINE	REVERSE	BOLD	SIZE	COPY		
!	, "	#	\$	%	&	/	<	>	=	+	PRICE CHANGE	ADV PRICE	EDIT PLU	PAPER FEED		
Q	W	E	R	T	Y	U	I	O	P	?	7	8	9	●		
A	S	D	F	G	H	J	K	L	;	@	4	5	6	PRINT		
LOWER CASE	Z	X	C	V	B	N	M	,	.	●	1	2	3	PLU		
●	SHIFT	SALES		REPORTS		PRESET REPORT		●	SPACE	EDIT	*	NEW LINE	0	CLR	TARE	ENTER
	GRAND TOTAL	DAILY SALES	PRICE OVRDE													

### 1.4 Printer

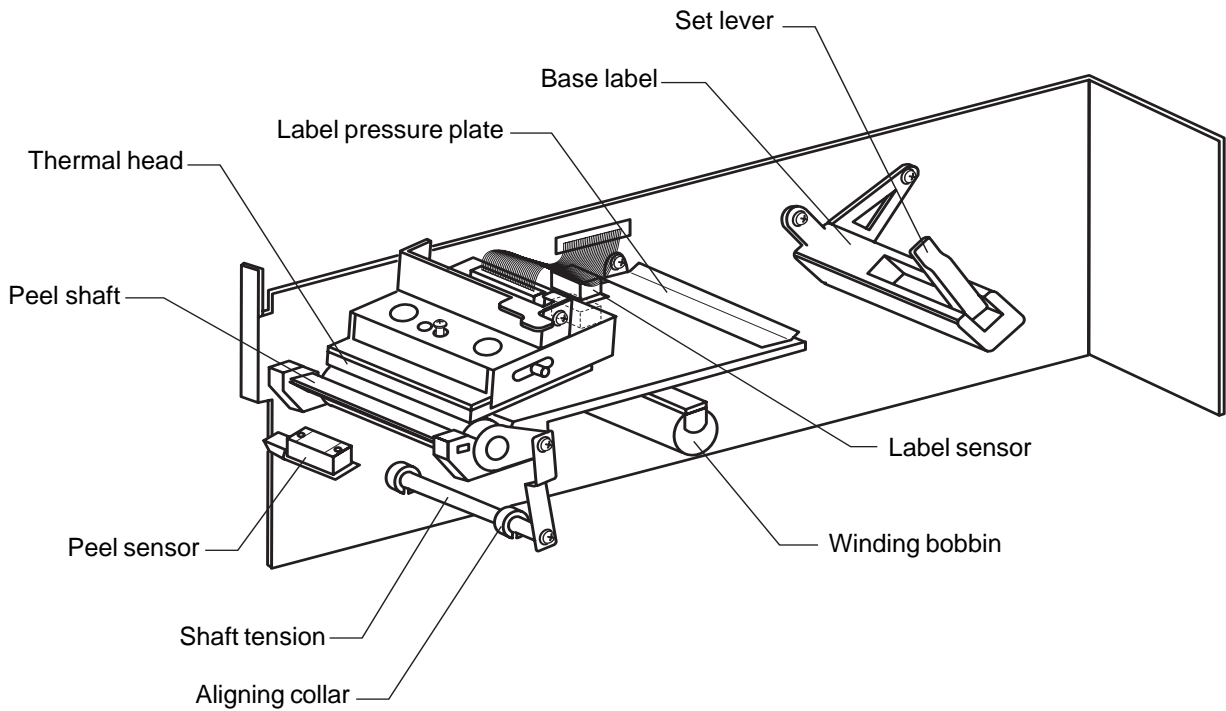

## 1.5 Main Specifications

Item	Content
Weighing capacity	15kg or 30lb
Minimum graduation	2g/5g or 0.005 lb/0.01 lb
Weighing accuracy	1/3000 (Dual-range)
Load cell	HBM made
Size of main body	450(W) x 420(D) x 440(H) mm
Weigh platter material and size	SUS430...400(W) x 250(D) mm
Printer	Backing paper width...Max. 67mm, Label width...38 to 64mm, Effective print width...Max. 60mm, Print speed...80mm/second
Label roll size	Inner diameter: 40mm, Outer diameter: 100mm
Label length	30 to 175mm
Sensor	Label sensor, Peel sensor
Key	Membrane switch (120 keys)
Display	Fluorescent display tube: 23 digits (Both for customer and operator displays) Character height: 10.1mm, 256 x 16 dots
Operating temperature	-5 to 40°C
Operating humidity	Main body: Max. 95% (40°C), No condensation Printer: Max. 80% (40°C), No condensation
Power supply	Varies depending on where the machine is used. (Specified on the rating plate)
Power consumption	Stand-by: Approx. 40W Operating: Approx. 100W
Weight	11kg
Memory capacity	Standard: 1MB Factory option: 2MB
Interface	RS232C (D-sub 9 pin)
Cash drawer	Output: DC24V/500mA
TCP/IP	10 baseT
LAN cable	Direct connection: Crossing cable When using Hub: Straight cable
SRAM	1M bytes (1,024k bytes) SRAM mapping 1. Fixed data: Approx. 19k bytes Approx. 1k bytes for fixed data year, print speed, and print density, etc., and the remainder is the reserves. 2. Logo data: Approx. 56k bytes 3. SRAM file: Approx. 949k bytes 949k bytes for registration 9k bytes for file creation (940k bytes available after RAM is cleared) PLU, Store name/address, Extra message 1/2/3, Coupon, Preset, Label format, Field title, and Operator

# 1.6 Exploded Drawing

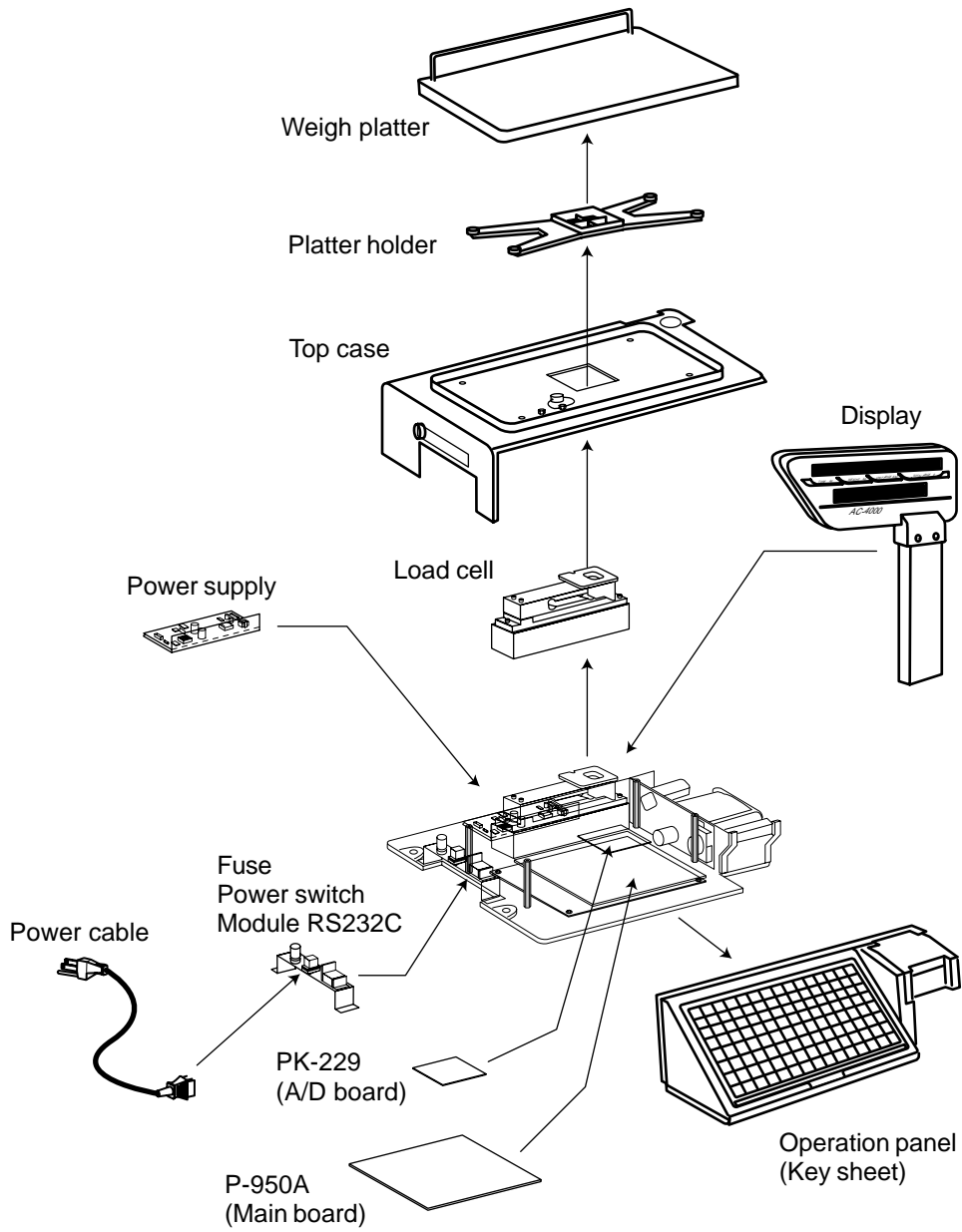

## CHAPTER 2 INSTALLATION

### 2.1 Packed Goods

Open the packing case and check whether there are all the packed goods (machine and accessories) and if there are any damaged parts.

*Note: AC-4000 "B type" or "E type" can be identified by a description of the sticker on the case.*

#### [Packed goods]

1. Stand
2. Power cable
3. Thermal head cleaner
4. Main body
5. Display
6. Weigh platter
7. Operation manual

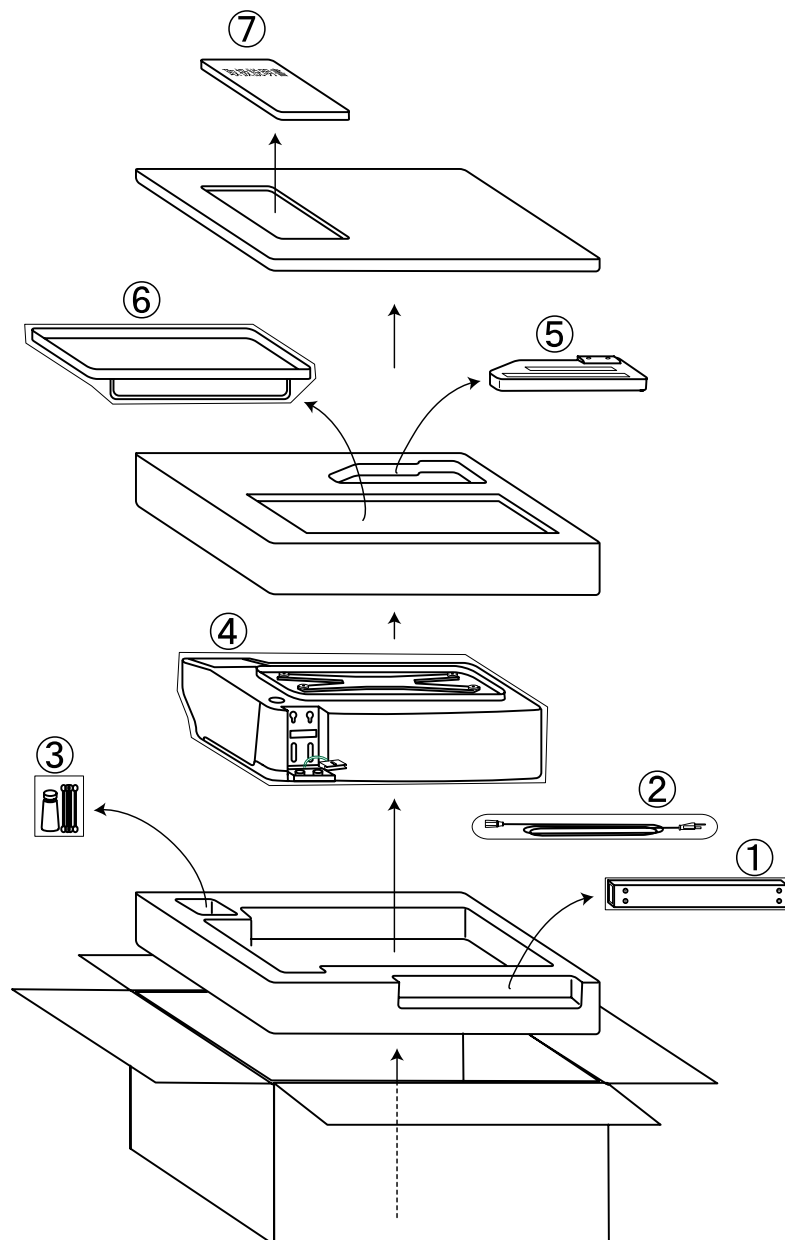

## 2.2 Installation Environment

- Install the machine on the stable and horizontal place.
- Install the machine in the place where the liquid such as water does not splash.
- Avoid the place where direct sunshine strikes for a long time.
- Install the machine in the place where the influence such as the winds is not received.
- Secure the installation space enough.

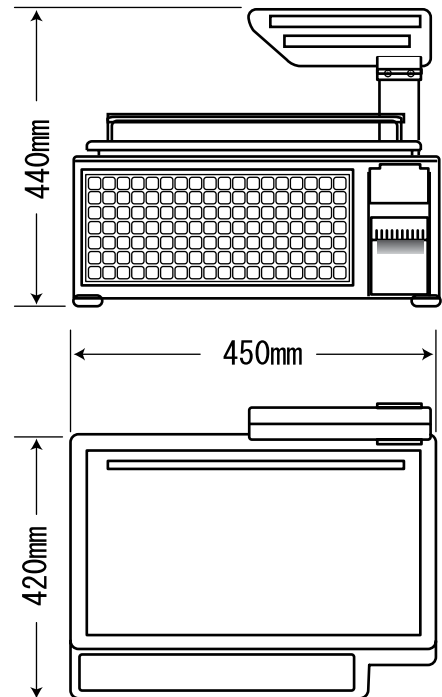

## 2.3 Assembly

1. Run the display connector (harness) through the stand, and fix the display and the stand with the 4 screws (A).
2. Engage the connector with the connector on the main body.
3. Insert the two bosses of the stand into the main body.
4. Tighten the stand and the main body with the 2 screw (B).

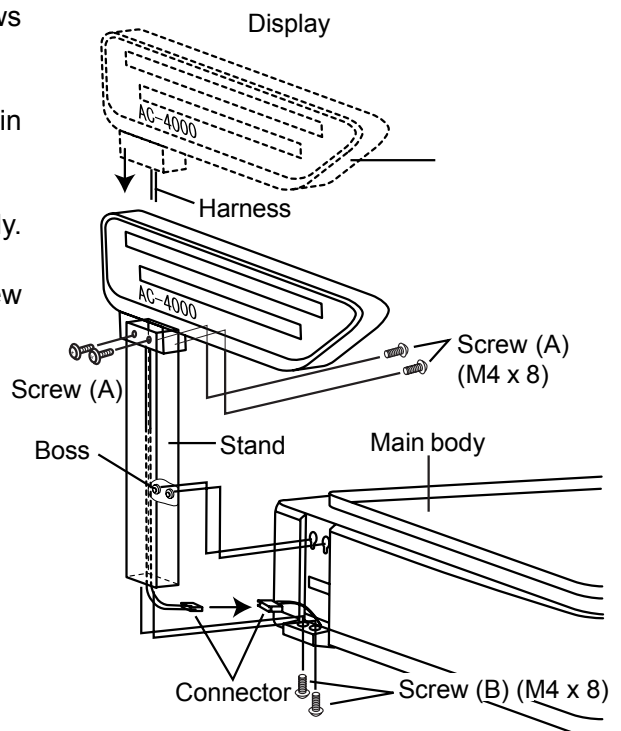

## 2.4 Weigh Platter Installation

Insert the 4 pins of the weigh platter into the rubber feet on the platter holder.

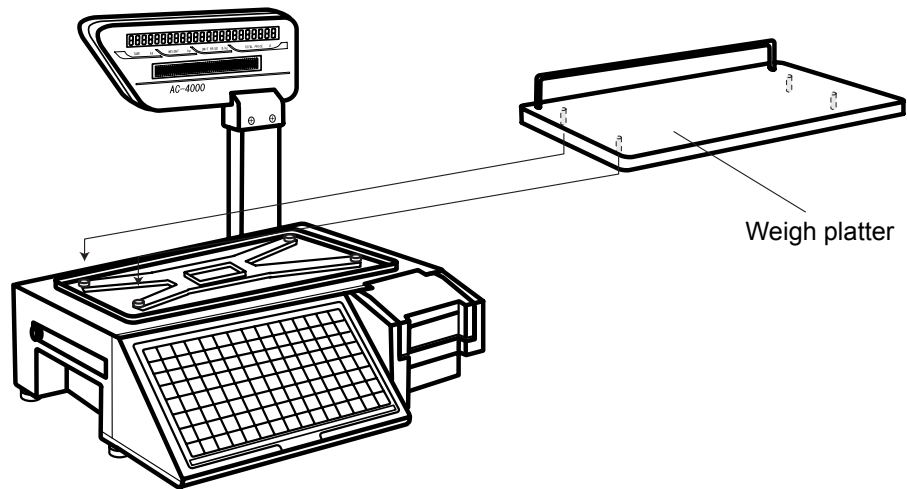

## 2.5 Label Loading

- Open the side cover of the main body.
- Load the label roll as shown in “How to pass labels”.

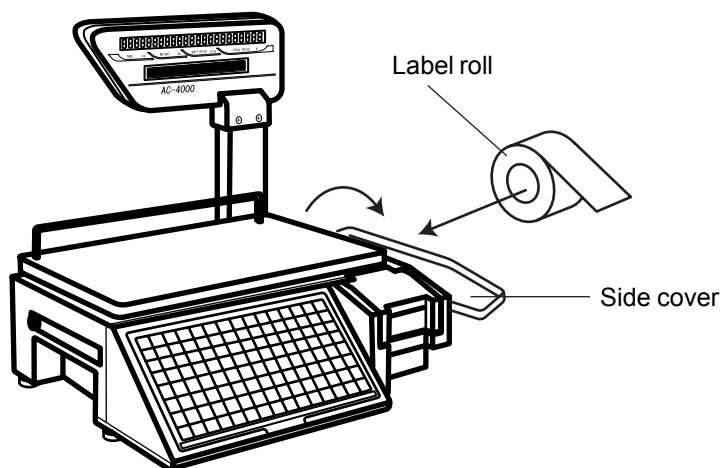

### How to pass labels

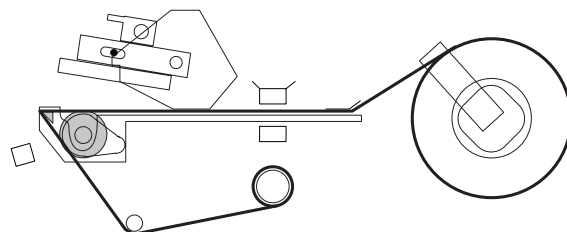

## 2.6 Power Cable Connection

- Insert the power cable into the receptacle at the left of the main body.
- Insert the power cable plug into the power outlet.

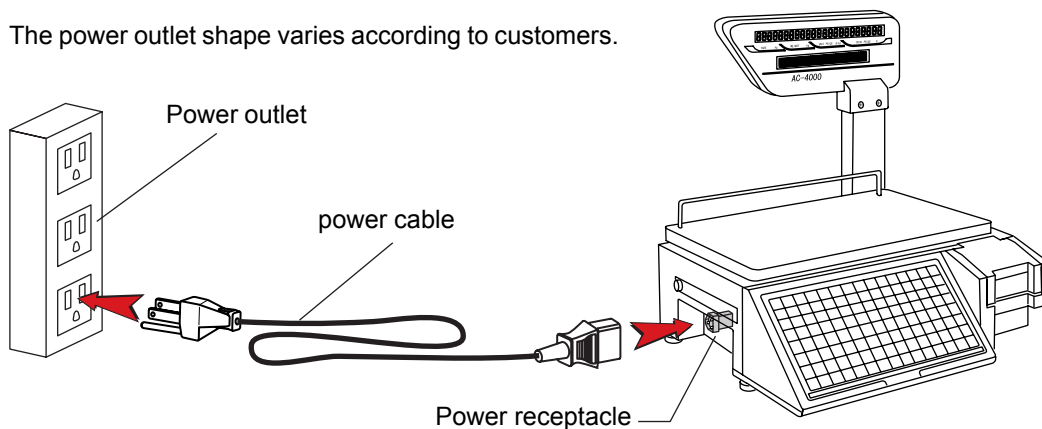

**CAUTION** Ensure to establish a ground at the customer side. 110 V /220 V input power supply can be used. However, set the jumper lead to the required voltage display side before the power is turned ON.

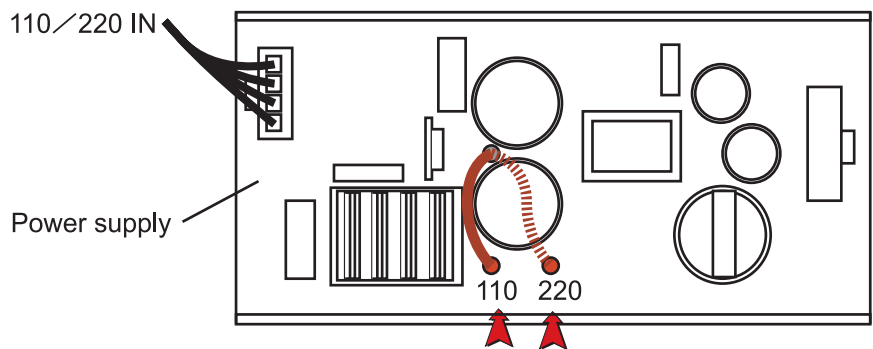

## 2.7 Power Switch “ON”

- Turn on the power switch located at the left side of main body.

*Note: Push the “O” side of the switch to urn off the power.*

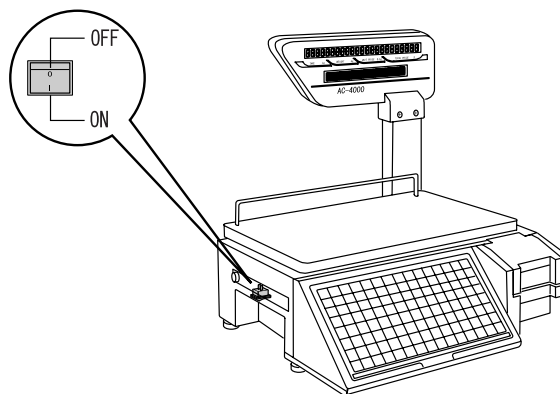

## 2.8 Customer's Specification Setup (Initialization, Setup, and Registration)

Set up required specifications according to the following sequence.

### Test mode (Refer to Chapter 3 "Test Mode")

1. Hardware test.....	P.3-2
2. RAM clear .....	P.3-7
3. Printer head.....	P.3-11
4. Label sensor check .....	P.3-13
5. Total memory .....	P.3-14
6. ROM switch .....	P.3-15
7. Peel sensor check.....	P.3-17

### Setup mode (Refer to Chapter 4 "Setup Mode")

1. Label format .....	P.4-3
2. POS code .....	P.4-8
3. Barcode .....	P.4-11
4. Default data .....	P.4-12
5. Total mode select .....	P.4-13
6. Forced tare .....	P.4-13
7. Open price .....	P.4-14
8. PLU selection .....	P.4-15
9. System .....	P.4-22
10. Ethernet setup .....	P.4-26
11. System timer .....	P.4-32
12. Password setup .....	P.4-33



## 2.9 Normal Mode Display

1. All segments blink three times when the power is turned on.

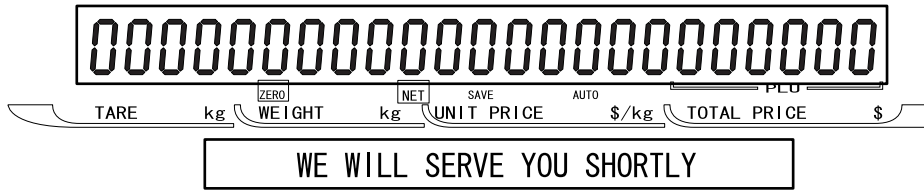

2. Then, the initial display appears.

■Operator display

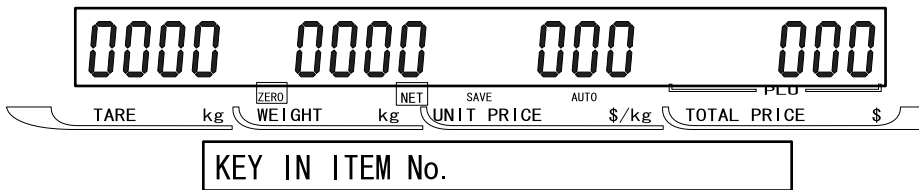

■Customer display

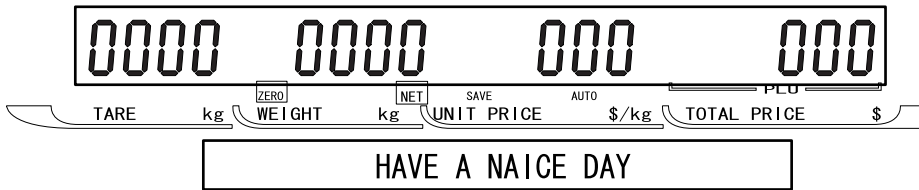

3. When calling up "Fixed price item" or "Weighing item".

■Weighing item

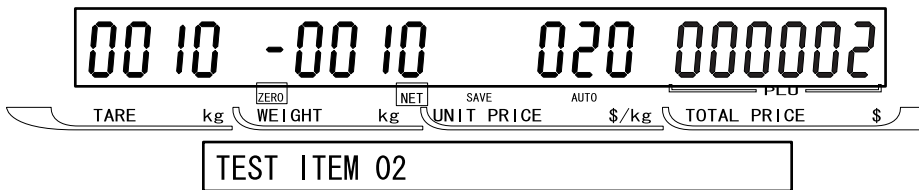

■Fixed price item

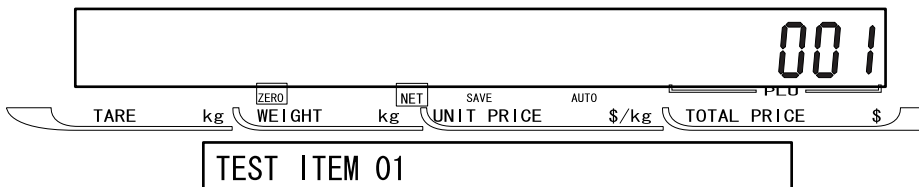

## 2.10 Label Batch Print Mode

- The following display appears when printing batches of labels.
- The label batch printing is a function which prints the item data and the number of labels registered in advance a for fixed price items.

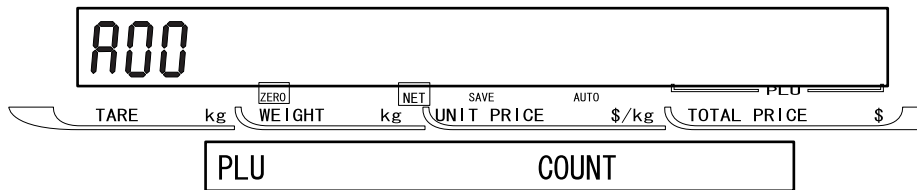

- Maximum number of specified items: 99 commodities
- Maximum number of specified labels: 9,999 labels
- Preset key number: 19 presets

*Note: Registered data is cleared when the power is turned OFF.*

### 2.10.1 Basic operation

- Assign the BATCH PRINT key (Preset key number: 19) to any one of preset keys. P04-01-01 screen menu ..... 19 + FEED + 0 + Preset key



- Press the LABEL BATCH key to enter the label batch print mode. This function is available before an item is called up.
  1. Call up a fixed price item.  
Key in an item number, then press the PLU key.  
*Note: An error buzzer sounds when other item is called than fixed price item.*
  2. Specify the number of labels to be printed.  
Key in the number of labels, then press the ENTER key.  
*Note: An error buzzer sounds when the limited number of labels (9,999 labels) exceeds.*
  3. Repeat above steps 1. and 2. to specify the number of labels for other items.  
*Note: An error buzzer sounds when exceeding the maximum number of specified items (99 items).*
  4. Press the PRINT key to start printing. Then, printing starts in the sequence from the most recently registered item.  
*Note: An error buzzer sounds when there is no item registered for label batch printing.*
  5. The machine returns to the normal mode after all registered items are printed.

### 2.10.2 Additional functions

1. End of the label batch print mode  
The machine returns to the normal mode when the MODE key is pressed.  
The registered data is preserved as it is if there are any registered items.
2. Printing preserved data  
If there is any preserved print data, printing starts by pressing the PRINT key.  
*Note: An error buzzer sounds if there is no registered data.*

**3.** Deleting label batch print data

The label batch print data is deleted while sounding an OK buzzer by pressing the ZERO key twice.

**4.** Stop of label batch print operation

Label batch print stops by pressing the PRINT key while printing a print reservation data.

However, the remaining label batch print items are not deleted.

(If printing stops when five labels have been issued for an item specified to issue 10 labels, the remaining 5 labels are preserved.)

**5.** Addition of label batch print data to the preserved data

The label batch print data is added to the preserved data.

(When there are "40 preserved items", "59 items" can be added.)

**2.10.3 Label batch printing on continuous paper**

The same operation is applied for continuous paper which is set in the B01-01-05 menu.

Refer to 4-4 in Chapter 4.

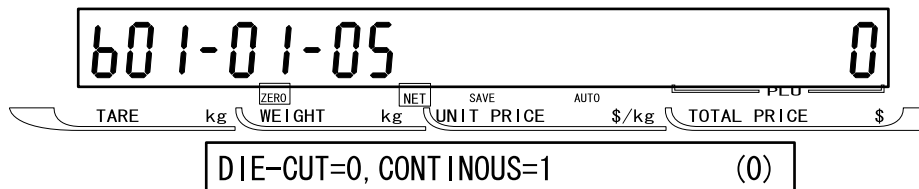

## 2.11 Scroll Message Display

- A function to display the registered scroll message. When an item has not been called up, it starts after five seconds have passed.

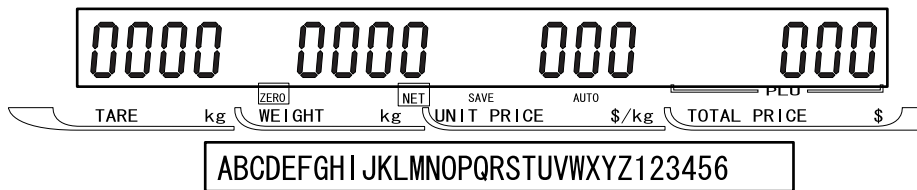

- Display method registration function  
(0: No display 1: High-speed scroll 2: Normal scroll 3: Low-speed scroll 4: High-speed blinking 5: Normal blinking 6: Low-speed blinking)
- Day of the week registration function  
(0: Every day 1: Sunday 2: Monday 3: Tuesday 4: Wednesday 5: Thursday 6: Friday 7: Saturday)
- Display time registration function (Start/stop)

**[Example]** 09:00 to 13:00  
Enter "0913" and press the ENTER key.

- Maximum number of scroll messages: 9 messages (1 to 9)
- Maximum number of characters: 96 characters (one byte English code)

## 2.12 Campaign Function

- Registered campaign items start to be sold at the registered campaign price when the time reaches registered campaign time.

- Maximum number of campaign: 20
- Maximum number of items for each campaign: 100
- Discount method  
(0: Unit price 1: Special price 2: Amount discount 3: Percent discount 4: Special unit price)

- Campaign 1 becomes top priority for items registered during the overlapping time.
- Priority is given from Campaign 1, 2, and 3 to the last 20 if the same item is registered. That is, priority is given to the campaign 1 even if the same item is registered in campaign 1 and 2 during the overlapping time.
- Registration of the same item is not supported in one campaign.
- An error message appears when a label is issued with a registered price in the campaign greater than the weighing price.

# CHAPTER 3 TEST MODE

## 3.1 Test Mode Menu List

### ■Hardware test

_____	a) A/D check .....	P. 3-3
_____	b) Key check .....	P. 3-4
_____	c) Display check .....	P. 3-4
_____	d) RS232C check .....	P. 3-5
_____	e) Application program number .....	P. 3-5
_____	f) BIOS program number .....	P. 3-6

### ■RAM clear

_____	a) RAM clear .....	P. 3-7
_____	b) Setup clear .....	P. 3-8
_____	c) Test data set .....	P. 3-8
_____	d) Application copy .....	P. 3-9
_____	e) BIOS copy .....	P. 3-9

### ■Printer head

_____	a) Resistance .....	P. 3-11
_____	b) Print usage in km .....	P. 3-12
_____	c) Resistance value .....	P. 3-12

### ■Label sensor check

_____	• Level sensor .....	P. 3-13
-------	----------------------	---------

### ■Total memory

_____	• Memory .....	P. 3-14
-------	----------------	---------

### ■ROM switch

_____	• ROM switch number .....	P. 3-15
-------	---------------------------	---------

### ■Peel sensor check

_____	• Peel sensor .....	P. 3-17
-------	---------------------	---------

### 3.2 Test Mode Start

Reset the main power or press the RESET key, then immediately press and keep pressing any key other than the RESET key for a while until a buzzer sounds, the following test mode menu screen will appear by releasing the key.

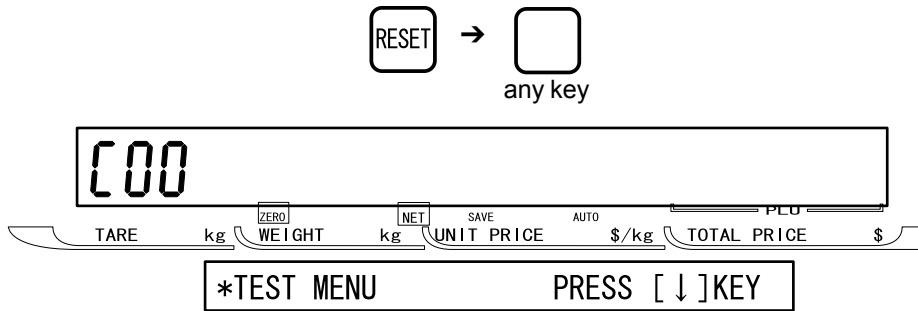

### 3.3 Hardware Test

#### ■Hardware test mode selection screen

To select a desired menu, press the key to increment a menu, or enter a menu number followed by pressing the [↓] key.

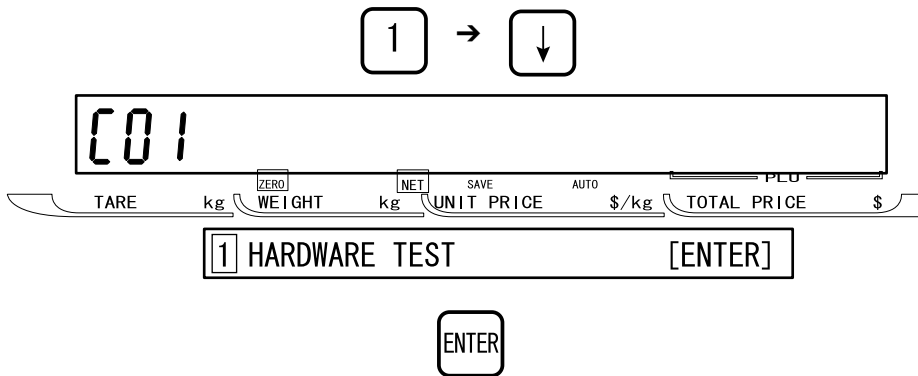

### ■A/D CHECK [Scale zero point/span check and adjustment]

- In the [C01] display, press the ENTER key to select the A/D CHECK menu. (It will take a few seconds until the A/D board is initialized.)

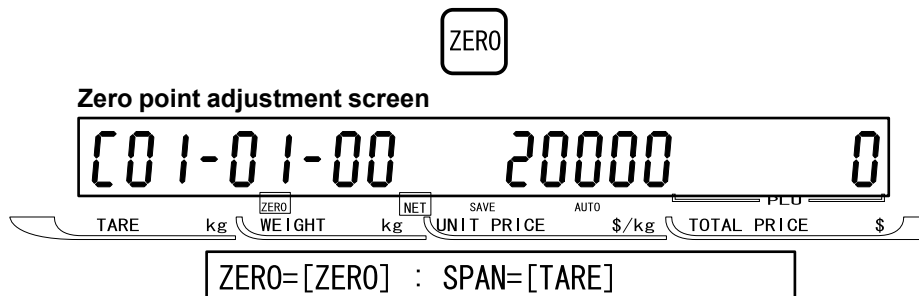
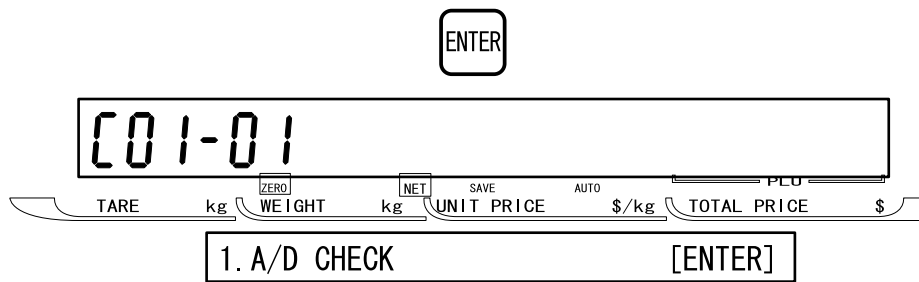

- Firstly, the A/D original data appears.
- Pressing the ZERO key changes to the calibrated data of "20000" counts and "0". ("20000" counts is a data output from the A/D unit, and "0" denotes that "20000" counts are regarded as zero point.)
- In "C01-01-00" menu and after a zero point adjustment, put the same weight as the maximum weighing capacity and press the TARE key to perform an auto-span.

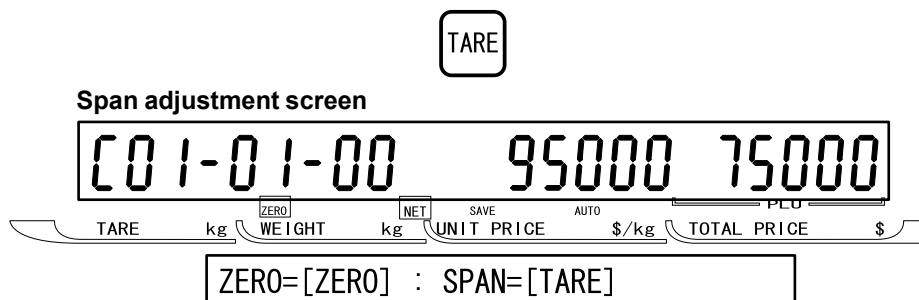

- After the span adjustment, finish to check the zero point and the weighing capacity value by repeating zero point and span adjustments.
- After completing the span adjustment, push the memory button on the board to store the adjustment value in E2ROM.
- When initializing E2ROM of the A/D circuit to the initial value, press the DEL key to initialize.
- When E2ROM storage completes, press the END key to return to the hardware test menu screen.

*Note 1: Changed data is cleared at the end of this menu unless it is stored in E2ROM by pushing the memory button.*

*Note 2: The memory button is described in "Chapter 5".*

■KEY CHECK [Membrane key check mode]

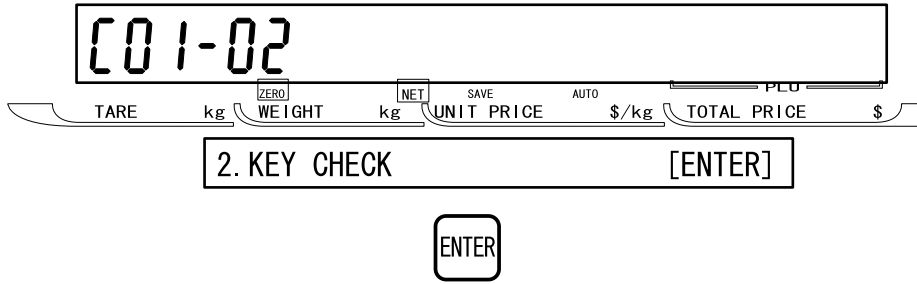

- The input membrane key data other than the RESET key is displayed.

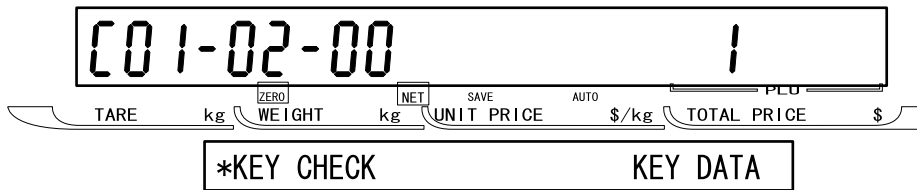

- Press the RESET key to return to the hardware test menu screen.

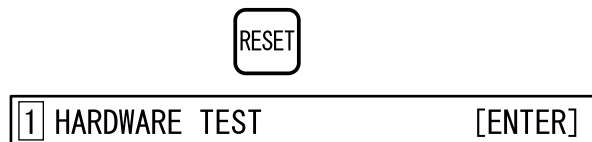

■DISPLAY CHECK [Multiple tube display check mode]

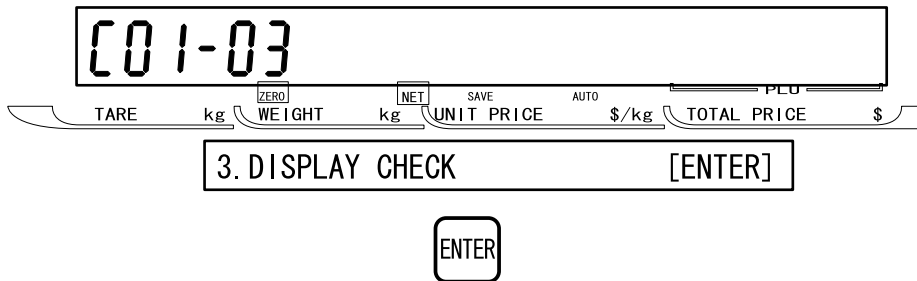

- Each segment of all digits lights up.  
(This display flashes in one second interval.)

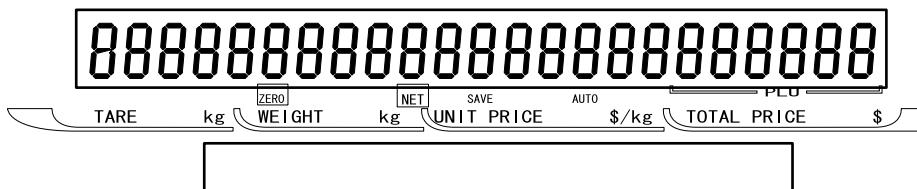

- Press the END key to return to the hardware test menu screen.

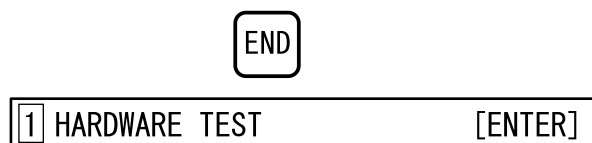



### ■RS232C CHECK [Driver/receiver test]

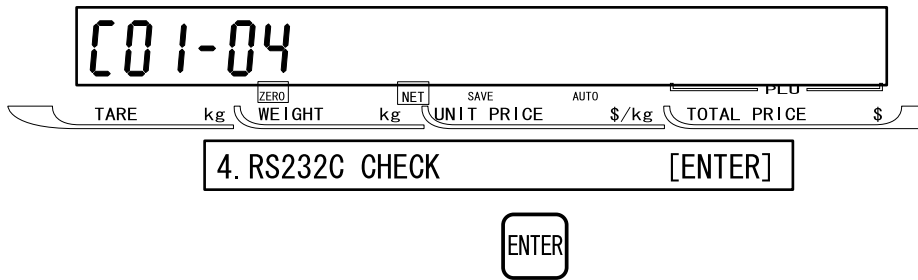

- Serial output port (RS232C) driver/receiver test menu screen

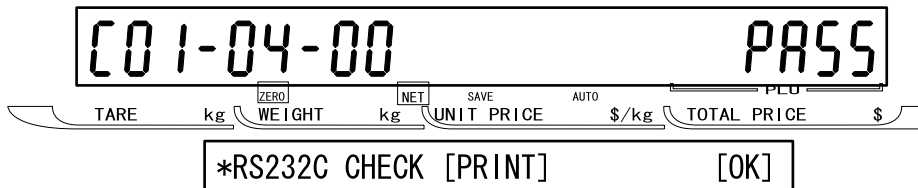

- Perform a loop back test to carry out the RS232C input test. Engage the TXD and RXD short-circuited connector with D-SUB 9, press the PRINT key to output test data, and judge by verifying received test data and sent data.  
If the data matches, "PASS" is displayed and "OK" buzzer sounds.  
"ERR" is displayed and "NG" (No Good) buzzer sounds.
- Press the RESET key to return to the hardware test menu screen.

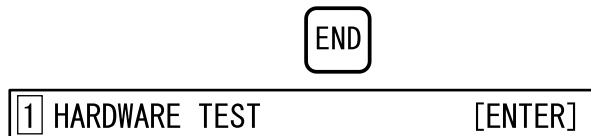

### ■APPLICATION PROGRAM No. [Program no. and version display check]

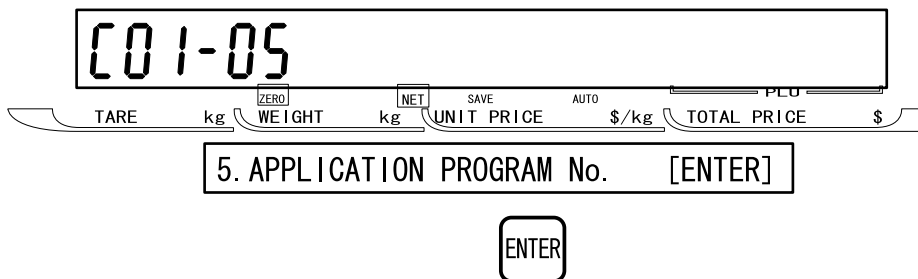

- The program number and version of the main program are displayed.  
*Note: The program number for the prototype is the development code "APPLY".*

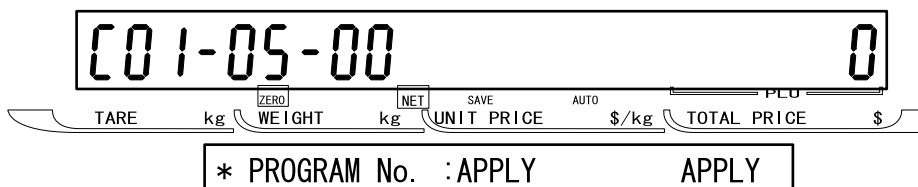

- Press the END key to return to the hardware test menu screen.



■ BIOS PROGRAM No. [Program no. and version display check]

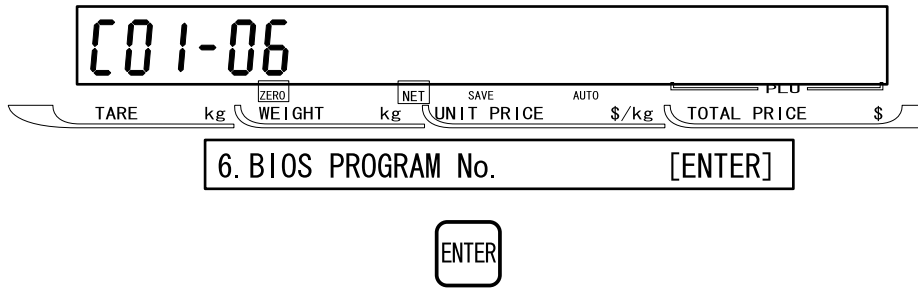

- Program number and version of the BIOS program are displayed.

*Note: The program number for the prototype is the development code "BOOT".*

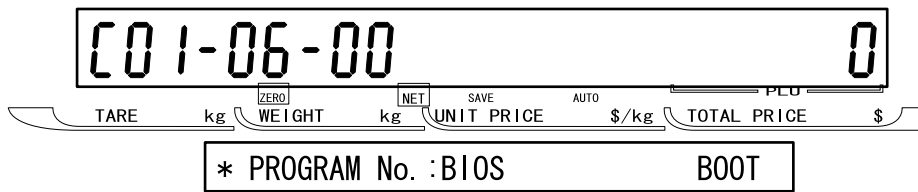

- Press the END key to return to the hardware test menu screen.

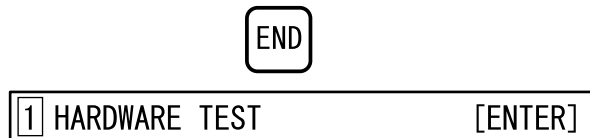

## 3.4 RAM Clear

### ■RAM clear test mode selection screen

Press the [↓] key to increment a menu, or enter a menu number followed by pressing the [↓] key.

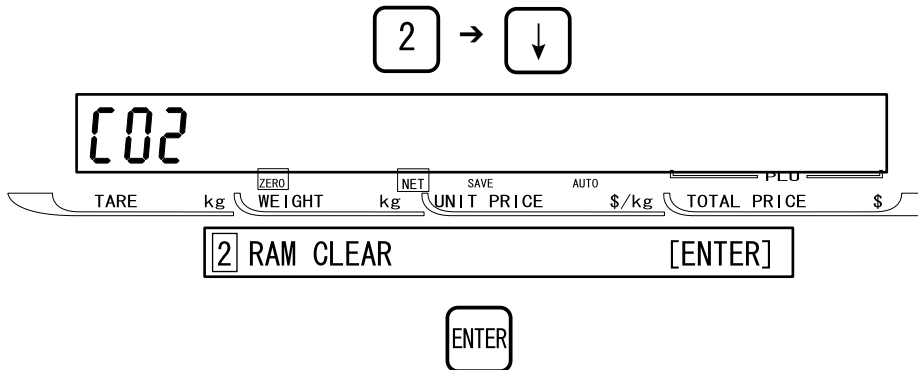

### ■SRAM CLEAR

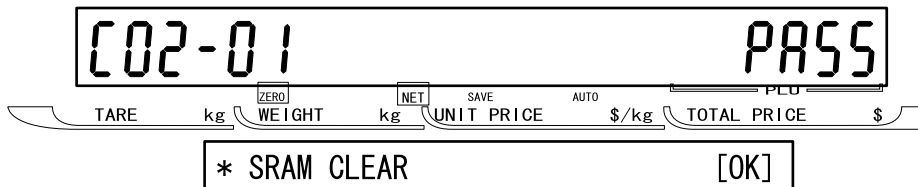

- This menu is used when clearing SRAM. When this menu is executed, all the SRAM data is cleared (initialization). SRAM clear is executed by pressing the ZERO key twice.

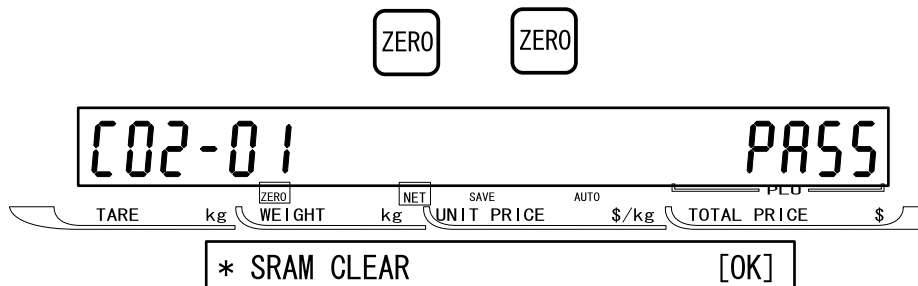

- When SRAM clear is complete, "PASS" is displayed and "OK" buzzer sounds.
- If an error is detected, "ERR" is displayed and "NG" (No Good) buzzer sounds.

■SETUP CLEAR [E2ROM default]

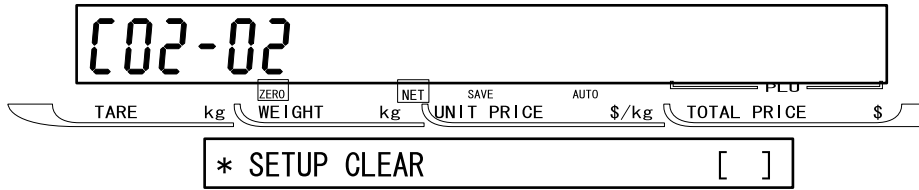

- This menu is used when initializing E2ROM to a default value. When this mode is executed, the content of the E2ROM switch is initialized to default. SRAM clear is executed by pressing the ZERO key twice.

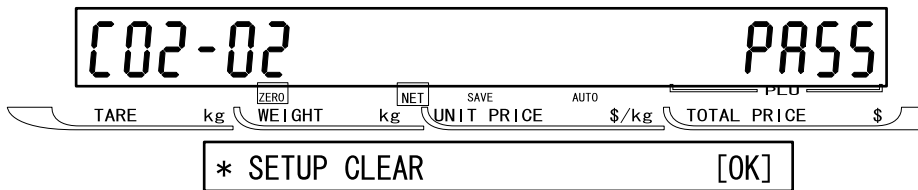

- When processing is complete, "PASS" is displayed and "OK" buzzer sounds.
- If an error is detected, "ERR" is displayed and "NG" (No Good) buzzer sounds.
- Press the END key to return to the hardware test menu screen.



■TEST DATA SET [Test data is set]

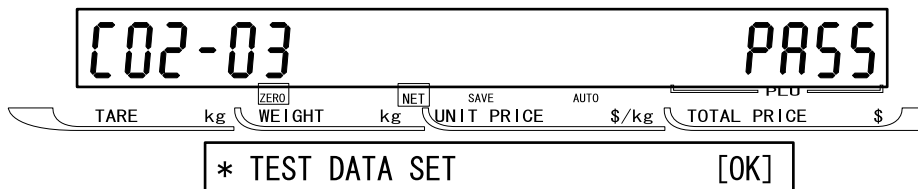

- This menu is used when setting up the machine for the first time (when there is no backup data).
- In this mode, execute a set of SRAM clear + E2ROM setup + Dummy data creation.
- The dummy data memorizes 10 PLU data and the store name/address.
- SRAM clear is executed by pressing the ZERO key twice.

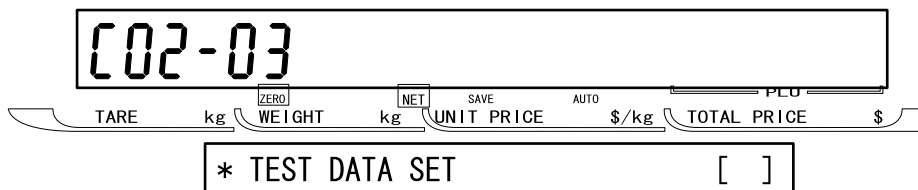

- When processing is complete, "PASS" is displayed and "OK" buzzer sounds.
- When an error is detected, "ERR" is displayed and "NG" (No Good) buzzer sounds.

- Press the END key to return to the hardware test menu screen.

END

[1] HARDWARE TEST	[ENTER]
-------------------	---------

### ■APPLICATION COPY [Writing application]

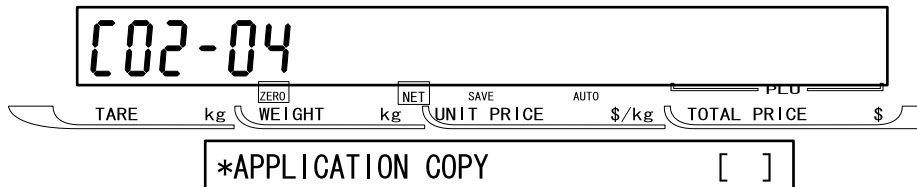

- Write the application part of flash ROM. [1M byte]

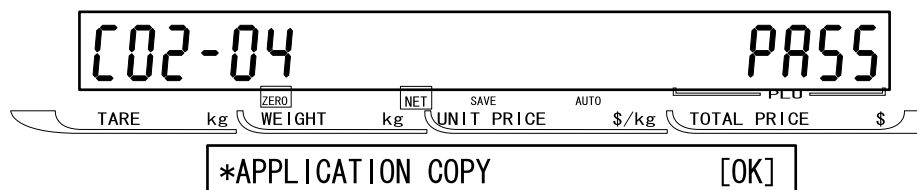

- When processing is complete, "PASS" is displayed and "OK" buzzer sounds.
- When an error is detected, "ERR" is displayed and "NG" (No Good) buzzer sounds.

### ■BIOS COPY [Writing boot program]

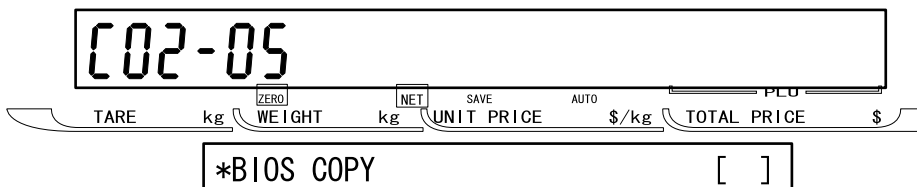

- Write the boot program part of flash ROM. [512k byte]

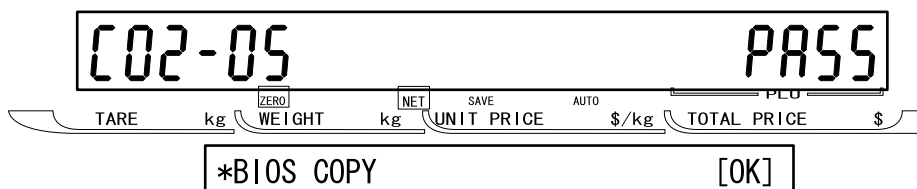

- When processing is complete, "PASS" is displayed and "OK" buzzer sounds.
- When an error is detected, "ERR" is displayed and "NG" (No Good) buzzer sounds.



BIOS COPY is not displayed in test mode.

### ■When using BIOS COPY

- If the machine locks, or the test mode entry is not possible, enter [APPLY COPY] → [BIOS COPY] and a transmission end message appears in [BIOS COPY], then press the ZERO key twice. [EXEC] + [PASS] is displayed.
- Standing up state after BIOS COPY is operated.
  - Internet Protocol address: 192. 168. 10. 1
  - Log-in: TEST
  - Password: USNET
- Perform “APPLI COPY” in the same operation as the above-mentioned.

### ■BOOT COPY starting procedure

1. Turn on the power switch while pushing the Memory button.

*Note 1: Remove the plastic cap on the upper part of the top cover. Then, the Memory button can be seen right under the cap.*

*2: Press the [↵] key. Then, “BOOT COPY” is displayed.*

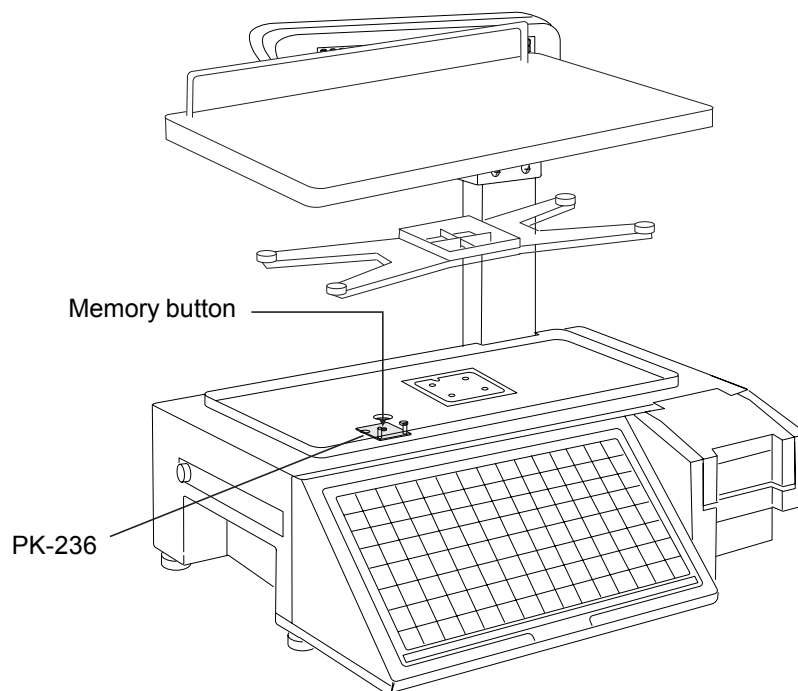

## 3.5 Printer Head

### ■Printer head test mode selection screen

Press the [↓] key to increment a menu, or enter a desired menu number followed by the [↓] key.

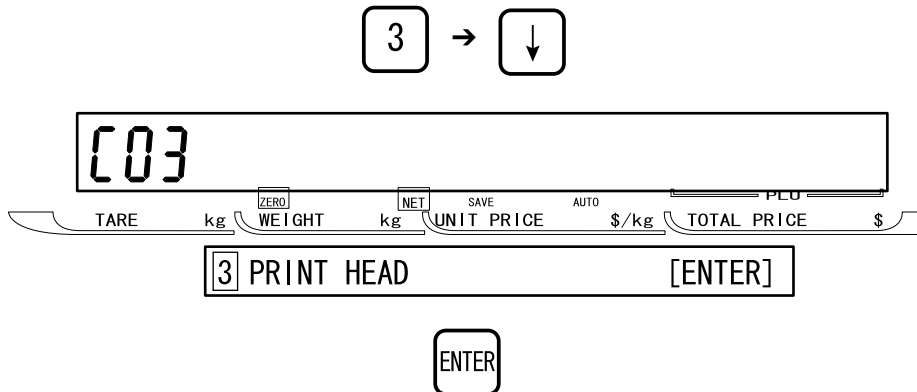

### ■RESISTANCE [Setting thermal head resistance value]

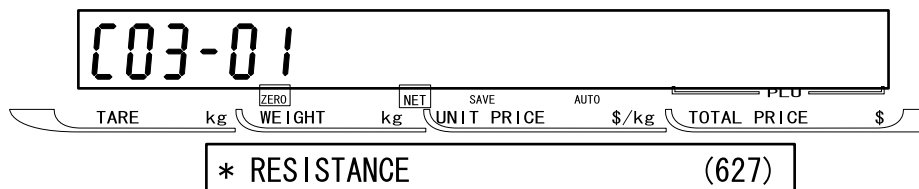

- Set a resistance value of the thermal head.
- Press the COPY key to read ID from the thermal head and set it automatically.



Or, enter a resistance value described on the head followed by the ENTER key.



- Stored data is memorized in E2ROM.

■PRINT USAGE IN km [Label travel distance display and clear]

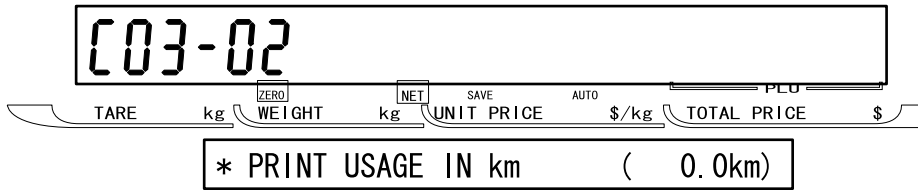

- This menu is used to check the print total travel distance. It is memorized in 100m unit (0.1km) and displayed.
- When resetting the travel distance:  
Enter the password "495344", and press the SIZE key.



■RESISTANCE VALUE \*ADJUSTMENT [Print density adjustment]

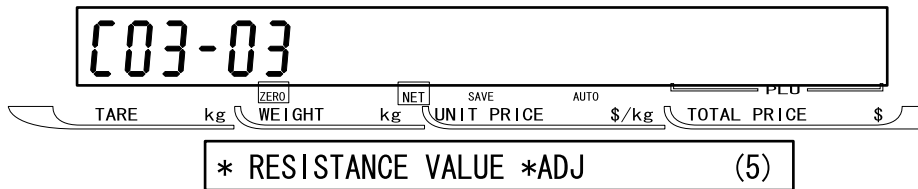

- Adjust the thermal head print density.
- Print density adjustment range: 1 (Thin) to 9 (Thick) [Default value = 5]
- Press the END key to return to the test mode menu screen.

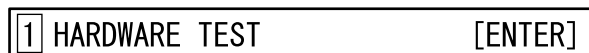



## 3.6 Label Sensor Check

### ■Label sensor check test mode selection screen

Press the [↓] key to increment a menu, or enter a desired menu number followed by the [↓] key.

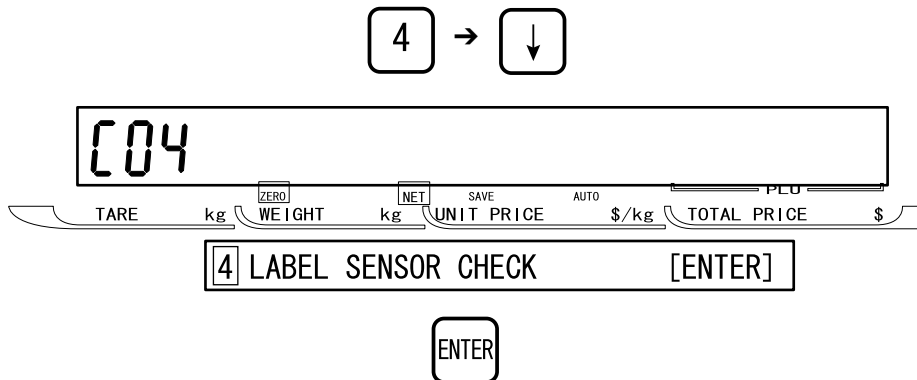

### ■LABEL SENSOR [Label sensor output value adjustment]

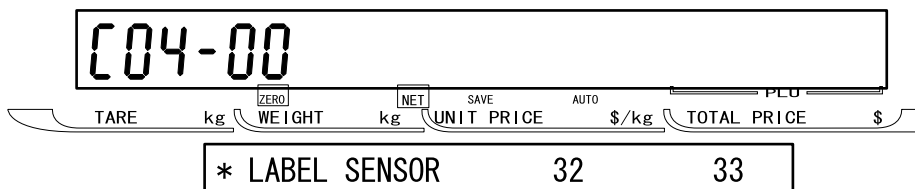

- [32 ]: Label sensor resistance value
- [33 ]: Label sensor output value (Label + Baking paper)
- [140]: Label sensor output value (Baking paper only)
- At adjustment: Label sensor output value deviation must be 50 or more between the case when a label exists and when no label exists.
- Output from the label sensor is displayed with a value after passing through the A/D converter.
- Adjustment value range: 0 to 255
- Adjustment method: Adjust the label sensor volume in digital form. Key in "0 to 255" and press the ENTER key to store.
- Press the END key, then the MODE key to return to the test mode menu screen.

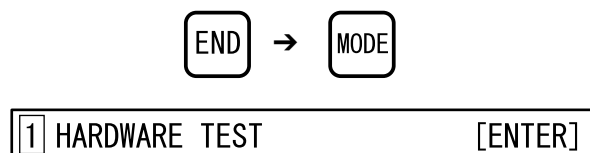

### 3.7 Total Memory

**■Total memory test mode selection screen**

Press the [↓] key to increment a menu, or enter a desired menu number followed by the [↓] key.

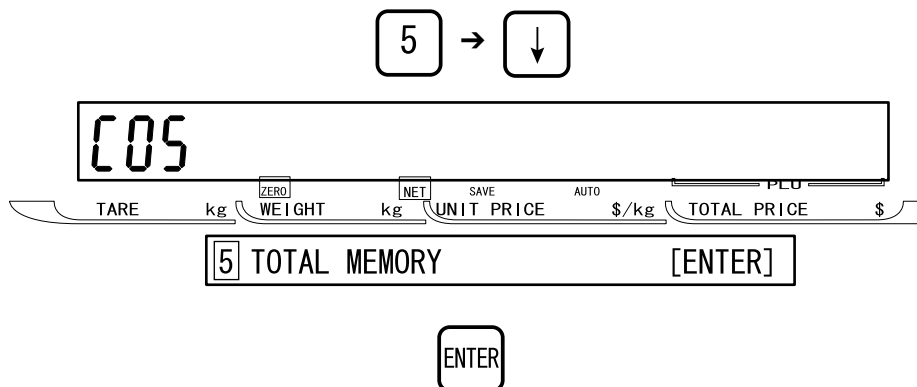

**■MEMORY [Memory usage status is checked]**

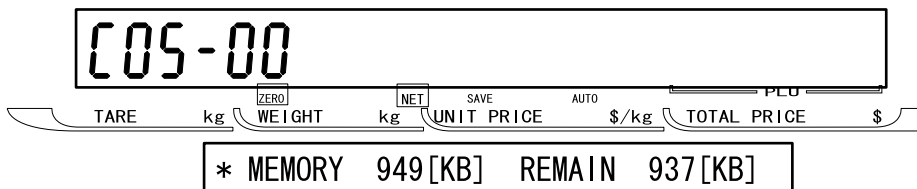

- A total memory and a free memory are displayed.
- A free memory is not necessarily corresponding to the remaining amount which can be stored, because it indicates only the one that the block is completely free.
- Press the END key to return to the test mode menu screen.

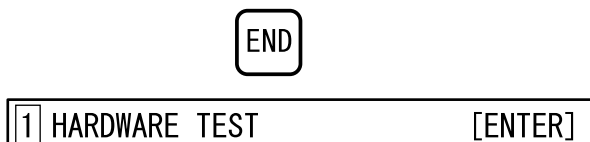

## 3.8 ROM Switch

### ■ROM switch test mode selection screen

Press the [↓] key to increment a menu, or enter a desired menu number followed by the [↓] key.

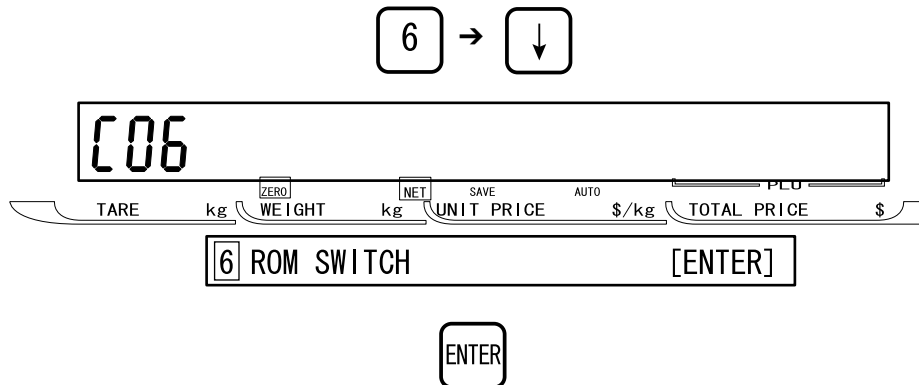

### ■ROM SWITCH No. SELECT [E2ROM switch change and check]

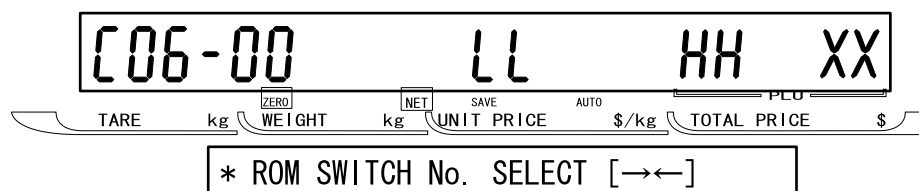

- Change or check the E2ROM switch in this menu.
- Multiple tube display "LL", "HH", "XX"  
 "LL" indicates the E2ROM address.  
 "HH" indicates the E2ROM address data.  
 "XX" monitors the input data.
- To specify an address, enter the address (ROM switch no.) and press the [↓] key to select.
- To change a data, enter hexadecimal numerics by using the alphabet of [A to F] and numerics of [0 to 9].
- Press the END key to return to the test mode menu screen.

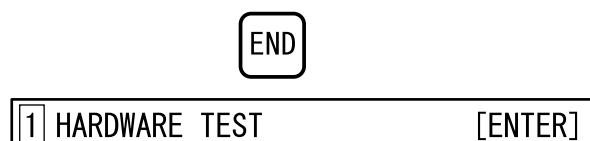

## ■ROM SWITCH No.

Note: "ROM SWITCH" items and default value vary depending on a country where the machine is used.

- Value in ( ) indicates the default value.

[0]: Weight data zero suppression (4)

[1]: Price data zero suppression (3)

[2]: Unit price data zero suppression (3)

[3]: DC motor (41)

[4]: Fixed price item quantity addition "0": Real number "1": Fixed price item quantity

[5]: Price calculation rate "0": kg "1": 100g

[7]: Effective day calculation

When ROM SWITCH No.7 is "0", packed date is included. When ROM SWITCH No.7 is other numeric than "0", packed date is not included, therefore, add one day to the current effective day.

[8]: Time rounding calculation 0, 1 to 30 (0)

Function to increase the price based on the set minute at time now is set by standard.  
(Minute/No. 8) \* No. 8

[Example]

◇ Example: No. 8 = 1 min.

1 → 1 min., 2 → 2 min., ..... 59 → 59 min.

◇ Example: No. 8 = 2 min.

1 → 0 min., 2 → 2 min., 3 → 2 min., 4 → 4 min., 5 → 4 min., ..... 58 → 58 min., 59 → 58 min.

◇ Example: No. 8 = 3 min.

1 → 0 min., 2 → 0 min., 3 → 3 min., 4 → 3 min., 5 → 3 min., 6 → 6 min., ..... 57 → 57 min.  
58 → 57 min., 59 → 57 min.

⋮

◇ Example: No. 8 = 30 min.

1 → 0 min., 2 → 0 min., 3 → 0 min., 4 → 0 min., 5 → 0 min., 6 → 0 min.  
29 → 0 min., ..... 30 → 30 min., 31 → 30 min., ..... 59 → 30 min.

[9]: Subtotal label item name mode

0 : "sub total" is printed.

1: Item name is printed when an item is called.

[10]: Reset key 0: Enable 1: Disable (0)

[11]: Automatic clear after totals are sent out

0: Not cleared (default) 1: Clear

[15]: Price calculation fraction processing (0)

0: 3rd decimal digit round-down 1: 3rd decimal digit round off

2: 2nd decimal digit round-down 3: 2nd decimal digit round off

[16] ITF BARCODE check digit calculation processing (0)

0: 3131. . . . . from the right 1: 1313. . . . . from the right

[17]: Head fault check (0)

0: Not available 1: Available (Set "0" for ASTRA XT)

[18]: Head fault check timing (0)

0: When calling 1: When issuing (no provision) ff: Only when changing to normal mode

[19]: Head check type (0)

0: Always at the head fault 1: When the number of head fault increases.

### 3.9 Peel Sensor Check

#### ■PEEL SENSOR output value test mode selection screen

Press the [↓] key to increment a menu, or enter a desired menu number followed by the [↓] key.

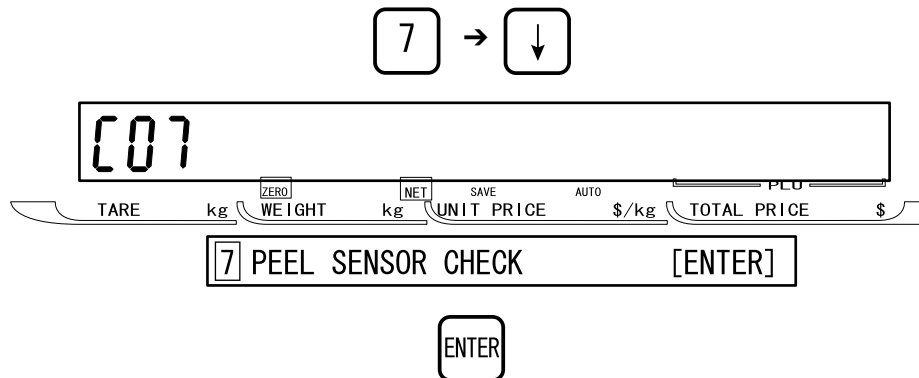

#### ■PEEL SENSOR [Peel sensor output value is checked.]

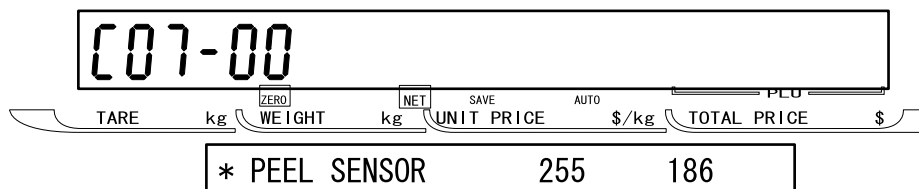

- Sensor value display  
 [255]: Peel sensor resistance    [186]: Peel sensor output value (Label + Backing paper)  
 [255]: Peel sensor resistance    [0]: Peel sensor output value (Backing paper only)
- Output from the peel sensor is displayed with a value after passing through the A/D converter.
- Setting range: 0 to 255
- Input method: Key in 0 to 255, and press the ENTER key to store.
- Press the END key to return to the test mode menu screen.

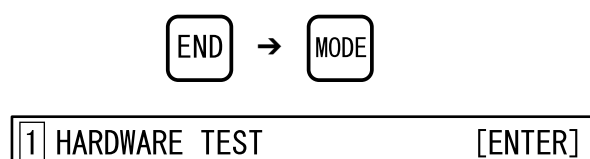

# CHAPTER 4 SETUP MODE

## 4.1 Setup Mode Menu

### ■ Setup menu list

- Labels

- |                    |  |   |
|--------------------|--|---|
| a) Print condition | <ul style="list-style-type: none"> <li>_____</li> <li>_____</li> <li>_____</li> <li>_____</li> <li>_____</li> <li>_____</li> <li>_____</li> <li>_____</li> <li>_____</li> <li>_____</li> </ul> | <ul style="list-style-type: none"> <li>1. Label format no.</li> <li>2. Label length including pitch</li> <li>3. Item name returning line width (when registering)</li> <li>4. Label sensor distance</li> <li>5. Continuous paper label</li> <li>6. Store name/address print</li> <li>7. Field title print</li> <li>8. Peel sensor mode</li> <li>9. Default PLU (PLU for test printing)</li> <li>10. Thermal head fault check</li> </ul> |
|--------------------|--|---|

- b) Label format edit

- POS code

- a) Flag setting (Non-PLU)
- b) Flag setting (PLU)
- c) POS code system
- d) POS code type (Non-PLU)
- e) ITF code type (China specification)
- f) Manufacturer code

- Item code

- Reference data position in bar code

- Default data (Initial value of external reference data)

- a) Default value of date print flag
- b) Expiry date
- c) Processing time
- d) Expiry time

- Total addition

- Available/Not available

- Forced tare

- Available/Not available (USA specification)

- Unit price change prohibition (open price)

- Available/Not available

- Menu selection of PLU registration

- System (Registration menu selection)

- Ethernet setting
  - a) IP address
  - b) Gateway address setup
  - c) Subnet mask setup
  - d) Server address setup
  - e) Log-in name setup
  - f) Password setup
  - g) Mac address setup
  
- System timer
  
- Password setting
  - a) Password
  - b) Registration
  - c) Total
  - d) Subtraction
  - e) Setup
  - f) Tare

## 4.2 Starting Procedure for Each Mode

- Setup mode: Enter “6000”, and press the MODE key.
- Subtraction: Enter “7000”, and press the MODE key.
- Total: Enter “8000”, and press the MODE key.
- Registration: Enter “9000”, and press the MODE key.

## 4.3 Starting Procedure for Setup Mode

- Enter “6000”, and press the MODE key to enter SETUP MODE from normal or other mode.
- Press the [↓] key to increment a menu.

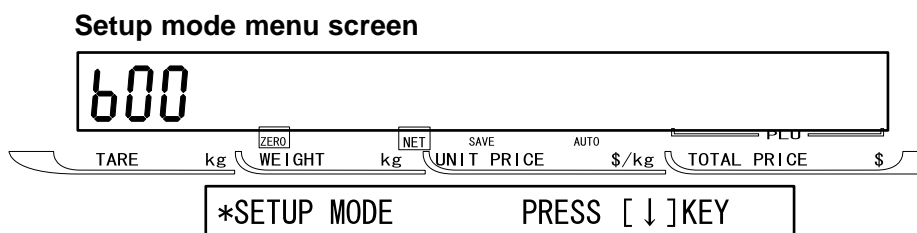

- Press the [↓] key to increment a menu, or enter a desired menu number followed by pressing the [↓] key.

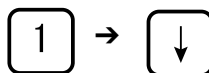

## 4.4 Label Format [Print conditions]

### ■Label print condition setting menu

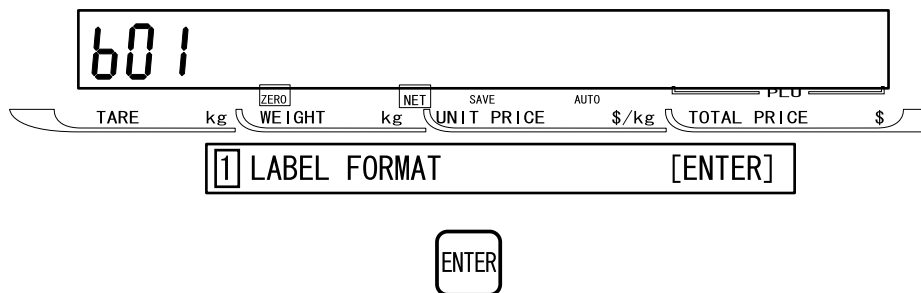

### ■PRINT SETUP [Print condition setting mode]

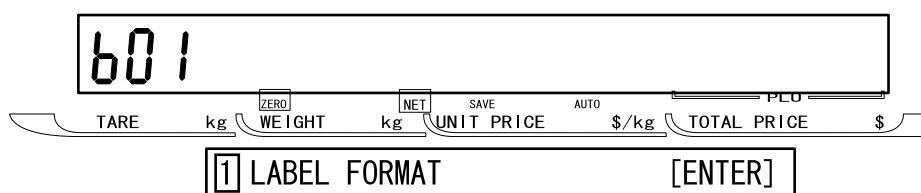

### ■LABEL FORMAT No. [Specifying label format number]

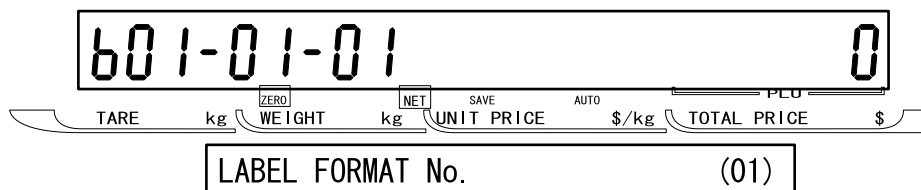

- #1 to #4" are standard formats. (# 10 to #99 can be additionally registered.)
- # 1 is a default when a format number in which there is no specified data.
- Enter the format number, and press the ENTER key.

### ■LABEL LENGTH + GAP [Setting label length]

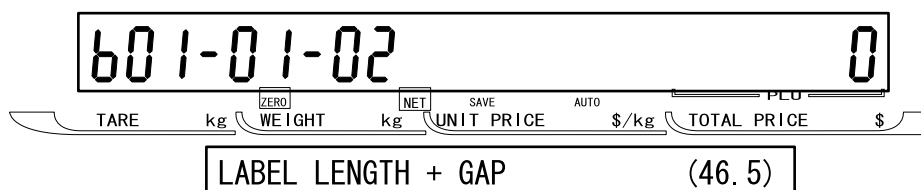

Enter the label length and label pitch in 0.1 mm unit.



■ LABEL WIDTH [Setting of item name area print width]

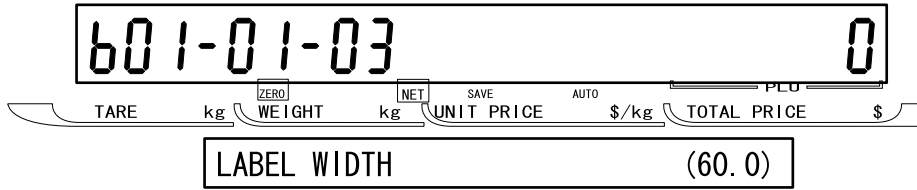

- This reflect an automatic line returning for an item name registration.
- When (0.0) is set, a line returning is carried out automatically based on the default value.

■ SENSOR (L) DISTANCE [Setting a distance between label sensor and thermal head]

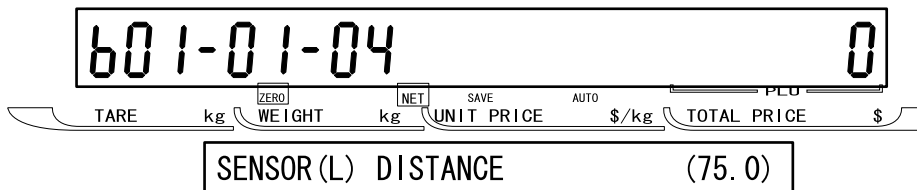

Enter a numerical value in 0.1 mm unit.

■ DIE-CUT, CONTINUOUS [Specifying label (Die-cut label/Continuous paper)]

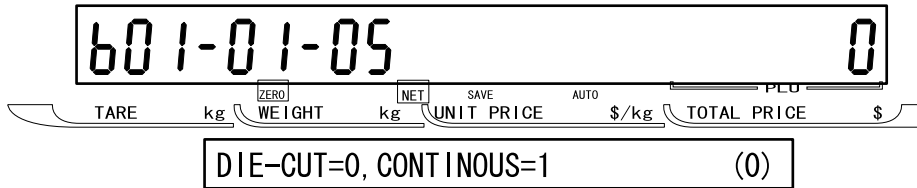

0/1 selection 0: Die-cut label 1: Continuous labels

■ STORE NAME, ADDRESS [Specifying whether to print store name/address or not]

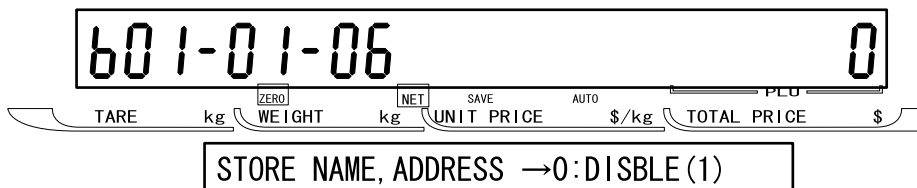

Availability selection 0: Disable 1: Enable

### ■FIELD TITLE PRINT [Specifying whether to print field title in advance or not]

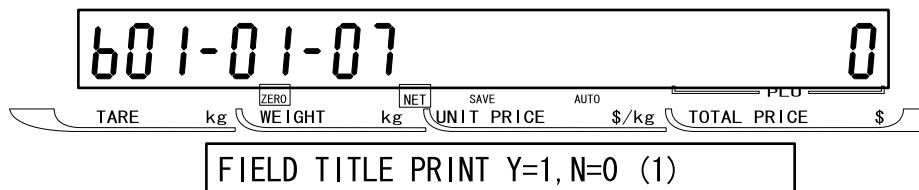

Yes/no selection 0: No 1: YES

### ■PEEL SENSOR [Availability setting of peel sensor]

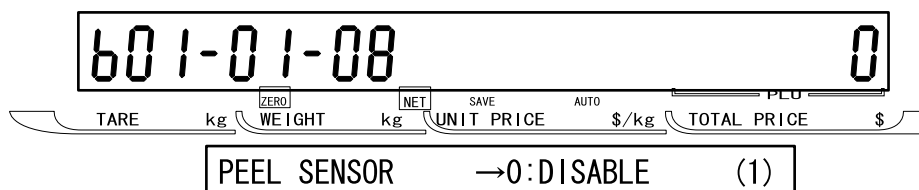

Availability selection 0: DISABLE 1: ENABLE

### ■TEST ITEM No. [Specifying PLU number for test print]

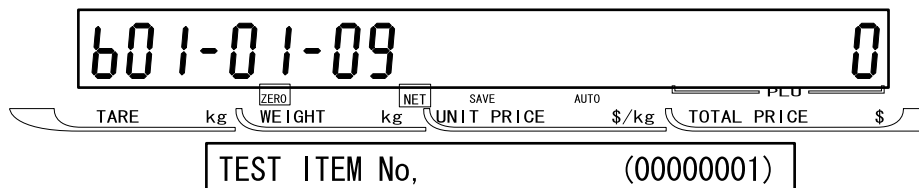

Enter a PLU number when performing test print.

### ■HEAD CHECK [Specifying availability of thermal head fault display]

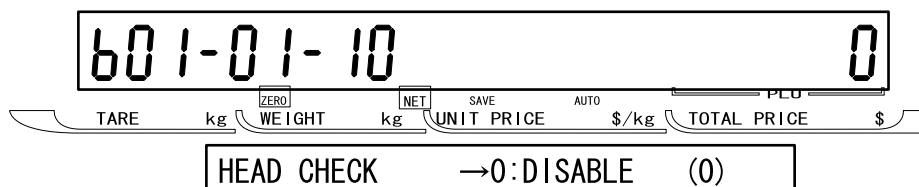

Availability selection 0: DISABLE (No error display) 1: ENABLE (Error display)

*Note: Thermal head is available only when "C06-00" No. 17 of the E2ROM switch is set "1".*

*\*No. 17 (Head fault check) 0: DISABLE 1: ENABLE*

■ LABEL FORMAT EDIT [Editing label format]

- How to enter label format edit mode.  
Enter a password “4141”, and press the SIZE key.

Note: A protection is released when the above operation has been performed.

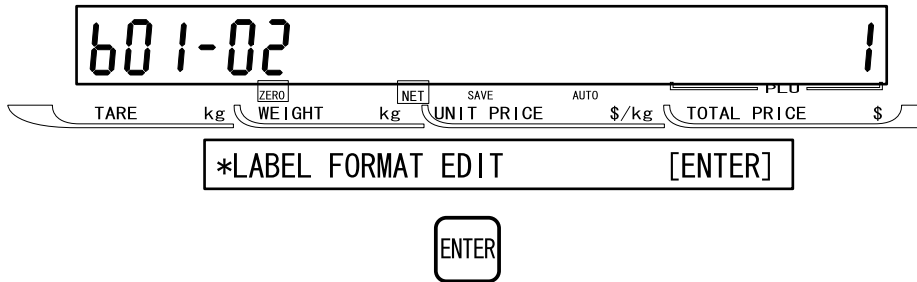

- Enter a label format number, and press the PLU key to call.

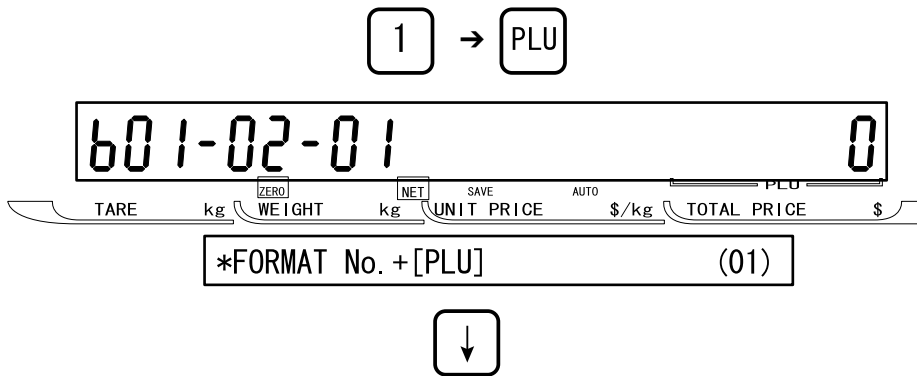

■ UNIT [X/ Y axis position selection]

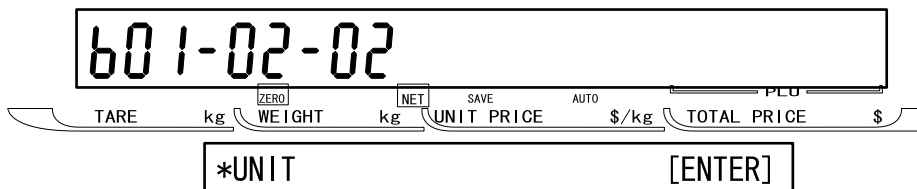

Press the ENTER key to select X or Y axis position.



## X AXIS POSITION

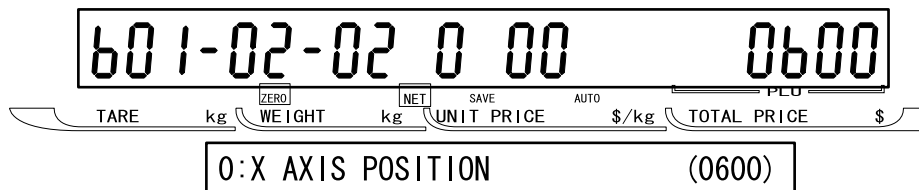

## Y AXIS POSITION

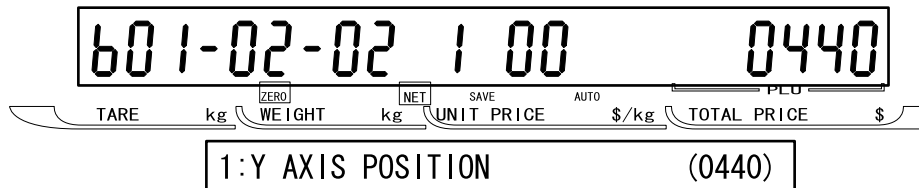

- Select “X axis position data” or “Y axis position data” using the [→] key.
- Multiple tube display  
 0 0: Label format unit # (1 to 50)  
 0600: X axis position is adjusted in 0.1mm unit.  
 0400: Y axis position is adjusted in 0.1mm unit.

## ■DEFAULT PLU

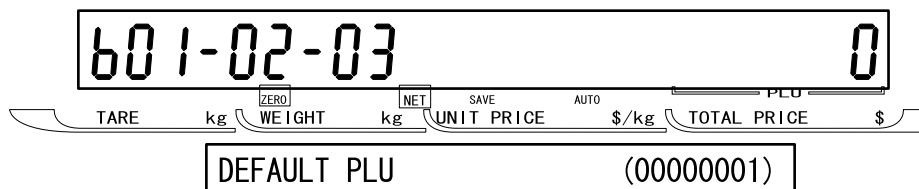

Specify a default PLU for test print.

## ■FORMAT No. + [PLU] [Copying format]

\*New label format edit (Example: Format No. 50)

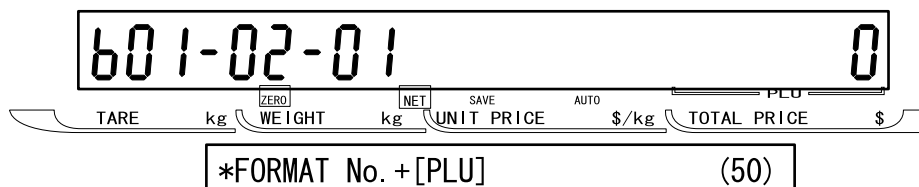

- Enter “50” and press the PLU key to call a label format.
- Enter “1” and press the COPY key to copy FORMAT No.1 data to FORMAT No.50.

## 4.5 POS Code

### ■POS setting mode menu

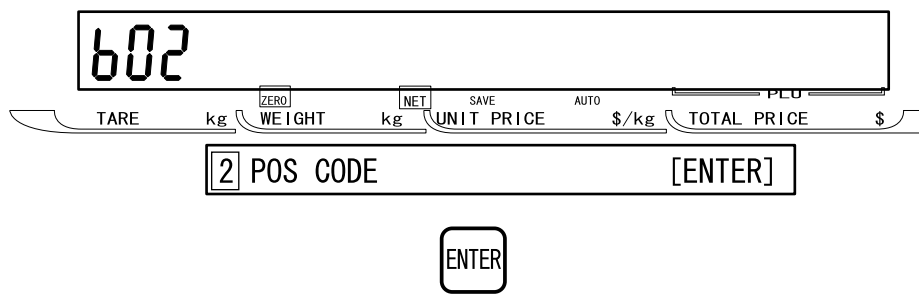

### ■NON-PLU FLAG

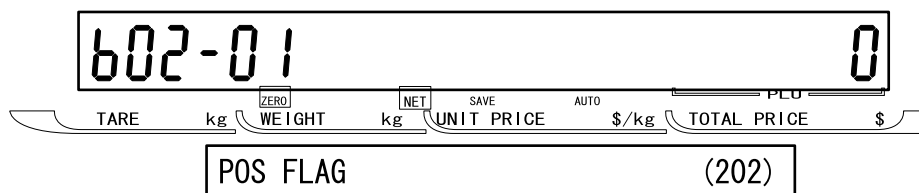

Set one or two digits if necessary.

### ■PLU FLAG [Setting a flag code for source marking]

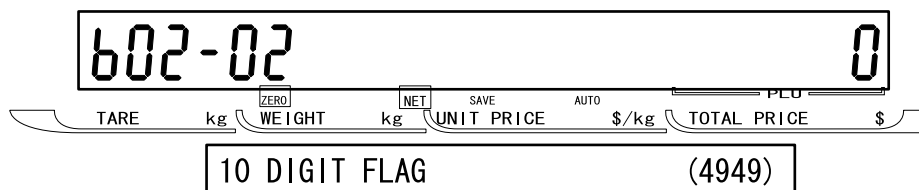

Set a flag code for source marking.

### ■POS TYPE [Setting a bar code type]

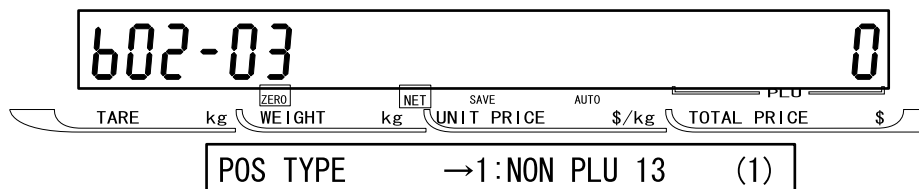

Bar code type selection

- 1: NON PLU 13
- 2: NON PLU 8
- 3: PLU 13
- 4: PLU 8
- 5: ITF 18

## ■BAR TYPE [Setting NON PLU 13 code]

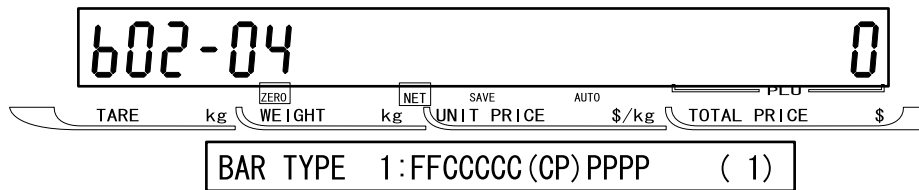

- Set the POS code type “NON PLU 13 code”.
- Meaning of abbreviation

F: Flag	M: Manufacturer code
C: Item code	(CP): Check price
P: Price	(0): 0
E: Weight	Q: Quantity
I: PLU no.	

- POS code type (NON PLU 13 code)

1. FFCCCC(CP)PPPP : Standard 5 digits
2. FFCCCCPPPP : 2 digit flag + 6 digit code + 4 digit price
3. FCCCCCC(CP)PPPP : 1 digit flag + 6 digit code + Check price + 4 digit price
4. FFCCCCPPPP : 2 digit flag + 5 digit code + 5 digit price
5. FCCCCCCPPPP : 1 digit flag + 6 digit code + 5 digit price
6. FFCCCC(CP)PPPP : 2 digit flag + 4 digit code + Check price + 5 digit price
7. FFCCCCCWWWW : 2 digit flag + 6 digit code + 4 digit weight
8. FCCCCCCWWWW : 1 digit flag + 6 digit code + 5 digit weight
9. FCCCCCCIIIII : 1 digit flag + 5 digit code + 6 digit PLU
10. FFCCCCPPPP : 2 digit flag + 6 digit code + 4 digit price EAN
11. FFCCCCCWWWW : 2 digit flag + 6 digit code + 4 digit weight EAN

*Note: In a normal barcode, if the price or weight becomes over fixed digits, the barcode will not be printed out. For example, 4-digit prices will only print out up to 9,999. Barcodes will not be printed for prices over 10,000. In “EAN” code, prices over a given digit number will only print out the upper digits. Therefore, if the price is 10,000, the barcode (EAN code) will be printed as 1,000. Note that EAN code flags are fixed 2X. When one lower digit is deleted, the second digit of the flag will be increased.*

12. FFCCCC(CP)WWWW : 4 digit item code + (CP) + 5 digit weight
13. FFMCCPPPP : 2 digit flag + 3 digit manufacturer code + 2 digit code + 5 digit price
14. FFMCCPPPP : 2 digit flag + 2 digit manufacturer code + 3 digit code + 5 digit price
15. FFCCCC(0)PPPP : 2 digit flag + 5 digit code + 0 + 4 digit price
16. FFCCCCWWWW : 2 digit flag + 5 digit code + 5 digit weight
17. FFCCCCPPPP : 2 digit flag + 5 digit code + 5 digit price

*Note: The least significant digit of the total amount is omitted for barcode printing.*

18. FFCCCC(CP)PPPP : 2 digit flag + 5 digit code + Check price + 4 digit price  
*Note: The least significant digit of the total amount is omitted for barcode printing.*
19. FFCCCC(CP)WWWW : 2 digit flag + 5 digit code + Check price + 4 digit weight
20. FCCCCCCPPPP : 1 digit flag + 5 digit code + 6 digit price
21. FFCCCCPPPP : 2 digit flag + 4 digit code + 6 digit price
22. FCCCWWWWPPPP : 1 digit flag + 3 digit code + 4 digit weight + 4 digit price
23. FFCCCCQPPPP : 2 digit flag + 4 digit code + 2 digit quantity + 4 digit price
24. FIIIIIPPPPP : 1 digit flag + 6 digit PLU + 5 digit price
25. FFIIIIIPPPPP : 2 digit flag + 6 digit PLU + 4 digit price
26. FCCCPPPPPP : 1 digit flag + 4 digit code + 7 digit price
27. FIIIIIPPPPP : 1 digit flag + 6 digit PLU + 5 digit price (1/10)
28. FFIIIIIPPPPP : 2 digit flag + 6 digit PLU + 4 digit price (1/10)
29. FCCCCCCPPPP : 1 digit flag + 6 digit code + 5 digit price (1/10)
30. FFCCCCPPPP : 2 digit flag + 6 digit PLU + 4 digit price (1/10)
31. FFCCCCQQQQ : 2 digit flag + 5 digit code + 5 digit quantity

■ITF [Setting ITF code]

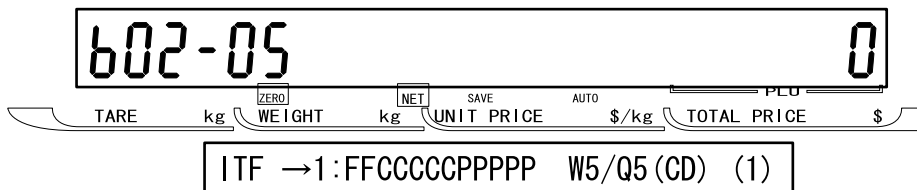

- Set an ITF code type “NON PLU 18 code”.

- Meaning of abbreviation

F: Flag	M: Manufacturer code
C: Item code	Q: Quantity
P: Price	U: Unit price
W: Weight	(CD): Check digit

- POS code type (Non PLU 13 code)

1. FFCCCCPPPPP W5/Q5: “3” or “4” is automatically selected. (Weighing/fixed price item)
2. FFCCCCUUUUUWWWWW(CD): 2 digit flag + 5 digit code + 5 digit unit price + 5 digit weight
3. FFCCCCPPPPPWWWWW(CD): 2 digit flag + 5 digit code + 5 digit price + 5 digit weight
4. FFCCCCPPPPPQQQQQ(CD): 2 digit flag + 5 digit code + 5 digit price + 5 digit quantity

- The FFCCCCPPPPPQQQQQ(CD) type ITF barcode is printed for a fixed price item when ITF is set “1”. And the FFCCCCPPPPPWWWWW(CD) type ITF barcode is printed for an weighing item.

■MANUFACTURE CODE

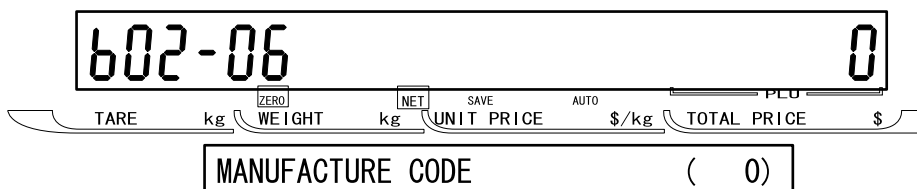

Specify a manufacturer code.

## 4.6 Barcode [Item code]

### ■Item code setting menu

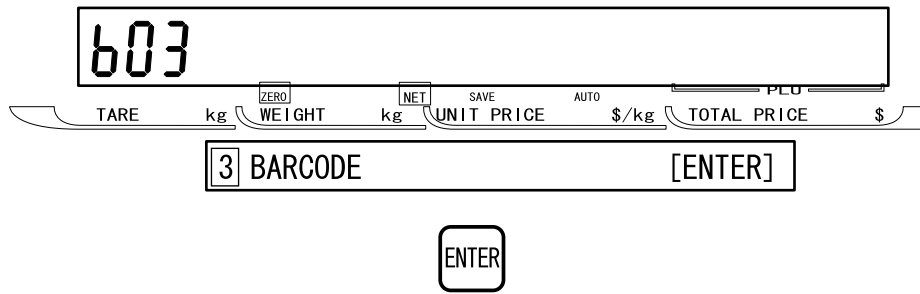

### ■POSITION [Setting an item code]

- Set "Position" and "Number of digits" of the item code reflected in the bar code

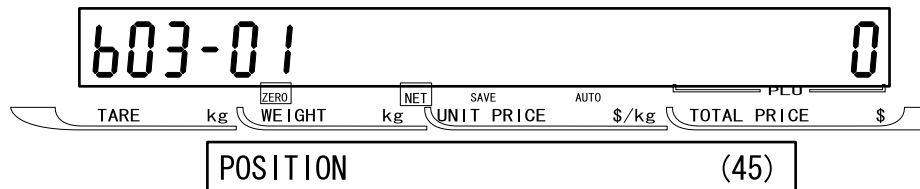

- "45" is a default value specifying the five digits from the fourth digit in 8 digit item code are taken into the bar code.
- For example, "45678" is taken for the barcode from "123454678".



## 4.7 Default Data

### ■Default data setting menu

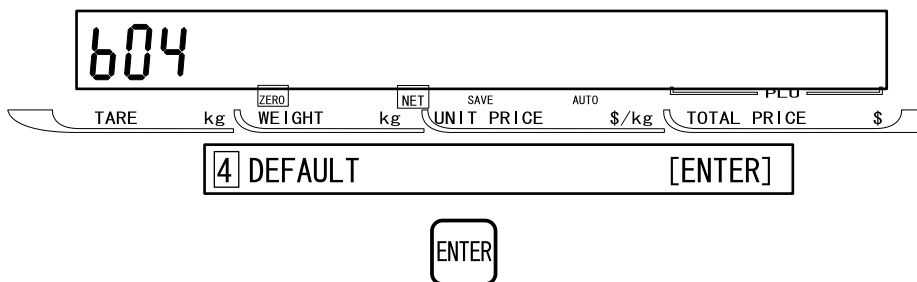

### ■POSITION [Setting an item code]

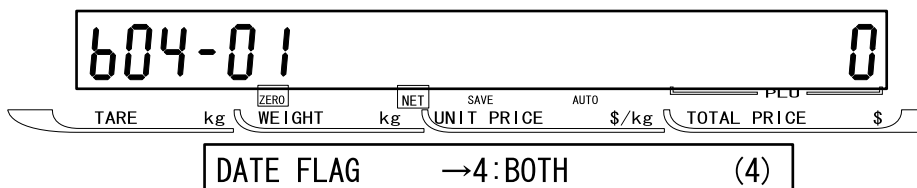

Date print

- 1: Print prohibited
- 2: Packing date print
- 3: Expiry date print
- 4: Both packing date and expiry date print = defaults

### ■SHELF LIFE [Setting the number of days for expiry date]

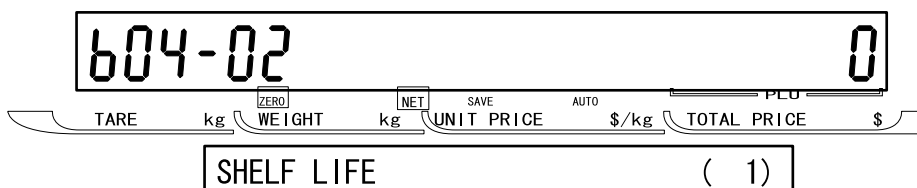

Specify the number of days for an expiry date. "1" denotes "Today".

### ■PACKING TIME FLAG [Setting a print flag for packing time print]

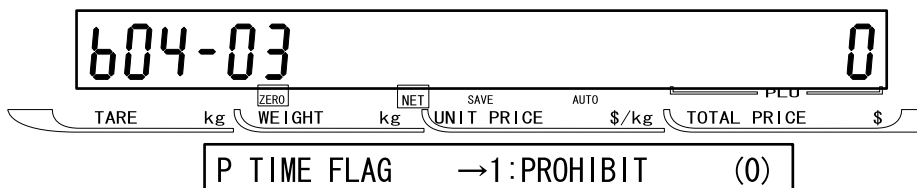

- Packing time
- 1: Prohibit
  - 2: Installed
  - 3: Designated

### ■EXPIRY TIME FLAG [Setting a flag for expiry time print]

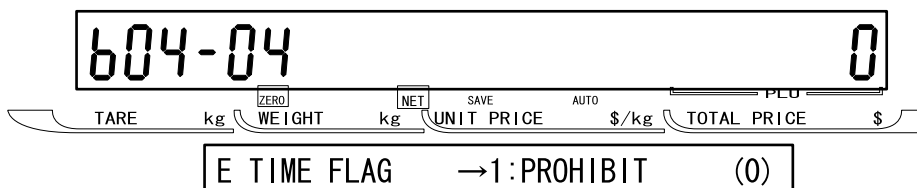

- Expiry time
- 1: Prohibit
  - 2: Designated
  - 3: Relative

## 4.8 Total Mode Select

### ■Total setting menu

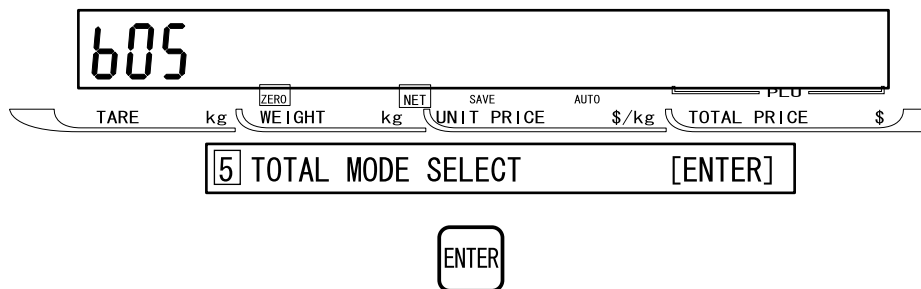

### ■DAILY TOTAL [Selection of total availability]

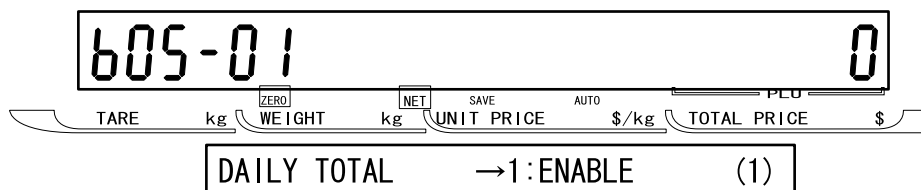

Select availability of daily total when issuing labels. (Default value 1: Enable)  
0: Disable 1: Enable

## 4.9 Forced Tare [USA specification only]

### ■Forced tare setting menu

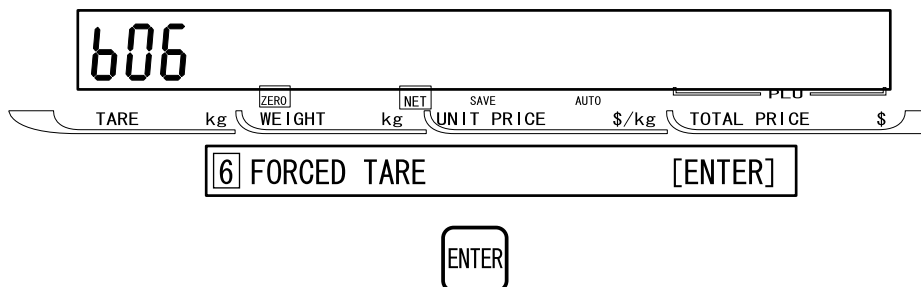

### ■FORCED TARE [Selection of availability]

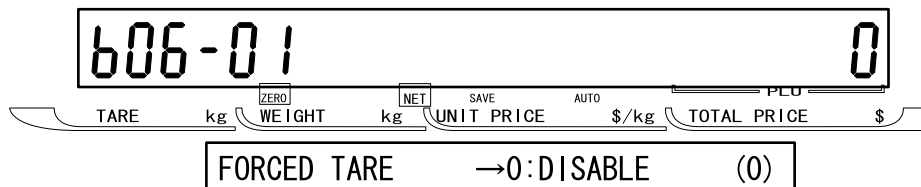

0: No forced tare (Default) 1: Forced tare

## 4.10 Open Price [Prohibition of Unit Price Change]

### ■Unit price change prohibition setting menu

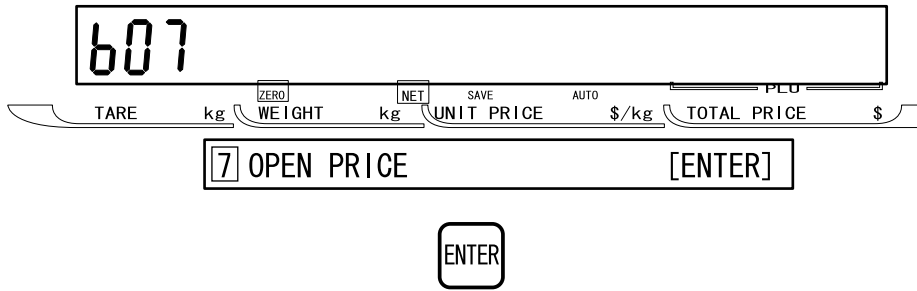

### ■OPEN PRICE [Selection of open price or unit price change prohibition]

- Select a temporary unit price change or a open price in normal mode.

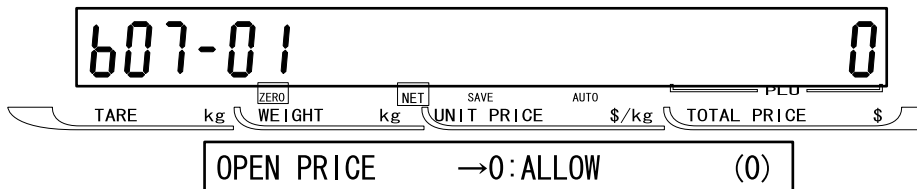

0: Open price (Allow) ..... Default

1: Temporary unit price change prohibited (Prohibit)

## 4.11 PLU Select [Editing PLU File]

### ■PLU file edit menu

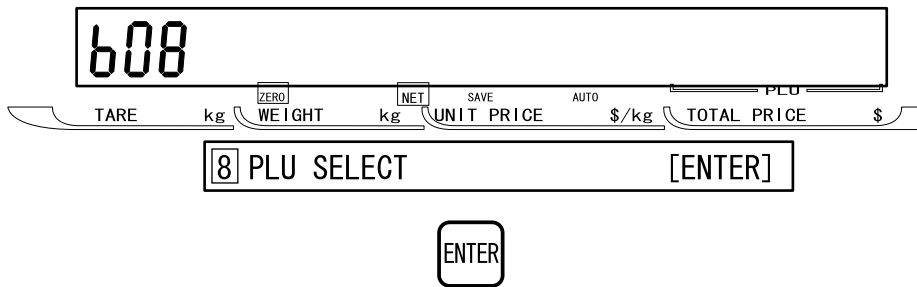

### ■SALES MODE

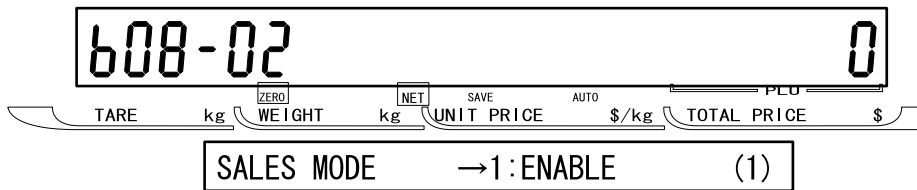

Selection 0: Disable 1: Enable

### ■PRICE

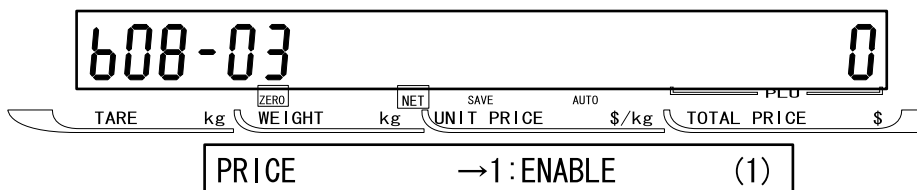

Selection 0: Disable 1: Enable

### ■MD (Mark Down) FLAG

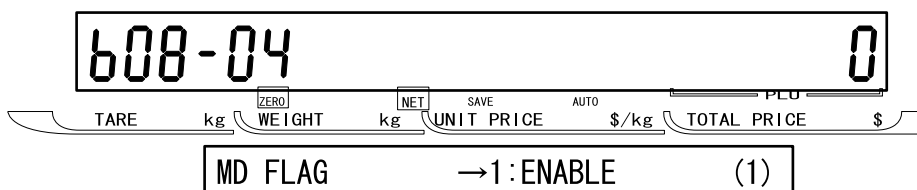

Selection 0: Disable 1: Enable

### ■MD (Mark Down) PRICE

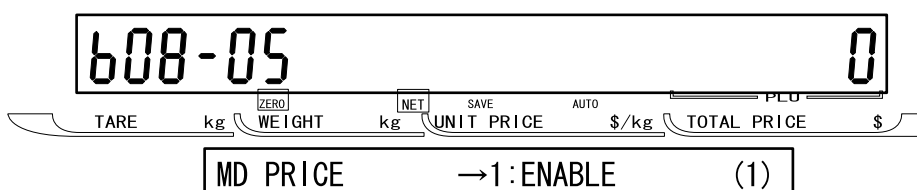

Selection 0: Disable 1: Enable

■FIXED WEIGHT

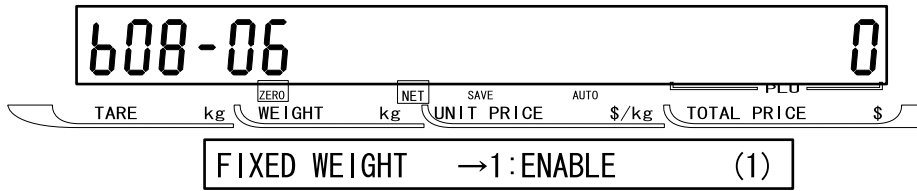

Selection 0: Disable 1: Enable

■PCS (Quantity)

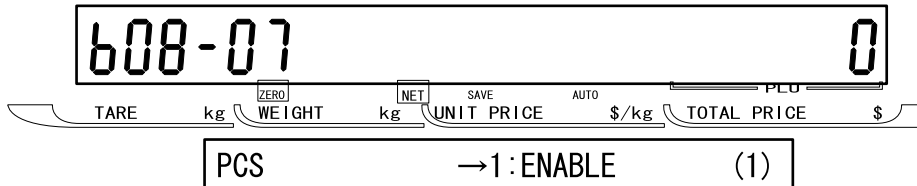

Selection 0: Disable 1: Enable

■TARE

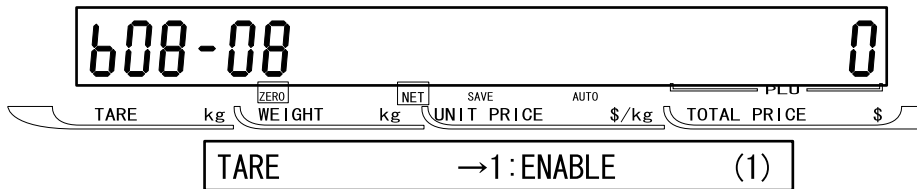

Selection 0: Disable 1: Enable

■DATE PRINT

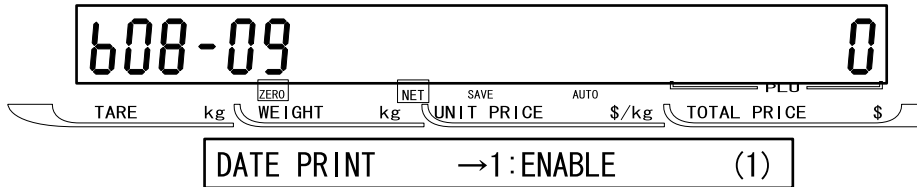

Selection 0: Disable 1: Enable

■SHELF LIFE

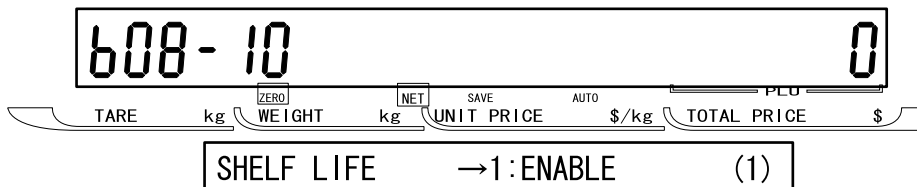

Selection 0: Disable 1: Enable

### ■BEST BEFORE DATE FLAG

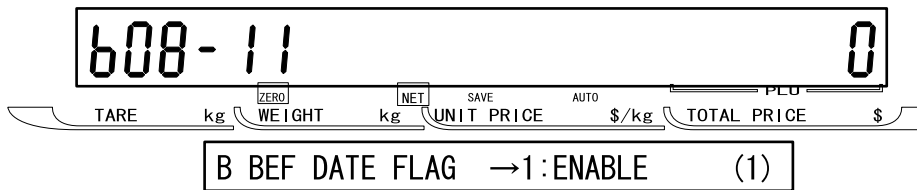

Selection 0: Disable 1: Enable

### ■BEST BEFORE DATE

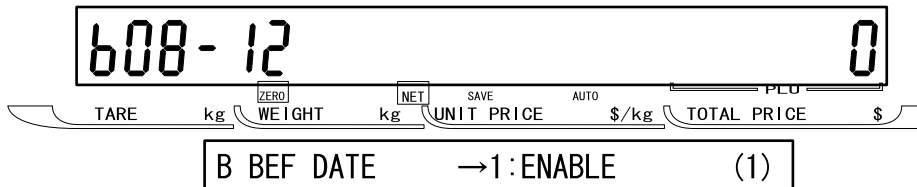

Selection 0: Disable 1: Enable

### ■PACKING TIME FLAG

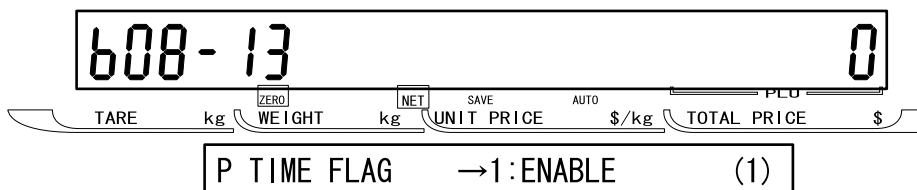

Selection 0: Disable 1: Enable

### ■PACKING TIME DATE

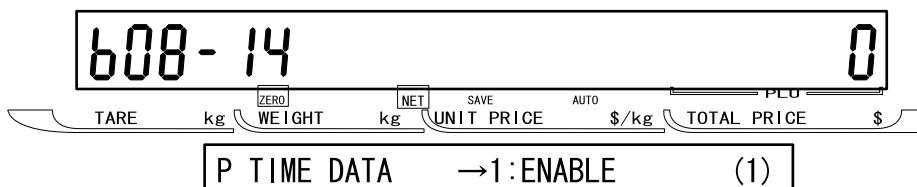

Selection 0: Disable 1: Enable

### ■EXPIRY TIME FLAG

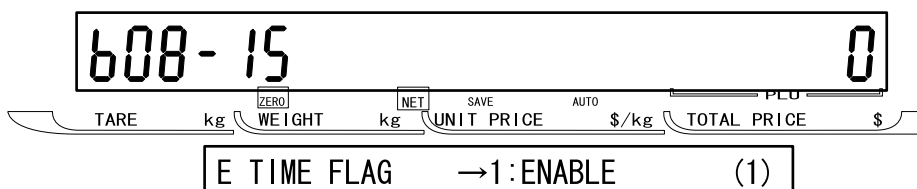

Selection 0: Disable 1: Enable

■EXPIRY TIME DATA

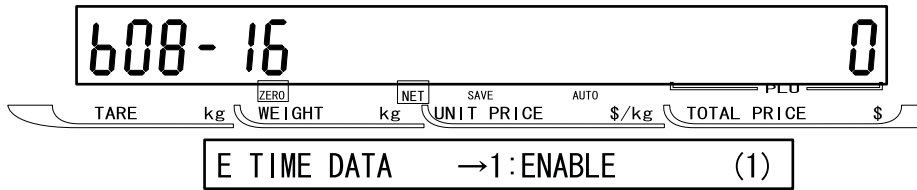

Selection 0: Disable 1: Enable

■ITEM CODE

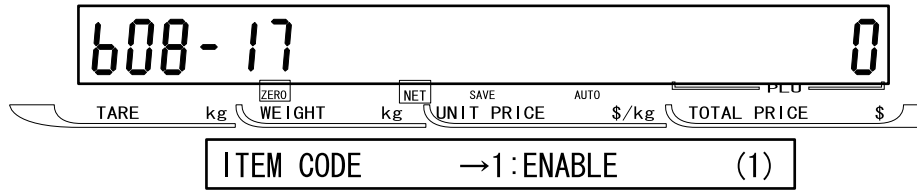

Selection 0: Disable 1: Enable

■BARCODE TYPE

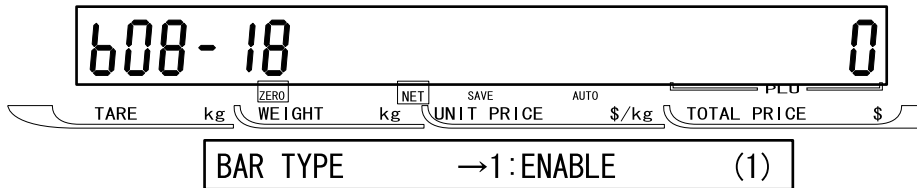

Selection 0: Disable 1: Enable

■POS CODE TYPE

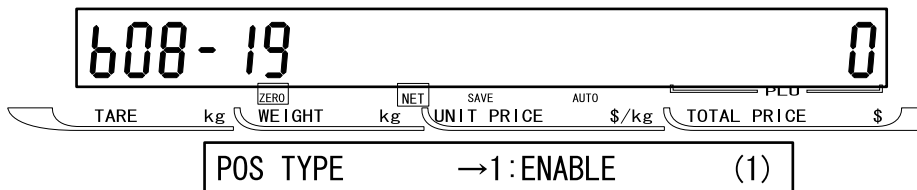

Selection 0: Disable 1: Enable

■POS CODE FLAG

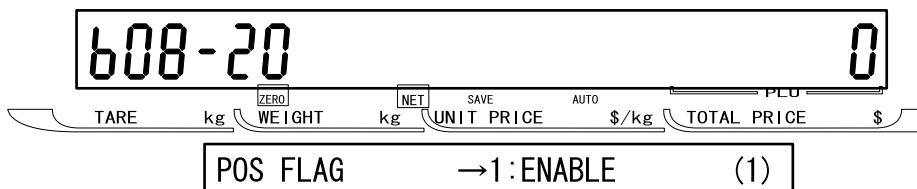

Selection 0: Disable 1: Enable

### ■ POS CODE

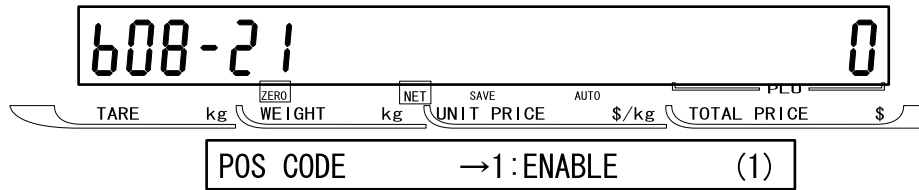

Selection 0: Disable 1: Enable

### ■ OPEN PRICE

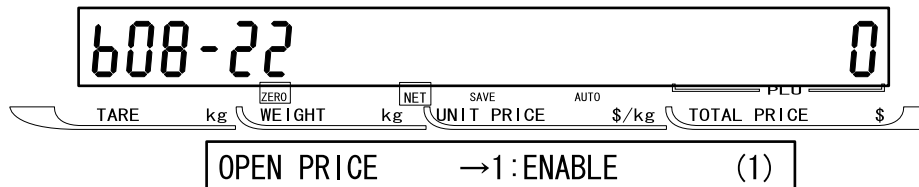

Selection 0: Disable 1: Enable

### ■ EXTRA MESSAGE 1

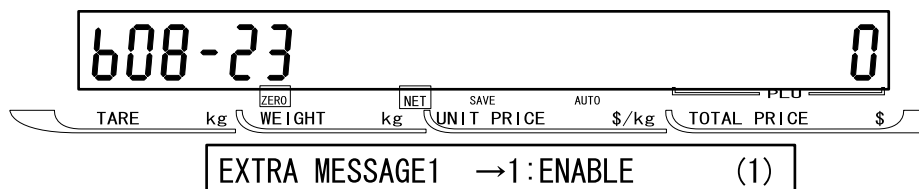

Selection 0: Disable 1: Enable

### ■ EXTRA MESSAGE 2

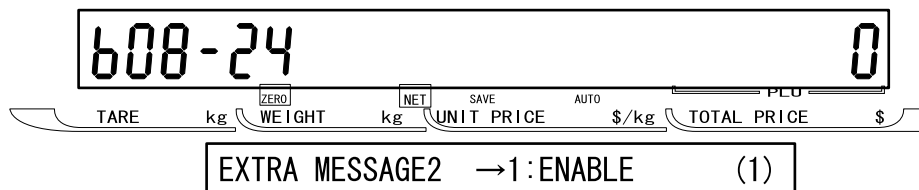

Selection 0: Disable 1: Enable

### ■ EXTRA MESSAGE 3

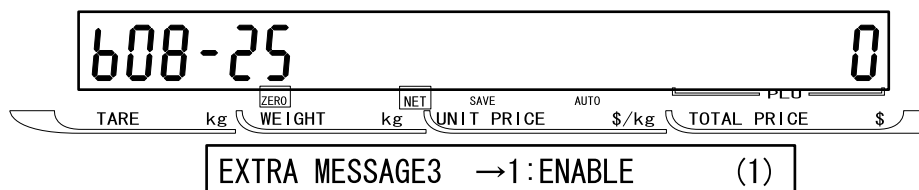

Selection 0: Disable 1: Enable



■COUPON MESSAGE

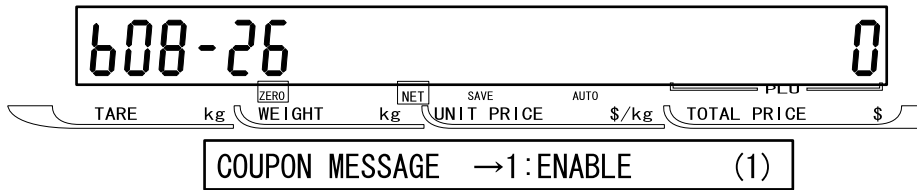

Selection 0: Disable 1: Enable

■LOGO IMAGE 1

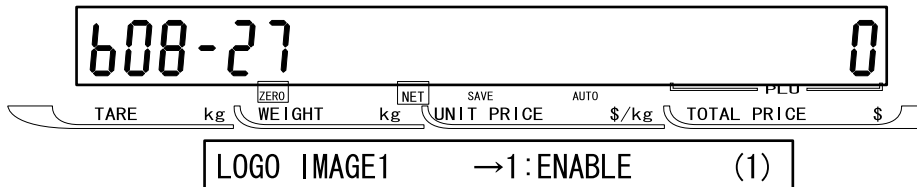

Selection 0: Disable 1: Enable

■LOGO IMAGE 2

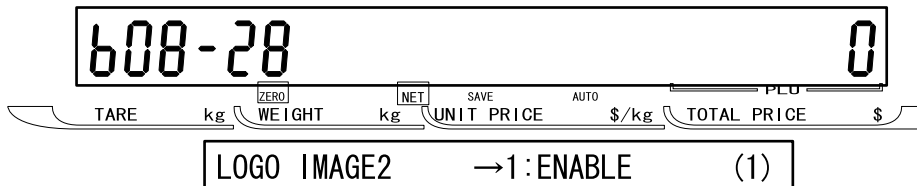

Selection 0: Disable 1: Enable

■LABEL FORMAT No.

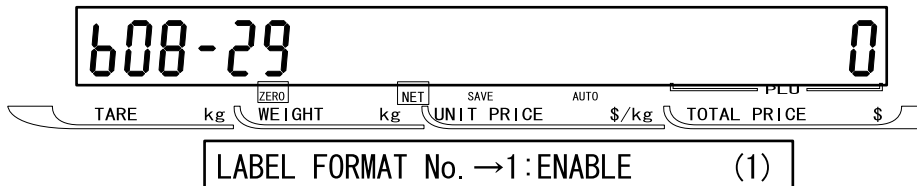

Selection 0: Disable 1: Enable

■UPPER LIMIT

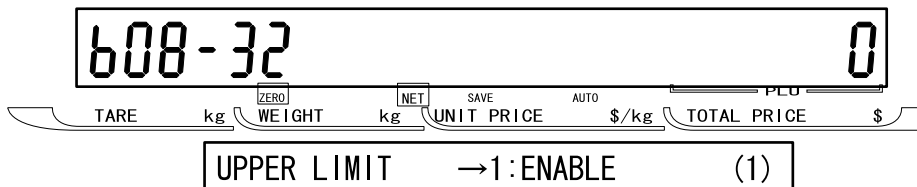

Selection 0: Disable 1: Enable

### ■LOWER LIMIT

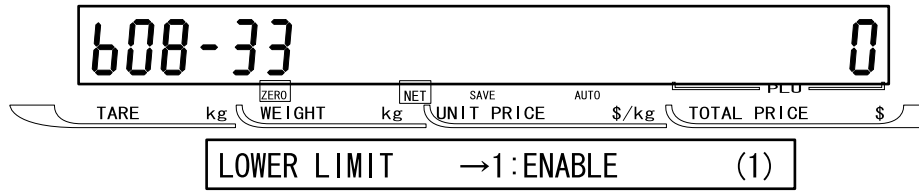

Selection 0: Disable 1: Enable

### ■POP No.

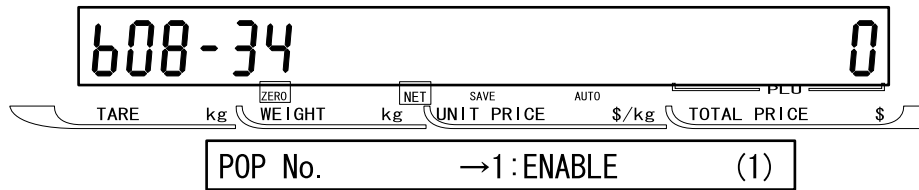

Selection 0: Disable 1: Enable

## 4.12 System [Availability of Registration Mode Menu]

### ■PLU file edit menu

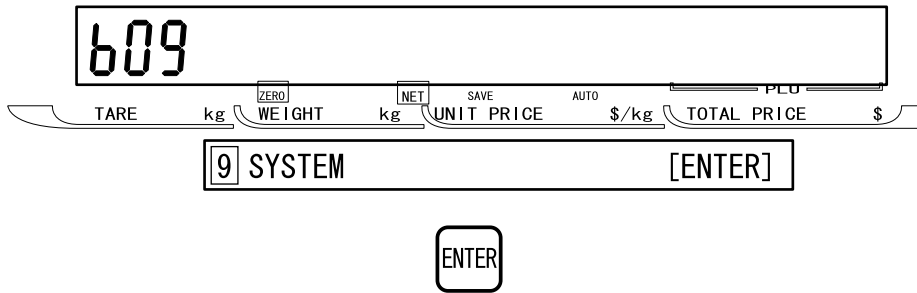

### ■PLU

- A function to protect PLU data.

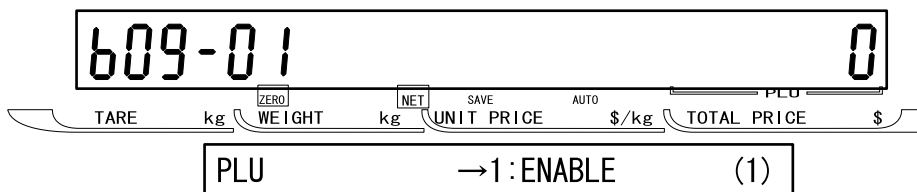

Selection 0: Disable 1: Enable

Note: P01 and P03 mode can not be used.

### ■COMMODITY

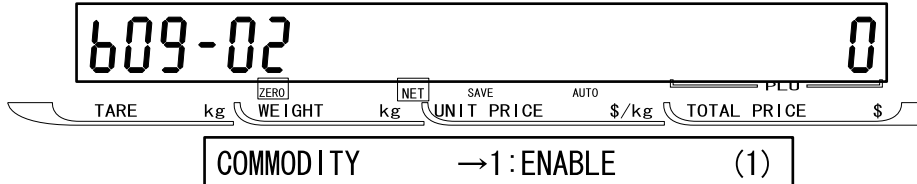

Selection 0: Disable 1: Enable (Default)

### ■PRESET KEY

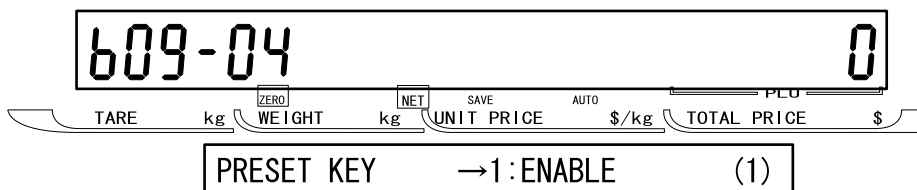

Selection 0: Disable 1: Enable

### ■STORE ADDRESS

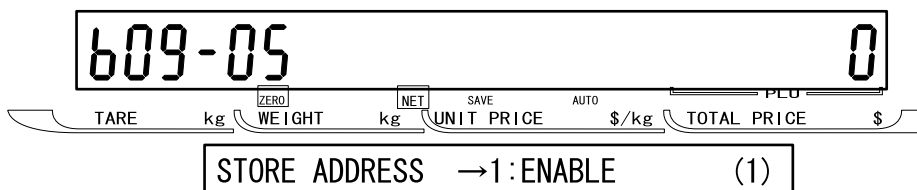

Selection 0: Disable 1: Enable

### ■DATE

609-06 0

TARE kg <sup>ZERO</sup> WEIGHT kg <sup>NET</sup> UNIT PRICE \$/kg <sup>SAVE</sup> <sup>AUTO</sup> TOTAL PRICE \$ <sup>PLU</sup>

DATE →1:ENABLE (1)

Selection 0: Disable 1: Enable

### ■EXTRA MESSAGE 1

609-07 0

TARE kg <sup>ZERO</sup> WEIGHT kg <sup>NET</sup> UNIT PRICE \$/kg <sup>SAVE</sup> <sup>AUTO</sup> TOTAL PRICE \$ <sup>PLU</sup>

EXTRA MESSAGE1 →1:ENABLE (1)

Selection 0: Disable 1: Enable

### ■OPEN PLU

609-08 0

TARE kg <sup>ZERO</sup> WEIGHT kg <sup>NET</sup> UNIT PRICE \$/kg <sup>SAVE</sup> <sup>AUTO</sup> TOTAL PRICE \$ <sup>PLU</sup>

OPEN PLU →1:ENABLE (1)

Selection 0: Disable 1: Enable

### ■ITEM LIST

609-09 0

TARE kg <sup>ZERO</sup> WEIGHT kg <sup>NET</sup> UNIT PRICE \$/kg <sup>SAVE</sup> <sup>AUTO</sup> TOTAL PRICE \$ <sup>PLU</sup>

ITEM LIST →1:ENABLE (1)

Selection 0: Disable 1: Enable

### ■RS232C COMMUNICATION

609-10 0

TARE kg <sup>ZERO</sup> WEIGHT kg <sup>NET</sup> UNIT PRICE \$/kg <sup>SAVE</sup> <sup>AUTO</sup> TOTAL PRICE \$ <sup>PLU</sup>

RS232C COMM →1:ENABLE (1)

Selection 0: Disable 1: Enable

■COUPON MESSAGE

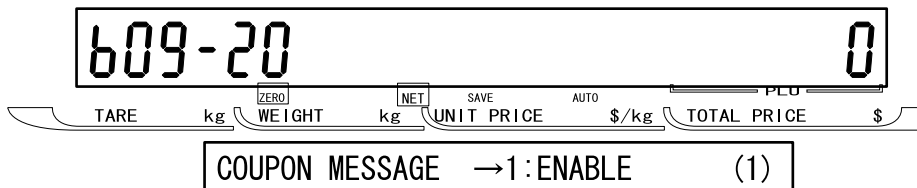

Selection 0: Disable 1: Enable

■EXTRA MESSAGE 2

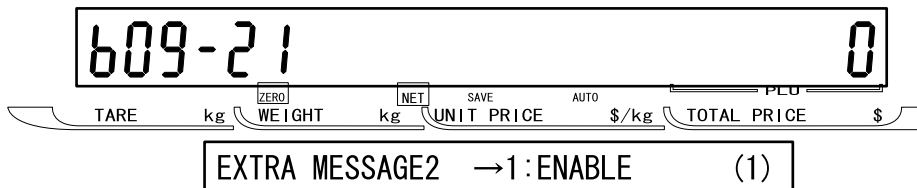

Selection 0: Disable 1: Enable

■EXTRA MESSAGE 3

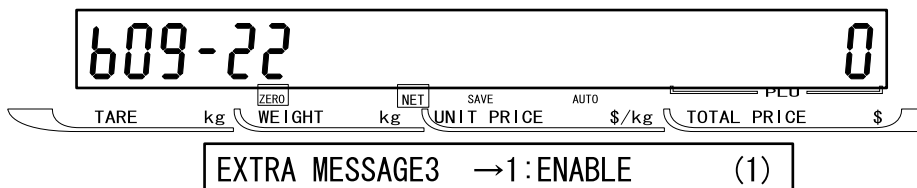

Selection 0: Disable 1: Enable

■TCP/IP COMMUNICATION

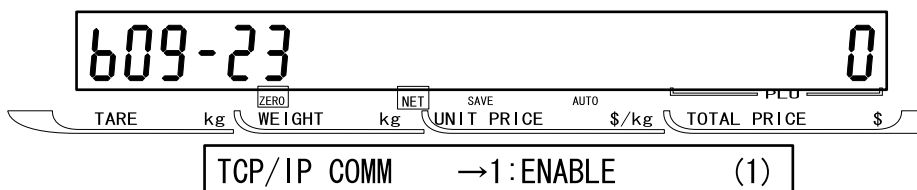

Selection 0: Disable 1: Enable

■OPERATOR

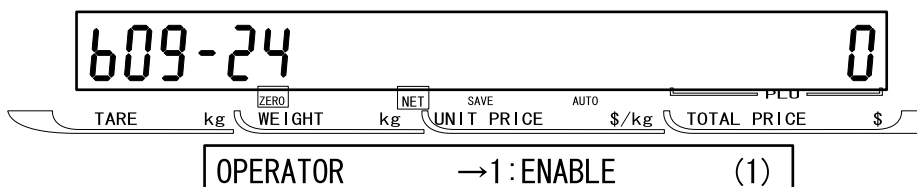

Selection 0: Disable 1: Enable

### ■TITLE MESSAGE

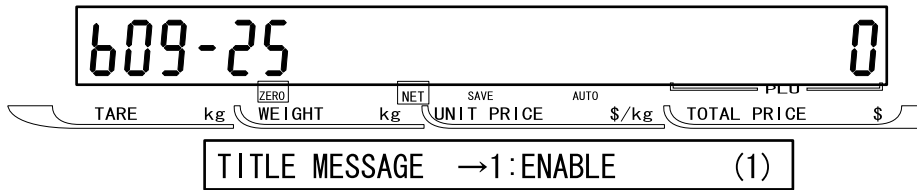

Selection 0: Disable 1: Enable

### ■ADVERTISEMENT MESSAGE 2

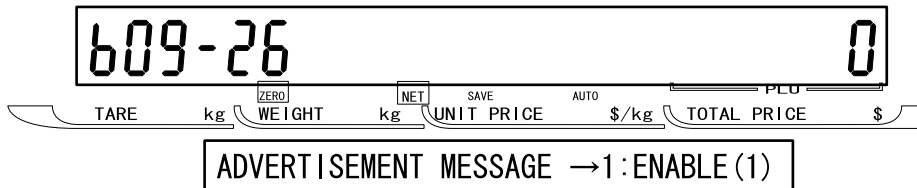

Selection 0: Disable 1: Enable

## 4.13 Ethernet Setup [Ethernet Data Setting]

### ■Ethernet data setting menu

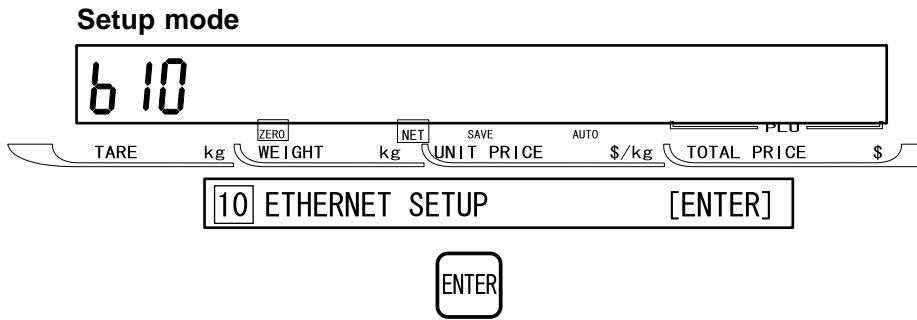

### ■IP ADDRESS SETUP

- Set an Internet Protocol address.

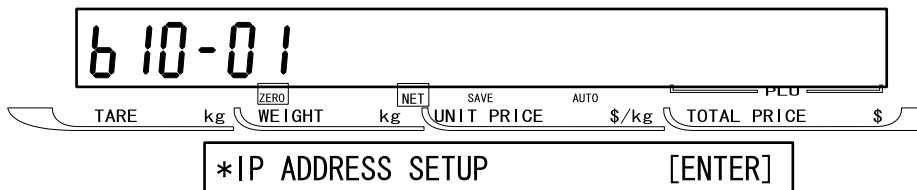

- Enter an Internet Protocol address. (Enter a data divided with the period individually.)

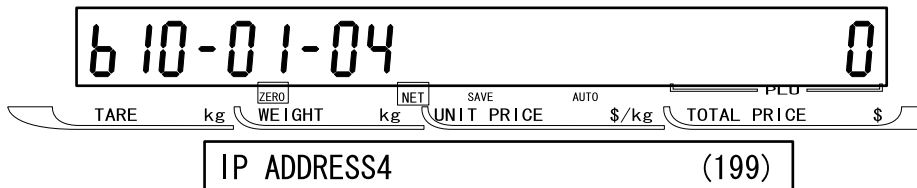
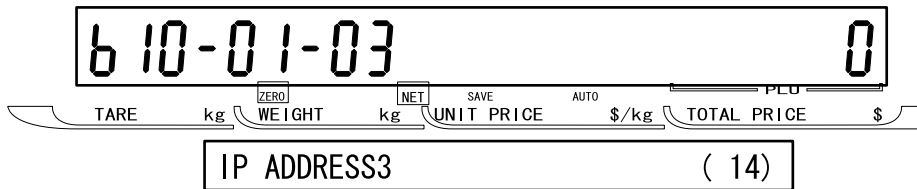
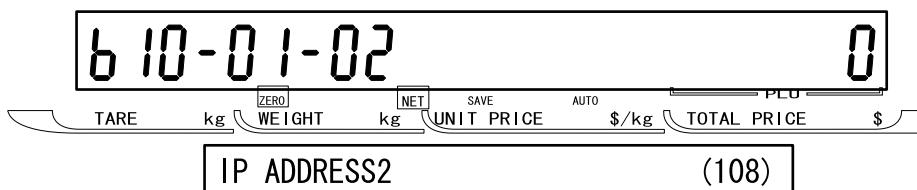
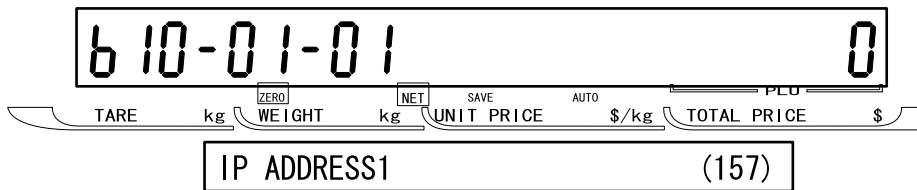

- Set a gateway address.

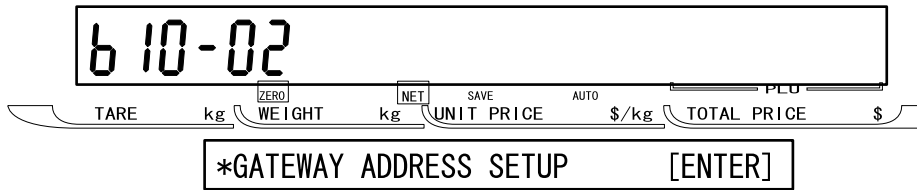

- Enter a gateway address. (Enter a data divided with the period individually.)

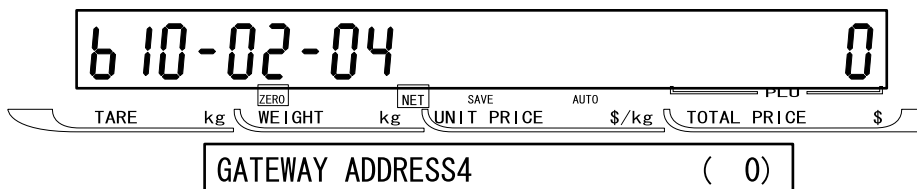
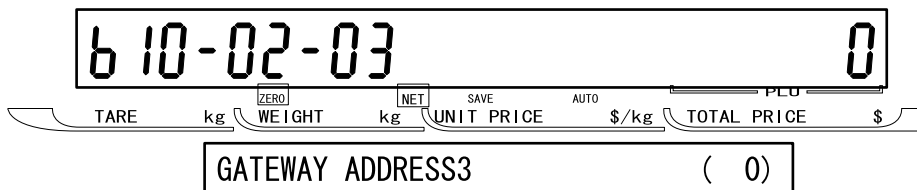
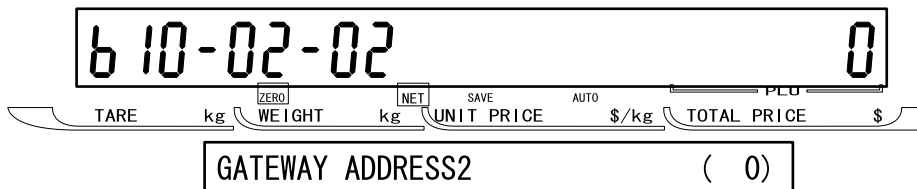
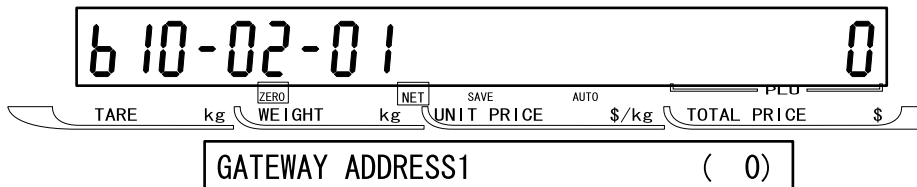



- Set a subnet mask.

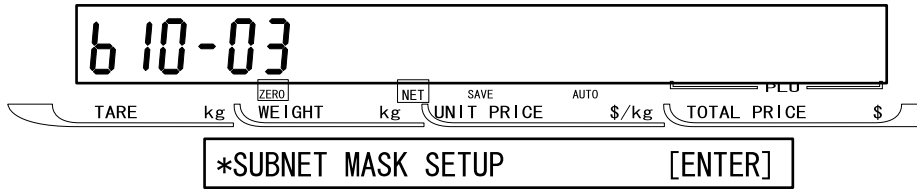

- Enter a subnet mask. (Enter a data divided with the period individually.)

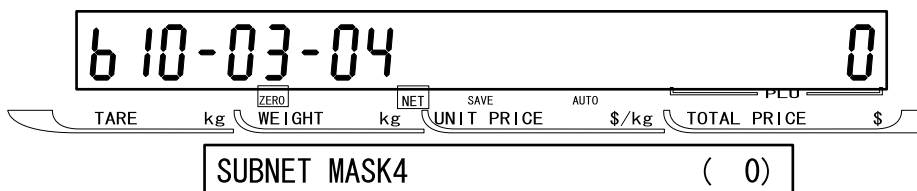
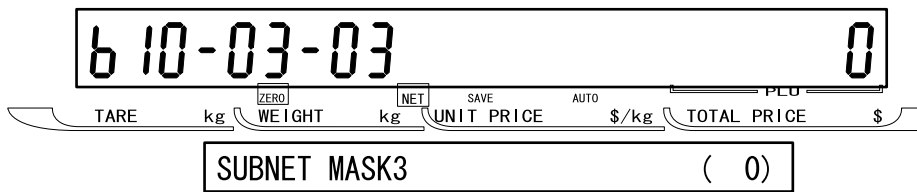
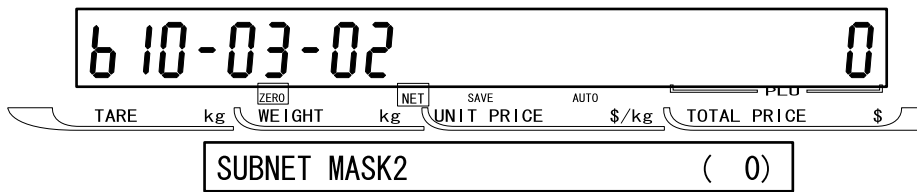
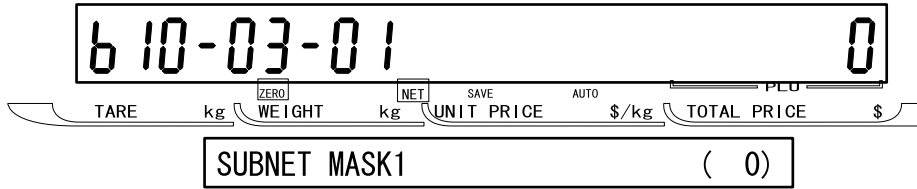

- Set a server address.

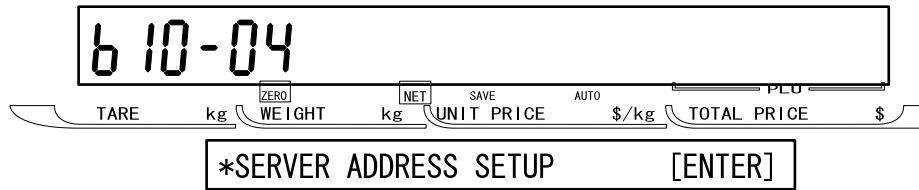

- Enter a server address. (Enter a data divided with the period individually.)

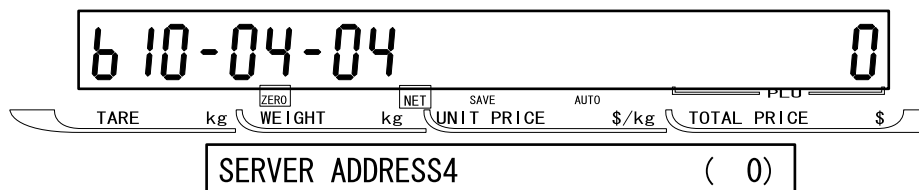
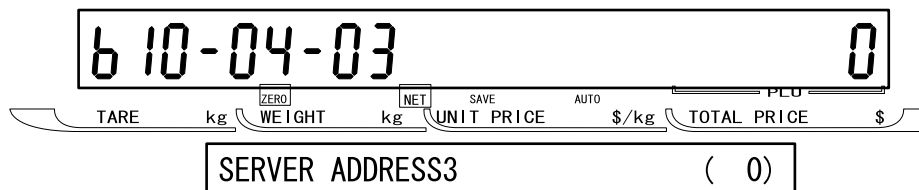
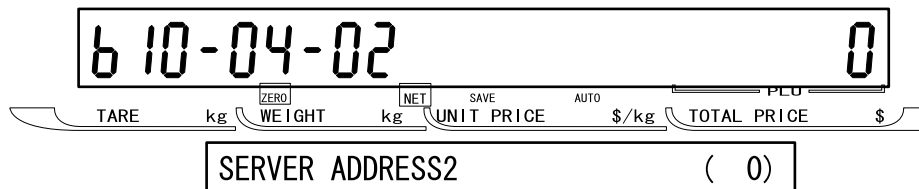
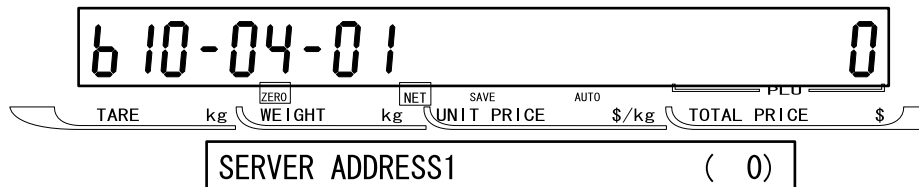

- Set a log-in name.

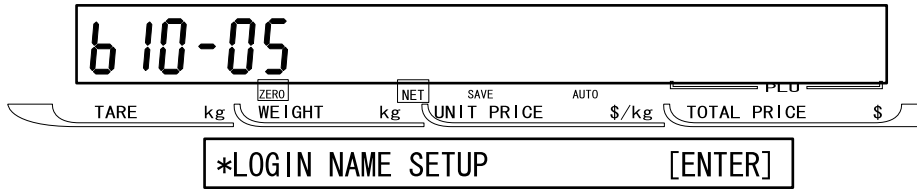

- Enter a log-in name. (Enter a log-in name using numeric or character keys. (Entered characters must be small letters))

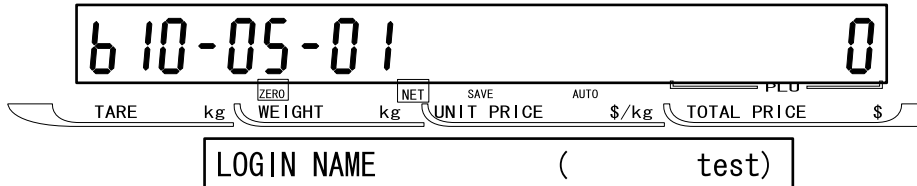

- Set a password.

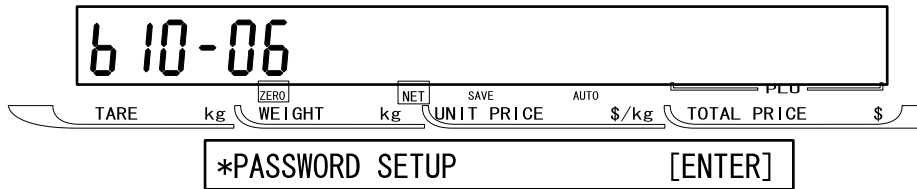

- Enter a password. (Enter a password using numeric or character keys. (Entered characters must be small letters))

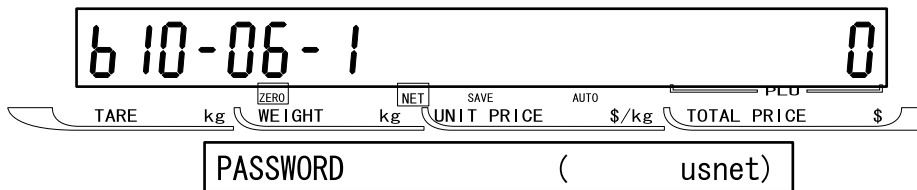

- Checking MAC address
- As the MAC address is unique to the CPU board, modified use is strictly prohibited. When the board is exchanged, Use the MAC address memorized in a new board. If the stored data is cleared due to any trouble of the board, it is possible to set an address. In this case, release a protection by entering a password.
- Enter a password “495344”, and press the SIZE key.

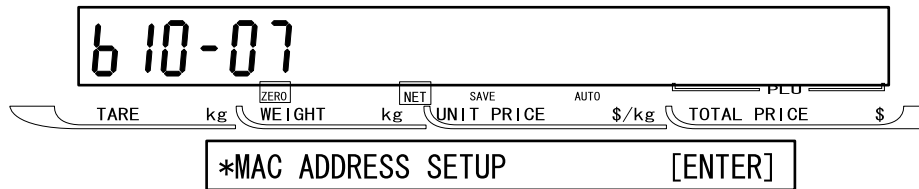

- Enter a MAC address. (Enter the data divided with the period individually.)

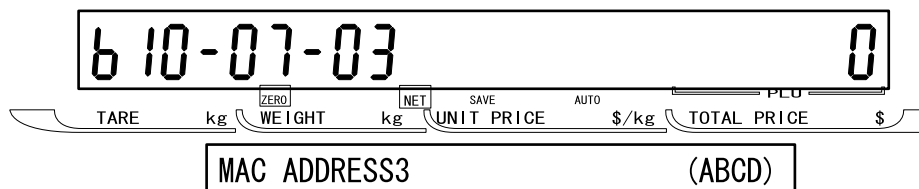
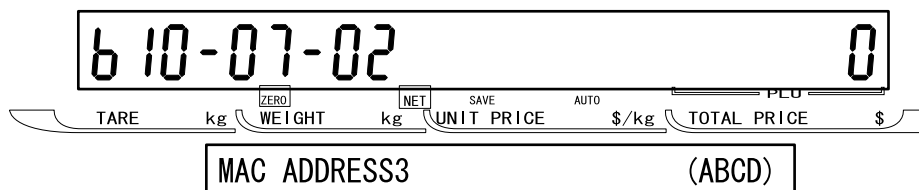
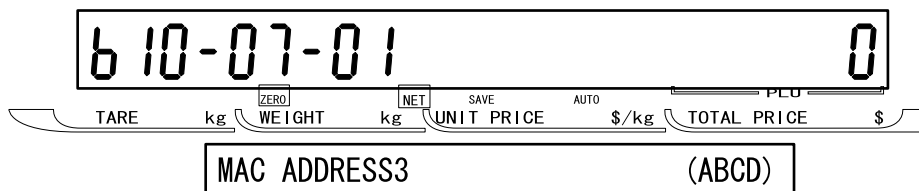

## 4.14 System Timer

### ■System timer setting menu

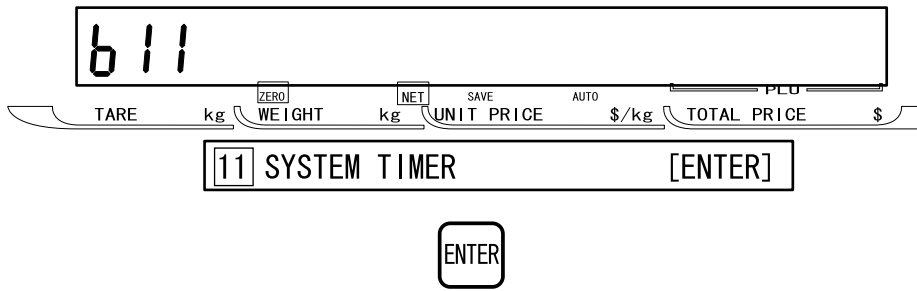

### ■SYSTEM TIMER

- Set the system timer.

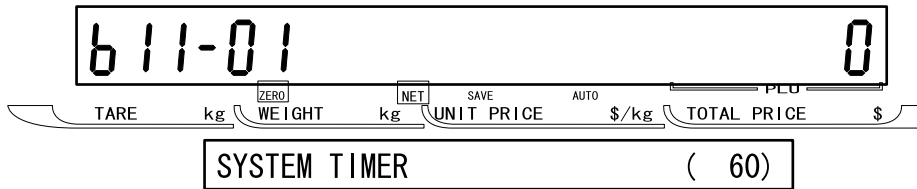

- A function to maintain called data only for a specified time period when there no scale operation is performed in normal mode.
- Time period: 10 to 1,000 seconds (Default: 60 seconds, 1,000 seconds: Not used)

## 4.15 Password Setup

### ■ Password setting menu

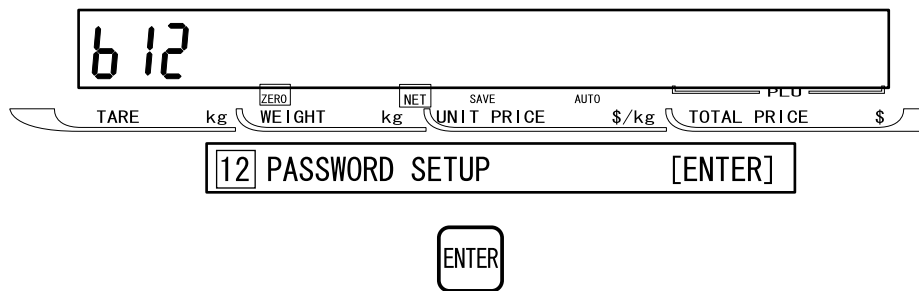

### ■ PASSWORD

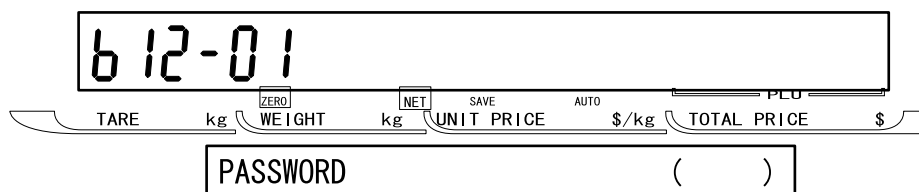

- Enter the set password when it is set in B12-01 menu.  
It is not possible to enter B12-03, B12-04, or B12-05 menu unless the password is not input.

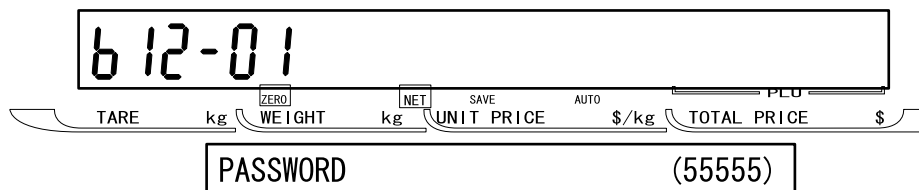

- Password input  
Example: Password "5555" Enter " 5555 " and press the ENTER key.

### ■ REGISTRATION

Input a password (4 digits) for Registration Mode.

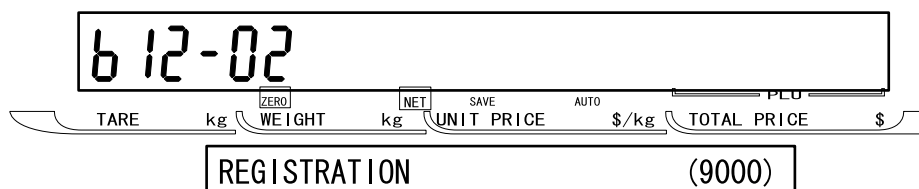

■TOTAL

Input a password (4 digits) for Total Mode.

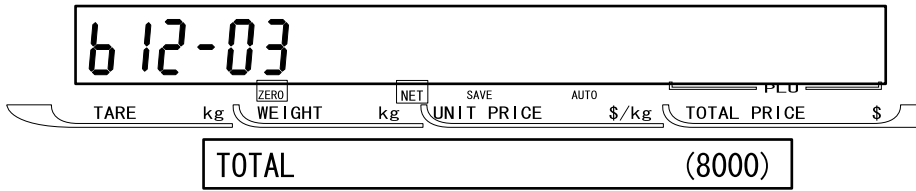

■SUBTRACTION

Input a password (4 digits) for Subtraction Mode.

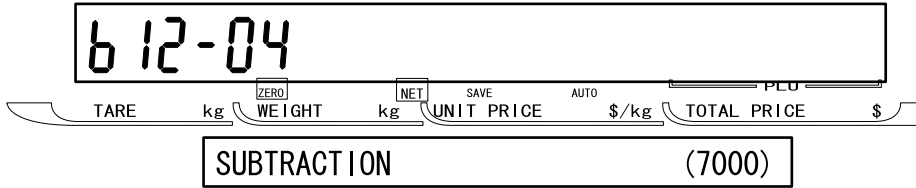

■SETUP

Input a password (4 digits) for Setup Mode.

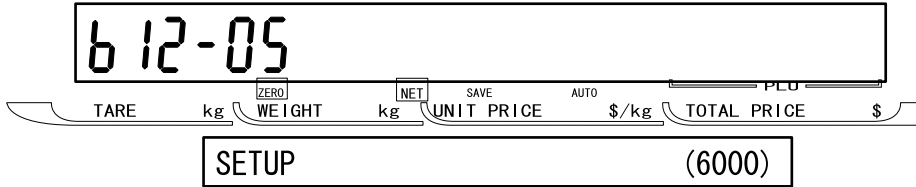

■TARE PASSWORD

Input a tare password (4 digits).

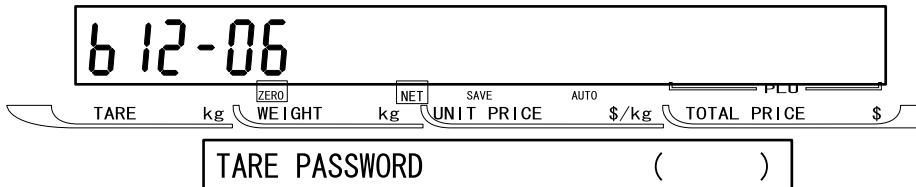

# CHAPTER 5 ELECTRICITY COMPOSITION

■Block wiring diagram “P-950A”

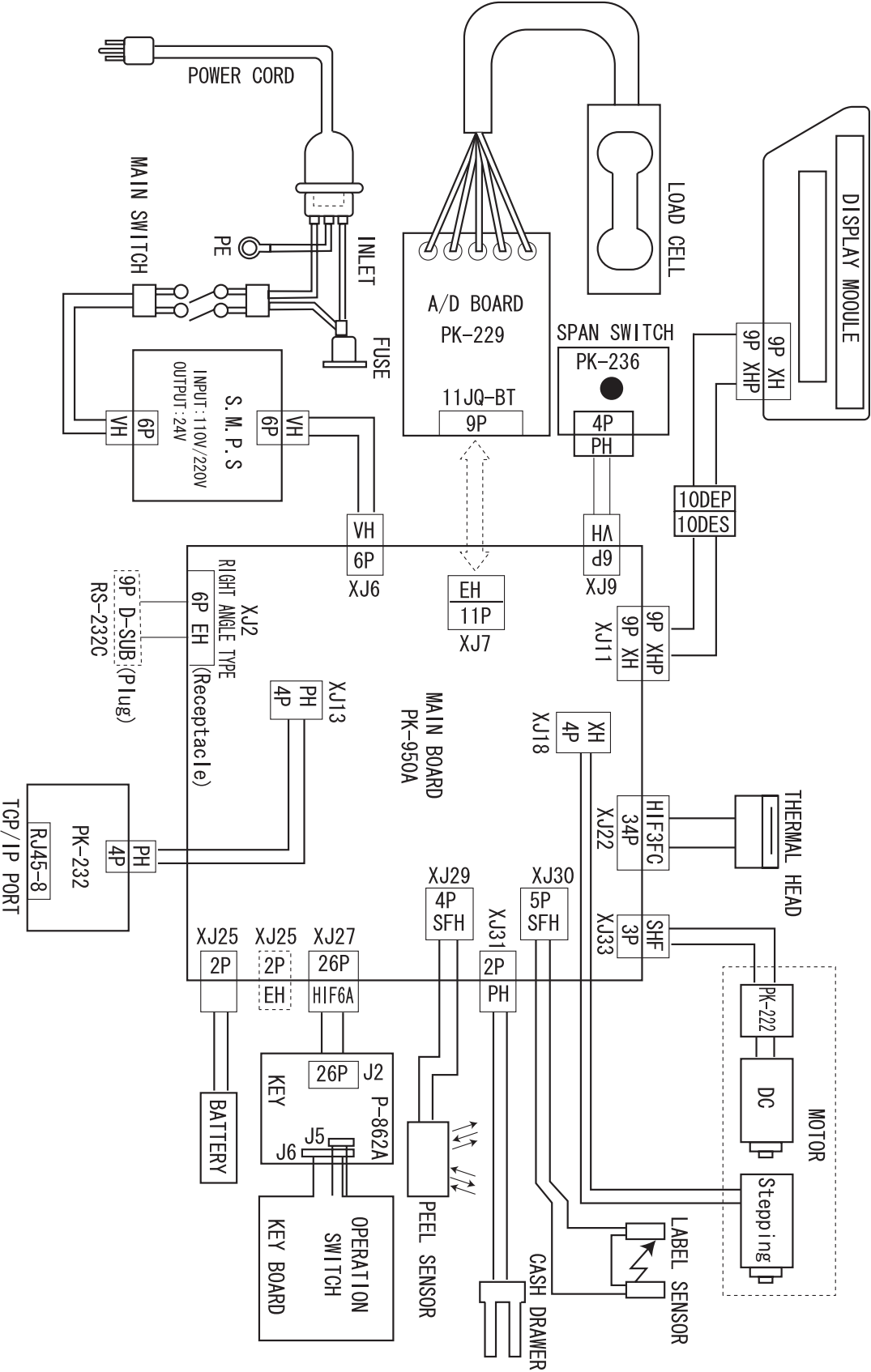



■Main Board [P-950A]

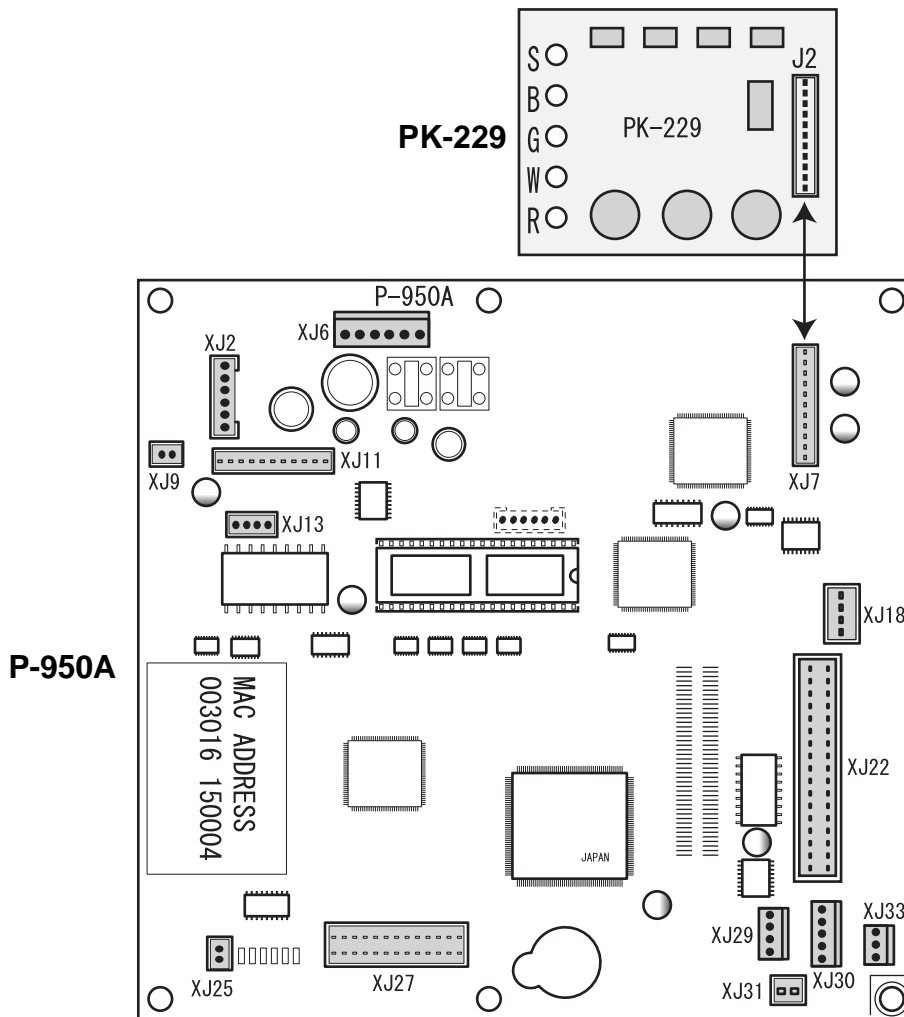

### ■AC-4000 (B/E) Main Unit (PK-950A) Connector Signal Name

#### XJ2: 9P D-SUB (Receptacle Plug), RS232C

No	Signal Name	No	Signal Name
1	RXD	4	SG
2	TXD	5	RTS
3	DTR	6	CTS

#### XJ6: B6P-VH, DC Power Supply

No	Signal Name	No	Signal Name
1	24V	4	GND
2	24V	5	GND
3	24V	6	GND

#### XJ7: B11B-XH -A, A/D Board

No	Signal Name	No	Signal Name
1	DF XIN	7	CAL
2	XIN	8	DRDY
3	SDATA	9	GND
4	SCLK	10	VH(+12V)
5	CS	11	RES
6	CONV		

#### XJ9: B2B-XH, -A Span Switch (PK-236)

No	Signal Name	No	Signal Name
1	SW	2	GND

#### XJ11: B9B-XH-A VFD I/F, (Display Module)

No	Signal Name	No	Signal Name
1	+5V	6	DATA #
2	GND	7	FG
3	+24V	8	SG
4	VH GND	9	RES
5	DATA		

#### XJ13: B4B-PH K-S, TCP/IP Port

No	Signal Name	No	Signal Name
1	TX+	3	RX+
2	TX-	4	RX-

**XJ18: B4B-XH -A, Step-motor**

No	Signal Name	No	Signal Name
1	A	3	!A
2	B	4	!B

**XJ22: HIF3FC-30PA-2.5DSA**

No	Signal Name	No	Signal Name
1	GND	16	NO CONNECT
2	VH (+24V)	17	NO CONNECT
3	GND	18	DATA OUT
4	VH (+24V)	19	TH1
5	GND	20	TH2
6	VH (+24V)	21	RIO0
7	GND	22	RIO1
8	VH (+24V)	23	RIO2
9	GND	24	NO CONNECT
10	VH (+24V)	25	ENABLE 1
11	GND	26	NO CONNECT
12	VCC (+5V)	27	NO CONNECT
13	DATA Ain	28	ENABLE 2
14	CLOCK	29	NO CONNECT
15	LATCH	30	NO CONNECT

**XJ25: 5264-02 (MOLEX), Battery +3/2.000mAH**

No	Signal Name	No	Signal Name
1	BAT (+3V)		
2	GND		

**XJ27: HIF 6A-26PA-1.27DSA, Key Board**

No	Signal Name	No	Signal Name
A1	KS0	A5	KD0
B1	KS1	B5	KD1
A2	KS2	A6	KD2
B2	KS3	B6	KD3
A3	KS4	A7	KD4
B3	KS5	B7	KD5
A4	KS6	A8	KD6
B4	KS7	B8	KD7
		A9	KD8
		B9	KD9
		A10	KD10
		B10	KD11
		A11	KD12
		B11	KD13
		A12	KD14
		B12	KD15
		A13	BZR
		B13	VCC

**XJ29: B4P-SHF -1AA, Peel Sensor**

No	Signal Name	No	Signal Name
1	NO CONNECT		VCC
2	GND		OUTPUT

**XJ30: B5P-SHF -1AA, Label Sensor**

No	Signal Name	No	Signal Name
1	VCC	4	OUTPUT
2	VCC (+5V, 23mA)	5	NO CONNECT
3	GND		

**XJ31 :B2B-PH -K-S, Drawer I/F**

No	Signal Name	No	Signal Name
1	SIGNAL OUT (+24V)		
2	GND		

**XJ33: B3P-SHF -1AA, DC Motor**

No	Signal Name	No	Signal Name
1	SIGNAL OUT (+24V)	3	NO CONNECT
2	GND	4	

**■ASTRA -XT Main Unit (P950A) Jumper Set**

- JP1000 - CONNECTION: EPROM Boot
- NO CONNECT: Flash Memory Boot

■PK229 (A/D board)

- The PK229 (A/D board) is fixed by the two spacers on the P-950 (Main board), and Five leads of the Load Cell cable are soldered to the PK229 (A/D board).

*Note: The load cell output cable and the A/D board (PK-229) are soldered.  
Confirm not to make a mistake in wiring when installed.*

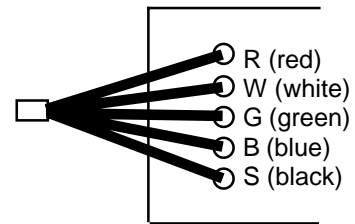
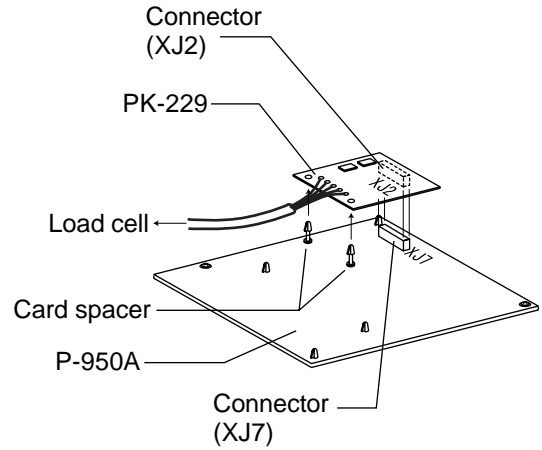

■LITHIUM BATTERY

- The battery connector is connected with the P-950A (XJ25).  
To remove the battery, pull out the connector.
- The battery is fixed by a nylon clamping.  
To remove the battery, remove the screw (M4 x 10).

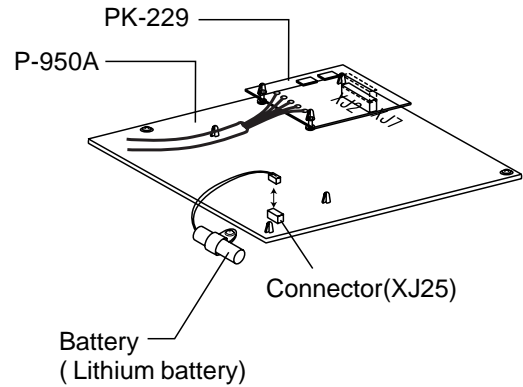

■Power Unit (LSF100 - 24S)

External view

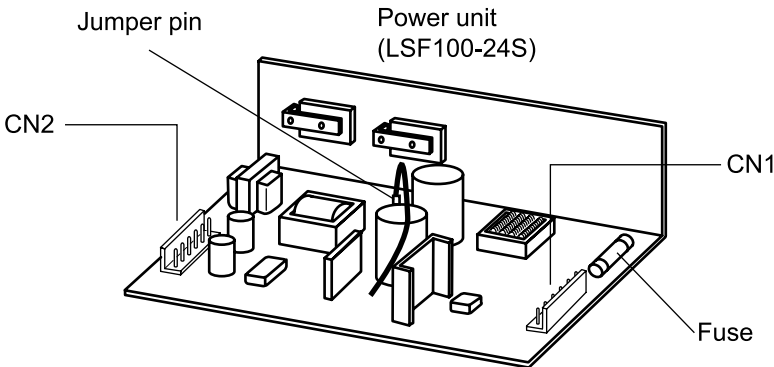

Block diagram

Changing the Power Supply Unit

Voltage	110V 89-2760-03 LSF100-24S
	220V 89-2771-09 LSF100-24S

110V and 220V can be changed by switching over Jumper Pin on LSF100-24V

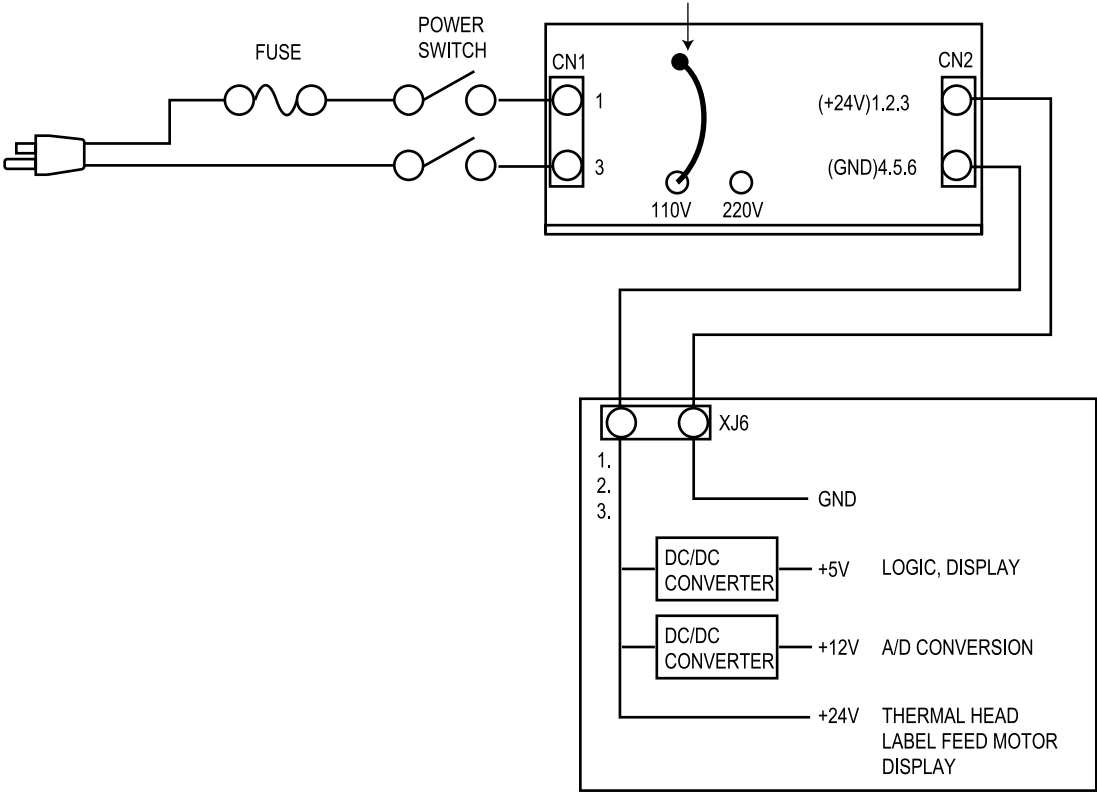

**■PK-232 (TCP/IP)**

**Connecting LAN cable**

When connecting the LAN cable, securely insert the connector into the LAN port until it clicks.

**Cable connection method**

- Use a crossing cable for connecting the PC and the AC-4000.
- Use a straight cable for connecting the PC, Hub, and the AC-4000.

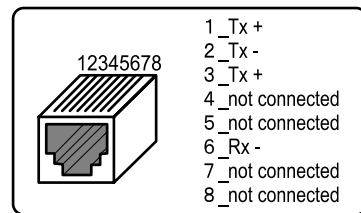
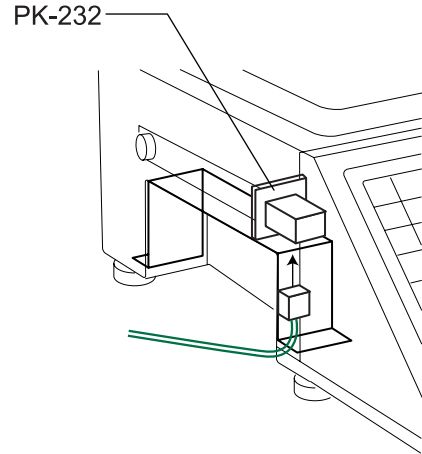

**Cable connection method**

- Use a crossing cable for connecting the PC and the AC-4000.
- Use a straight cable for connecting the PC, Hub, and the AC-4000.

P-950 supports 10M bit Ethernet through an RJ45 connector.

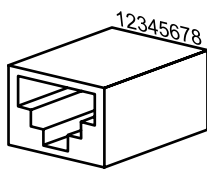

**Straight cable**

- |   |                |
|---|----------------|
| 1 | _Tx+           |
| 2 | _Tx-           |
| 3 | _Rx+           |
| 4 | _not connected |
| 5 | _not connected |
| 6 | _Rx-           |
| 7 | _not connected |
| 8 | _not connected |

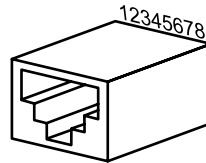

**Crossing cable**

- |   |                |
|---|----------------|
| 1 | _Rx+           |
| 2 | _Rx-           |
| 3 | _Tx+           |
| 4 | _not connected |
| 5 | _not connected |
| 6 | _Tx-           |
| 7 | _not connected |
| 8 | _not connected |

■PK-236 (SPAN SWITCH)

Changed data is cleared when completing this mode unless it is memorized in “E2ROM” by pushing the “Memory Button”.

*Note: An authorization test may be required if “A/D DATA” is changed according to the measurement regulations where the machine is used.*

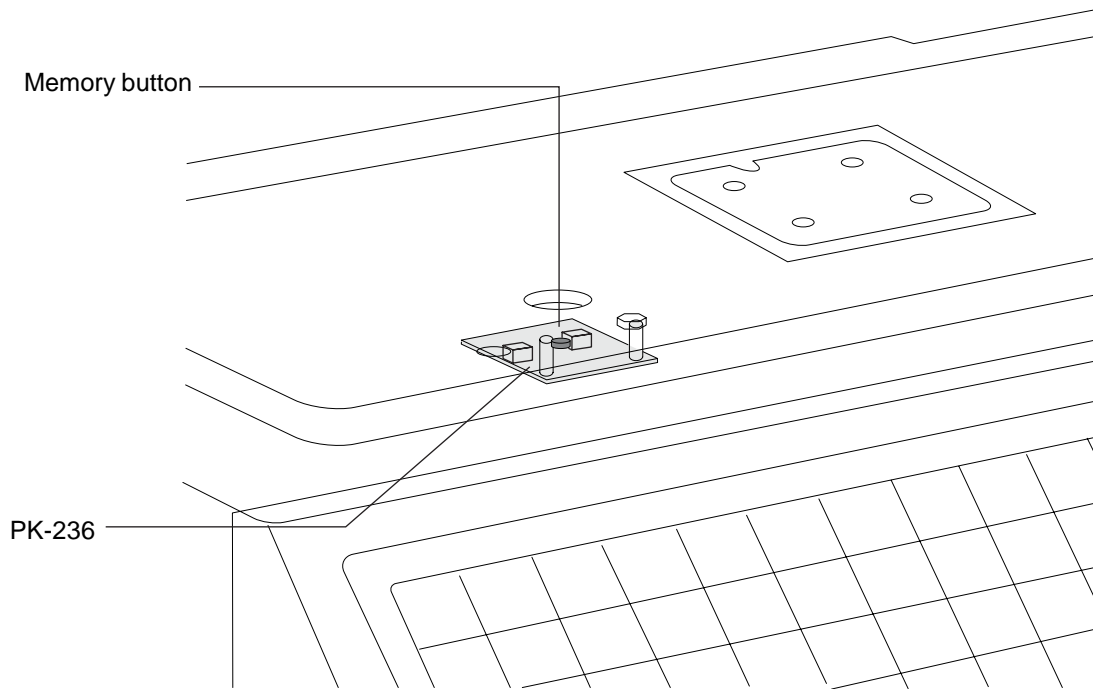

*Note: The operation procedure is described in 3.3 of Chapter 3.*



■P-862 (KEYBOARD)

- The P-862 (Keyboard) is mounted in the operation panel located in front of the main body.
- Two harnesses are connected from the key sheet to the P-862 (Keyboard).

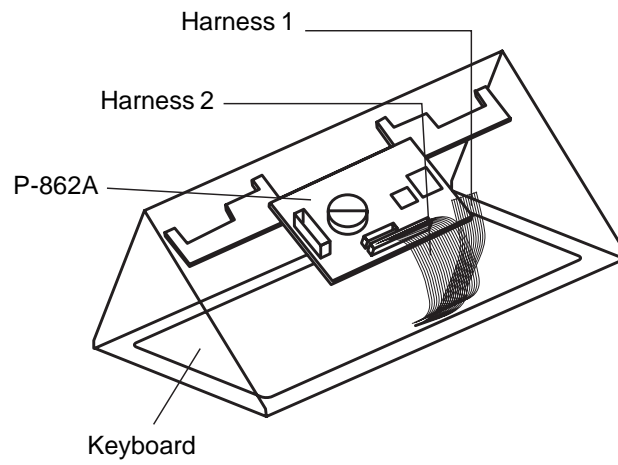

# CHAPTER 6 TROUBLESHOOTING

## 6.1 Error List

### ■Error no.

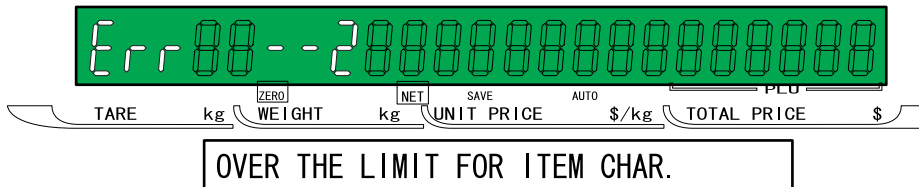

**Error 3:** When POP MESSAGE exceeds the limit number of characters.

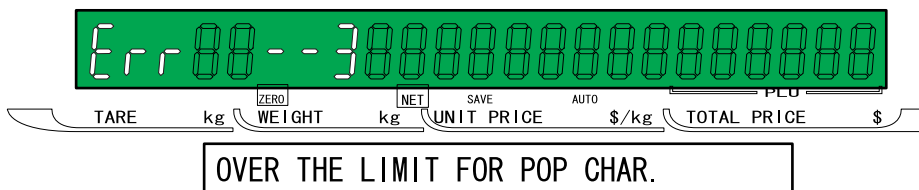

*Note:* Pressing the CLR key returns to normal mode.

**Error 4:** When EXTRA MESSAGE exceeds the limit number of characters.

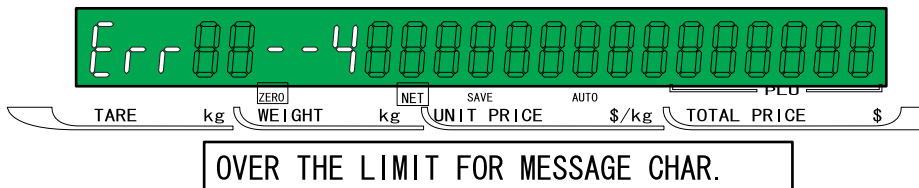

*Note:* Pressing the CLR key returns to normal mode.

**Error 7:** When STORE NAME/ADDRESS exceeds the limit number of characters.

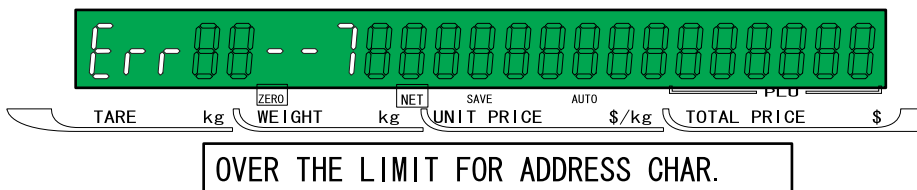

*Note:* Pressing the CLR key returns to normal mode.

**Error 8:** When a label paper runs out.

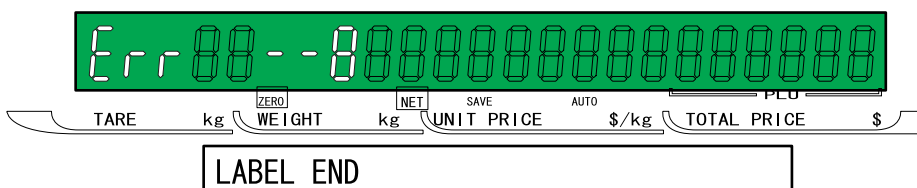

*Note:* Pressing the CLR key returns to normal mode.

**Error 9:** When a label size is not suitable.

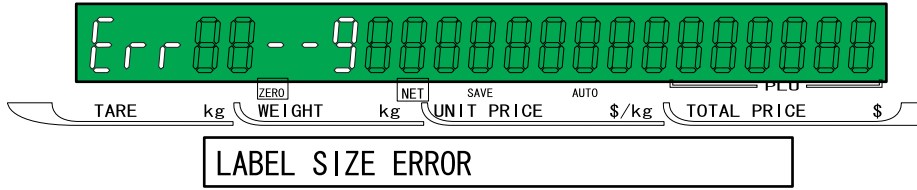

*Note: Pressing the CLR key returns to normal mode.*

**Error 10:** When an error occurs in a discount calculation.

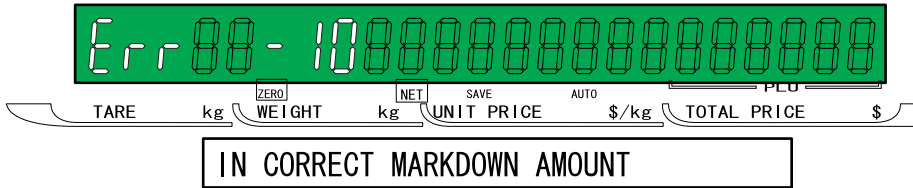

*Note: Pressing the CLR key returns to normal mode.*

**Error 11:** When EXTRA MESSAGE 2 exceeds the limit number of characters.

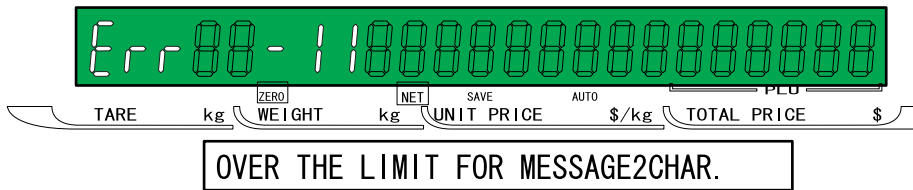

*Note: Pressing the CLR key returns to normal mode.*

**Error 12:** When EXTRA MESSAGE 3 exceeds the limit number of characters.

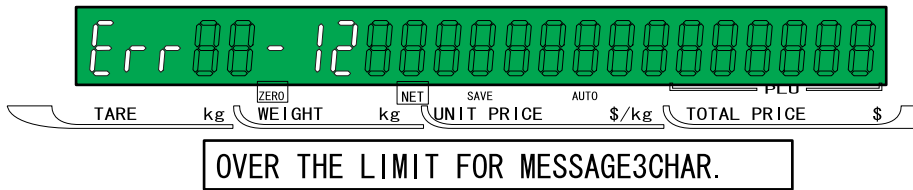

*Note: Pressing the CLR key returns to normal mode.*

**Error 13:** When COUPON exceeds the limit number of characters.

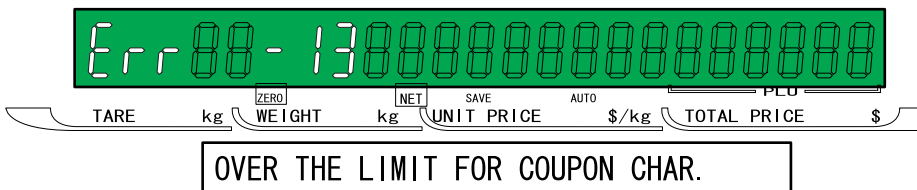

*Note: Pressing the CLR key returns to normal mode.*

**Error 16:** When actual memory overflows.

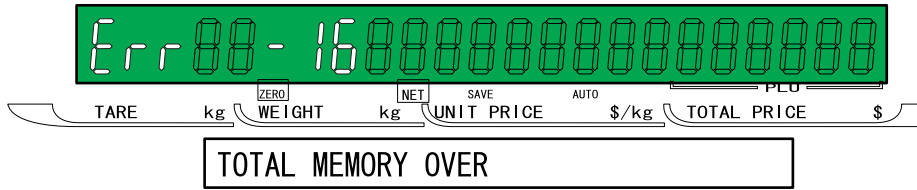

*Note: Pressing the CLR key returns to normal mode.*

**Error 21:** Thermal head fault error.

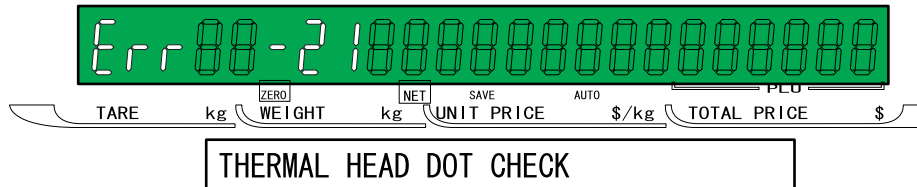

*Note: Pressing the CLR key returns to normal mode.*

**Error 40:** When an error occurs in internal memory.

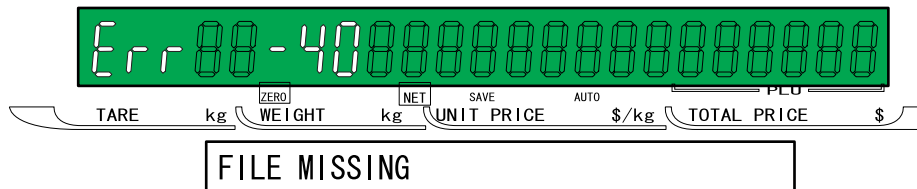

*Note: Pressing the CLR key returns to normal mode.*

Weight over error: Blank

Weight under error: -----

Over error: Remove a thing placed on the weigh platter.

### ■Symptom, cause, and measures

Symptom	Cause	Measures
Power is not applied.	<ol style="list-style-type: none"> <li>1. Power plug has come off.</li> <li>2. Fuse burns.</li> <li>3. Defect of main board (PK-950)</li> <li>4. Defect of power supply unit (LSF100-24S)</li> <li>5. Defect of power switch</li> </ol>	<ol style="list-style-type: none"> <li>1. Insert the power plug.</li> <li>2. Replace with a new fuse.</li> <li>3. Replace with a new PK-950.</li> <li>4. Replace with a new LSF100-24S.</li> <li>5. Replace with a new power switch.</li> </ol>
Turning on power enters test mode.	<ol style="list-style-type: none"> <li>1. Defect of PK-950</li> <li>2. Defect of keyboard switch</li> </ol>	<ol style="list-style-type: none"> <li>1. Replace with a new PK-950.</li> <li>2. Replace with a new keyboard switch.</li> </ol>
No further process after display check	<ol style="list-style-type: none"> <li>1. Defect of load cell</li> <li>2. Vibration from the outside.</li> <li>3. Defect of A/D board (PK-229)</li> <li>4. Defect of main board (PK-950)</li> <li>5. Defect of power supply unit (LSF100-24S)</li> </ol>	<ol style="list-style-type: none"> <li>1. Loading cell adjustment and exchange</li> <li>2. Confirmation and transfer of installation location</li> <li>3. Replace with a new PK-229.</li> <li>4. Replace with a new PK-950.</li> <li>5. Replace with a new LSF100-24S.</li> </ol>
Weighing margin occurs. (Flickering)	<ol style="list-style-type: none"> <li>1. Four corners limit screw comes in contact.</li> <li>2. Foreign obstacle under the load cell.</li> <li>3. Defect of A/D board (PK-229)</li> <li>4. Defect of load cell</li> <li>5. Defect of main board (PK-950)</li> </ol>	<ol style="list-style-type: none"> <li>1. The four corners limit screw is adjusted</li> <li>2. Removal of foreign body</li> <li>3. Replace with a new PK-229.</li> <li>4. Adjustment and exchange of load cell</li> <li>5. Replace with a new PK-950.</li> </ol>
Specific segment does not light.	<ol style="list-style-type: none"> <li>1. The connection is abnormal of the connector.</li> <li>2. Defect of main board (PK-950)</li> <li>3. Defect of display board</li> </ol>	<ol style="list-style-type: none"> <li>1. The connector connection is confirmed.</li> <li>2. Replace with a new PK-950.</li> <li>3. Replace with a new display board.</li> </ol>
A key is not entered.	<ol style="list-style-type: none"> <li>1. Defect of key sheet</li> <li>2. Improper connection of connector</li> </ol>	<ol style="list-style-type: none"> <li>1. Replace with a new key sheet.</li> <li>2. The connector connection is confirmed.</li> </ol>
Registered data changes.	<ol style="list-style-type: none"> <li>1. Defect of battery</li> <li>2. Defect of main board (PK-950)</li> <li>3. Noise from the outside or influence of static electricity</li> </ol>	<ol style="list-style-type: none"> <li>1. Replace with a new battery.</li> <li>2. Replace with a new PK-950.</li> <li>3. The installation location is confirmed and transferred.</li> </ol>
All the display goes off.	<ol style="list-style-type: none"> <li>1. Voltage fluctuation</li> <li>2. Defect of power supply unit (LSF100-24S)</li> <li>3. Defect of display board</li> <li>4. Defect of main board (PK-950)</li> </ol>	<ol style="list-style-type: none"> <li>1. The power-supply voltage is confirmed.</li> <li>2. Replace with a new LSF100-24S.</li> <li>3. Replace with a new display board.</li> <li>4. Replace with a new PK-950.</li> </ol>
Print is not carried out.	<ol style="list-style-type: none"> <li>1. Abnormality of thermal head cable</li> <li>2. Defect of power supply unit (LSF100-24S)</li> <li>3. Defect of thermal head</li> <li>4. Defect of main board (PK-950)</li> </ol>	<ol style="list-style-type: none"> <li>1. Confirmation of cable</li> <li>2. Head sign acceptable voltage confirmation LSF100-24S exchange</li> <li>3. Thermal head adjustment and exchange</li> <li>4. Replace with a new PK-950.</li> </ol>

# CHAPTER 7 PARTS REPLACEMENT

## 7.1 Detaching Each Part (Unit)

### ■ Detach the weigh platter

1. Remove the power plug from the main power outlet.
2. Lift the weigh platter horizontally.

*Note: The weigh platter is fixed by the 4 pins under the platter inserted in a center of each rubber on the platter holder.*

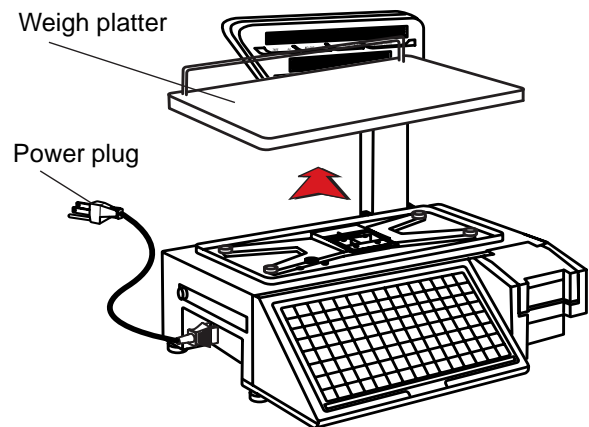

### ■ Detaching the platter holder

1. Detaching the platter holder by removing the 4 screws (M4 x 12).

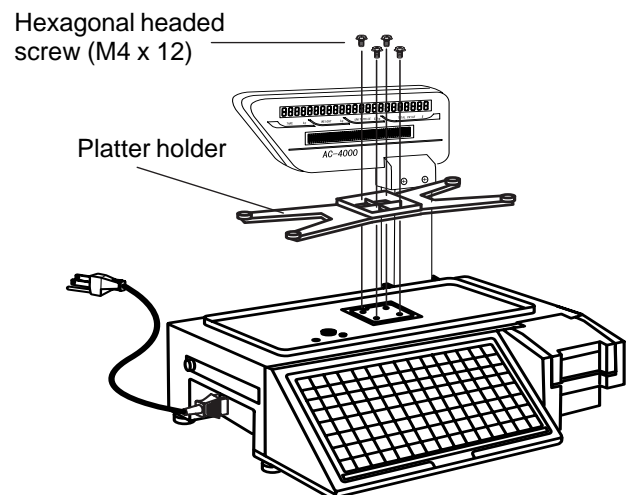

### ■ Detaching the display unit.

1. Remove the 2 screws (B).
2. Lift up the stand to remove.
3. Pull out the connector.
4. Remove the 4 screws (A) to detach the display.

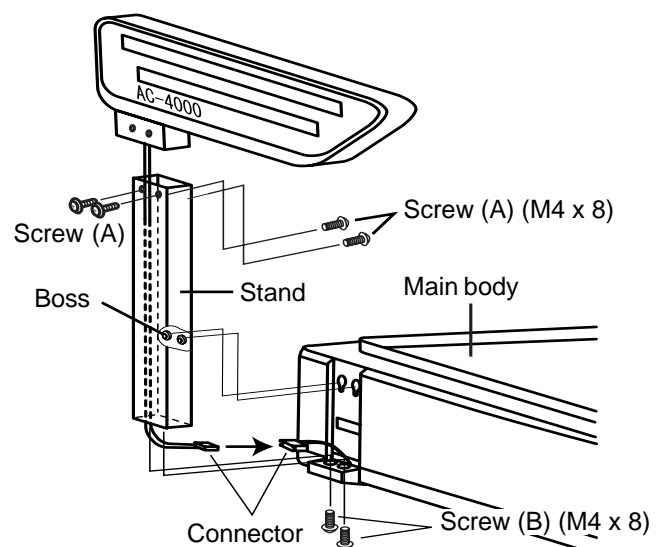

■ Detaching the front cover (key sheet)

1. Cut the seal wire.
2. Remove the 2 seal screws.

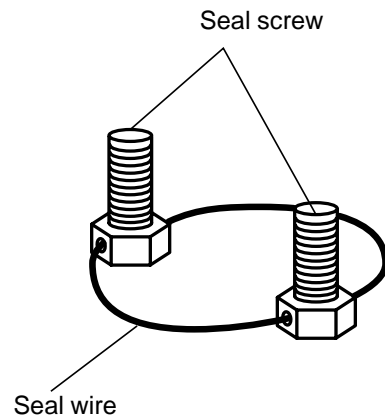

3. Remove the 2 screws (M4 x 12) of the operation panel (front cover).
4. Remove the harness connected with P-950A from P-862A on the back of the front cover (operation panel).

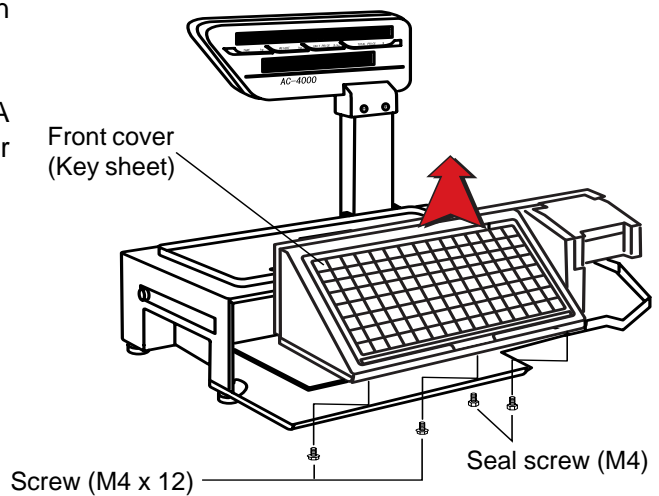

5. Pull out the connector of the P-862A.
6. Remove the front cover.

*Note 1: The base seal wire is used only for a country requiring a base seal. For other countries, remove the 4 screws (M4 x 12) only.*  
*Note 2: If the base seal wire is cut, it is necessary to seal the base again for an authorization test. Do not cut the base seal wire except a case when necessary.*

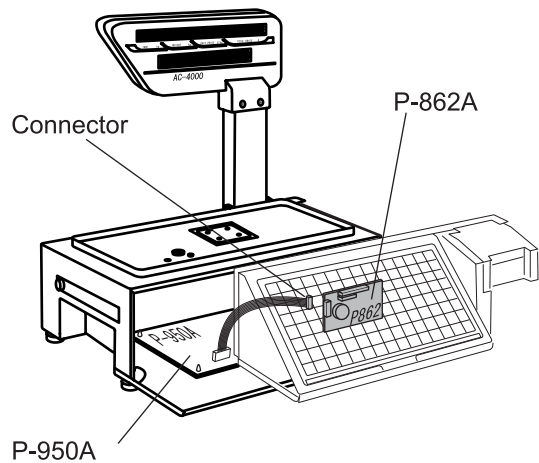

**■Detaching the top case**

1. Cut the seal wire.
2. Remove the seal screw.
3. Remove the 4 screws (M4 x 12) located on the top case.

- Note 1: The top case seal wire is used only for a country where the top case seal is required.*
- 2: It is necessary to receive authorization test and seal the top case again if the top case seal wire is cut.*
- 3. Do not cut the top case seal wire except a case when necessary.*

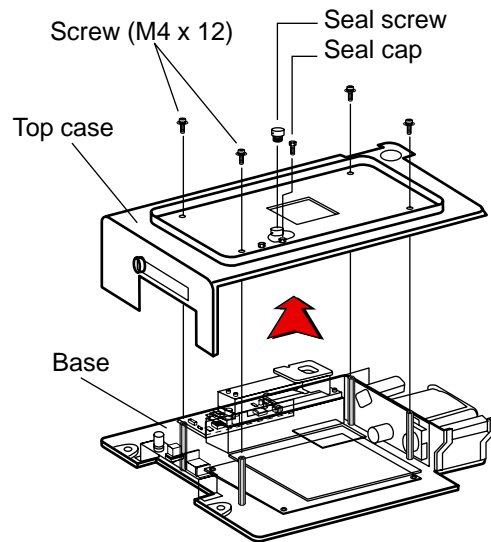
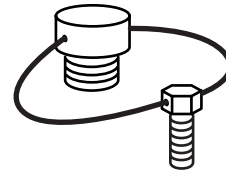



## 7.2 Detaching Internal Parts

This work must be carried out after finishing preceding section 7.1.

### ■Detaching the keyboard relay board (P-862A)

1. Pull out the harness of the front key sheet from the connector on the P-862A.
2. Remove the 4 M4 screws fixing the key board (P-862A).

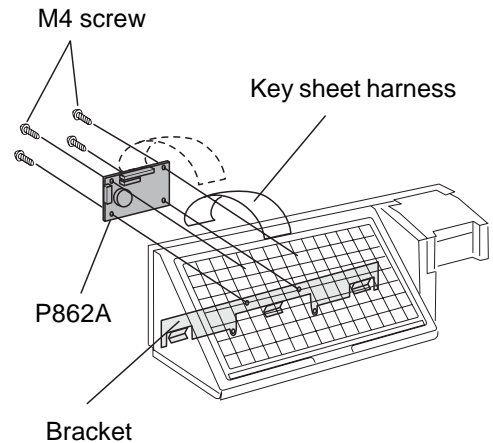

3. Pull out harnesses 1 and 2 of the key sheet from the P-862A.

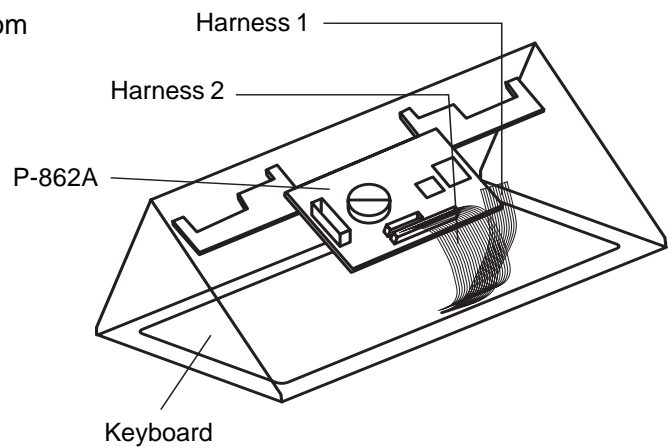

### ■Detaching the key sheet

1. Peel off the sheet from the edge of the key sheet.

*Note: Care must be paid so as not to damage the main body when peeling off the key sheet.*

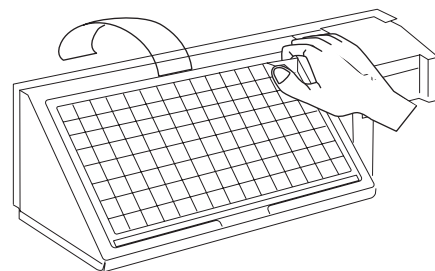

**■Detaching the power supply**

1. Pull out the "CN1" and "CN2" connectors.
2. Remove the 2 screws (M4 x 12) on the bottom.

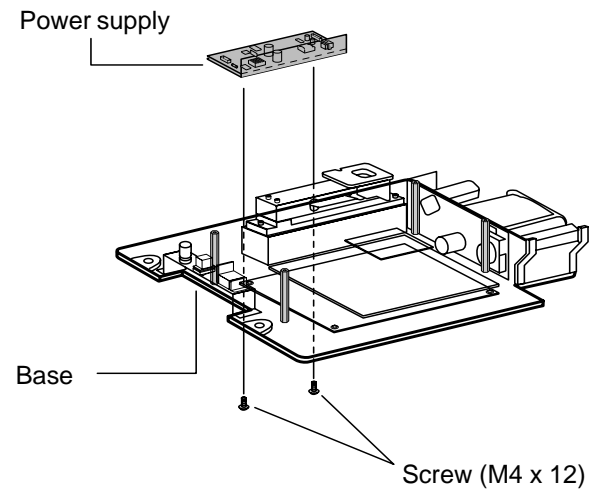
**■Detaching the span switch (PK-236)**

1. Pull out the connector of the PK-236.
2. Remove the 2 screws (M4 x 8).

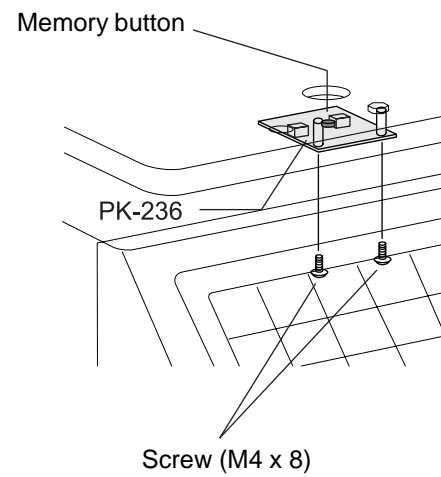

■ Detaching the load cell

1. Remove the leads soldered to the PK-229.
2. Remove the 3 screws (M5 x 5) fixing the load cell.

- Note 1: Ensure not to mistake wirings when installing the load cell output cable.*
- 2: Check the four corner limit after exchanging the load cell.
  - 3: Perform span adjustment after exchanging the load cell.

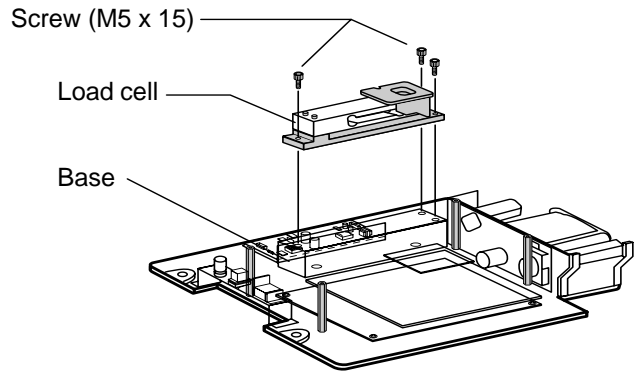

■ 4-corner limit adjustment

- For the overload from the outside to protect the load cell, this machine has installed the 4 limit screws on the platter holder.

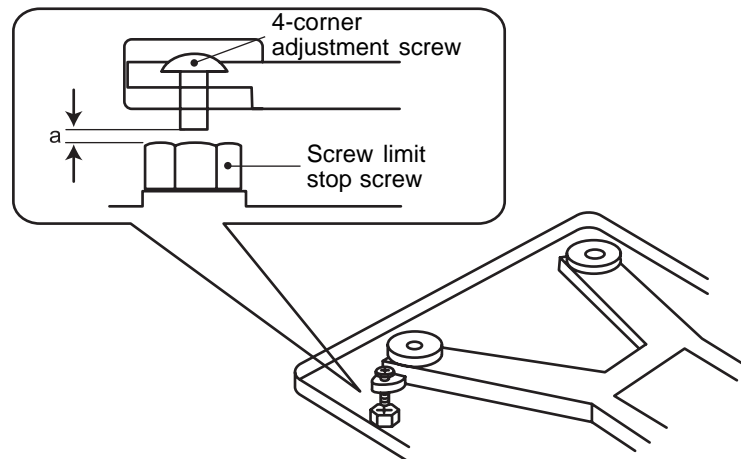

- Adjust the 4 spaces (a) on the platter holder at four corners as shown in the figure below.



■ Detaching the PK-229 (A/D board)

1. Pull out the PK-229 from card spacers.
2. Pull out the PK-229 (XJ2) and the P-950A (XJ7) connectors.
3. Remove soldering of the load cell output cable.

*Note 1: Perform span adjustment after the PK-229 is exchanged.*

*2: Check wirings when installing the load cell output cable.*

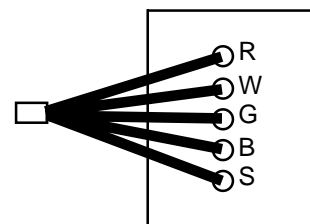
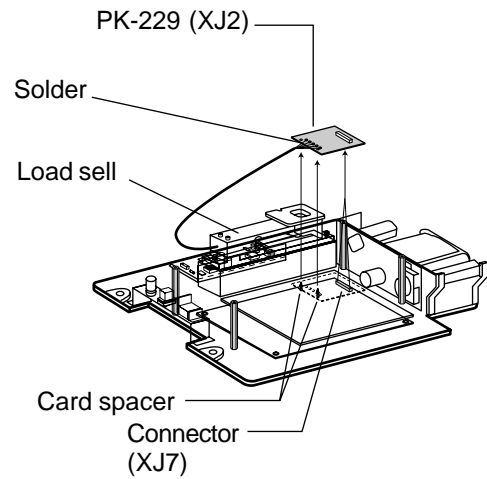

■ Detaching the PK-232 (TCP/IP)

1. Remove the two screws (M4 x 6).

*Note: Pull out the connector when LAN cable is connected.*

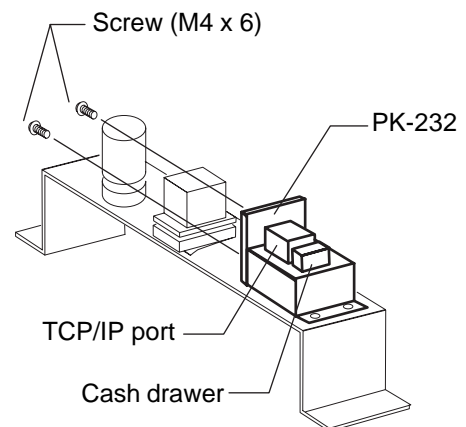

■ Detaching the PK-950A (Main board)

1. Pull out all the harnesses connected with the main board.
2. Remove the two screws (M4 x 6).
3. Remove the board from the 3 card spacers.

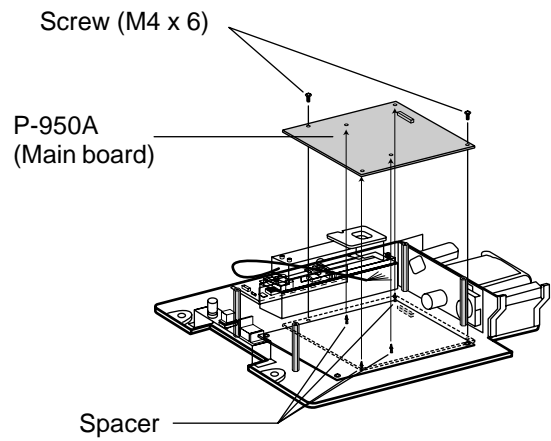

*Note 1: Ensure to tighten the 2 screws (M4 x 6) when assembled for establishing a ground.*  
*2: Refer to the previous page for detaching the PK-229 fixed on the P-950A with a connector.*

**■Detaching the stepping motor and the DC motor****Stepping motor**

A motor to feed a label to the label length.

1. Pull out the connector of the motor.
2. Remove the two screws (M3 x 6).

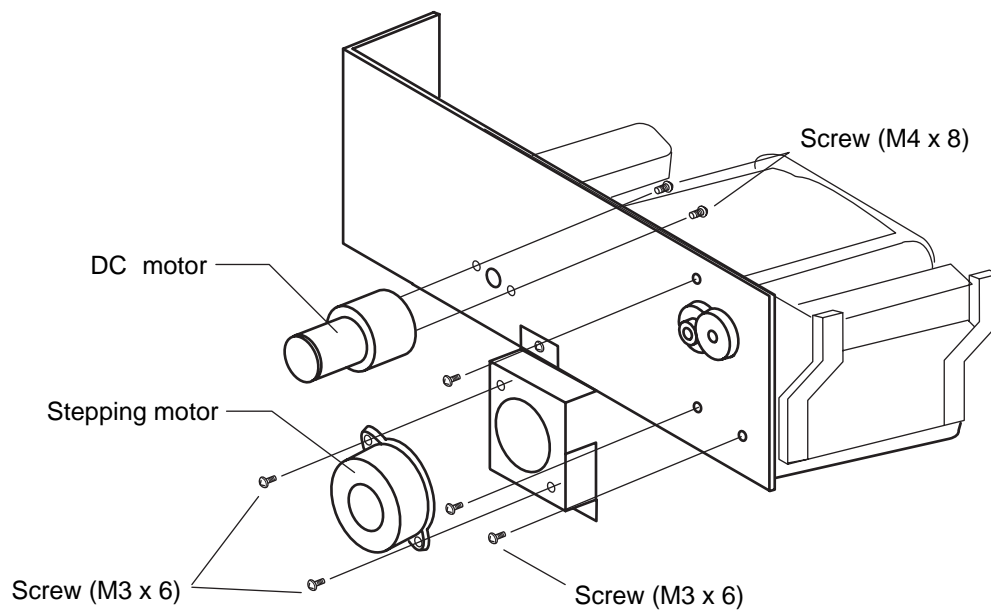
**DC motor**

A motor to wind up label backing paper.

1. Pull out the connector of the motor.
2. Remove the two screws (M4 x 8).

Printer parts composition

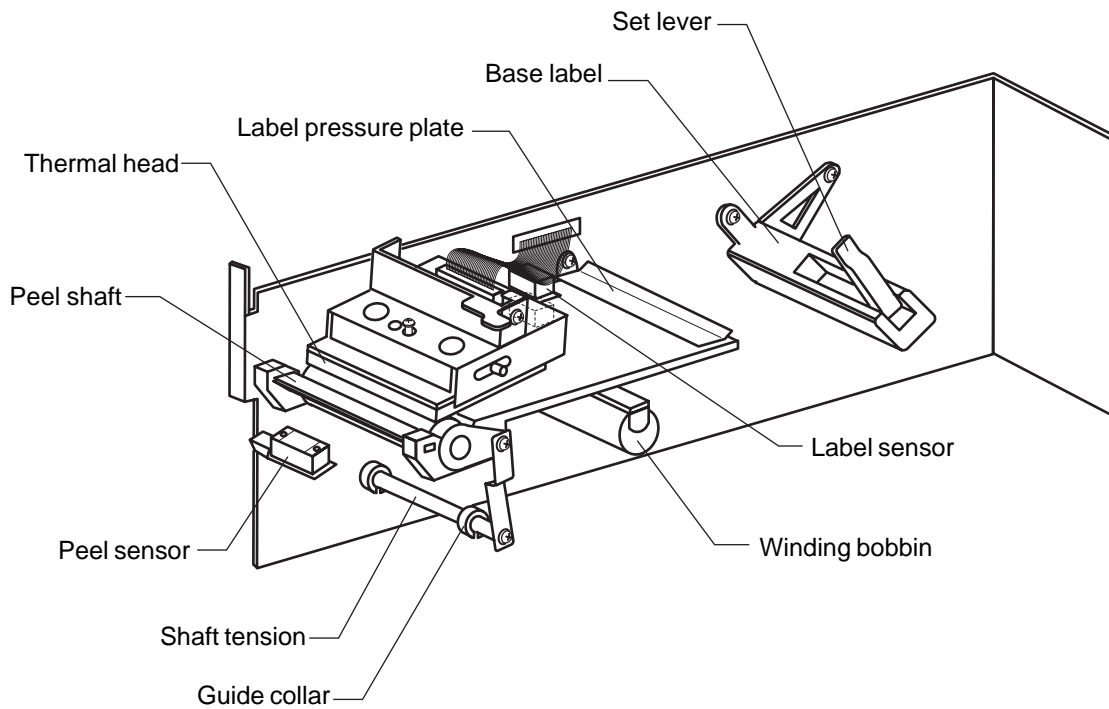

■ Detaching the label sensor

1. Pull out the connector of the P-950A (XJ18).
2. Remove the 2 screws (M4 x 8).

Note: Refer to "7.10 of Chapter 7" for installation place.

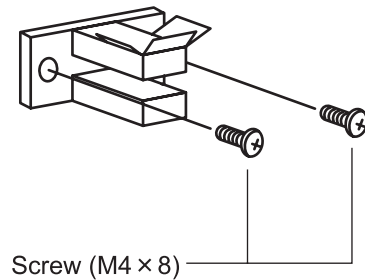

A = label + backing paper    B = Backing paper only

Note 1: "A" part (Label + mount) and "B" part (Backing paper only...Label gap) are detected by a sensor.

2: Refer to "3.13 of Chapter 3" for the adjustment procedure.

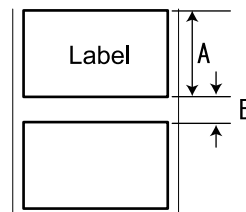

### ■Detaching the peel sensor

1. Pull out the connector of the P-950A (XJ29).
2. Remove the 2 screws (M3 x 18).

Note 1: Refer to "7.10 of Chapter 7" for installation place.

2: Refer to "3.17 of Chapter 3" for the adjustment method.

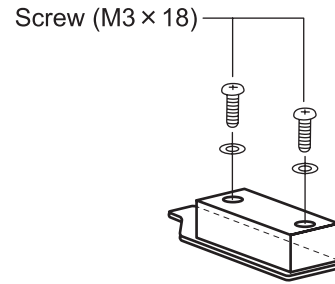

### ■Detaching the thermal head

1. Pull out the thermal (harness) connector.
2. Loosen the two screws (A), and put them into the state where they can come off.
3. Remove the screw (B). (It becomes easy to remove the thermal head.)
4. Put the thermal head into the state of opening quietly. (Care must be paid so as to drop neither the screw nor spring.)

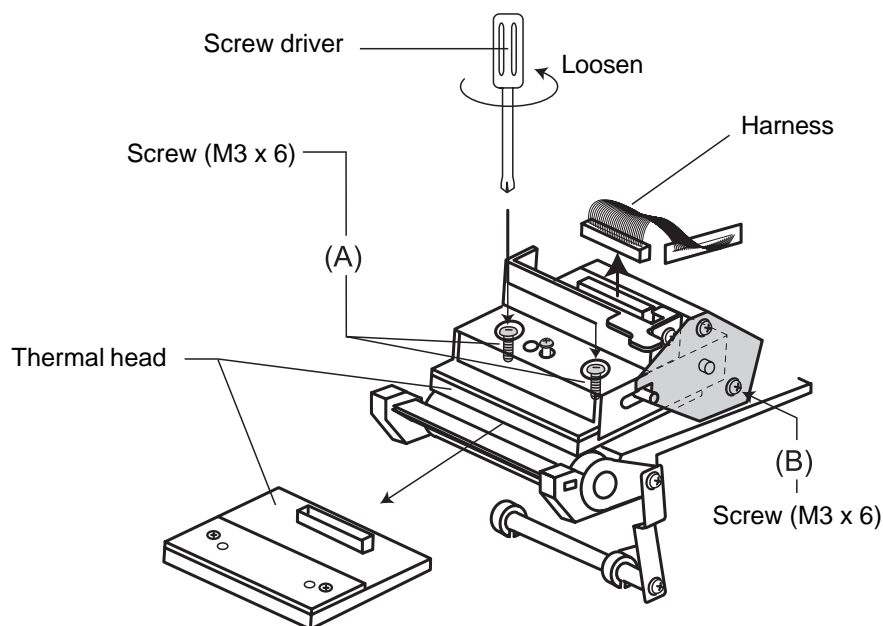



### Thermal head specifications

Model	LH3124I (Double-density thermal head) made by TDK
Total dot number	448 dots
Dot pitch	0.135mm
Head resistance	R=528 to 672 (automatic setting)
Power consumption	0.66W/dot
Applied voltage	24V

### Adjusting thermal head print conditions

- Loosen the two screws (M3 x 6) slightly, and move the thermal head back and forth.
- Adjust to match the top point of the print roller with the thermal head applied point.

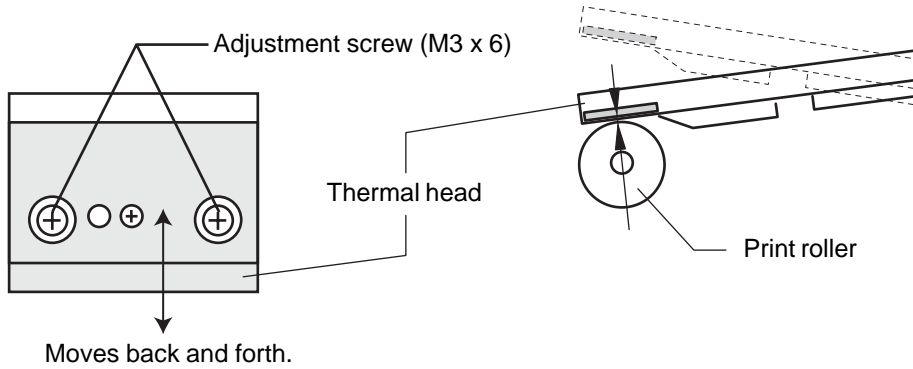

**■Detaching the display**

1. Pull out the 4 push rivets.
2. Pull to separate the operator and the customer displays apart.
3. Pull out the connector.

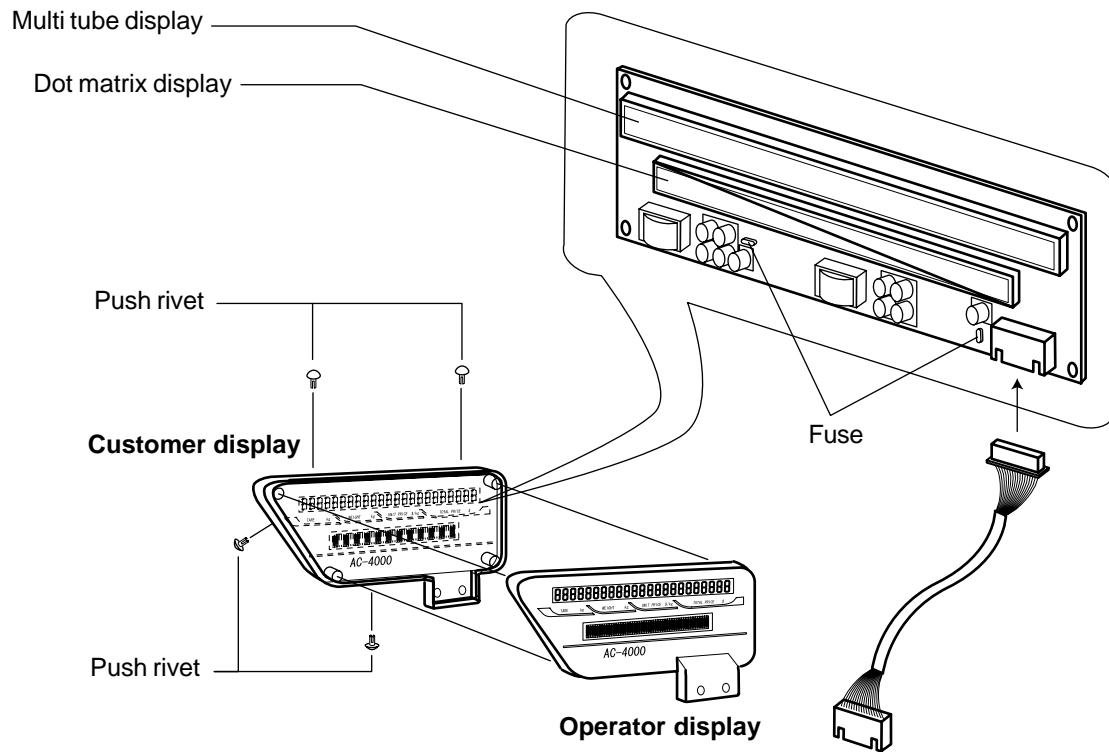

*Note: Refer to "7.1 of Chapter 7" for detaching the display from the main body.*

## 7.3 Periodical Replacement Parts

### ■Thermal head (LH3124I)

Replacement period: Label travel distance 40 to 60km (standard)

*Note: The label travel distance varies depending on the label material or thermal head cleaning conditions.*

### ■Display tube (Display board)

Life: Brightness must be 80% or more of the standard lower bound after lighting for 1,000 hours under the condition of all segments lighting by the standard ratings drive.

Life expectancy: 30,000 hours or more when using it by standard ratings drive.

(Life here is assumed to be a value that the average brightness becomes half of the standard lower bounds.)

### ■Print roller

Replacement period: 300km in the travel distance. (standard)

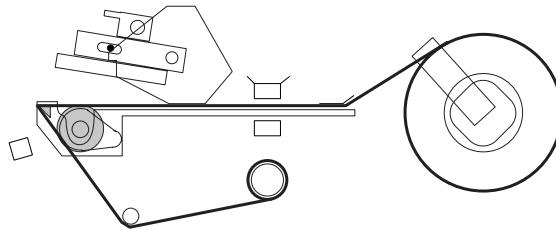

## 7.4 How to Pass Labels

A sticker "How to pass labels" is pasted to inner side of the side cover.

 **ISHIDA**



**ISHIDA CO., LTD.**

44 SANNO-CHO SHOGOIN SAKYO-KU

KYOTO, 606 JAPAN

PHONE: (075) 771-4141

FACSIMILE: (075) 751-1634

TELEX: 05422065 SCALES J

CABLE ADD: "SCALES"KYOTO

---