

# GET YOUR FREIGHT SPEND UNDER CONTROL



Reweighs, reclasses and unexpected chargebacks complicate transactions between shippers and less-than-truckload (LTL) carriers. Invoice corrections happen frequently because LTL carriers consistently correct weights and dimensions that are inaccurately declared on Bills of Lading. LTL carriers use of technology has made freight auditing a standard process, resulting in better cost control, load planning and resource management.

The introduction of Legal for Trade forklift scales and automatic dimensioning systems was a game changer for LTL carriers, enabling them to efficiently double-check measurements at the terminal and adjust the bill when needed. LTL carriers recover lost revenue and increase profits by implementing strong programs to audit a shipper's freight and confirm Bill of Lading (BOL) accuracy.

LTL carriers are embracing a digital transformation with the adaptation of a new industry-standard electronic Bill of Lading (eBOL). Automatic dimensioners will play a vital role in the transition to digital resources as they support transparency in the measurement processes, helping to build trust with the LTL carrier.

## HOW DIMENSIONERS BENEFIT SHIPPERS

When shippers use an automatic dimensioner, they experience fewer invoice corrections, which saves time and money. Shippers can also use a Transportation Management System (TMS) to provide

an eBOL with accurate data from a Legal for Trade dimensioner and scale save on freight rates. A TMS offers to the carrier data transparency before pickup to help with load planning.

Accurate weights and dimensions are essential to ensure your invoice will match the original carrier quote. Because LTL carriers also rely on Legal for Trade measurement systems, using freight dimensioning systems in your facility can help everyone ensure correct freight classification.

By choosing a dimensioning system that includes high-resolution cameras, you will have images of freight as it leaves your facility, documenting its condition and verifying it was properly packaged and wrapped. This will allow you to hold your LTL carriers accountable for any damage to your freight.

Rice Lake Weighing Systems developed iDimension® Flex Series automatic dimensioners to help shippers prevent invoice corrections. A Legal for Trade dimensioner and scale is the best way to safeguard against reweighs, reclasses and unexpected chargebacks from LTL carriers. The economical iDimension Flex is designed for shippers—it is affordable, easy to install and maintain, and has a full integration toolkit to connect with your network.

The iDimension Flex is designed to fit nearly any shipping environment. It can be installed as a free-standing unit or suspended from the ceiling and mounted over a scale, conveyor or pallet stretch wrapper. With the iDimension Flex, you

can easily organize your shipping department to weigh, wrap and dimension freight in one efficient step. The iDimension Flex accurately measures your outbound freight, simplifying eBOL processes and increasing the trust LTL carriers have in your measurements.

*iDimension Flex Series  
suspended above  
floor scale*

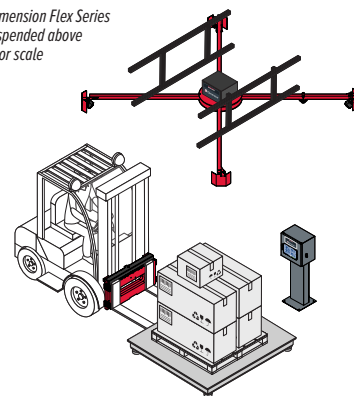

*iDimension Flex Series  
free-standing above  
conveyor*

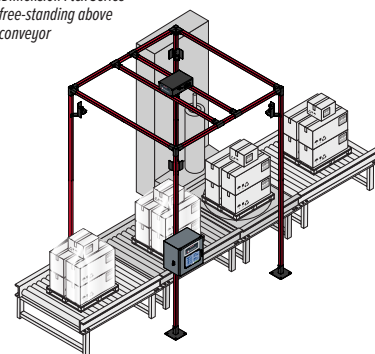

**RICE LAKE**  
WEIGHING SYSTEMS

HEADQUARTERS  
230 West Coleman Street  
Rice Lake, Wisconsin 54868 - USA  
Tel: (715) 234 9171 | Fax: (715) 234 6967  
[www.ricelake.com](http://www.ricelake.com)