

1280 Enterprise™ Series

Analog Output Cards

The Dual (PN 164686) and Single (PN 165366) Analog Output Cards provide either a 0–10 VDC or 0–20 mA (4–20 mA) output, proportional to the displayed gross or net weight.



Manuals and additional resources are available from the Rice Lake Weighing Systems website at www.ricelake.com

Warranty information can be found on the website at www.ricelake.com/warranties



WARNING



Always disconnect power before opening the indicator. Option card is not hot swappable.



IMPORTANT

Use a wrist strap to ground yourself and protect components from electrostatic discharge (ESD) when working inside the indicator enclosure.

Procedures requiring work inside the indicator must be performed by qualified service personnel only.

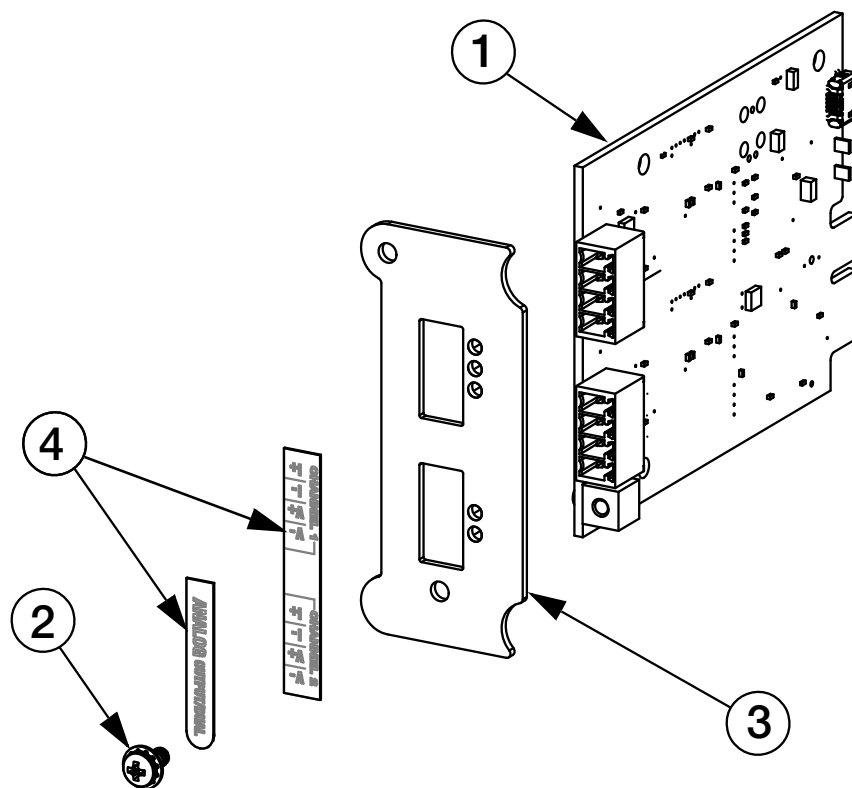

Figure 1. Dual Analog Output Card Kit

Item No.	Part No.	Description	Qty
1	162931	Board Assembly, 1280 Dual Com	1
	164704	Board Assembly, 1280 Single Com	
2	14822	Screw, Mach 4-40 NCx1/4	1
3	164679	Face Plate, Dual Option Card	1
	167201	Face Plate, Single Option Card	
4	167197	Label, Serial Opt 1280	1

Table 1. Analog Output Card Kit Parts List

The included parts kit contains items used for installation of the card. Items listed for stud grounding of the shields pertain to the panel mount enclosure. See the 1280 Technical Manual (PN 167659) for more information on shield grounding.

Part No.	Description	Qty
14621	Nut, Kep 6-32NC HEX (Used for Stud Grounding)	2/1
14822	Screw, Mach 4-40 NCx1/4 (Secures Card to Controller Assembly)	1
15130	Washer, Lock No. 6 Type A (Used for Stud Grounding)	2/1
153878	Conn, 4 Pos Screw Terminal (Interface Connector)	2/1
15631	Cable Tie, 3" Nylon (Secures Cable in Panel Mount Installation)	4
53075	Clamp, Ground Cable Shield (Used for Stud Grounding)	2/1

Table 2. Parts Kit (Dual Analog Output Card PN 164693/Single Analog Output Card PN 168816)

Use the following instructions to install and configure the analog output option card.

1. Open the indicator as instructed in the 1280 Technical Manual (PN 167659).
2. Remove a slot cover plate from the controller assembly to open a slot for the card.
3. Remove protective tape from pins J3 on the option card prior to installation. Make sure the pins are clean of sticky residue by carefully wiping with rubbing alcohol.
4. Align the card to the slot; the screw hole in the faceplate of the card should align with the screw hole on the controller assembly.
5. Slide the card into the top and bottom grooves of the slot. Push the card until it is securely seated in the back plane.
6. Secure with screw 4-40 NC x 1/4 (provided).
7. Make connections to the option card, see Figure 2.

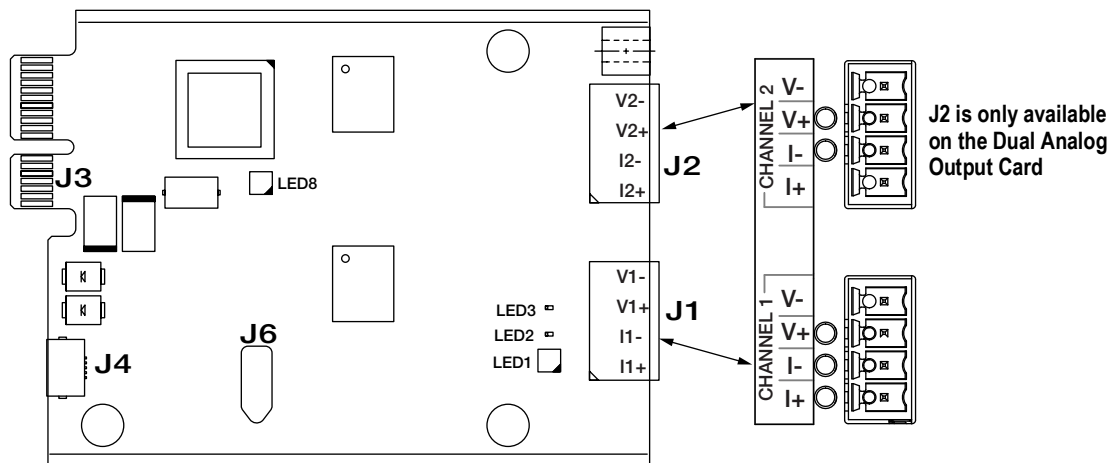

Figure 2. Analog Output Card (Dual Analog Output Card)

J1/J2	Channel 1/2
Pin 1	I+
Pin 2	I-
Pin 3	V+
Pin 4	V-

Table 3. Pin Assignments



Note The controller assembly slot that is selected for the option card installation determines which analog channels are available.



- Slot 1 = Output 1 or 2
- Slot 2 = Output 3 or 4
- Slot 3 = Output 5 or 6
- Slot 4 = Output 7 or 8
- Slot 5 = Output 9 or 10
- Slot 6 = Output 11 or 12

8. Use cable ties from the parts kit to secure loose cables inside the enclosure as needed. Ensure no excess or loose cable is left inside the enclosure.
9. Ground the shield cable using the ground washer in the metal cord grip, or use the grounding stud on the enclosure with cable clamp included in the parts kit, see the 1280 Technical Manual (PN 167659) for more information.
10. Tighten cord grips. Ensure cord grip nut is also tight.
11. Reassemble and power the indicator.



Note *The analog output must be calibrated after the indicator itself has been configured and calibrated.*

Analog Output Configuration

1. Within **Weigh Mode**, press . **Main Menu** displays.
2. Press  to access the **Configuration** menu.
3. To configure the analog output card, select  to enter the **Analog Output** menu.
 - Set **Output Mode** to 0–10 V, 4–20 mA or 0–20 mA
 - Set **Source** for the scale used as the source for the analog output
 - Set **Scale Mode** to track either gross or net weight from the scale
 - Set **Error Action** to specify how the analog output responds to system error conditions
 - Set **Minimum Value Tracked** to lowest weight value to be tracked by the analog output (a negative value can be entered)
 - Set **Maximum Value Tracked** to highest weight value to be tracked by the analog output (a negative value can be entered)

Analog Output Calibration

1. Connect a multimeter to connector J1 on the analog output card:
 - For voltage output, connect voltmeter leads to pins 3 and 4
 - For current output, connect ammeter leads to pins 1 and 2



Note *Access to the Configuration menu may be restricted. Refer to the 1280 Technical Manual for more information.*

2. Press **Calibrate** to enter the calibration wizard.
3. Adjust **Minimum** calibration: check voltage or current reading on multimeter. Use the numeric keypad to adjust the zero value up or down. The minimum calibration occurs at 0.5 V for a 0–10 V output and at 1 mA for a 0–20 mA output.
4. Adjust **Maximum** calibration. Use the numeric keypad to enter the value to be tracked.
5. Press  to return to weigh mode. The analog output function tracks gross or net weight.
6. For dual-channel cards, repeat calibration steps for the second (J2) connector.



Connection to PLC Analog Input Module

If the PLC analog input uses a common ground (negative input of the analog card) and both PLC channels are connected to the same option card, there is cross talk and the values of the two inputs are merged.

Example: if one is inputting 6 mA and the other is inputting 12 mA the two merge and each looks like it is inputting 9 mA.

$$6 + 12 / 2 = 9 \text{ mA}$$

To prevent this cross talk, the PLC must have isolated grounds on the input channels.

LED Status Indicators

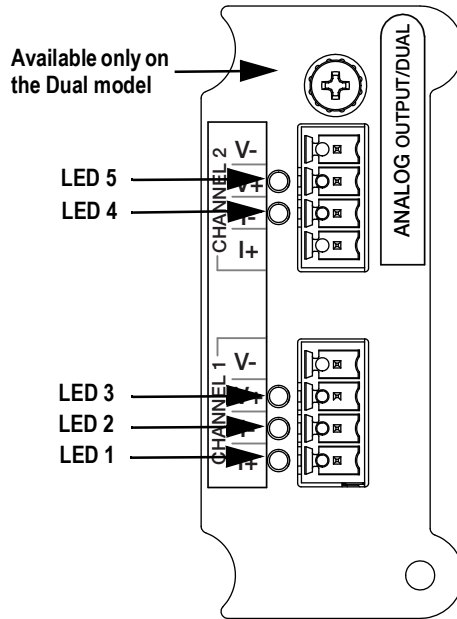

Figure 3. Analog Output Card Faceplate (Dual Analog Output Card)

LED	Status
1	LED Card Status
2	Green – LED Channel 1 is good
3	Red – LED Channel 1 is faulty
4	Green – LED Channel 2 is good
5	Red – LED Channel 2 is faulty

Table 4. LED Status Lights

Specifications

Resolution	16-bit, monotonicity over temperature
Linearity	±0.03% of full scale input
Current Output	0–20 mA or 4–20 mA (20% offset)
Maximum Load Resistance	840 W (840 Ω)
Power Consumption	3.9 W (maximum load at 20 mA)
Voltage Output	0–10 VDC
Minimum Load Resistance	1.1 KW (1.1 KΩ)
Power Consumption	3.9 W (maximum load at 10 VDC)
Input Protection	Short circuit protection, 300 W transient voltage suppression Protection for ESD, EFT (electrical fast transients), tertiary lightning, and system-generated transients per IEC 60001-4-2, 60001-4-4, and 60001-4-5; European Standards EN50082 and EN61000-4



© Rice Lake Weighing Systems Specifications subject to change without notice.
Rice Lake Weighing Systems is an ISO 9001 registered company.

230 W. Coleman St. • Rice Lake, WI 54868 • USA
U.S. 800-472-6703 • Canada/Mexico 800-321-6703 • International 715-234-9171 • Europe +31 (0)26 472 1319