

GUARDIAN™ Printer Enclosure Instructions

1. Open GUARDIAN Cover

With a hex wrench, loosen the two lockdown screws holding the cover closed. Release the latch on the front and open the cover.

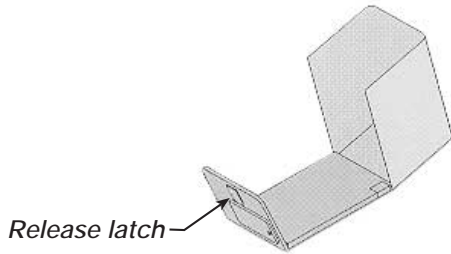

2. Remove Cable Block

Remove the hex head cap screw that holds the cable block. After you have removed the screw, pull the cable block away from the base. This will allow you to run your cables through the enclosure to your printer.

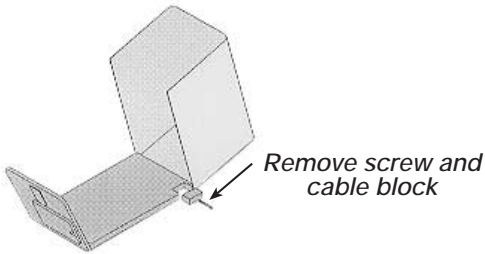

3. Printer Preparation

Before placing the printer in the GUARDIAN enclosure, remove the label access cover from printer.

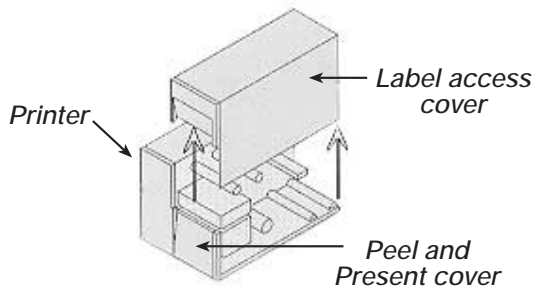

NOTE: I-Class Series Printers; remove additional Peel and Present plastic cover from printer prior to placing the printer into the enclosure.

4. Set the Printer into the Enclosure and Attach Cables and Cable Block

Place the printer onto the base of the enclosure. The printer footpads fit into the recessed holes in the base of the enclosure.

Attach the necessary cables and power cord to the printer. Route the cables and power cord through the cutout where the cable block is installed.

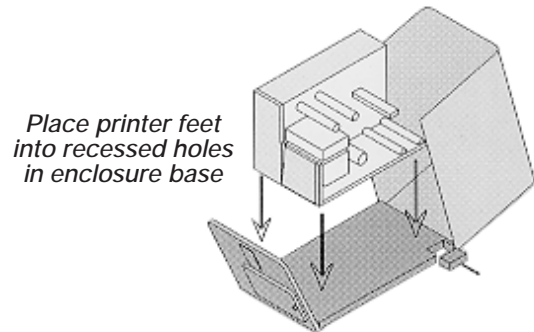

Reinstall the cable entry block. The cables and power cord should be pinched between the gasket of the base and the cable entry block. Insert the hex cap screw through the cable entry block and tighten so that the gasket compresses around the cables.

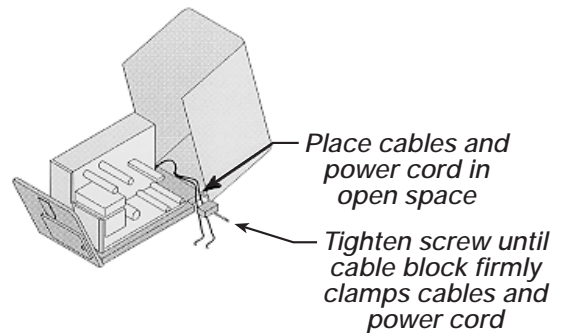

5. Close Cover and Begin Printing

Close and latch the cover. Tighten the lockdown screws. Open the label access door and begin printing labels.