



Picture is a representation of actual product.

Approvals



Order Information

Load Rating	Part #	Est. Weight	Price
10 ft Cable			
10 kg	108685	3 lb	Consult
20 kg	108686	3 lb	Consult
50 kg	108687	3 lb	Consult
100 kg	108688	3 lb	Consult
2.83 ft Cable			
10 kg	107174	3 lb	Consult
20 kg	107175	3 lb	Consult
50 kg	107176	3 lb	Consult
100 kg	107177	3 lb	Consult

Dimensions

Rated Capacity	B	E	F	G	H	I	J
kg/mm							
10 to 100	19.0	25.0	75.0	100.0	17.5	40.0	150.0

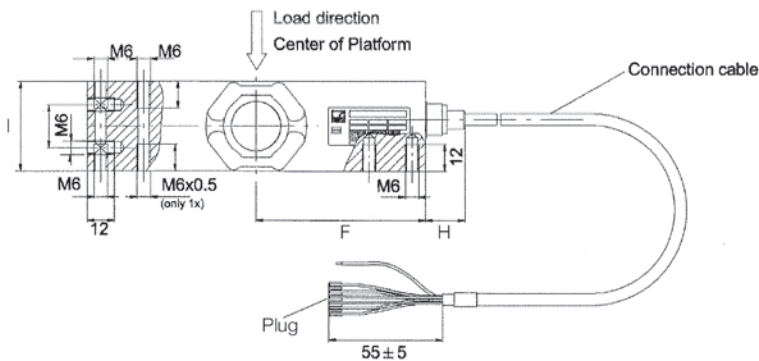

Mounting:
Cylindrical head screw M6-10.9
Tightening torque: 14 N·m

Interchangeable Products

HBK®
PW15AH page 244

Specifications

Full Scale Output:
2.0 mV/V

Output Resistance:
350 (± 10) ohm

Input Resistance:
380 (± 15) ohm

Material/Finish:
Stainless steel

Temperature:
Compensated range
14 °F to 104 °F (-10 °C to 40 °C)
Operating range
0 °F to 150 °F (-18 °C to 65 °C)

Seal Type:
Hermetically sealed, IP69K

Safe Overload:
150% full scale

Rated Excitation:
5 to 10 VDC (15 V maximum)

Combined Error:
0.02% full scale

Insulation Resistance:
1,000 megohm

Cable Length:
10 ft
2.83 ft

Cable Diameter:
0.212 in PVC jacket

Platform Size:
500 × 400 mm

Cable Color Code:
Blue +Excitation
Black -Excitation
White +Signal
Red -Signal
Green +Sense
Grey -Sense

Warranty:
Two-year limited

Approvals:
FM
NTEP 09-015

**RICE LAKE
LOAD CELLS**