

Weigh/Check In Kiosk

Automated Truck Scale System



Shown with PN 176452

Standard Features

Weigh/Check In Kiosk

- 920i® HMI with sun shield
- Four serial ports
- 120 VAC
- Two option slots for 920i option cards
- One-year warranty

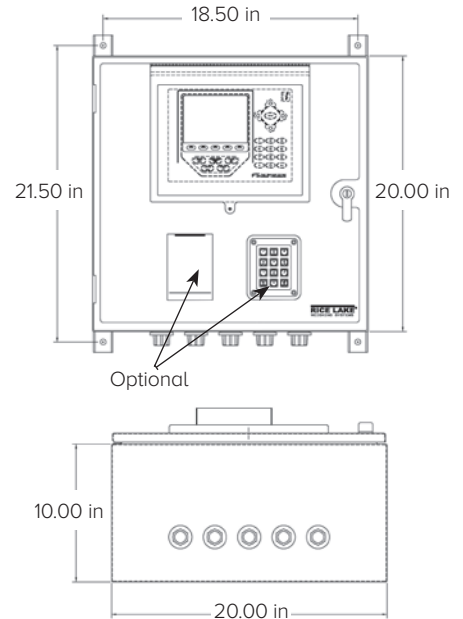

Part Numbers/Price

Part #	Description	Price
153353	Check-in kiosk with 920i HMI, 20 × 20 × 12 in painted mild steel enclosure	Consult

Options/Accessories

Part #	Description	Price
119691	Vandal-proof 12-key keypad	Consult
176452	HID smart card reader	Consult
119692	88 key, panel mount Qwerty style keyboard	Consult
119693	200 watt heater	Consult
119761	Ethernet unmanaged switch, five-port	Consult
119689	Kiosk option, A/D single-channel, includes DIN rail and terminals	Consult
119690	Kiosk option, A/D dual-channel, includes DIN rail and terminals	Consult
119946	Single port Ethernet server	Consult
120040	Dual port Ethernet server	Consult

AUTOMATED TICKETING

Printer Kiosk

Direct Thermal Printer Kiosk



PN 112836

Standard Features

Direct Thermal Printer Kiosk

- Custom America VKP80II receipt printer
- Slide door access to ticket
- 8 in paper roll
- 1 year warranty

Specifications

Line Voltages:

115 or 230 VAC

Frequency:

50/60 Hz

Power Consumption:

0.5 amps (depending on options)

Fusing:

3.15 amps circuit breaker

Humidity:

0 to 95% relative humidity

Printer Communication Ports:

RS-232 or Ethernet

Storage Temperature:

14 °F to 158 °F (-10 °C to 70 °C)

Warranty:

One-year limited

