

# Forklift Questionnaire



Dealer/Company Name \_\_\_\_\_ Contact Person \_\_\_\_\_

## QUESTIONNAIRE

### FORKLIFT SPECIFICATIONS

*If the answer is no, please explain.*

1. Is the lift a typical counterbalance forklift?  Yes  No \_\_\_\_\_
2. Does the forklift have an ITA type carriage? (clip/hook on style forks)  Yes  No \_\_\_\_\_
3. Is the carriage a Class II, 16" profile?  Yes  No \_\_\_\_\_
4. Is the carriage width greater than 36"?  Yes  No \_\_\_\_\_
5. Is the supply power 12 VDC?  Yes  No \_\_\_\_\_
6. Forklift capacity \_\_\_\_\_ 7. Mast Extension \_\_\_\_\_
8. Make \_\_\_\_\_ 9. Model \_\_\_\_\_

### LOAD BACKSTOP

*If the answer to any question below is no, please provide notes under Additional Comments.*

10. Is there a load backstop present?  Yes  No
- If yes, please answer the next questions
- a. Is the backstop bolted to the side of the carriage?  Yes  No
- If yes, please complete Drawing #2
- b. Is the backstop bolted to the front of the carriage?  Yes  No
- If yes, please complete Drawing #3
11. Is this a cable-less application?  Yes  No
- If yes, please complete Drawing #4

### ADDITIONAL COMMENTS

---

---

---

---

### ATTACHMENTS

12. Are attachments present?  Yes  No

If yes, please list attachments below

Description \_\_\_\_\_

Make \_\_\_\_\_

Model \_\_\_\_\_

### LEGAL FOR TRADE

14. Is NTEP required?  Yes  No
15. Is Measurement Canada required?  Yes  No
16. Is the fork length 42" or less?  Yes  No

### INSTRUMENTATION

13. Select preferred instrumentation model  CLS-680  CLS-920i  Virtui3

Drawing #1

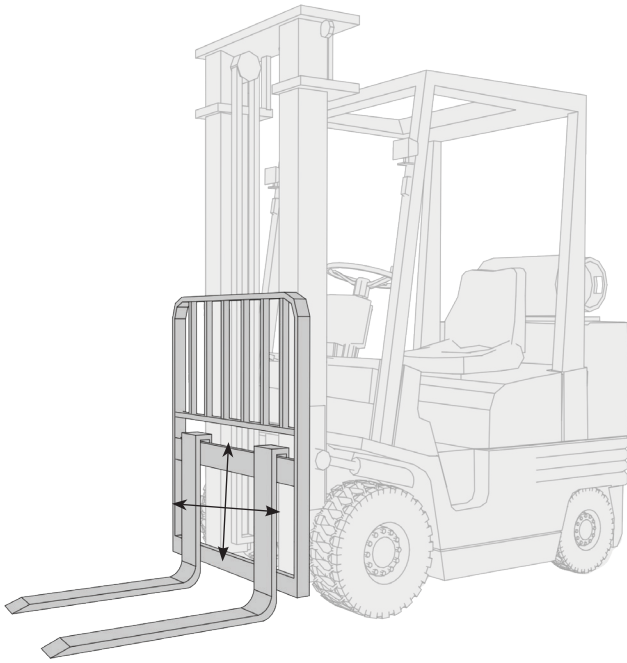

Horizontal Dimension

Vertical Dimension

Drawing #2

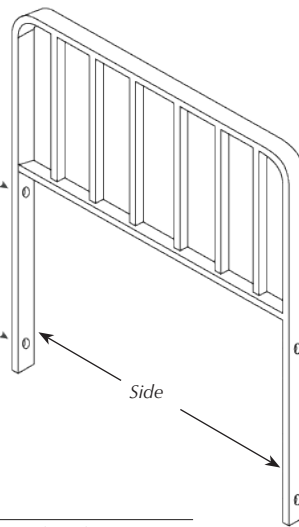

Side

Dimension

Drawing #3

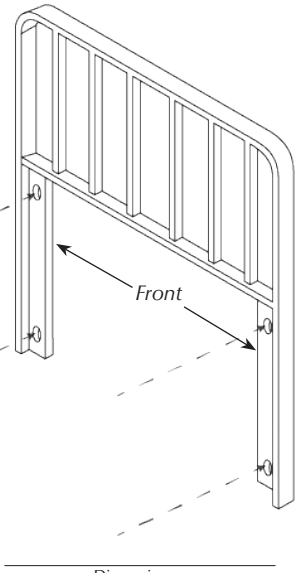

Front

Dimension

Drawing #4

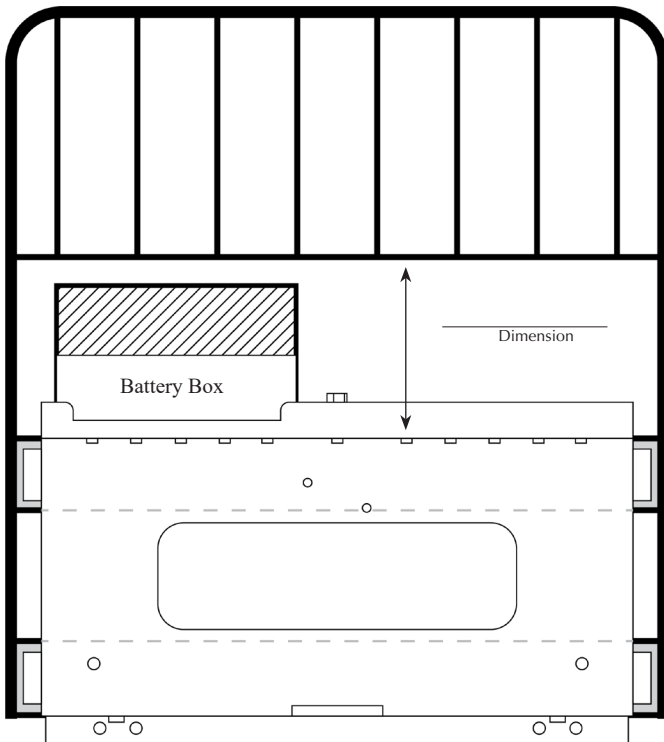

Battery Box

Dimension