

User Manual



GoDEX

ZX1000i+/ZX1000Xi+ Series Thermal Label Printer

User Manual: ZX1000i+/ZX1000Xi+ Series
Version : A.1
Issue Date : 2023/08/31
P/N : 920-018711-00

Contents

1 Thermal Label Printer	5
1.1 Box content	5
1.2 Getting to know your printer	6
2 Printer Setup.....	8
2.1 Loading the label roll	8
2.2 Loading & Removing the ribbon	12
2.3 Connecting the printer to the host computer	14
2.4 Installing printer driver and GoLabel II	15
3 Printer Setting and Control	21
3.1 Operation panel	21
3.2 LCD interface introduction	22
3.3 LCD interface function.....	27
3.4 Label calibration and self test	33
3.5 Error alerts	35
3.6 USB host.....	37
4 NetSetting for Ethernet	39
4.1 Installing the NetSetting software	39
4.2 The interface of NetSetting.....	40
5 Preparation Steps.....	47
5.1 Preparation steps	47
5.2 Installing the cutter	48
6 Maintenance and Adjustment.....	51
6.1 Installing / removing the print head module.....	51
6.2 Adjusting the print line.....	52
6.3 Adjusting ribbon tension.....	53
6.4 Cleaning the thermal print head	54
6.5 Adjusting the balance and print head tension.....	55
6.6 Ribbon shield settings.....	56
6.7 Cutter settings.....	57
6.8 Troubleshooting.....	58
APPENDIX — Product Specifications	59
APPENDIX — Parallel module or Applicator module installation diagram.....	64
APPENDIX — Label Dispenser & Liner Rewind Module Installation	66
APPENDIX — BT & WiFi Module Installation	67
APPENDIX — Wi-Fi setting.....	68
APPENDIX — Wi-Fi Printer Sever Module Installation(Quick Setting).....	74
APPENDIX — Liner Rewind Operation.....	80
APPENDIX — Installation Guide for Perforation Cutter	82
APPENDIX — Installation Guide for Paper Card Cutter.....	85
APPENDIX — High-Speed Cutter (MK147) Installation Guide.....	88

ZX1200i+/ZX1200Xi+ Series FCC COMPLIANCE STATEMENT FOR AMERICAN USERS

Federal Communication Commission Interference Statement

This equipment has been tested and found to comply with the limits for a Class B digital device, pursuant to Part 15 of the FCC Rules. These limits are designed to provide reasonable protection against harmful interference in a residential installation. This equipment generates, uses and can radiate radio frequency energy and, if not installed and used in accordance with the instructions, may cause harmful interference to radio communications. However, there is no guarantee that interference will not occur in a particular installation. If this equipment does cause harmful interference to radio or television reception, which can be determined by turning the equipment off and on, the user is encouraged to try to correct the interference by one of the following measures:

- Reorient or relocate the receiving antenna.
- Increase the separation between the equipment and receiver.
- Connect the equipment into an outlet on a circuit different from that to which the receiver is connected.
- Consult the dealer or an experienced radio/TV technician for help.

This device complies with Part 15 of the FCC Rules. Operation is subject to the following two conditions:

(1) This device may not cause harmful interference, and (2) this device must accept any interference received, including interference that may cause undesired operation.

FCC Caution: Any changes or modifications not expressly approved by the party responsible for compliance could void the user's authority to operate this equipment.

TO WHICH THIS DECLARATION RELATES IS IN CONFORMITY WITH THE FOLLOWING STANDARDS

EN IEC62368-1:2018

EN 55032:2015/A11:2020 Class B EN IEC 61000-3-2:2019

EN 61000-3-3:2013+A1:2019

EN 55035:2017/A11:2020

IEC 61000-4-3 Edition 3.2 2010-04, IEC 61000-4-4 Edition 3.0 2012-04,

IEC 61000-4-5 Edition 3.1 2017-08, IEC 61000-4-6 Edition 4.0 2013-10,

IEC 61000-4-8 Edition 2.0 2009-09, IEC 61000-4-11 Edition 2.1 2017-05

AS/NZS CISPR 32:2015 Class B

CISPR PUB. 22,FCC Part 15 Subpart B

SAFETY INSTRUCTIONS

Please read the following instructions carefully.

1. Keep the equipment away from humidity.
2. Before you connect the equipment to the power outlet, please check the voltage of the power source.
3. Make sure the printer is off before plugging the power connector into the power jack.
4. It is recommended that you connect the printer to a surge protector to prevent possible transient overvoltage damage.
5. Be careful not to get liquid on the equipment to avoid electrical shock.
6. For safety and warranty reasons, ONLY qualified service personnel should open the equipment.
7. Do not repair or adjust energized equipment under any circumstances.

* The cutter is an optional accessory. If the cutter is installed, it is not suitable for children to approach.

Caution

- * Danger of explosion if battery is incorrectly replaced. Replace only with the equivalent type recommended by the manufacturer.
- ** Dispose of used batteries according to the manufacturer's instructions.
- *** Only use with designated power supply adapter model.
- **** Changes or modifications not expressly approved by the party responsible for compliance could void the user's authority to operate the equipment.

Specifications are subject to change without notice.

1 Thermal Label Printer

1.1 Box content

Please check that all of the following items are included with your printer.

(Package content and Logo style may vary per region.)

- Barcode Printer

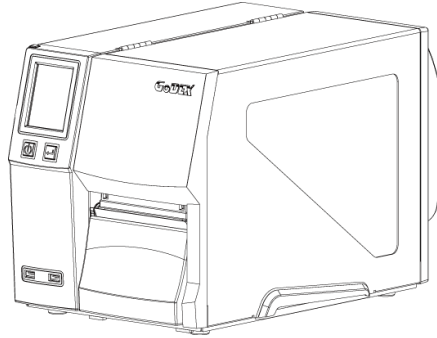

- Label Stock

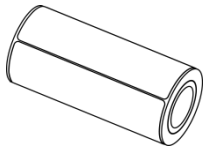

- USB Cable

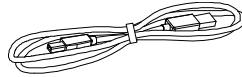

- Quick Guide



- Ribbon

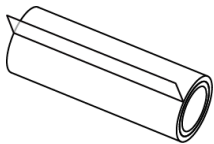

- Power Cord

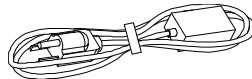

1.2 Getting to know your printer

Device Overview

•Front View

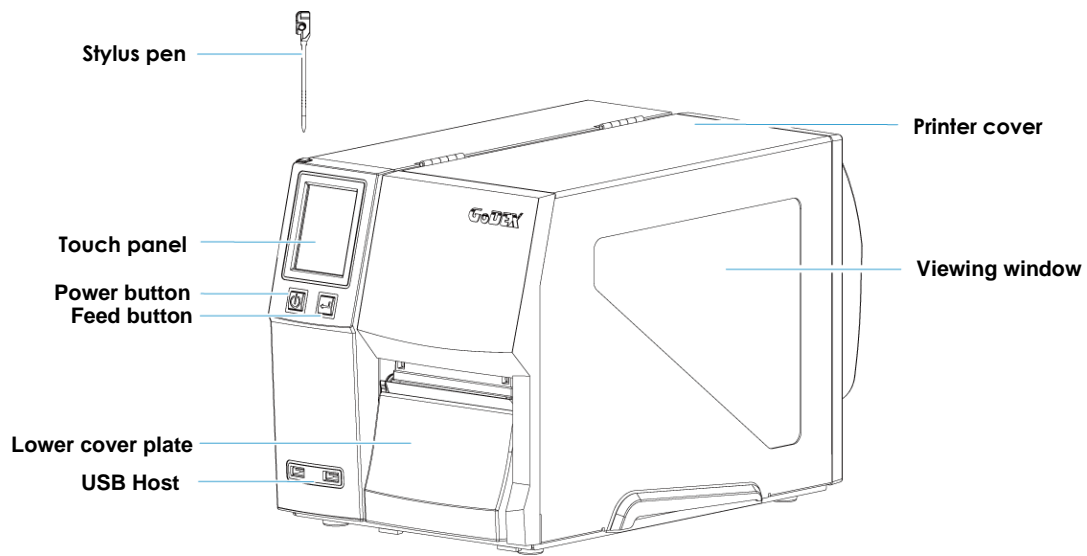

•Rear View

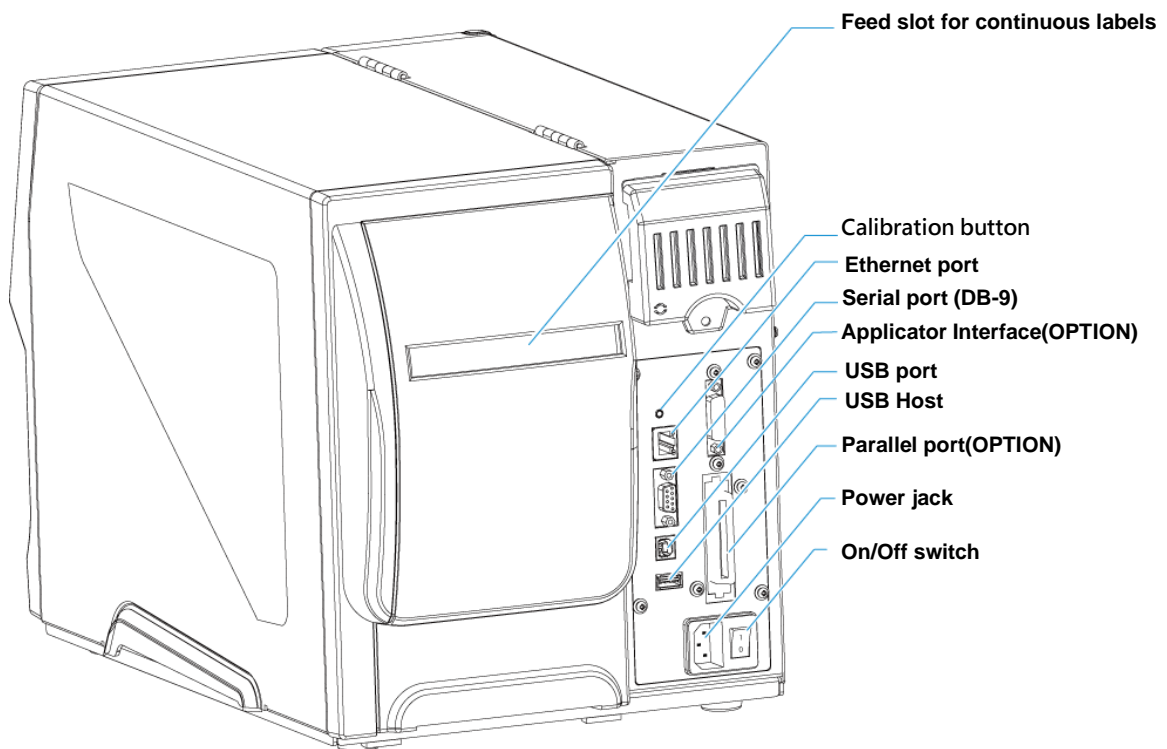

•The Internal View of Printer

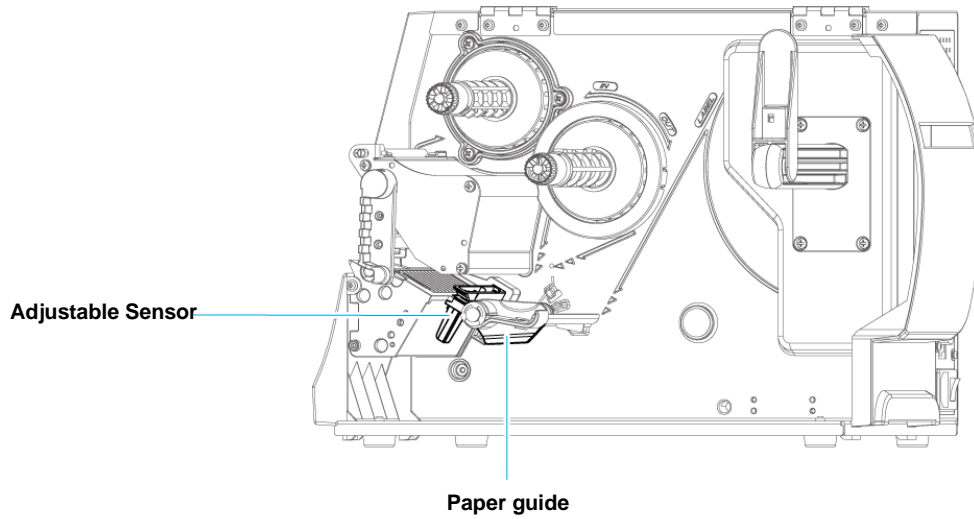
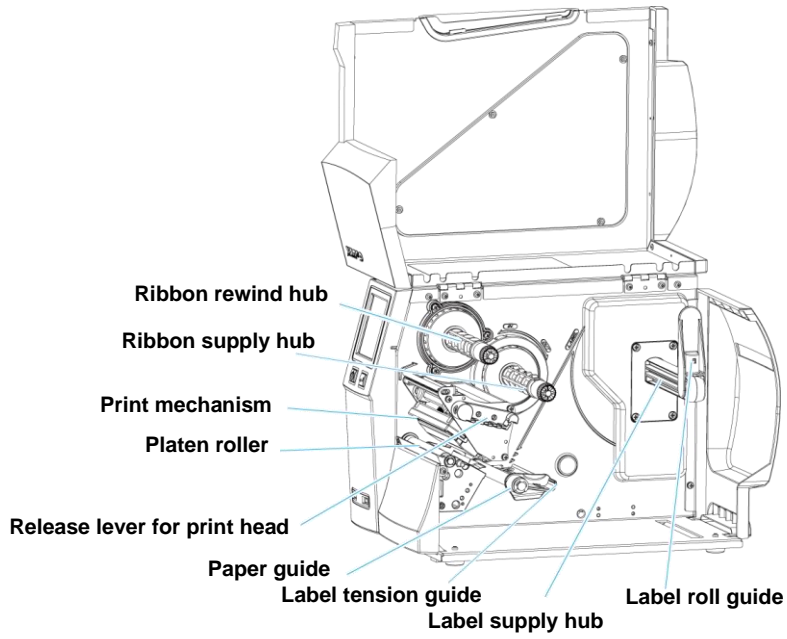

2 Printer Setup

2.1 Loading the label roll

This printer supports the following printing methods:

Thermal transfer printing (TTP) : Requires a ribbon for transferring a printed image to a medium.

Direct thermal printing (DTP) : Does not require a ribbon, only thermal paper.

Please check which printing method you are using and alter the settings accordingly in the printer driver, printer menu, and/or software.

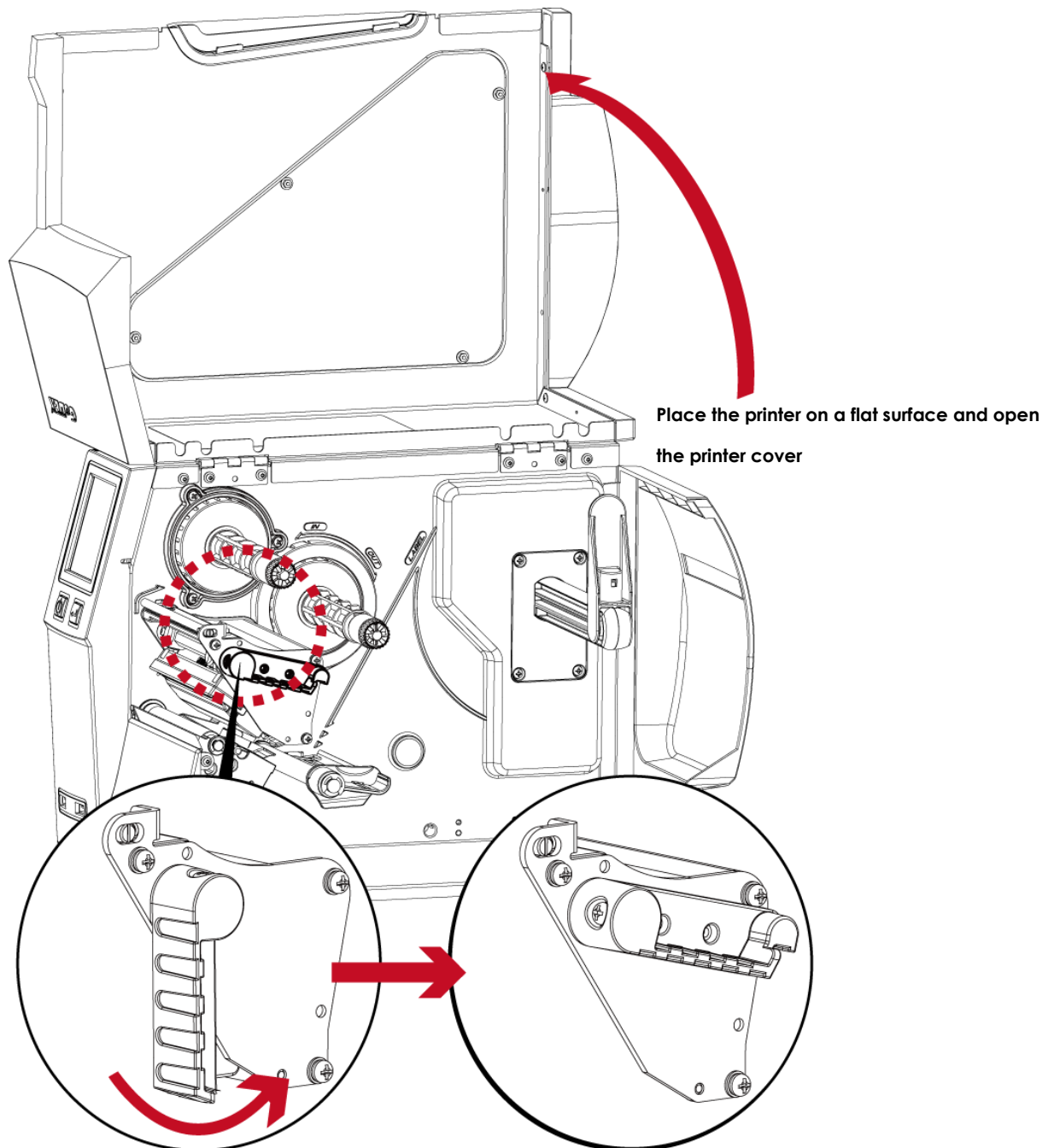

Place the printer on a flat surface and open the printer cover

Turn it anticlockwise to a top right position as shown in the illustration

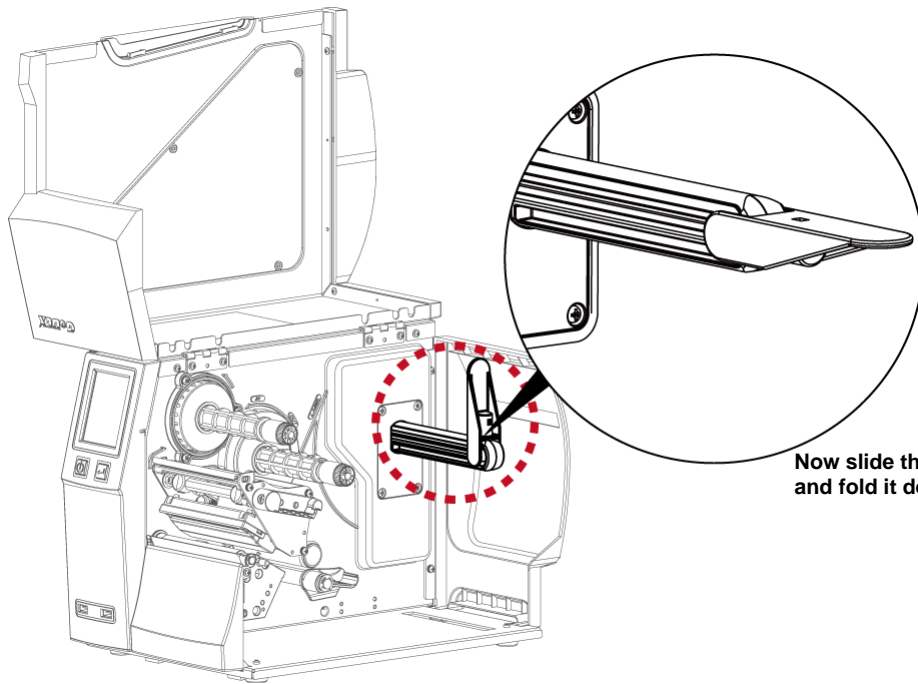

Now slide the label roll guide forward and fold it down

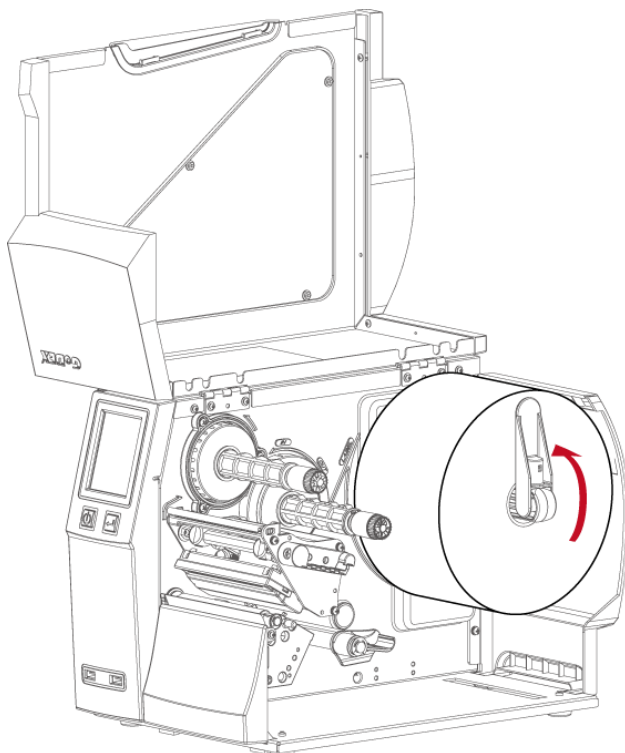

Place the label roll on the label supply hub, pushing it right up to the printer housing. (Do not apply too much pressure to avoid damaging the label stock.)

Note

* When moving the label roll guide, hold it only by the end that is attached to the bracket, not by its top.

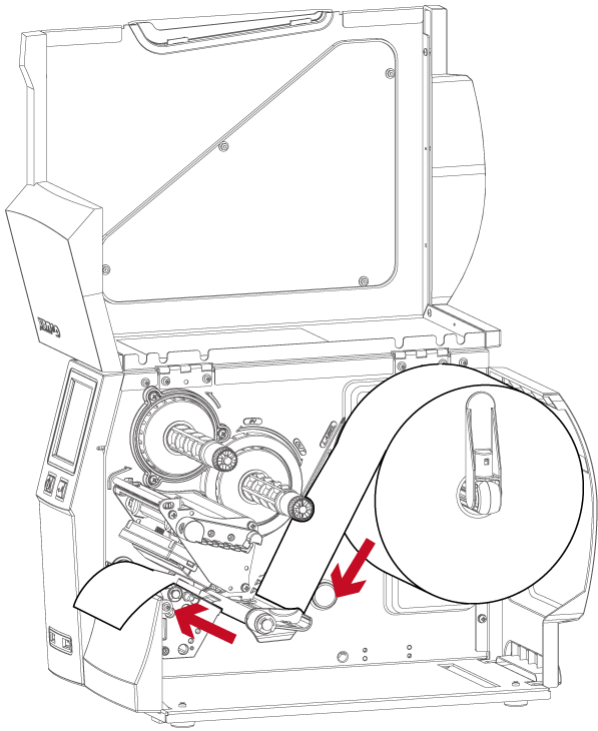

Load the label roll into the printer as shown in the illustration. Pass it through the printer as indicated by the red arrows.

Pass the label stock through the Adjustable Sensor and up to the tear-off plate.

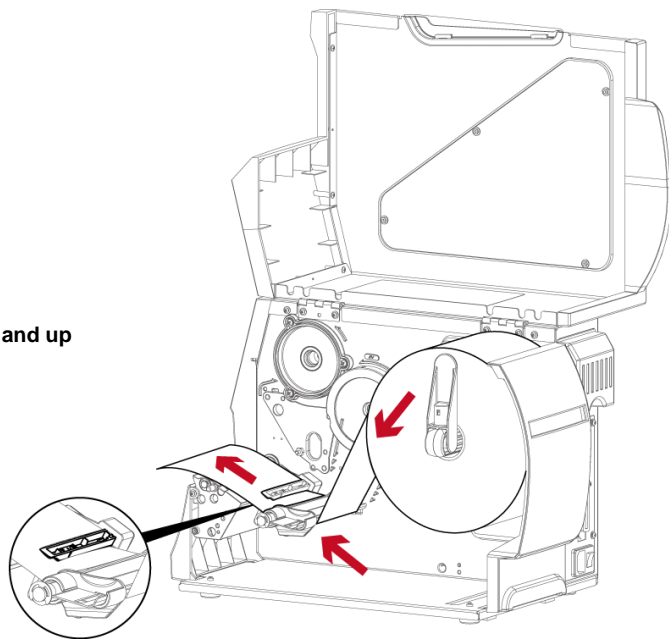

Note

* Remember to set the movable sensor to gap, black mark, or tag hole by changing the position of the sensor with the adjustment wheel.

2. Return the print head release lever to its original position.

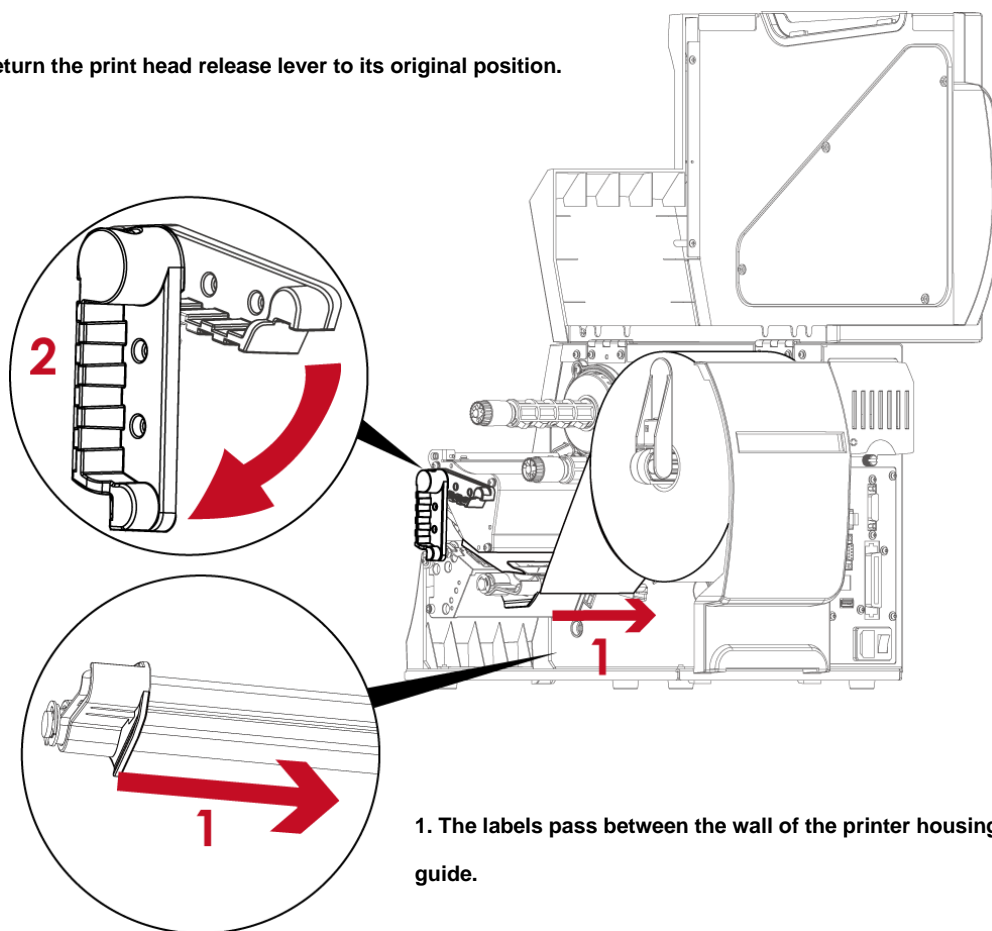

1. The labels pass between the wall of the printer housing and the adjustable paper guide.

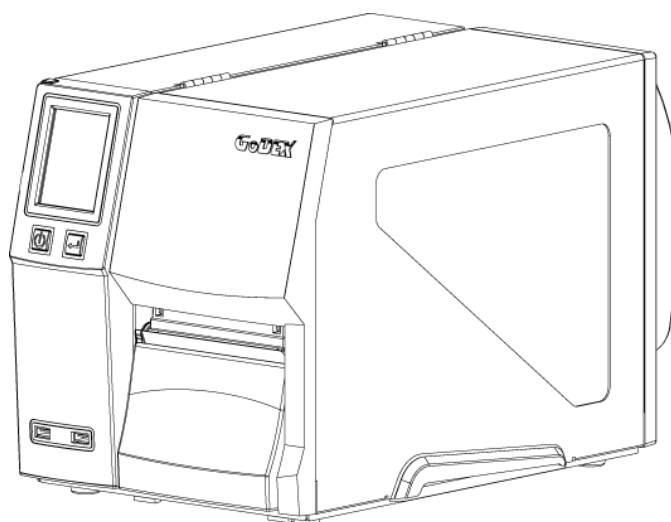

Then close the printer cover.

2.2 Loading & Removing the ribbon

Loading Ribbon

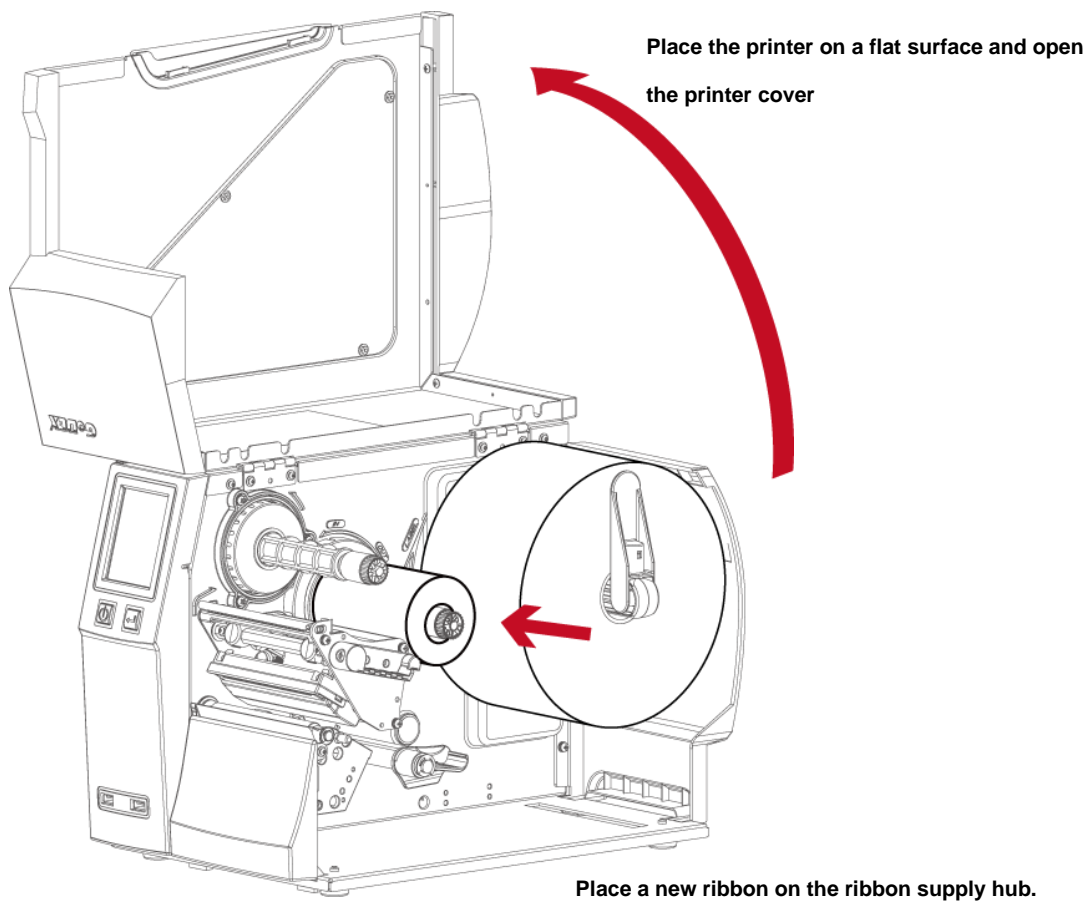

The two illustrations as below show you how to install the ribbon depending on the ribbon type (ink side in or out).

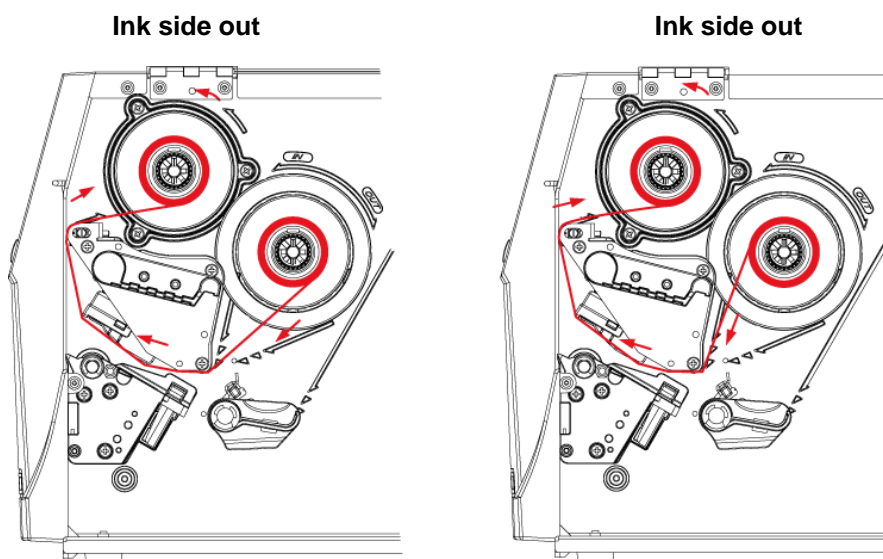

Pass the ribbon under the print head and back up on the other side.
Attach it to the empty ribbon core.

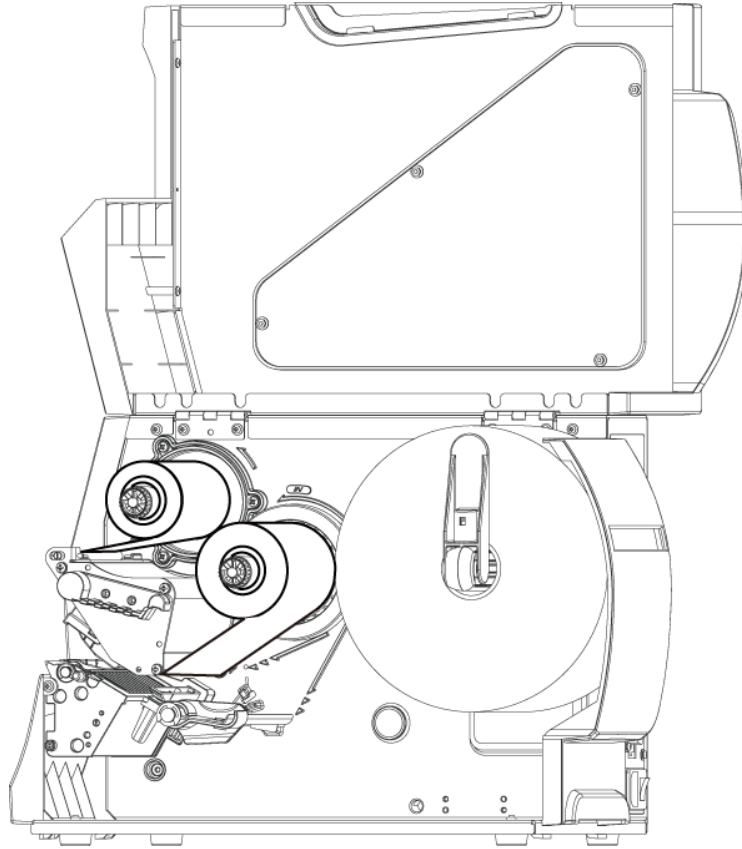

Note

* Do not pass the ribbon under the sensor.

2.3 Connecting the printer to the host computer

1. Please make sure that the printer is switched off.
2. Connect the power cord to the AC adapter and connect the adapter to the printer.
3. Connect the USB cable to the printer and host computer.
4. Switch on the printer. The operator panel should now light up.

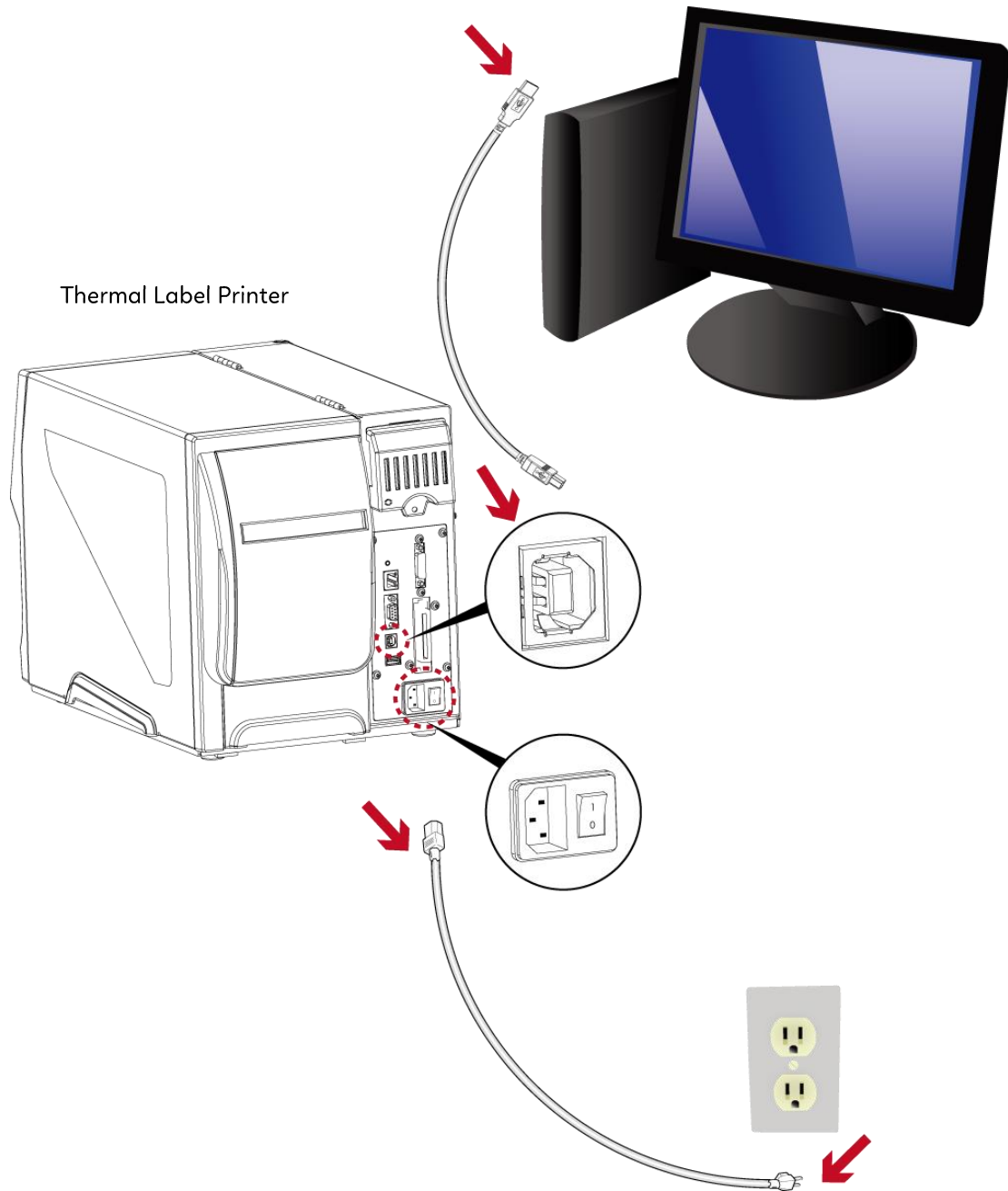

2.4 Installing printer driver and GoLabel II

Relevant documents and software can be found and download on GoDEX official website.

Driver

Step1. Click the compressed driver file in the folder.

Select "I accept the terms in the license agreement." and click "Next".

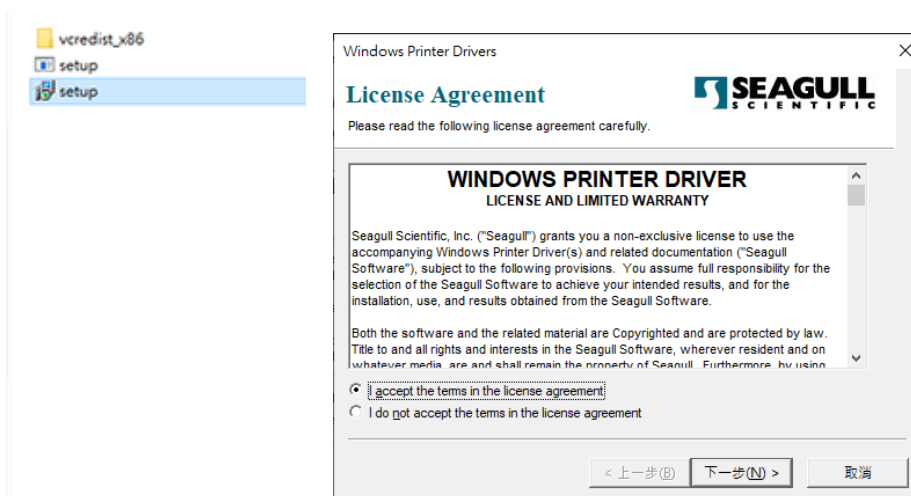

Step2. Select the path to unzip and click "Next"

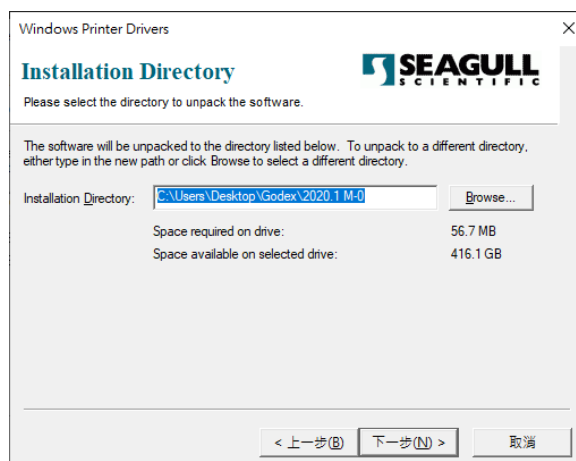

Step3. Click "Finish" and open the Driver Wizard

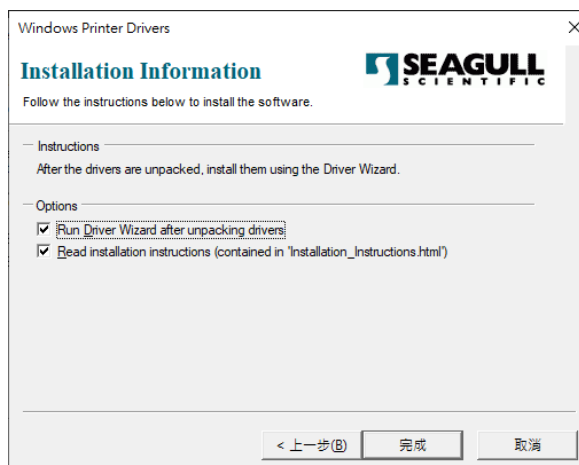

Step4. The driver installation wizard will automatically detect the model, please click "Next" to start the installation.

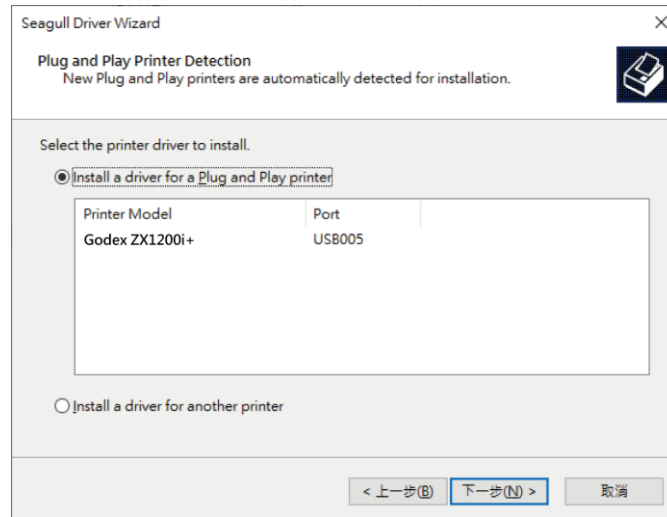

Step5. After entering the printer name, click "Next"

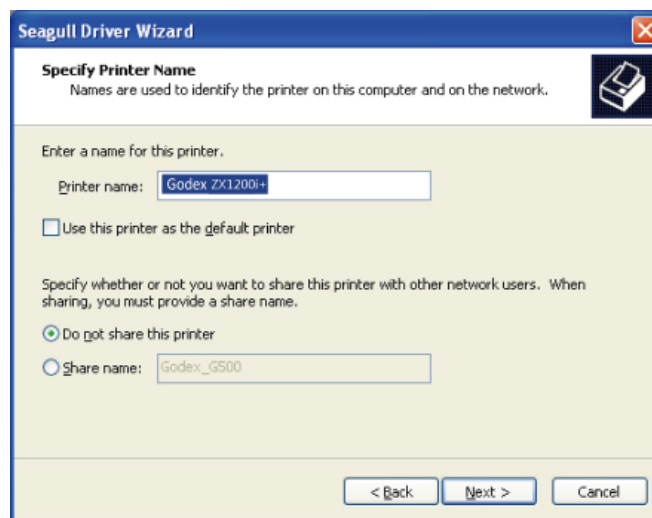

Step6. After confirming the settings, click "Finish" to install.



Step 7. Once the driver installation is complete, the new printer should appear in the "Printers and Faxes" folder.

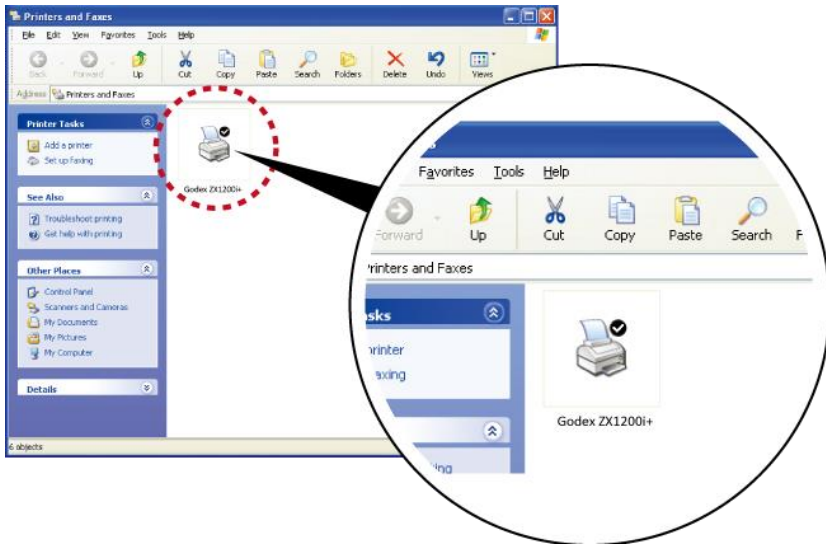

Installing GoLabel II

Step1. Click the installer in the folder to install.

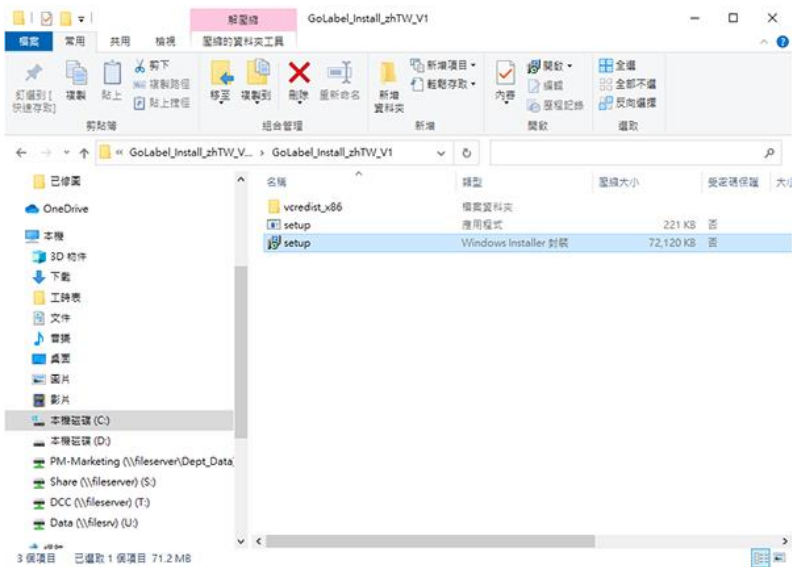

Step2. After entering the installation screen, click "Next".



Step3. After selecting the folder to install, click “Next”

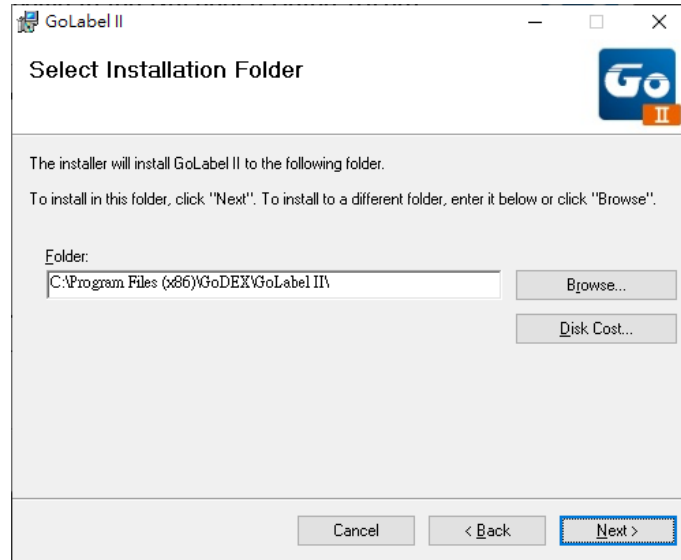

Step4. Click Next to start the installation.

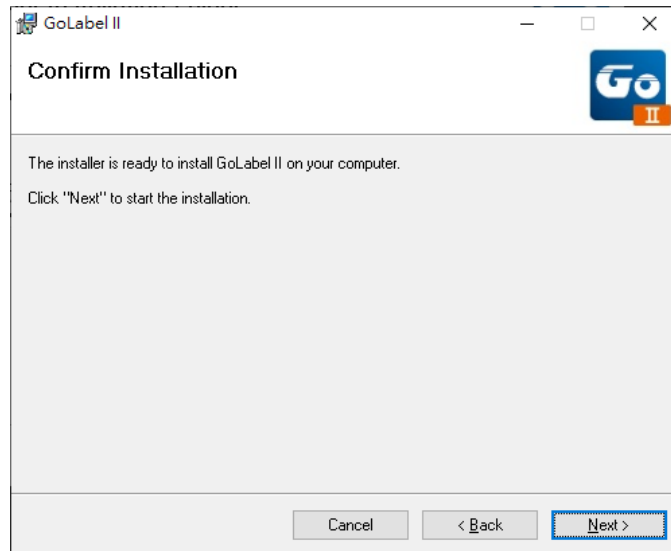

Step5. Finish installation

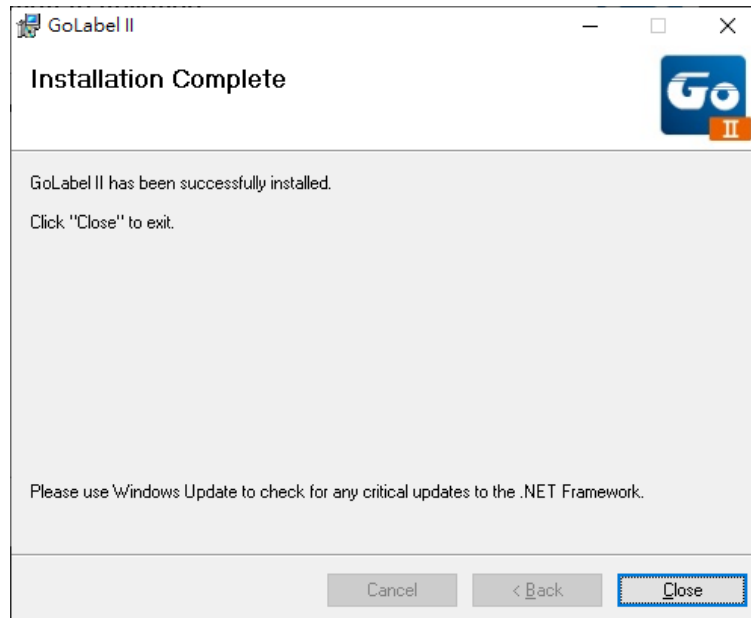

3 Printer Setting and Control

3.1 Operation panel

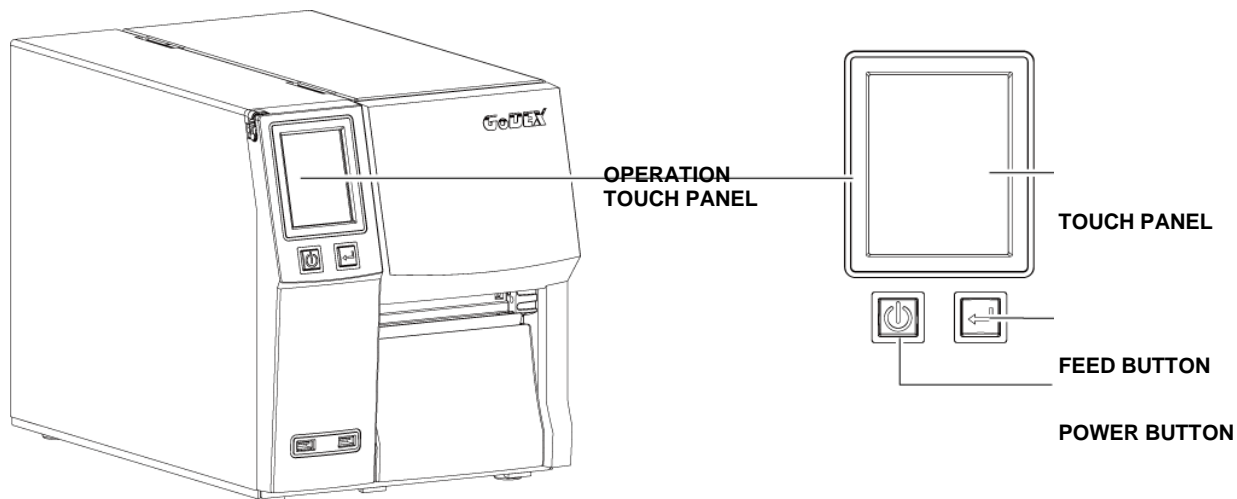

POWER Button

Press the POWER button to turn on the printer, and the START UP SCREEN appears. The printer is on “ready to print” status, the LCD screen should display the message “READY” on the screen.

When printer is turned on, hold and press down the POWER button for 3 second will turn the printer off.

FEED Button

Turn on the printer and press the FEED button.

When you press the FEED button, the printer will advance media until the FEED button is released.

If you are using continuous labels, pressing the FEED button will advance a length of media until the button is released.

If you are using media with gaps, pressing the FEED button once will advance only one label.

If the label does not stop at the correct position, you need to run the auto-detection function for your media, please see Section 3.4 Label Calibration and Self-Test.

PAUSE PRINTING_FEED Button

Pressing the FEED button while the printer is in standby mode will set the printer to pause mode. In this mode, the printer can receive commands, but it will only process them when it is reset to standby mode. Pressing the FEED button again will reset the printer to standby mode.

Pressing the FEED button during printing will interrupt printing. When the FEED button is pressed again, the printer resumes printing. Example: While a 10-label print job is running, you press the FEED button to pause the printer.

Two of the labels have been printed. To resume printing and print the remaining eight labels, you will need to press the FEED button again.

CANCEL PRINTING_FEED Button

Press and hold the FEED button for 3 seconds during printing cancels a print job. The current print job is cancelled.

Example: While a 10-label print job is running, you press the FEED button. Two of the labels have been printed.

The print job is cancelled and the remaining eight labels will not be printed.

3.2 LCD interface introduction

Getting Started

Press the POWER button to turn on the printer, and the START UP SCREEN appears.



If the printer is on "ready to print" status, the LCD screen should display the message "Ready" on the screen.

Use touch gestures to get around the Home screen and other screen for setting.

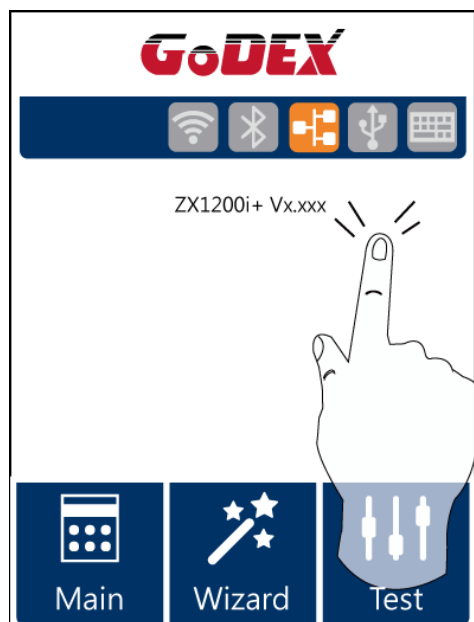

Tap the screen with your finger or the stylus pen when you want to select on screen items such as settings icons.

On the Ready Page, three function mode for setting. You can make various setting functions in FUNCTIONAL MODE.

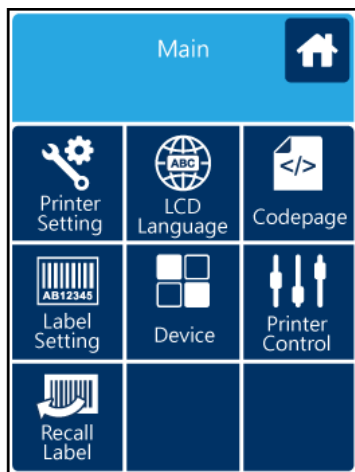

Tap "Main" --

Screen could show more detail of "Main"

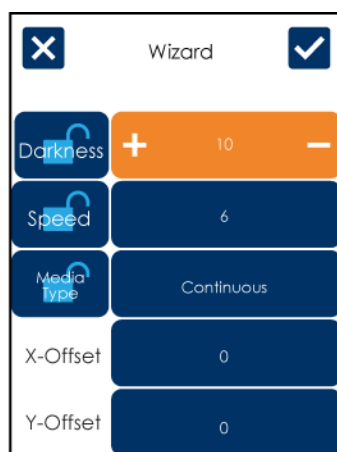
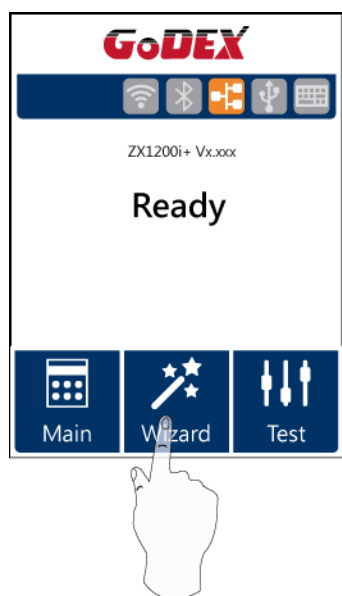

Tap "Wizard" --

Set up printer of "Darkness" "Speed" ...

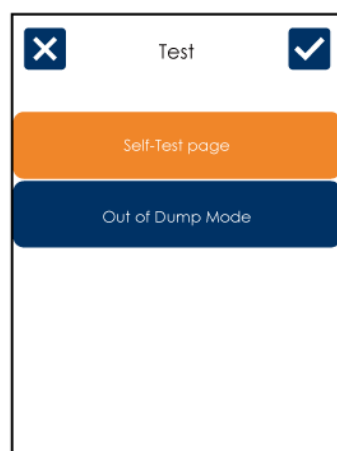

Tap "Test" --

self-Test page and Out of Dump Mode for setting.

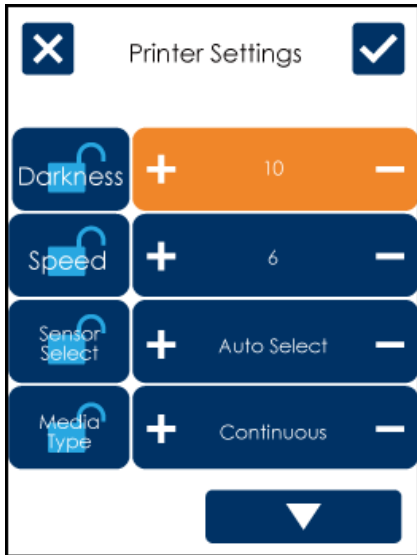

finish setting tap  back to main page

if do not save, tap  system would not save any changes.

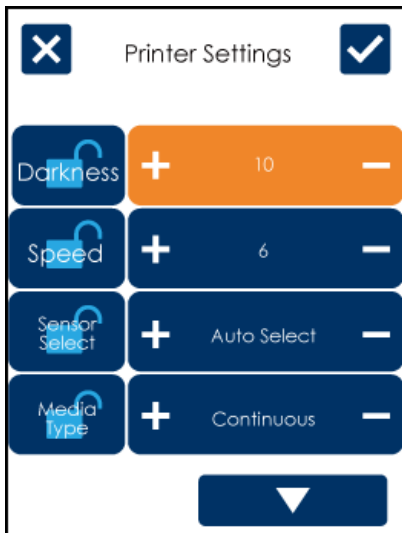
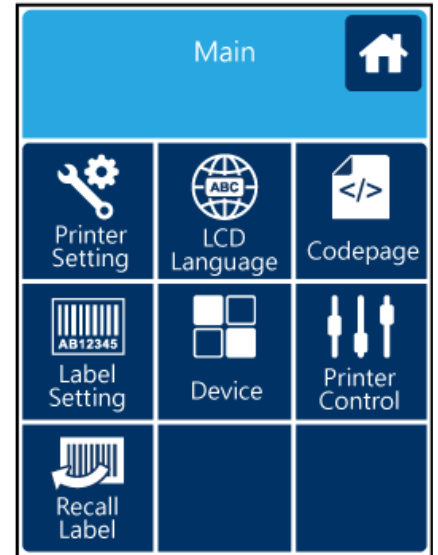

UNLOCK



LOCK

If printer functions locked, printer can not receive any commands from GoLabel or any devices.

Keyboard Mode

When plug-in an USB keyboard to the printer, LCD touch panel will display “Enter Standalone”, press the “Y” key on keyboard to entering to the dialog for “Keyboard Mode” operation.

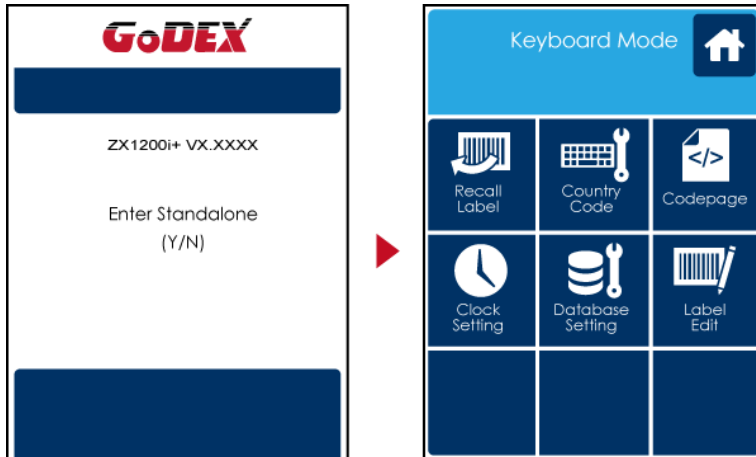

Preview Label function

User can choose any labels which have done in the printer and preview it. (See Instructions)

From the Home screen, tap  to Main Page.

From the Main Page tap Recall Label to Recall Label Page.

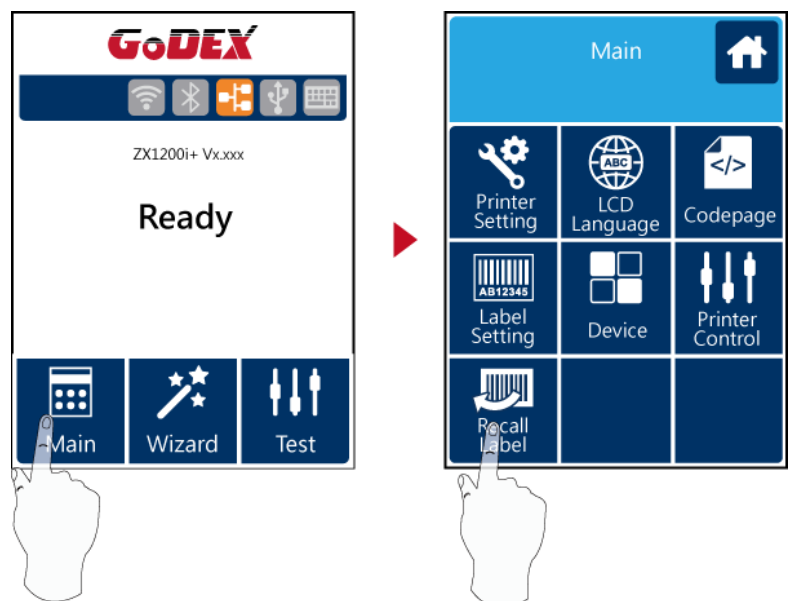

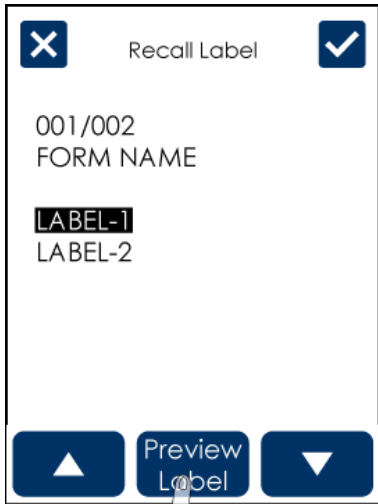

From the Recall Label page, the touch panel shown on all labels. The Data processing time will be extended as long as the labels increase.

Tap  to choose labels.

Tap  to choose labels.

Tap  Label can see printing label

Keeping tap  to next page

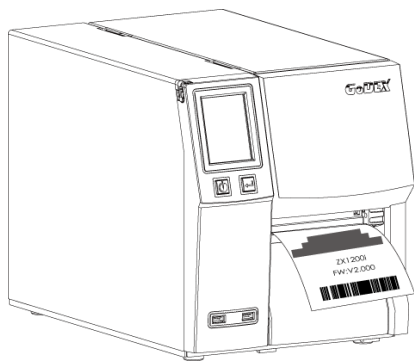
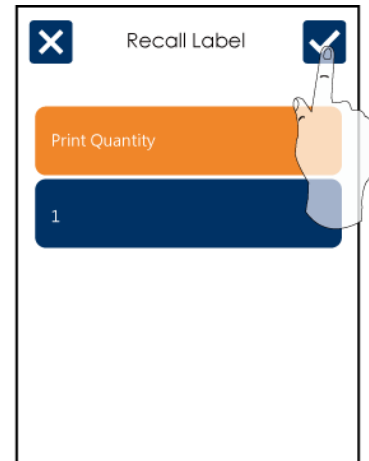
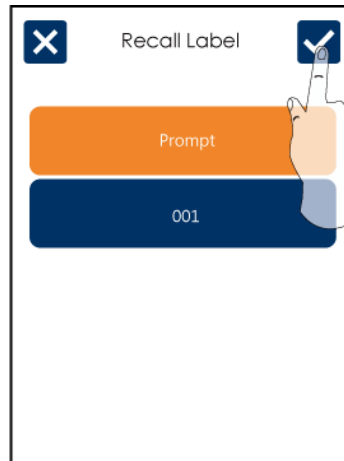

Print out selected label.

Note

* Using recall label function send commands, printer display must be back to Ready Page.



3.3 LCD interface function

Main Page

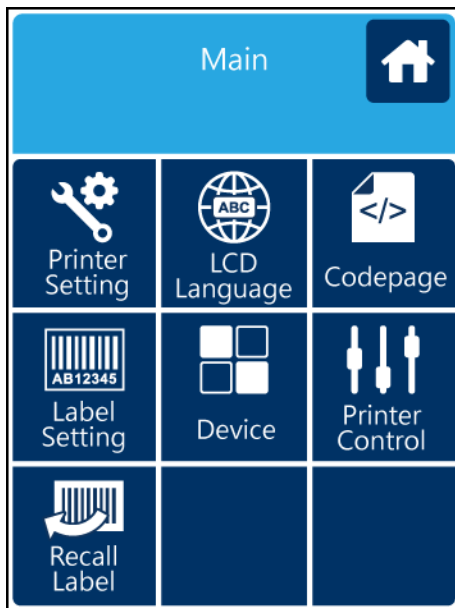

Setting items for printer, ex. Printing speed, darkness. Also includes a Printing Wizard for your ease of printing.



More than 10 languages for printer setting



It consists of a table of values that describes the character set for a particular language



Setting items for printing label, ex. Rotation, Printing position offset.



Option modules and connection port settings.



Self-Diagnose functions for printer, ex. TPH testing, self-test page printing.



Recall Label

Device Page



Setting off or on for buzzer



Setting items for options, ex. Cutter, Label Dispenser, Applicator



Setting Programing Language. Auto/EZPL/GEPL/GZPL/GDPL



Setting items for Serial Port, ex. Baud Rate, Parity, Data Bits, Stop Bits.



Setting items for LAN, ex. Port NO., DHCP, Dynamic IP, Default Gateway, Subnet Mask.



Setting items for LCD, ex. Brightness, Contrast, Power Saving, Password



Setting items for Clock, ex. Year, Month, Day, Hour, Minute

Setting Items in Setting Mode



Printer Setting

Darkness	0-19
Speed	2-5
Sensor Select	Media Detection
	Auto Select
	See-Through
	Reflective
	Label with Gaps
Media Type	Label with Marks
	Continuous
Printing Mode	Direct Thermal
	Thermat Transfer
Tear-off Position	0-40
Top of Form	Apply
	Cancel



LCD Language

English
Deutsch
繁體中文
簡體中文
Français
Español
日本語
Italiano
Русский
Türkçe



Codepage

850
852
437
860
863
865
857
861
862
855
866
737
851
869
Win 1252
Win 1250
Win 1251
Win 1253



		Win 1254
		Win 1255
		Win 1257
Label Setting		Rotation
		X-offset
		Y-offset
		Start Offset
	Buzzer	OFF
	ON	
Optional Setting		None
		Cutter
		Label Dispenser
		Applicator
Programing Language	Auto/EZPL/GEPL/GZPL/GDPL	
Serial Port Setting	Baud Rate	4800 bps
		9600 bps
		19200 bps
		38400 bps
		57600 bps
		115200 bps
	Parity	Non
		Odd
		Even
Data bits	7 bits	
	8 bits	
Stop bits	1 bits	
	2 bits	
LAN Setting	DHCP	On
	IP Address	192.168.102.076
	Subnet Mask	255.255.255.0
	Gatway	192.168.0.254
LCD Setting	Brightness	5
	Contrast	5
	Power Saving	15
	Password	OFF
Clock Setting	Year	
	Month	
	day	
	Hour	
	Minute	
Printer Control	Test	
	Sample Pattern	

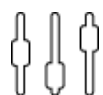

Select Memory

Clear Memory

Calibration

Reset to Default



Recall Label

Status of LCD Interface

When printer is on standby status (ready to print), the LCD interface will display “Ready” on screen.

You can only print when you see the “Ready” status.





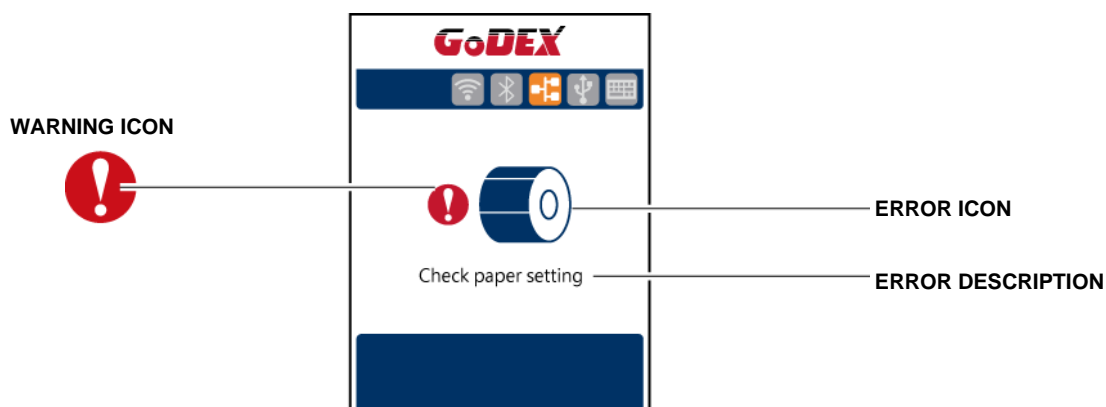

If there is any printers error, the LCD screen will display the error screen to show the type of error.

You can fix the error according the notice.



Icon Definition

	To upper level	Appears on the NAVIGATION ICON of Setting Pages. It guides you back to upper level by touching display upper right icon.
	To main page	Appears on the NAVIGATION ICON of Setting Value Pages. It guides you back to main page by touching display upper left icon.
	Lock	On Setting Value pages, touch display icons to lock the value for preventing unexpected change.
	Unlock	Touch display icons again to unlock the value.

3.4 Label calibration and self test

Label Calibration

The printer can automatically detect and store label height.

That means the host computer does not need to transmit the label height to the printer.

Self Test

Self-test function lets you check whether the printer is functioning normally.

Here is how you run the label size calibration and self test.

1. Check that the label stock is loaded correctly.
2. Turn off the printer.
3. Turn the printer on again, keeping the FEED button pressed. When the LED starts to flash red, release the FEED button.

The printer will now measure the label stock and store the label height.

4. Once the printer has successfully measured the label stock, it will print a self-test label.

The contents of a self-test printout are listed below.



Model & Version	ZX1200i+: XX.XXX
USB ID setting	USB S/N:12345678
Serial port setting	Serial port:96,N,8,1
MAC address of Ethernet port	MAC Addr:xx-xx-xx-xx-xx-xx
IP protocol setting	DHCP Enable
IP address of Ethernet port	IP xxx.xxx.xxx.xxx
Gateway setting	Gateway xxx.xxx.xxx.xxx
Netmask setting	Sub-Mask xxx.xxx.xxx.xxx
	#####
Number of DRAM installed	1 DRAM installed
Image buffer size	Image buffer size:1500 KB
Number of forms	0000 FORM(S) IN MEMORY
Number of graphics	0000 GRAPHIC(S) IN MEMORY
Number of fonts	000 FONT(S) IN MEMORY
Number of Asian fonts	000 ASIAN FONT(S) IN MEMORY
Number of Databases	000 DATABASE(S) IN MEMORY
Number of Scalable fonts	000 TTF(S) IN MEMORY
Free memory size	4073 KB FREE MEMORY
Speed, Density, Ref. Point, Print direction	^S4 ^H8 ^R000 ~R200
Label width, Form length, Stop position	^W102 ^Q100,3 ^E18
Cutter, Label Dispenser, Mode	Option:^D0 ^O0 ^AD
Sensor Setting	Reflective AD:1.96 2.84 2.49[0.88_23]
Code Page	Code Page:850

Label Calibration Button

A hardware button to make a Label Calibration while printer encountering “Media Error” during the cases when first-time printer start up or change label or ribbon to another type, such as change using gap label to continuous or black mark labels.

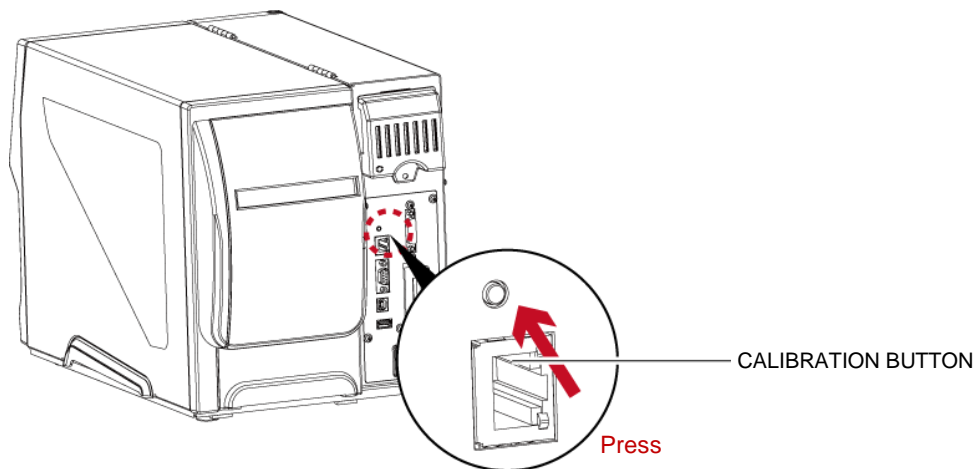

Press C-button for 2 seconds, it will make an auto-sensing to calibrate the label and ribbon's parameters.

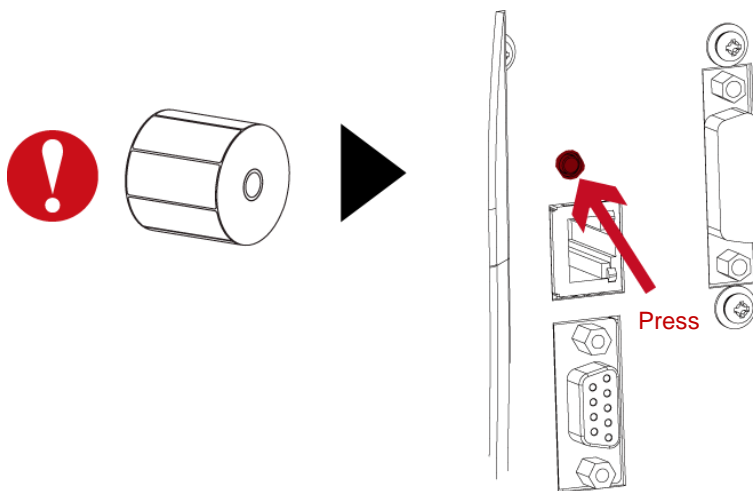

Note



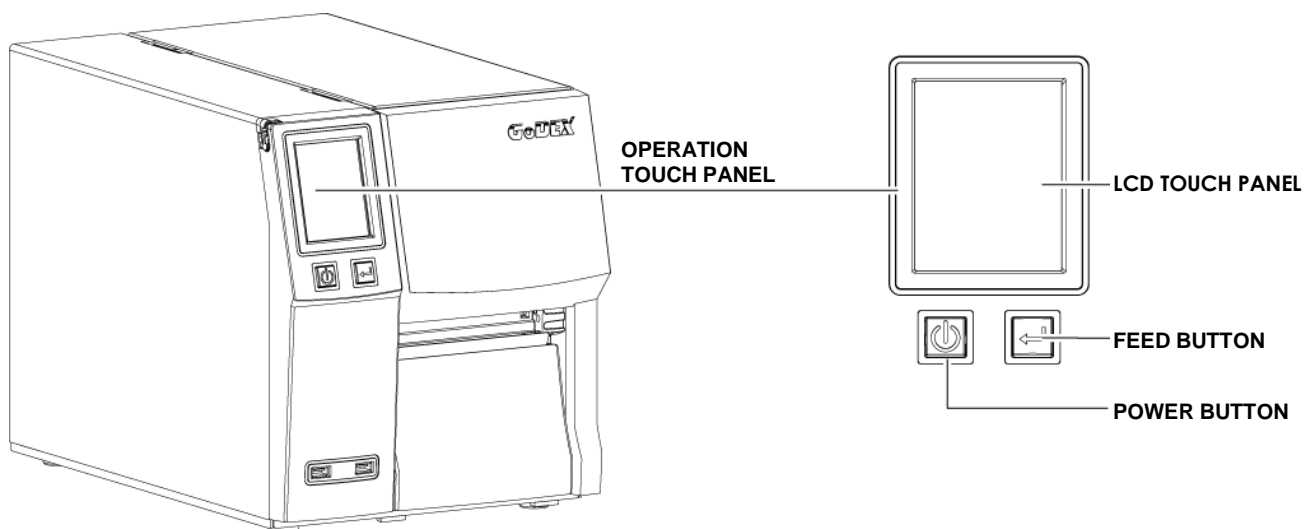

- * Press C-button is equivalent to the auto-sensing command “~S,SENSOR” that will cancel on-printing-job and make the Label Calibration immediately.

3.5 Error alerts

In the event of a problem that prevents normal functioning of the printer, you will see an error message on LCD screen and hear some beep signals. Please refer to below table for the error alerts.



Operation Panel Status	Type	Beeps	Description	Solution
 TPH OPEN TPH opened	Print Head Error	2 x 4 beeps	The printing mechanism is not correctly closed.	Open the print mechanism and close it again.
 TPH overheat	Print Head Error	None	High temperature at the print head.	Once the print head has cooled down, the printer switches to standby mode.
 Check ribbon	Media Error	2 x 3 beeps	No ribbon is installed and the printer displays an error.	Make sure that the printer is set to direct thermal printing mode.
			The ribbon is finished or the label supply hub is not moving.	Replace the ribbon roll.
	Media Error	2 x 2 beeps	No paper is detected.	Make sure that the label sensor is positioned correctly. If the sensor still does not detect the paper,

				run the autodetection function again.
			Paper is finished.	Replace the label roll.
			Printer feed problem.	Possible reasons: the print medium has become trapped around the rubber roll; the sensor cannot detect a gap or black mark between the labels; there is no paper. Please reset the sensor
  	File Error	2 x 2 beeps	The memory is full. The printer prints the message "File System full".	Delete unnecessary data or install additional memory.
			Unable to find file. The printer prints the message "File Name not found"	Use the "~X4" command to print all files. Then check whether the files exist and whether the names are correct.
			A file of the same name already exists. The printer prints the message "Duplicate Name".	Change the name of the file and try storing it again.

3.6 USB host

Definition : USB Host port supports either device : USB memory stick, keyboard or scanner.

Purpose

- USB memory stick : It extends the user memory space up to 32GB for Graphic, Font, Label Format, DBF and Command files downloading. The printer's Firmware also can be updating if copy new version of Firmware into USB memory stick.
- Connecting an USB keyboard to printer for "Keyboard Mode" mode operation.
- Plug-in an USB scanner to operate the printer in "Keyboard Mode".

Usage of Extended Memory

- USB memory stick : It supports hot-plugging function; printer will create a Folder "\LABELDIR" and switch "User Flash" to "Extended Memory" automatically while user plugs an USB memory stick into a GoDEX printer.
- Connect the USB Stick plugged -in printer to PC via USB Device or Ethernet port and run "GoLabel" software to download Graphic, Font, Label Format, DBF and Command files to the printer.
- Detail download procedures, please refer to "GoLabel On-line Help".

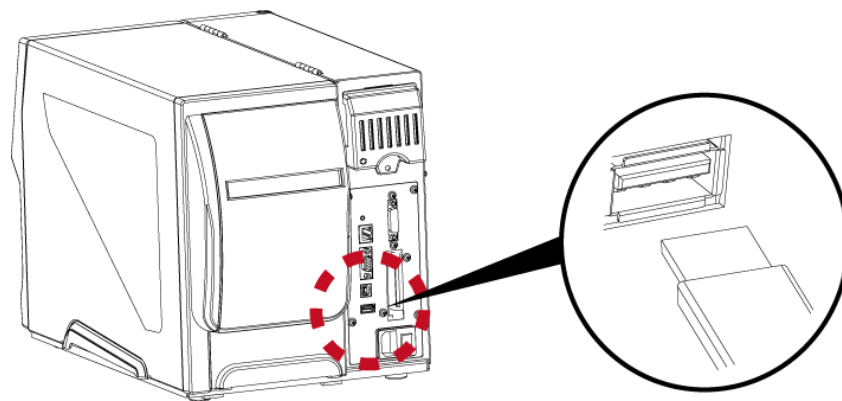

Usage of Firmware Update

- Remove USB memory stick from printer and plug-in it to a PC's USB port; delete Firmware "*.bin" file from "\LABELDIR\FW" of USB memory stick if it existing; or create a Folder "\LABELDIR\FW" to USB memory stick if it doesn't existing.
- Copy a new version of Firmware "xxxx.bin" to the Folder "\LABELDIR\FW"; and then remove USB and plug-in back to the printer that going to update Firmware.
- The printer will update the Firmware automatically when plug-it-into the printer and printer find-out the Firmware in "\LABELDIR\FW" is newer version.
- Don't remove the USB memory stick out while it's under updating with "Flash Writing..." message that displays on LCD panel.

USB Keyboard

When plug-in an USB keyboard to the printer, LCD touch panel will display “Enter Standalone”, press the “Y” key on keyboard to entering to the dialog for “Keyboard Mode” operation.

Here have six sub-dialogs “Recall Label” “Country Code” “Code Page” “Clock Setting” “Database Setting” “Label Edit” is able operating by keyboard as follow definition:

1. Press “ESC” key to exist from “Keyboard Mode” or back to previous dialog
2. Press “F1”, it will let the printer from “Home Page” mode entering into “Keyboard Mode”
3. Press “Enter”, “Arrow” and “Alphabetic” keys as the usual in PC that will perform the key-in function of “Keyboard Mode”.

Note

- * The USB Host port on GoDEX printer is without “HUB” function.
- * The USB Memory Stick supports with “FAT32” Disk Format and up to 32GB only. The certified venders are Transcend, Apacer, Patriot, Consair and Kingston.
- * The download function for Graphic, Font, Label Format, DBF and Command files is operated by GoLabel of PC and must go through the a “i” “x” model printer itself.
- * On a PC, user may copy entire folde “\LABELDIR” from USB memory stick to PC or vice-versa. Copy a sub-folder or individual file in “\LABELDIR” to PC or vice-versa is not supported.

4 NetSetting for Ethernet

4.1 Installing the NetSetting software

The NetSetting software is used to manage the network configurations when connecting the printer via Ethernet port.

It is available on product CD or can be downloaded from official website. To install the NetSetting, please follow below steps.

1. Insert the product CD in the CD/DVD drive of the host computer and open the "Ethernet" folder on the CD.
2. Select the icon for the NetSetting installation file and click it to start the installation.

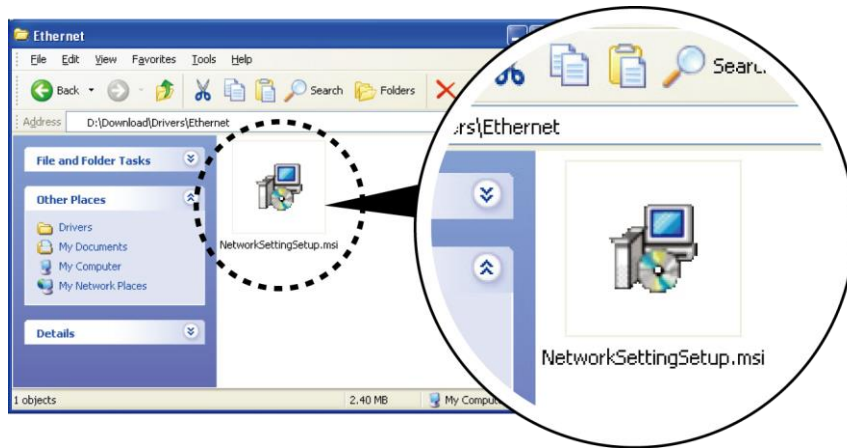

3. Follow the instructions on the screen. The Setup Wizard guides you through the installation procedure.
4. Specify the "Installation Folder".

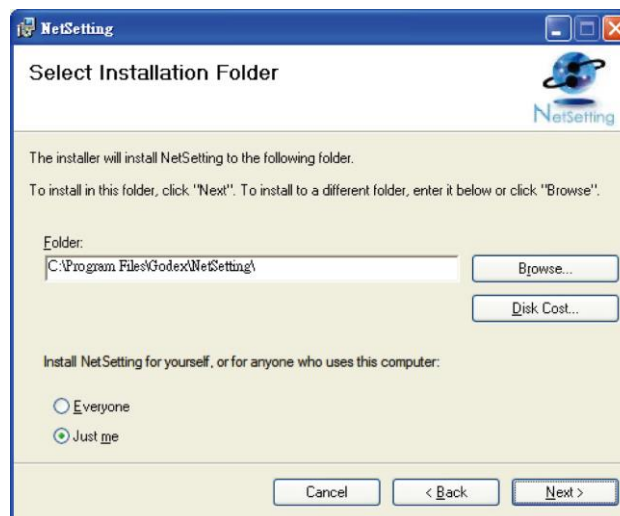

5. Click "Next" to start the installation.
6. Once the installation is completed; you will see the NetSetting icon on your desktop.



4.2 The interface of NetSetting

Click the NetSetting icon to start the program; you will see the start page as below. The start page will display the basic information of connected printer and your PC.

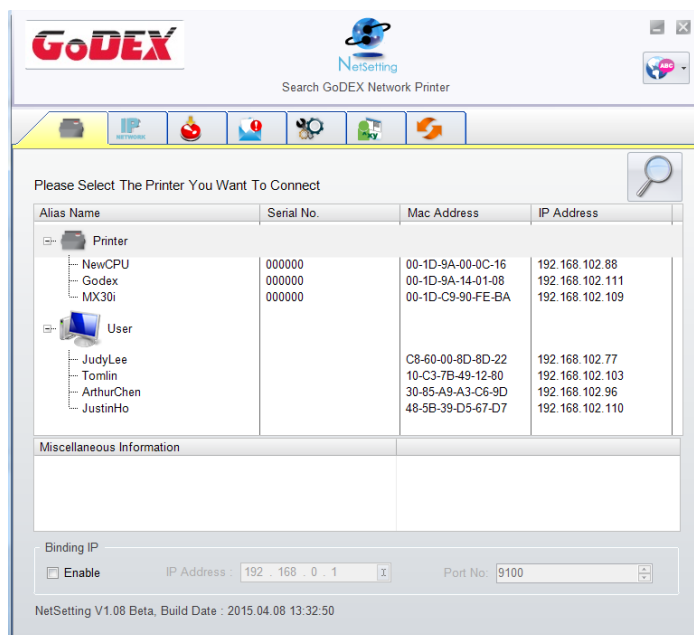

Click the magnifier icon to search the Godex printers which are connected via Ethernet port in you network environment. Once a connected Godex printer is detected, it will be listed on the start page.



There are six tabs on the top of interface which can configure different types of network settings. But for the data security reason, you need correct password to enter the configuration pages.

Notice

* The default password is "1111", you can change the password later from the "IP Setting" tab.

IP Setting

The IP Setting tab can change the printer name, Port number, Gateway setting and the password for configuring the printer. You can also set the printer's IP address either by DHCP or by Static IP.



The screenshot shows the 'IP Setting' window in the GoDEX NetSetting software. The window title is 'GoDEX NetSetting IP Setting'. The interface includes a toolbar with icons for printer, IP, home, help, settings, and refresh. The main area contains the following fields and options:

- Printer Name: Length(1-16)
- Port No:
- Default Gateway:
- Password: Length(1-4)
- Get IP From DHCP Server
- Static IP
- IP Address:
- Subnet Mask:

At the bottom, there are two buttons: 'Set' and 'Refresh'.

You can press "Set" button to apply the settings and "ReGet" button to refresh the setting values.

Notice

-
- * To fully benefit from the NetSetting software, you should be familiar with basic networking principles. Please contact your network administrator for related network setting information.
 - * When enabling DHCP, if you find the IP Address as: IP = 169.254.229.88, Netmask = 255.255.0.0, Gateway = invariable (last value), the IP Address is invalid.

Alert Path Setting

NetSetting will send the alert messages to designated mail account when the error happened on printer. The alert messages are sent by SMTP (Simple Mail Transfer Protocol) or SNMP (Simple Network Management Protocol).

You can set or change the configurations of SMTP and SNMP on this “Alert Path Setting” tab.

GoDEX NetSetting Alert Mail Setting

Enable SMTP Alert Message Notification

Login Account: default Length(1~64)
Login Password: ***** Length(1~16)
Server IP Address: 192 . 168 . 0 . 1 xxx.xxx.xxx.xxx
Mail Subject: Barcode printer message Length(1~60)
Mail From Address: default@default.com Length(1~32)
Mail To Address: default@default.com Length(1~32)
Duration Cycle: 1 0 ~ 168 Hours
Event Counter: 5 1 ~ 100

Enable SNMP Alert Message Notification

SNMP Community: public Length(1~16)
SNMP Trap Community: public Length(1~16)
Trap IP Address: 192 . 168 . 0 . 1 xxx.xxx.xxx.xxx

Set Refresh

You can press “Set” button to apply the settings and “ReGet” button to refresh the setting values.

Alert Message Setting

For the alert message notification function, you can decide which error cases need to be sent out to the operator.

Moreover, the alert messages can be set to be sent by SMTP, SNMP or both.

The screenshot displays the 'Alert Message Setting' window in the GoDEX NetSetting application. The window title is 'Alert Message Setting'. The interface includes a navigation bar with icons for printer, IP network, alert, settings, and refresh. The main content area features a table with three columns: 'SMTP', 'SNMP', and 'Description'. The 'SMTP' column contains unchecked checkboxes for all error types. The 'SNMP' column contains checked checkboxes for all error types. The 'Description' column lists the following error conditions: Paper or Ribbon Empty, Paper Jam, Ribbon Out, Printhead Up (Open), Rewinder Full, File System Full, File Not Found, Duplicated Name, Syntax Unknown, Cutter Jammed or Not Installed, and TPH Over Heat. At the bottom of the window, there are two buttons: 'Set' and 'Refresh'.

SMTP	SNMP	Description
<input type="checkbox"/>	<input checked="" type="checkbox"/>	Paper or Ribbon Empty
<input type="checkbox"/>	<input checked="" type="checkbox"/>	Paper Jam
<input type="checkbox"/>	<input checked="" type="checkbox"/>	Ribbon Out
<input type="checkbox"/>	<input checked="" type="checkbox"/>	Printhead Up (Open)
<input type="checkbox"/>	<input checked="" type="checkbox"/>	Rewinder Full
<input type="checkbox"/>	<input checked="" type="checkbox"/>	File System Full
<input type="checkbox"/>	<input checked="" type="checkbox"/>	File Not Found
<input type="checkbox"/>	<input checked="" type="checkbox"/>	Duplicated Name
<input type="checkbox"/>	<input checked="" type="checkbox"/>	Syntax Unknown
<input type="checkbox"/>	<input checked="" type="checkbox"/>	Cutter Jammed or Not Installed
<input type="checkbox"/>	<input checked="" type="checkbox"/>	TPH Over Heat

You can press "Set" button to apply the settings and "ReGet" button to refresh the setting values.

Printer Configuration

Set or change the configurations of connected printer. Most of key settings for the printer operation can be done by this setting page.

The screenshot shows the GoDEX NetSetting Printer Configuration web interface. The interface is titled "GoDEX NetSetting Printer Configuration" and features a navigation bar with icons for printer, network, and other settings. The main content area is divided into three sections: "Printer Setup", "Serial Port Setting", and "Miscellaneous".

Printer Setup

Printer Model	Tear-off Position	Speed	Darkness
ZX1200i+	12	2	12
Dispenser/Applicator	Labels per Cut	Printing Mode	
0 (None)	0	Thermal Transfer	

Serial Port Setting

Baud Rate	Parity	Data Bits	Stop Bits
4800	None	8	1

Miscellaneous

LCD Language	Sensing Mode
Traditional Chinese	0 - Reflective
Keyboard Country Code	Pre-Printing
US	OFF
Code Page	Top Of Form
Code Page 850	ON
Buzzer	
ON	

At the bottom of the interface, there are two buttons: "Set" and "Refresh".

You can press "Set" button to apply the settings and "ReGet" button to refresh the setting values.

User Command

The "User Command" tab provides a communication interface for operator to control the printer. Input printer commands in "Input Command" window and press "Send Command" button, the commands will be sent to the printer.

For some commands that will return response message, the message will be displayed in "Output Message" window.

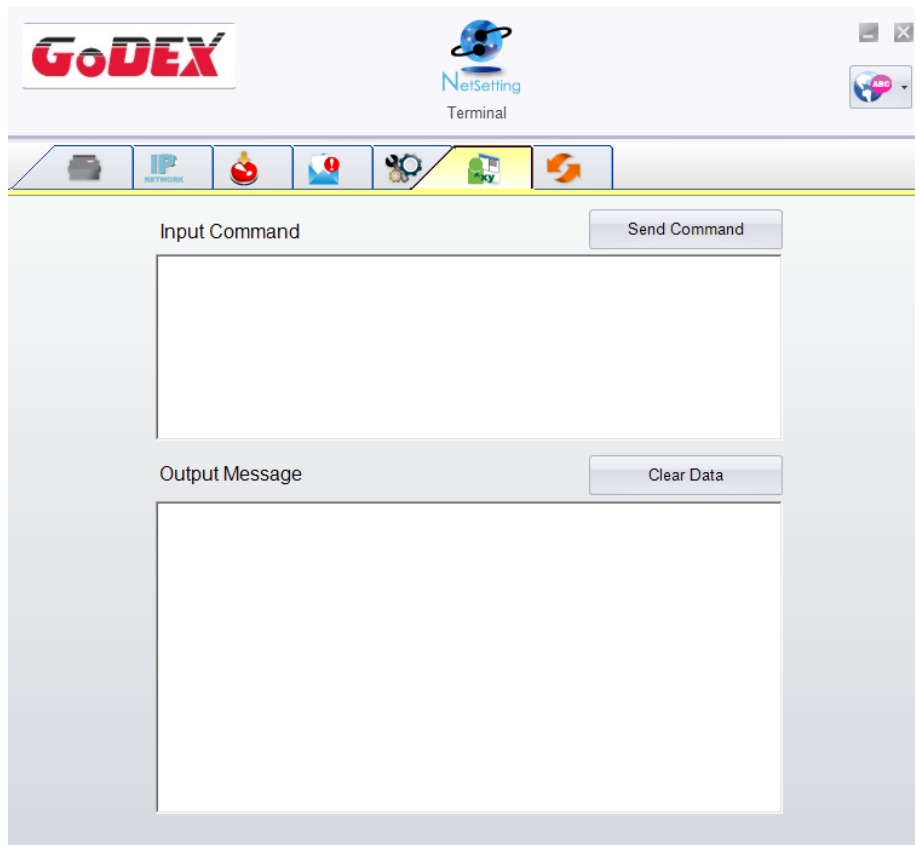

You can press "Send Command" button to send printer commands via Ethernet port and control the printer remotely.

Firmware Download

On "Firmware Download" tab, the current version of printer firmware will be showed on the screen. If you need to update the printer firmware, just specify the file location of firmware file and press "Start Download Firmware" button.

The printer firmware then can be updated remotely.

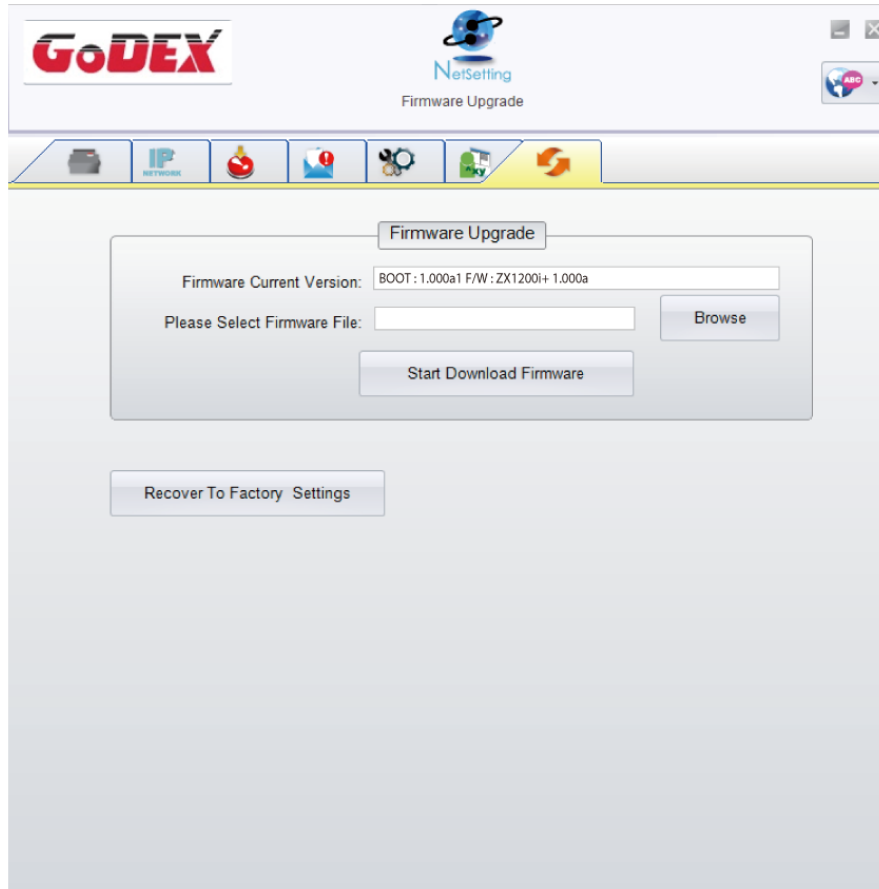

In addition to the firmware update, you can press "Recover to Factory Settings" button to restore the printer configurations back to factory default.

5 Preparation Steps

5.1 Preparation steps

Before installing the optional modules, please make some preparations as follows.

1. Turn off the printer:
Remember to switch off the printer before installing any module
2. Open the printer cover

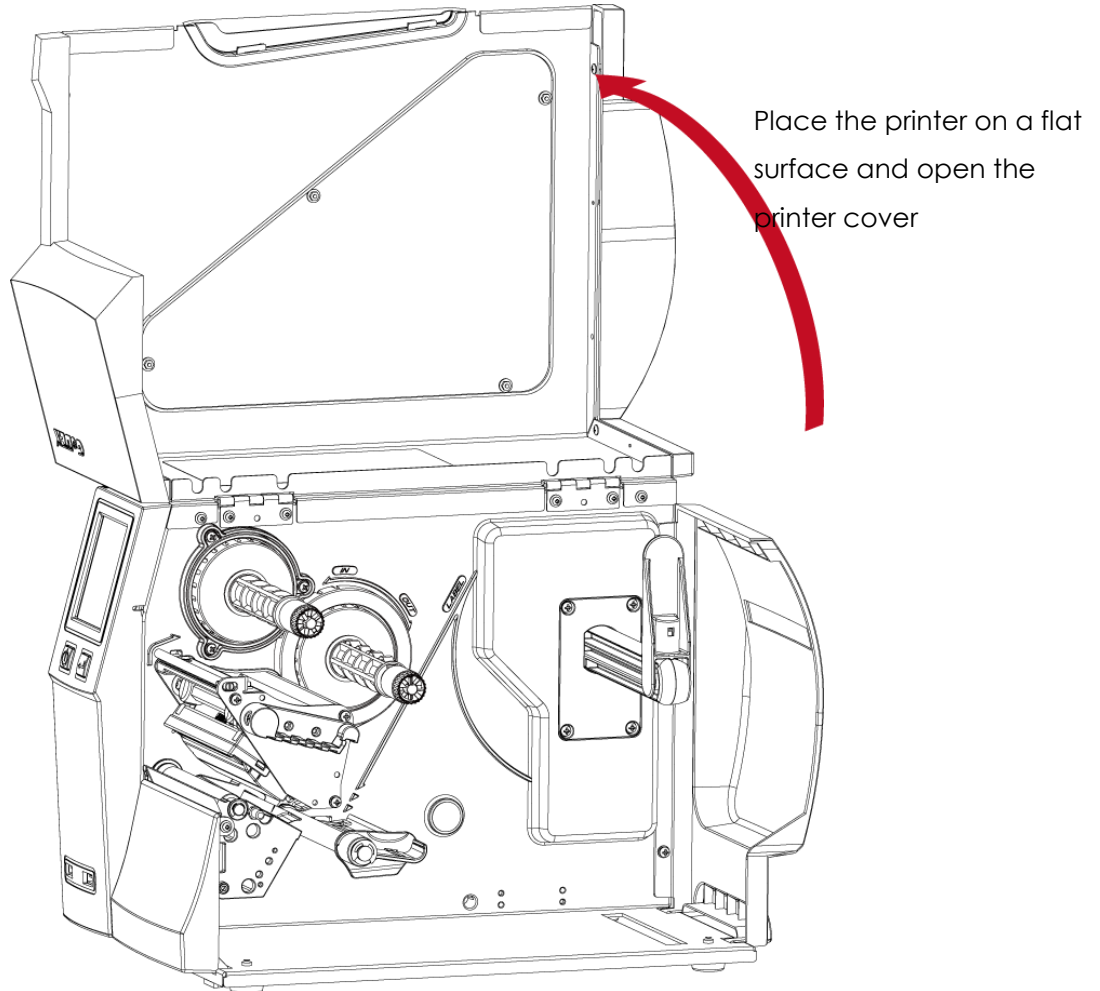

Notice

* Remember to switch off the printer before installing the cutter.

* Do not use to cut adhesive labels! Glue residue will be left on the cutter blade and impair its functioning.

* Under the ordinary paper application condition, the cutter performs 300000 cuts of a heavy paper with up to 250 μm thick or 100000 cuts of a plastic sheet with up to 300 μm thick.

5.2 Installing the cutter

The Overview of the Cutter

1. Cutter module
2. Screw

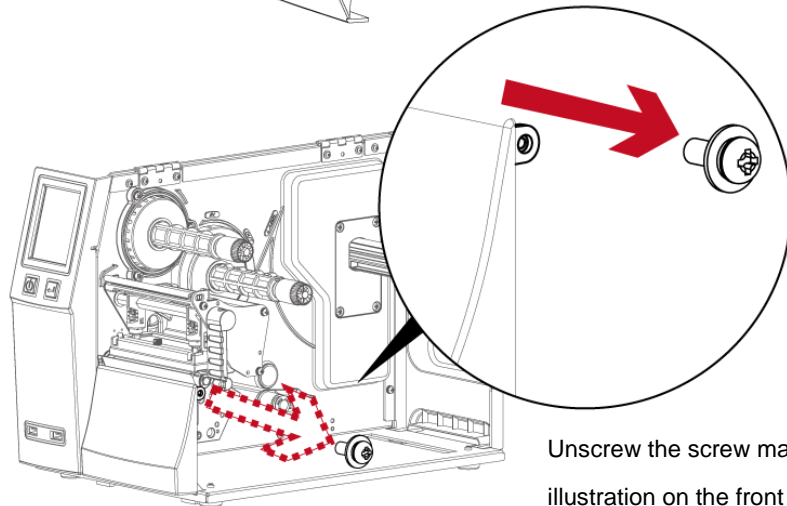
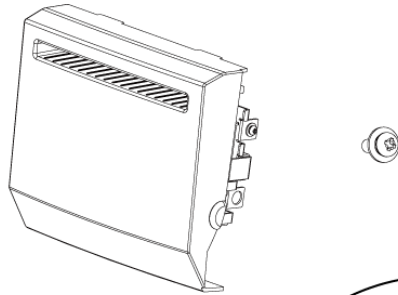

Unscrew the screw marked in the illustration on the front of the printer, which secures the lower cover plate.

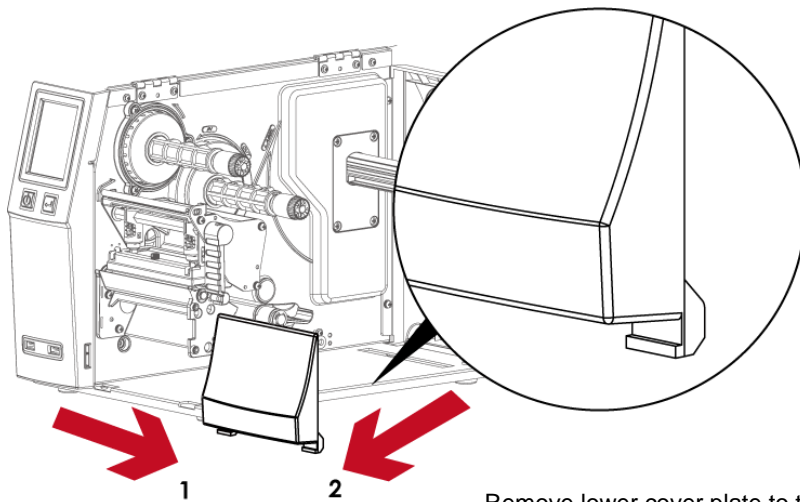

Remove lower cover plate to the a little bit right then can get out.

Connect the cutter cable connector to the cutter jack on the printer.

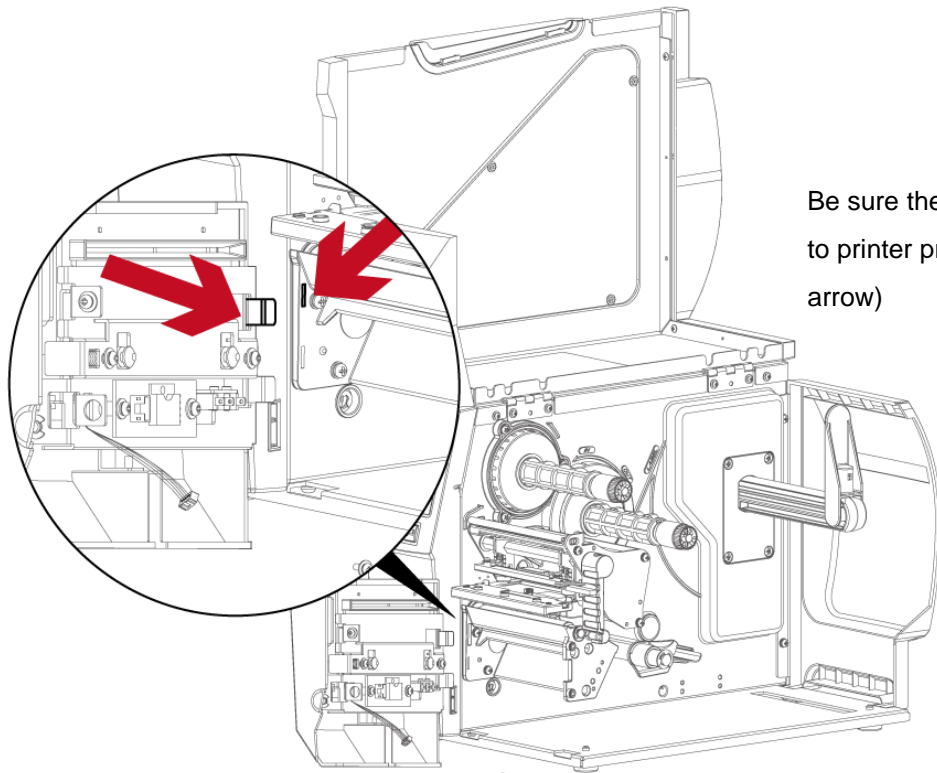
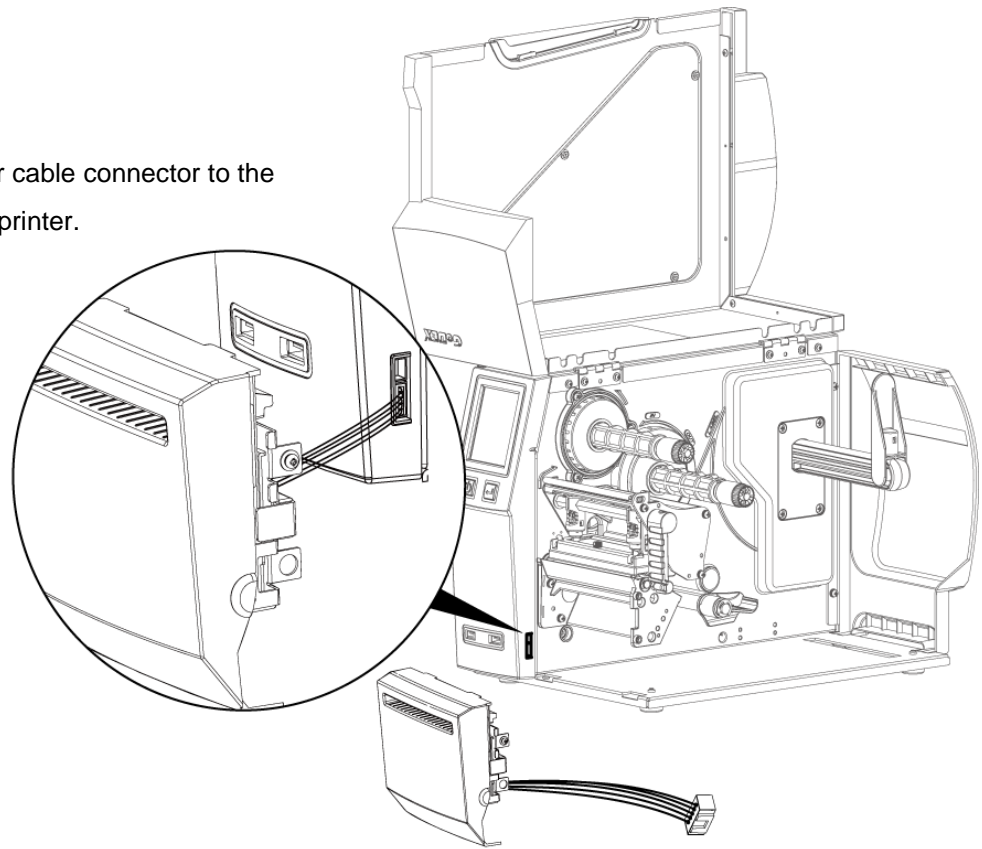

Be sure the cutter module insert to printer properly. (see red arrow)

Secure the cutter module on the printer housing using the screws.

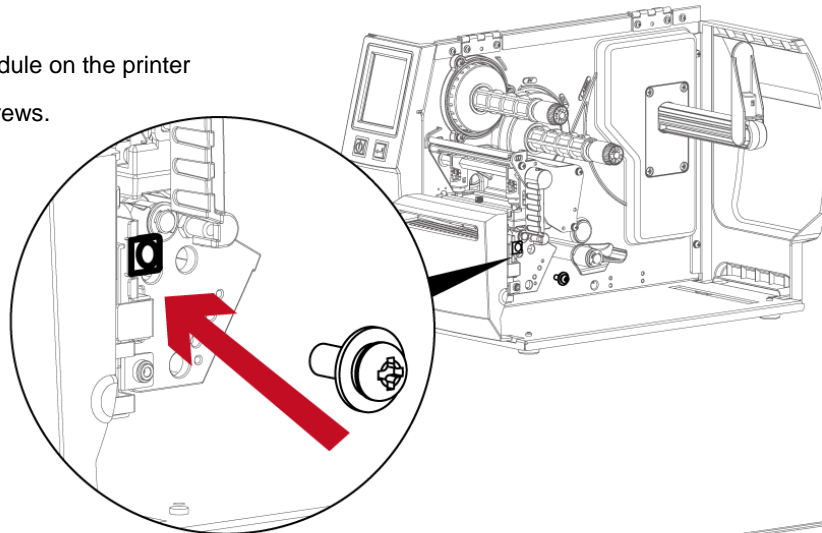

Finish the cutter module installed.

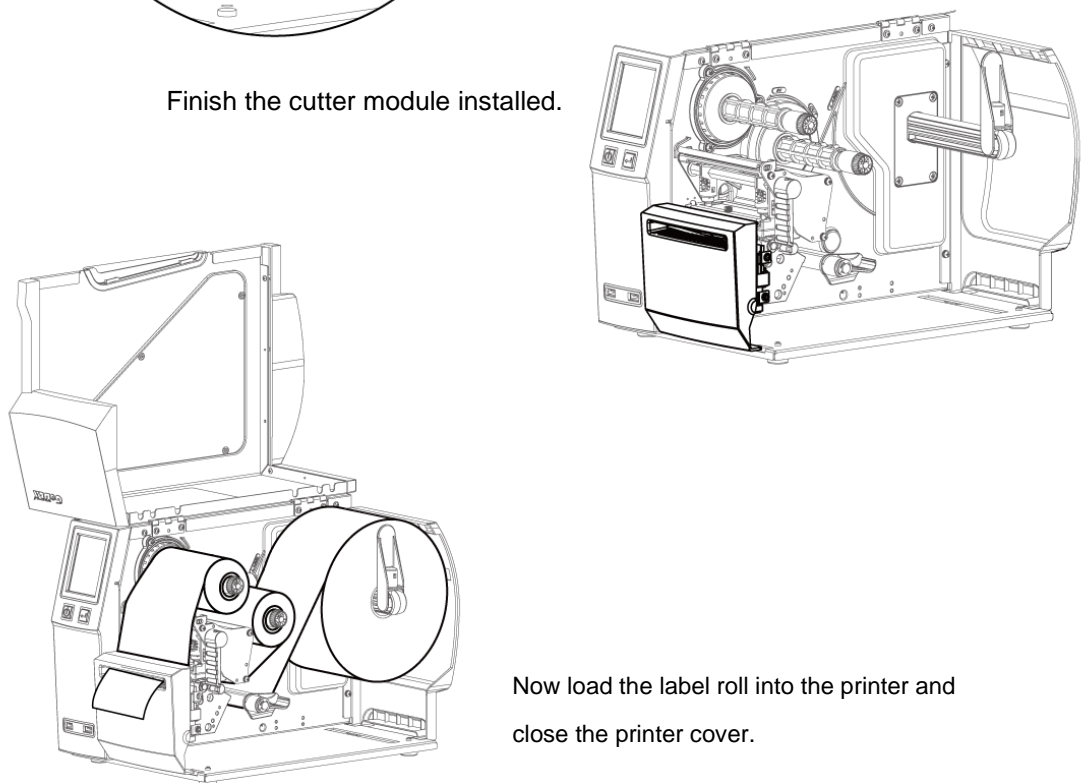

Now load the label roll into the printer and close the printer cover.

Notice

- * Check whether the cutter function is enabled in the printer.
- * Labels or paper should be at least 30 mm high.
- * After installation of the cutter module, set the stop position (^E) to 30.

6 Maintenance and Adjustment

6.1 Installing / removing the print head module

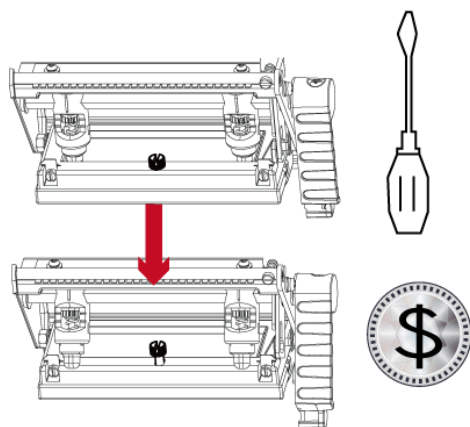

Open the printer cover.

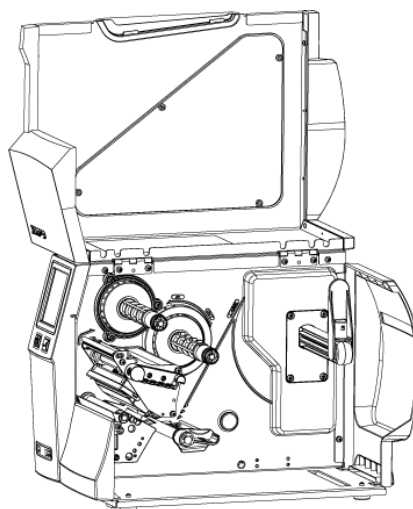

using a screwdriver or a coin,
loosen the screw to take out
the TPH module.

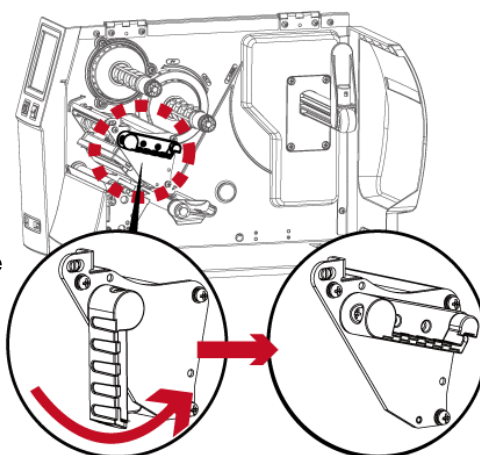

Turn the print head counterclockwise
to a top right position

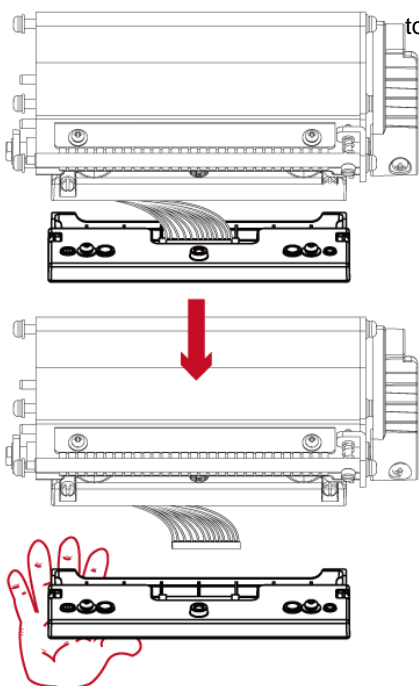

Hold the print head module, pull out the TPH
cable smoothly.

To install TPH module, follow the reverse
order.

Notice

* Remember to switch off the printer before removing the print head module.

6.2 Adjusting the print line

Open the printer cover.

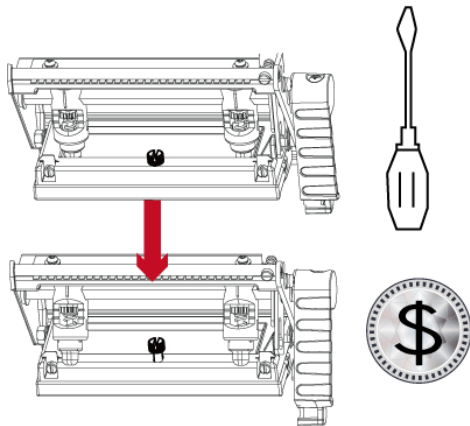
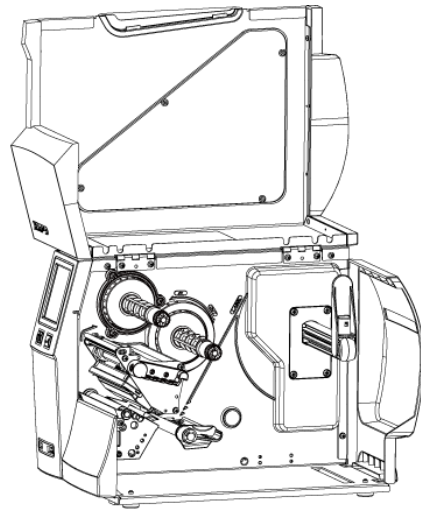

using a screwdriver or a coin to loosen the screw

Turn the print head counterclockwise to a top right position

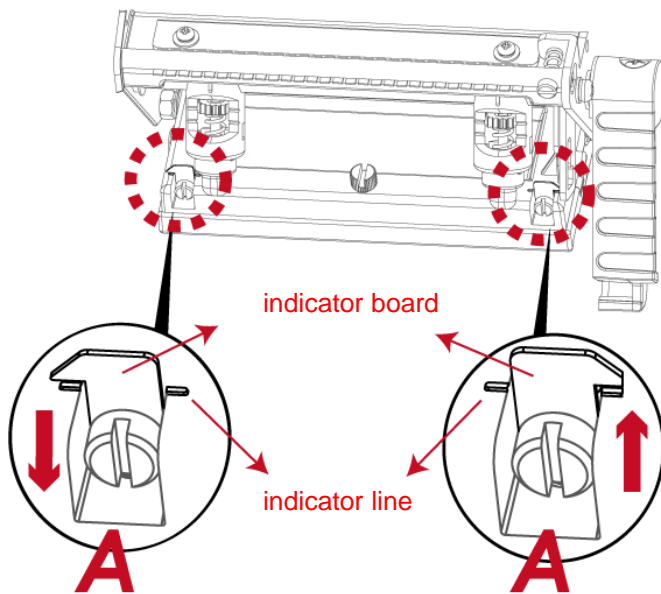
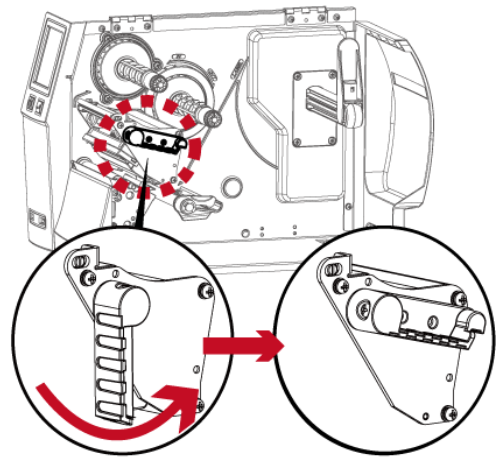

If no improvement is visible, turn the screws(A) clockwise or counterclockwise as far as possible and be sure to align with the indicator board and indicator line.

Repeat the adjustment process until printing quality has improved.

6.3 Adjusting ribbon tension

You can adjust the ribbon tension by turning the ribbon shaft knob (see illustration) clockwise or counterclockwise.

There are 4 possible settings, which is marked on the ribbon supply hub.

1 : Tension is the highest

4 : Tension is the lowest

If the tension is so low that the ribbon does not move forward, you need to reduce the tension of the ribbon supply hub.

To set the tension, press in the knob and turn it clockwise or counterclockwise as required.

Increasing the tension of the ribbon rewind hub will remove any wrinkling of the ribbon during printing, which results from the use of different ribbon materials. (For details about the wrinkling/creasing of ribbons, see Section 6-6.)

If you are using a very narrow ribbon, the printer may not move the label stock forward (particularly with a ribbon that is less than 2" wide). In that case, reduce the tension by turning the knob of the ribbon supply hub counterclockwise.

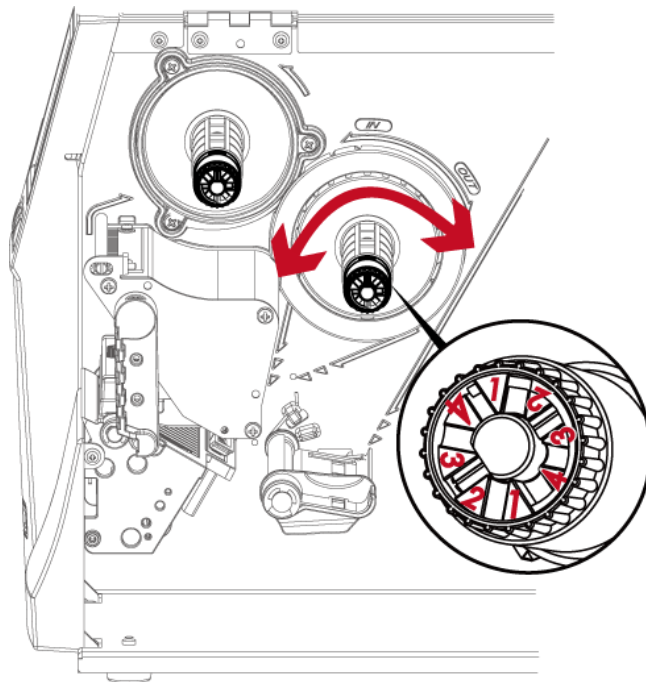

6.4 Cleaning the thermal print head

Dirt on the print head or ribbon may result in inadequate print quality (there are only partial images on the label). The printer cover should therefore be kept closed when possible.

Keeping dirt and dust away from the paper or labels ensures a good print quality and a longer lifespan of the print head. Here is how you clean the print head:

1. Switch off the printer.
2. Open the printer cover.
3. Remove the ribbon.
4. Release the print head by turning the print head release lever.
5. To remove any label residue or other dirt from the print head (see Red arrow), please use a soft lint-free cloth dipped in alcohol to wipe.

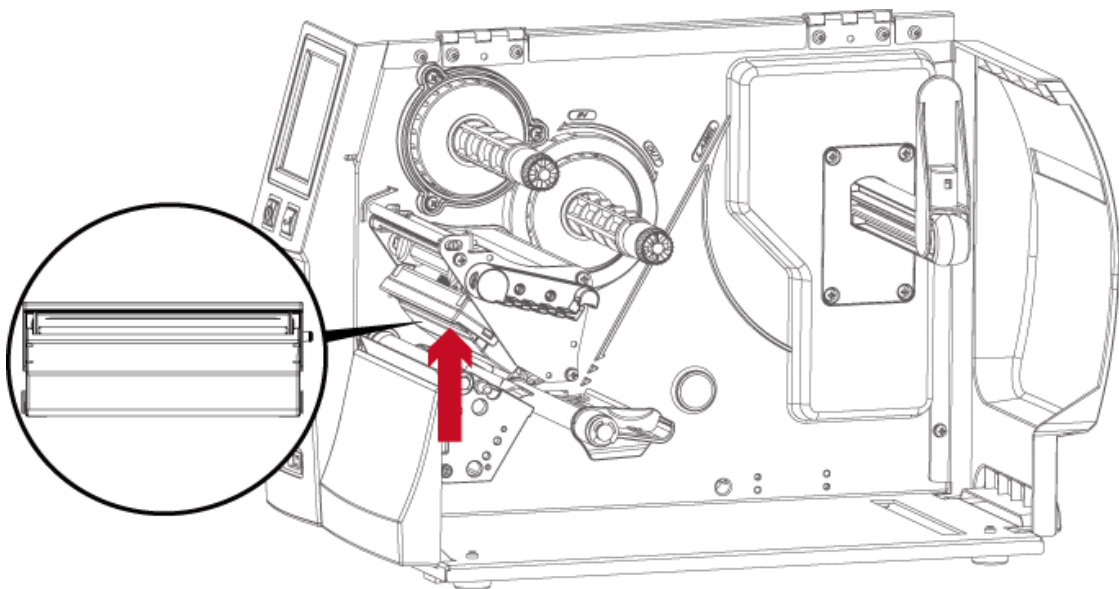

Note

* The print head should be cleaned once a week.

* Please make sure that there are no metal fragments or other hard particles on the soft cloth used to clean the print head.

6.5 Adjusting the balance and print head tension

Open the printer cover.

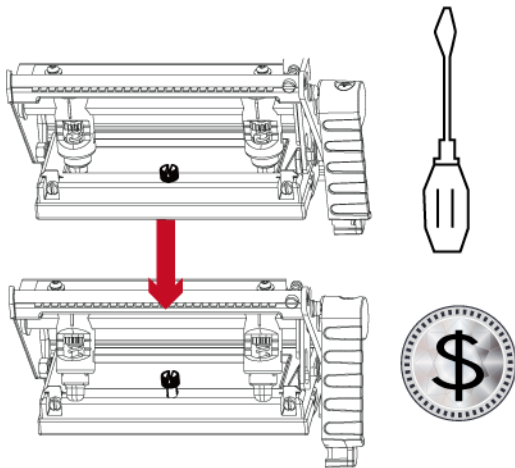
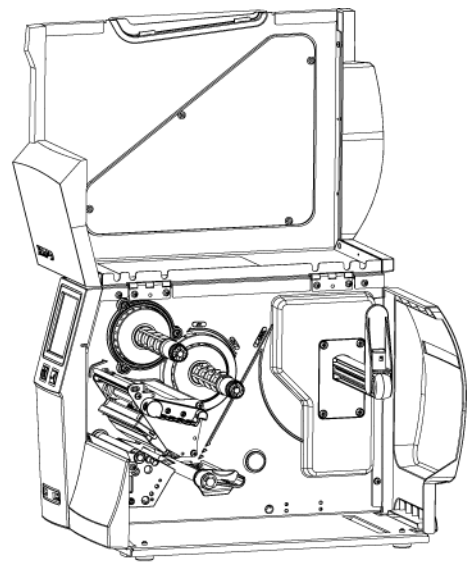

using a screwdriver or a coin to
loosen the screw

When using a variety of label stock and ribbons, the ink may not be evenly distributed.

If there is no printed image on one side of the paper, or the ribbon wrinkles, the print head pressure must be readjusted using the TPH spring boxes.

Move the TPH spring boxes as shown in the illustration to change the print head pressure.

The wider the label you are using, the further apart the TPH spring boxes must be moved away from each other. If there is no quality improvement, you need to change the pressure on the TPH spring boxes.

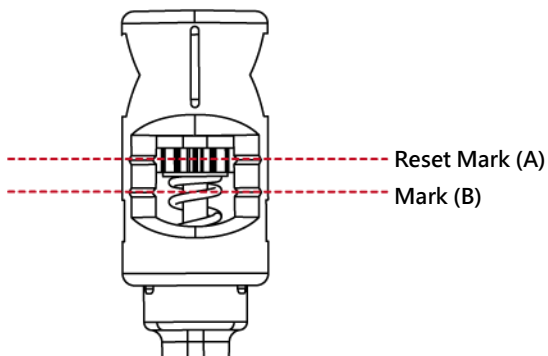
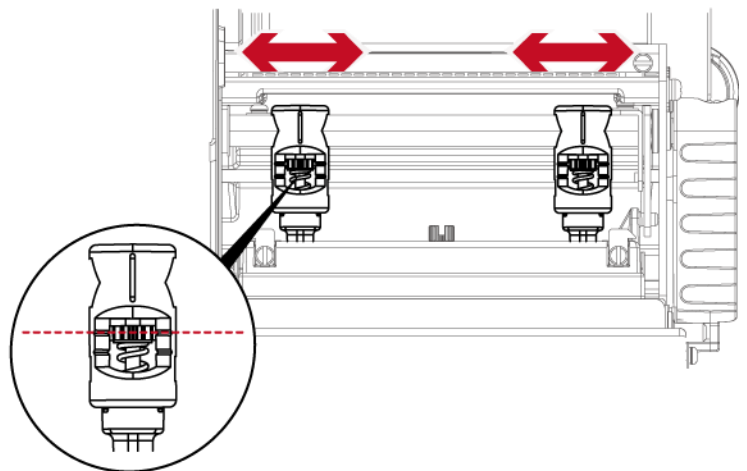

Turning the screw left increases the pressure, while turning it right reduces the pressure. Be sure not to turn the screw so that it goes below Mark(B).

6.6 Ribbon shield settings

The use of different ribbon materials may cause wrinkling of the ribbon, which in turn affects the print result as illustrated by the examples in (a) and (b).

To change the print quality, you can adjust the ribbon shield screws.

If your print result looks like the example in (a), you need to turn ribbon shield screw counterclockwise.

If your print result looks like the example in (b), you need to turn ribbon shield screw clockwise.



To keep track of the change in print quality, you should adjust the screws by half a turn at a time.

Print a test page. If there is no improvement in the print result, turn the screw by another half turn.

Do not turn the adjustment screw more than two full turns(360°).

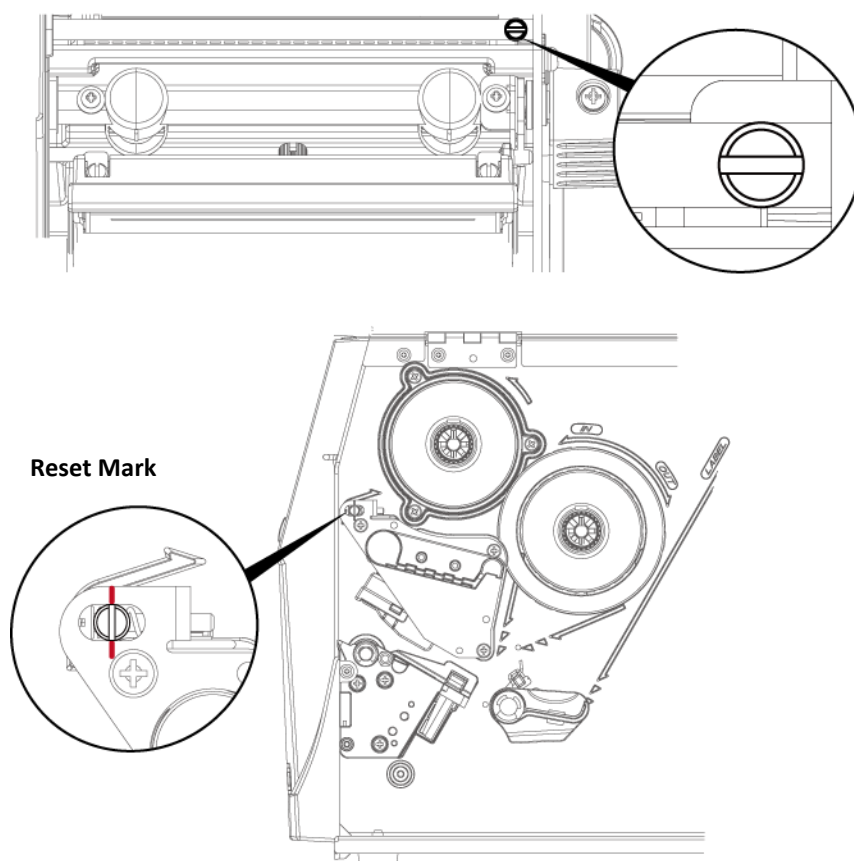

Note

* If you adjust the screw by more than two full turns, the paper feed may no longer function correctly. In that case, unscrew the ribbon shield screws to align the reset mark and restart the adjustment process.

6.7 Cutter settings

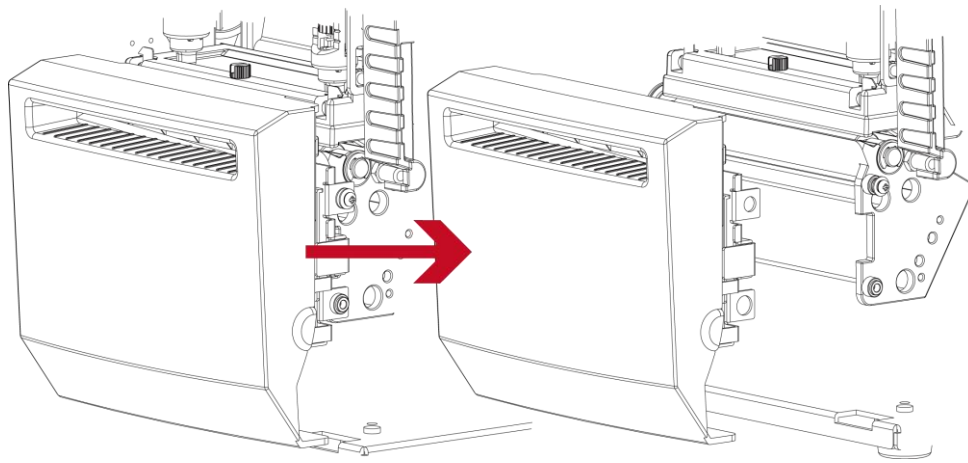

Switch off the printer before removing the cutter.

(Remove or install cutter refer to “accessories” in Section 5)

Unscrew the screw at the bottom of cutter.

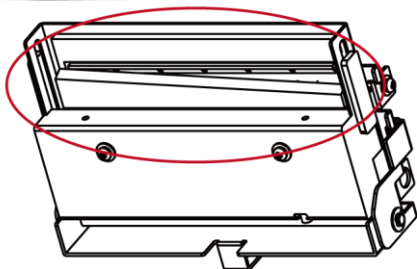
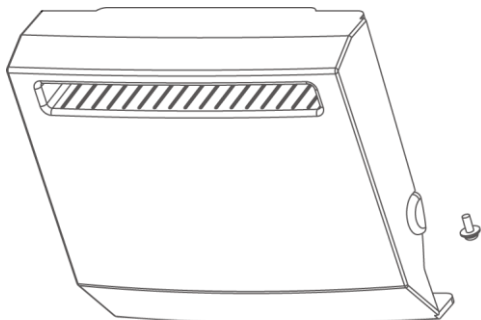
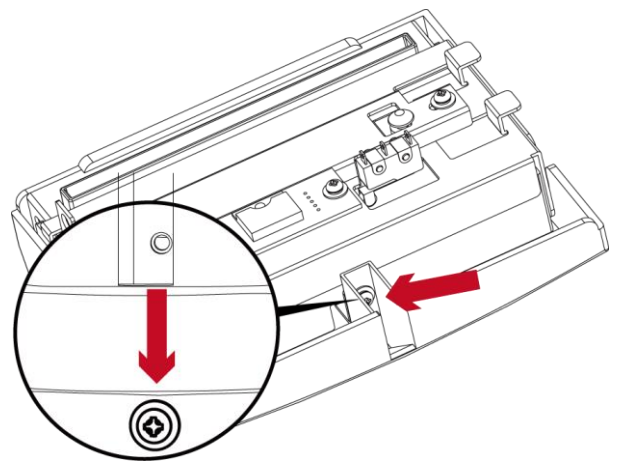

Remove the cutter cover.

Clean and remove jammed paper.

Reinstall CUTTER back onto printer.

Note

* Remember to switch off the printer before removing the CUTTER.

* The label medium should be at least 30 mm long to ensure correct functioning of the cutter.

6.8 Troubleshooting

Problem	Solution
The printer is switched on but the LED does not light up.	◆ Check the power supply. Please see the Section 2.4
The LED lights up red and printing is interrupted.	◆ Check the software settings (driver settings) or command codes. ◆ Look for the error alert in the table in Section 3.3. Error Alerts. ◆ Check whether the print mechanism is closed correctly. Please see the Section 3.3
The label stock passes through the printer but no image is printed.	◆ Please make sure that the label stock is loaded the right side up and that it is the suitable material. ◆ Choose the correct printer driver. ◆ Choose the correct label stock and a suitable printing mode.
The label stock jams during printing.	◆ Clear the paper jam. Remove any label material left on the thermal print head and clean the print head using a soft lint-free cloth dipped in alcohol. Please see the Section 6.1
There is no printed image on some parts of the label.	◆ Check whether there is any label material or ribbon stuck to the thermal print head. ◆ Check for errors in the application software. ◆ Check whether the starting position has been set correctly. ◆ Check the ribbon for wrinkles.
There is no printed image on part of the label or the image is blurred.	◆ Check the thermal print head for dust or other dirt. ◆ Use the internal “~T” command to check whether the thermal print head will carry out a complete print job. ◆ Check the quality of the print medium.
The printed image is positioned incorrectly.	◆ Check whether there is paper or dust covering the sensor. ◆ Check whether the label stock is suitable. Contact your supplier. ◆ Check the paper guide settings.
Skipping labels during printing.	◆ Check the label height setting. ◆ Check whether there is dust covering the sensor. ◆ Run the auto-detection function. Please see the Section 3.2
The printed image is blurred.	◆ Check the darkness setting. ◆ Check the thermal print head for dust or dirt. Please see the Section 6.1
The cutter does not cut off the labels in a straight line	◆ Check whether the label stock is positioned straight.
The cutter does not cut off the labels completely.	◆ Check whether the label is more than 0.2 mm thick.
When using the cutter, the labels are not fed through or cut off incorrectly.	◆ Check whether the cutter has been correctly installed. ◆ Check whether the paper guides are functioning correctly.
The label dispenser is not functioning normally.	◆ Check whether there is dust on the label dispenser. ◆ Check whether the label stock is positioned correctly.

Note

* If any problems occur that are not described above, please contact your dealer.

APPENDIX — Product Specifications

Model Name		ZX1200i+	ZX1300i+	ZX1600i+
Print Method		Thermal Transfer / Direct Thermal		
Resolution		203 dpi (8 dots/mm)	300 dpi (12 dot/mm)	600 dpi (24 dots/mm)
Print Speed		Up to 10 IPS (254 mm/s)	Up to 7 IPS (178 mm/s)	Up to 4 IPS (102 mm/s)
Print Width		4.09" (104 mm, up to 108 mm)	4.09" (104 mm, up to 105.7 mm)	4.09" (104 mm, up to 105.6 mm)
Print Length		Min. 0.16" (4 mm)**; Max. 279.53" (7100 mm)	Min. 0.16" (4 mm)**; Max. 125.98" (3200 mm)	Min. 0.16" (4 mm) Max. 31.5" (800 mm)
Processor		32-bit RISC CPU		
Memory	Flash	256 MB		
	SDRAM	256 MB		
Sensor Type		Adjustable reflective sensor and transmissive sensor, left aligned		
Media	Type	Continuous form, gap labels, black mark sensing, and punched hole; label length set by auto sensing or programming		
	Width	Tear : Min. 1" (25.4 mm) – Max. 4.65" (118 mm) Cutter : Max. 4.61" (117 mm) Dispenser : Max. 4.65" (118 mm)		
	Thickness	Min. 0.0024" (0.06 mm) – Max. 0.01" (0.25 mm)		
	Label roll diameter	Max. 8" (203.2 mm)		
	Core diameter	Min. 1.5" (38.1 mm) – Max. 3" (76.2 mm)		
Ribbon	Types	Wax, wax/resin, resin		
	Length	Max. 1476' (450 m)		
	Width	Min. 1.18" (30 mm) – Max. 4.33" (110 mm)		
	Ribbon roll diameter	3" (76.2 mm)		
Core diameter		1" (25.4 mm)		
Printer Language		EZPL, GEPL, GZPL, GDPL auto switch		
Software	Label design tool	GoLabel II (for EZPL only)(Windows)		
	Management tools	GoTools (Windows/ Android) GoUtility (Windows) GoAPP (Android/ iOS)		
	APP	Windows 7, Windows 8 & 8.1, Windows 10, Window11, Windows Server 2008 R2, 2012, 2012 R2, 2016, 2019, 2022, MAC, Linux		
Driver		Windows 7, Windows 8 & 8.1, Windows 10, Window11, Windows Server 2008 R2, 2012, 2012 R2, 2016, 2019, 2022, MAC, Linux		
SDK		Win CE, .NET, Windows 7, Windows 8 & 8.1, Windows 10, Windows 11, Android, Mac, iOS		
Resident Fonts	Bitmap Fonts	6, 8, 10, 12, 14, 18, 24, 30, 16X26 and OCR A & B 0°, 90°, 180°, 270° rotatable, single characters 0°, 90°, 180°, 270° rotatable 8 times expandable in horizontal and vertical directions		
	TTF Fonts	(Bold / Italic / Underline) 0°, 90°, 180°, 270° rotatable Internal TTF Fonts x5 : Traditional Chinese, Simplified Chinese, Japanese, Korean, Western languages		
Download Fonts	Bitmap Fonts	0°, 90°, 180°, 270° rotatable, single characters 0°, 90°, 180°, 270° rotatable		
	Asian Fonts	16x16, 24x24. Traditional Chinese (BIG-5), Simplified Chinese(GB2312), Japanese (S-JIS), Korean (KS-X1001)		
	TTF Fonts	0°, 90°, 180°, 270° rotatable and 8 times expandable in horizontal and vertical directions (Bold / Italic / Underline) 0°, 90°, 180°, 270° rotatable		
Barcodes	1-D Bar Codes	China Postal Code, Codabar, Code 11, Code 32, Code 39, Code 93, Code 128 (subset A, B, C), EAN-8/EAN-13 (with 2 & 5 digits extension), EAN 128, FIM, German Post Code, GS1 DataBar, HIBC, Industrial 2 of 5, Interleaved 2-of-5 (1 2 of 5), Interleaved 2-of-5 with Shipping Bearer Bars, ISBT-128, ITF 14, Japanese Postnet, Logmars, MSI, Postnet, Plessey, Planet 11 & 13 digit, RPS 128, Standard 2 of 5, Telepen, Matrix 2 of 5, UPC-A/UPC-E (with 2 or 5 digit extension), UCC/EAN-128 K-Mart, Random Weight and Pharmacode		
	2-D Bar Codes	Aztec code, Code 49, Codablock F, Datamatrix code, MaxiCode, Micro PDF417, Micro QR code, PDF417, QR code, TLC 39, GS1 Composite, DotCode, Marco PDF 417		
Code Pages		Codepage 437, 737, 850, 851, 852, 855, 857, 860, 861, 862, 863, 865, 866, 869 Windows 1250, 1251, 1252, 1253, 1254, 1255, 1257 Unicode UTF8, UTF16BE, UTF16LE		
Graphics		Resident graphic file types are BMP and PCX, other graphic formats are downloadable from the software USB 2.0 (Type B)		
Interfaces		Serial Port (RS-232) Ethernet 10/100 Mbps 3 USB Host (Type A), 2 ports at the front panel, 1 port at the rear panel		
Control Panel		Backlight 3.2" touch screen LCD 1 Power on/off button with green color LED backlight 1 Control key: FEED/PAUSE/CANCEL with dual color LED backlight: Ready(Green); Error(Red) 1 Calibration button at rear panel		
Real Time Clock		Standard		
Power		Auto Switching 100-240V AC, 50-60Hz		
Environment	Operation temperature	41°F to 104°F (5°C to 40°C)		
	Storage temperature	-4°F to 140°F (-20°C to 60°C)		
Humidity	Operation	20-85%, non-condensing		
	Storage	10-90%, non-condensing		
Agency Approvals		CE (EMC), FCC Class B, CB, cULus, ICES-003, UKCA, BSMI (The safety certification marks may be different depending on sales regions.)		
Dimension	Length	465 mm (18.3")		
	Width	269 mm (10.6")		
	Height	312 mm (12.3")		
	Weight	13.6 Kg (30 lbs), excluding consumables		
Options	Cutter module (User Install) – Rotary cutter, Guillotine cutter, Perforation cutter, High speed cutter, Paper card cutter			
	Parallel port adaptor module (Centronic female 36-pin)(Dealer Install)			
	WiFi and BT (BLE 5.0) combo module (Dealer Install)			
	External label rewriter			
	Label Dispenser + Internal rewriter module (Dealer Install)			
	Applicator Interface (DSUB female 15-pin) External label unwinder RFID R/W module (project option)			

Model Name		ZX1200Xi+	ZX1300Xi+
Print Method		Thermal Transfer / Direct Thermal	
Resolution		203 dpi (8 dots/mm)	300 dpi (12 dot/mm)
Print Speed		Up to 14 ips (356 mm/s)	Up to 10 ips (254 mm/s)
Print Width		4.09" (104 mm)	4.09" (104 mm, up to 105.7 mm)
Print Length		Min. 0.16" (4 mm)**; Max. 279.53" (7100 mm)	Min. 0.16" (4 mm)**; Max. 125.98" (3200 mm)
Processor		32-bit RISC CPU	
Memory	Flash	256 MB	
	SDRAM	256 MB	
Sensor Type		Adjustable reflective sensor and transmissive sensor, left aligned	
Media	Type	Continuous form, gap labels, black mark sensing, and punched hole; label length set by auto sensing or programming	
	Width	Tear : Min. 1" (25.4 mm) – Max. 4.65" (118 mm) Cutter : Max. 4.61" (117 mm) Dispenser : Max. 4.65" (118 mm)	
	Thickness	Min. 0.0024" (0.06 mm) – Max. 0.01" (0.25 mm)	
	Label roll diameter	Max. 8" (203.2 mm)	
	Core diameter	Min. 1.5" (38.1 mm) – Max. 3" (76.2 mm)	
Ribbon	Types	Wax, wax/resin, resin	
	Length	Max. 1476' (450 m)	
	Width	Min. 1.18" (30 mm) – Max. 4.33" (110 mm)	
	Ribbon roll diameter	3" (76.2 mm)	
Printer Language	Core diameter	1" (25.4 mm)	
	Label design tool Management tools APP	EZPL, GEPL, GZPL, GDPL auto switch GoLabel II (for EZPL only) (Windows) GoTools (Windows / Android) GoUtility (Windows) GoAPP (Android/ iOS)	
Driver	Windows 7, Windows 8 & 8.1, Windows 10, Windows 11, Windows Server 2008 R2, 2012, 2012 R2, 2016, 2019, 2022, MAC, Linux		
SDK	Win CE, .NET, Windows 7, Windows 8 & 8.1, Windows 10, Windows 11, Android, Mac, iOS		
Resident Fonts	Bitmap Fonts	6, 8, 10, 12, 14, 18, 24, 30, 16X26 and OCR A & B 0°, 90°, 180°, 270° rotatable, single characters 0°, 90°, 180°, 270° rotatable 8 times expandable in horizontal and vertical directions	
	TTF Fonts	(Bold / Italic / Underline) 0°, 90°, 180°, 270° rotatable Internal TTF Fonts x5 : Traditional Chinese, Simplified Chinese, Japanese, Korean, Western languages	
Download Fonts	Bitmap Fonts	0°, 90°, 180°, 270° rotatable, single characters 0°, 90°, 180°, 270° rotatable 16x16, 24x24. Traditional Chinese (BIG-5), Simplified Chinese(GB2312), Japanese (S-JIS), Korean (KS-X1001)	
	Asian Fonts	0°, 90°, 180°, 270° rotatable and 8 times expandable in horizontal and vertical directions	
Barcodes	TTF Fonts	(Bold / Italic / Underline) 0°, 90°, 180°, 270° rotatable	
	1-D Bar Codes	China Postal Code, Codabar, Code 11, Code 32, Code 39, Code 93, Code 128 (subset A, B, C), EAN-8/EAN-13 (with 2 & 5 digits extension), EAN 128, FIM, German Post Code, GS1 DataBar, HIBC, Industrial 2 of 5, Interleaved 2-of-5 (1 2 of 5), Interleaved 2-of-5 with Shipping Bearer Bars, ISBT-128, ITF 14, Japanese Postnet, Logmars, MSI, Postnet, Plessey, Planet 11 & 13 digit, RPS 128, Standard 2 of 5, Telepen, Matrix 2 of 5, UPC-A/UPC-E (with 2 or 5 digit extension), UCC/EAN-128 K-Mart, Random Weight and Pharmacode	
	2-D Bar Codes	Aztec code, Code 49, Codablock F, Datamatrix code, MaxiCode, Micro PDF417, Micro QR code, PDF417, QR code, TLC 39, GS1 Composite, DotCode, Marco PDF 417	
Code Pages	Codepage 437, 737, 850, 851, 852, 855, 857, 860, 861, 862, 863, 865, 866, 869 Windows 1250, 1251, 1252, 1253, 1254, 1255, 1257 Unicode UTF8, UTF16BE, UTF16LE		
Graphics	Resident graphic file types are BMP and PCX, other graphic formats are downloadable from the software USB 2.0 (Type B)		
Interfaces	Serial Port (RS-232)		
	Ethernet 10/100 Mbps 3 USB Host (Type A). 2 ports at the front panel, 1 port at the rear panel		
Control Panel	Backlight 3.2" touch screen LCD 1 Power on/off button with green colour LED backlight 1 Control key: FEED/PAUSE/CANCEL with dual colour LED backlight: Ready(Green); Error(Red) 1 Calibration button at rear panel		
Real Time Clock	Standard		
Power	Auto Switching 100-240V AC, 50-60Hz		
Environment	Operation temperature	41°F to 104°F (5°C to 40°C)	
	Storage temperature	-4°F to 140°F (-20°C to 60°C)	
Humidity	Operation	20-85%, non-condensing	
	Storage	10-90%, non-condensing	
Agency Approvals	CE (EMC), FCC Class B, CB, cULus, ICES-003, UKCA, BSMI (The safety certification marks may be different depending on sales regions.)		
Dimension	Length	465 mm (18.3")	
	Width	269 mm (10.6")	
	Height	312 mm (12.3")	
	Weight	13.6 Kg (30 lbs), excluding consumables	
Options	Cutter module (User Install) – Rotary cutter, Guillotine cutter, Perforation cutter, High speed cutter, Paper card cutter		
	Parallel port adaptor module (Centronic female 36-pin)(Dealer Install)		
	WiFi and BT (BLE 5.0) combo module (Dealer Install)		
	Applicator Interface (DSUB female 15-pin)		
	External label rewinder Label Dispenser + Internal Rewinder (Dealer Install)		

* Specifications are subject to change without notice. All company and/or product names are trademarks and/or registered trademarks of their respective owners.

** Minimum print height and maximum print speed specification compliance can be dependent on non-standard material variables such as label type, thickness, spacing, liner construction, etc. Godex is pleased to test non-standard materials for minimum print height, and maximum print speed capability.

*** The safety certification marks may be different depending on sales regions.

Notice

* Specifications are subject to change without notice. All company and/or product names are trademarks and/or registered trademarks of their respective owners.

* Minimum print height and maximum print speed specification compliance can be dependent on non variables such as label type, thickness, spacing, liner construction, etc. Godex is pleased to test non minimum print height and maximum print speed capability.

* Due to ZX1000i+/ZX1000Xi+ Series WiFi module message communication through LAN port, please make sure WiFi module has been removed when you want to use LAN port.

* The cutter is an optional accessory. If the cutter is installed, it is not suitable for children to approach.

APPENDIX — INTERFACE

● Parallel port

Handshaking : DSTB is sent to the printer, BUSY to the host computer

Interface cable : Parallel cable compatible with IBM computers

Pinout : See below

Pin No.	Function	Transmitter
1	/Strobe	Computer / printer
2-9	Data 0-7	Computer
10	/Acknowledge	Printer
11	Busy	Printer
12	/Paper empty	Printer
13	/Select	Printer
14	/Auto-Linefeed	Computer / printer
15	N/C	
16	Signal Gnd	
17	Chassis Gnd	
18	+5V, max 500mA	
19-30	Signal Gnd	Computer
31	/Initialize	Computer / printer
32	/Error	Printer
33	Signal Ground	
34-35	N/C	
36	/Select-in	Computer / printer

● Serial Port

Default settings : Baud rate 9600, no parity, 8 data bits, 1 stop bit, XON/XOFF protocol and RTS/CTS

RS232 Housing(9-pin to 9-pin)		
DB9 Socket		DB9 Plug
-	1_____1	+5V, max 500mA
RXD	2_____2	TXD
TXD	3_____3	RXD
DTR	4_____4	N/C
GND	5_____5	GND
DSR	6_____6	RTS
RTS	7_____7	CTS
CTS	8_____8	RTS
RI	9_____9	N/C
Computer		Printer

Notice

* The total current to the serial port may not exceed 500mA.

● USB Port

Computer Connector : Type A				
Pin No.	1	2	3	4
Function	VBUS	D-	D+	GND

Computer Connector : Type B				
Pin No.	1	2	3	4
Function	VBUS	D-	D+	GND

● Ethernet (RJ-45)

Pin No.	Fuction
1	T+
2	T-
3	R+
4	N/C
5	N/C
6	R-
7	N/C
8	N/C

● Applicator

PIN NO.	FUNCTION
1	GND
2	+5V,max 500mA
3	START_PNT
4	SLEW_LABEL
5	PAUSE
6	REPRINT
7	+24V,max 1.5A
8	GND
9	RIBBON_LOW
10	SERV_REQ
11	END_PRINT
12	MEDIA_OUT
13	RIBBON_OUT
14	DATA_READY
15	OPT_FAULT

APPENDIX — Parallel module or Applicator module installation diagram

Step 1.

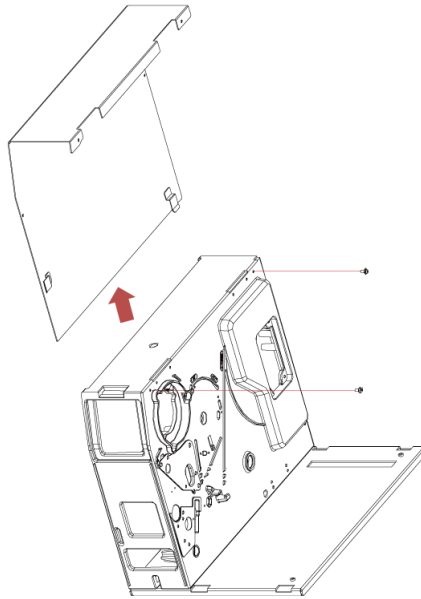

Step 2.

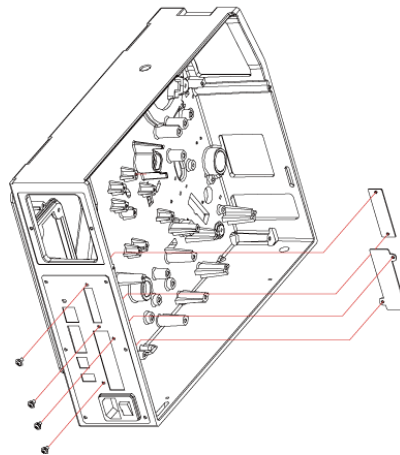

Step 3.

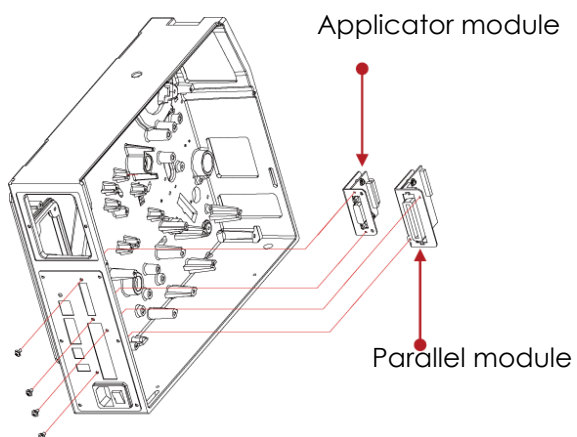

Enable LPT Port Function

Connecting the printer to the computer, follow the instructions below to enable the LPT function.

Step 1. Download GoTool and open Goconfig

Step 2. Click "Printer I/O Setup" then click "Port Active"

(Please go to the Godex official website to download.)

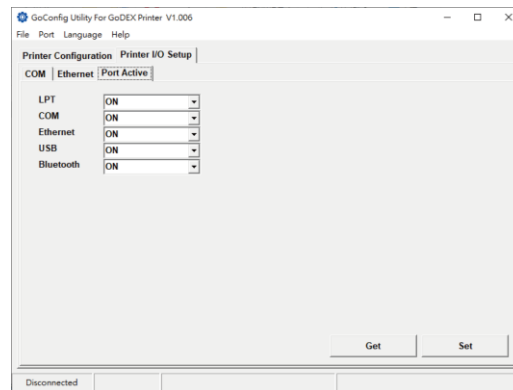
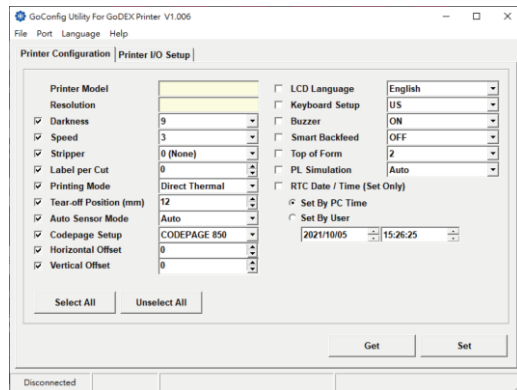

Step 3. Click "Printer I/O Setup" then click "Port Active"

Step 4. Choose "ON"

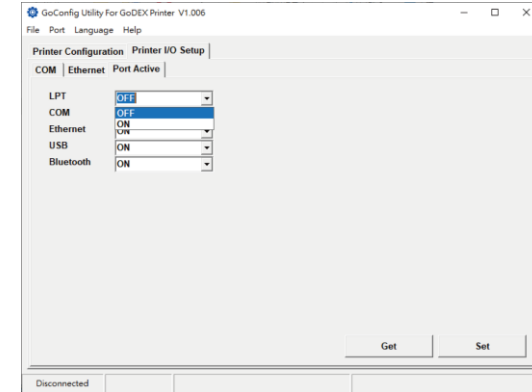
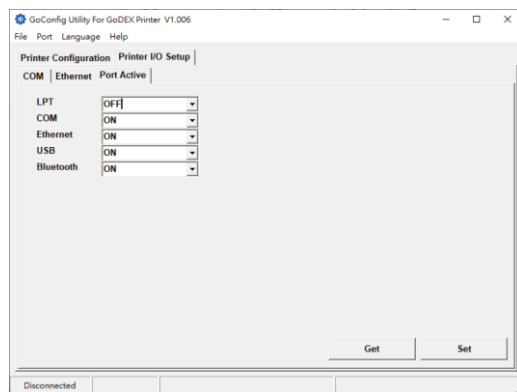

Step 5. Press Set to complete setting

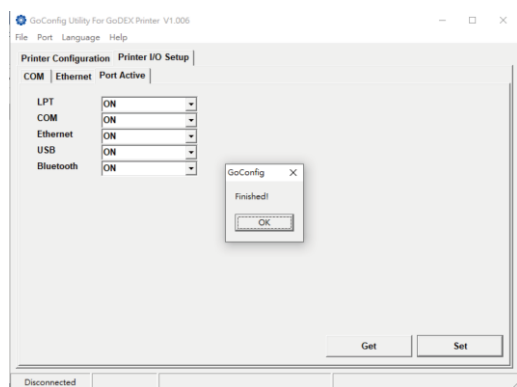

APPENDIX — Label Dispenser & Liner Rewind Module Installation

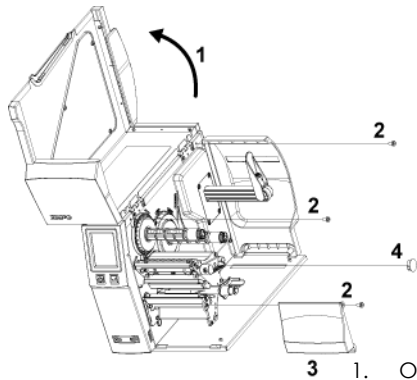

1. Open the right side cover
2. Remove leftmost and rightmost screws
3. Remove the front cover
4. Remove the plug

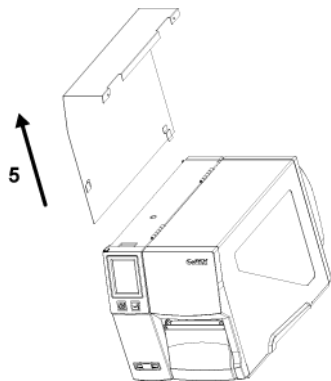

5. Remove the left side cover

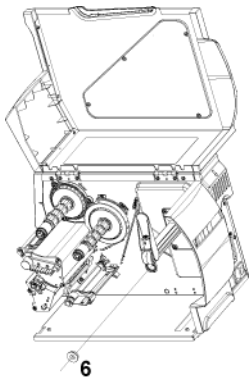

6. Insert bearing

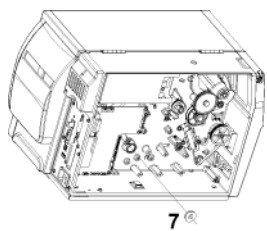

7. Insert bearing

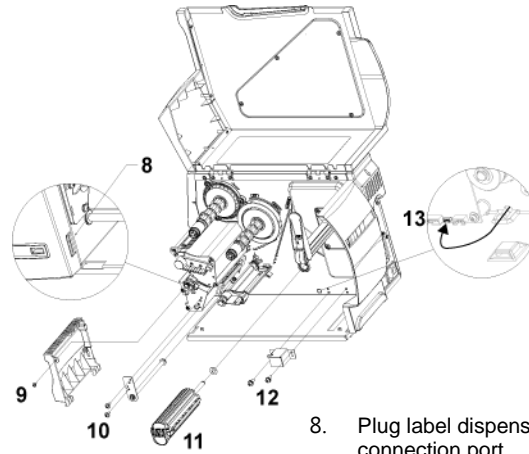

8. Plug label dispenser connector into the connection port
9. Install label dispenser cover and screw
10. Install roller combination
11. Install backing paper recycling roller combination
12. Install Label Full sensor
13. Plug sensor connector into connection port

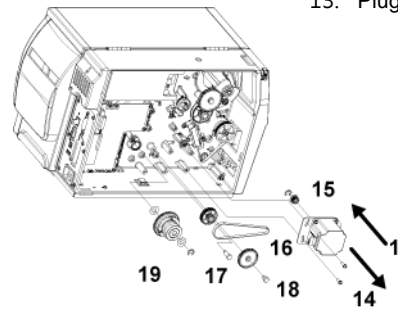

14. Remove the motor combination
15. Install 22t gear and retaining ring
16. Install motor combination and pull the belt
17. Install gear combination (Gear column add silicone oil)
18. Install gear combination (Gear column and gear add silicone oil)
19. Install clutch combination

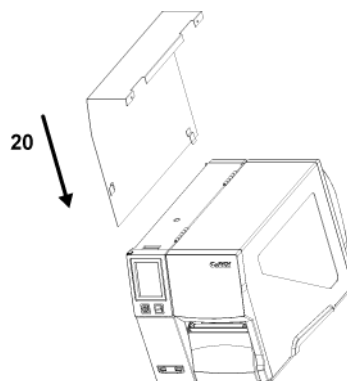

20. Install left side cover

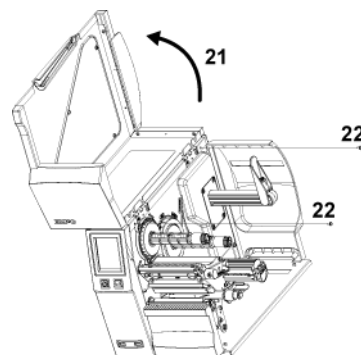

21. Open the right side cover
22. Reattach leftmost and rightmost screws

APPENDIX — BT & WiFi Module Installation

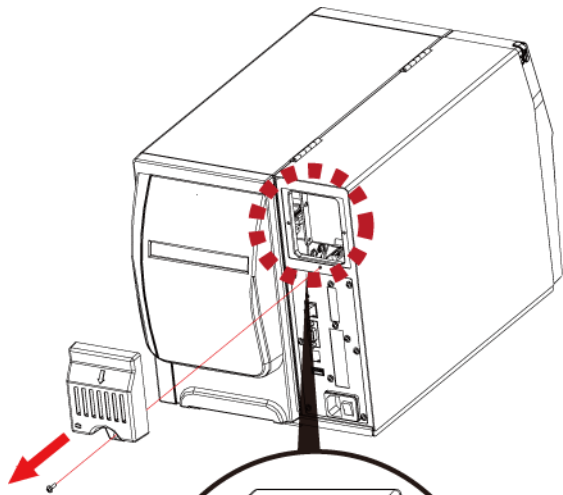

1. Remove the screws
2. Unattach the option cover

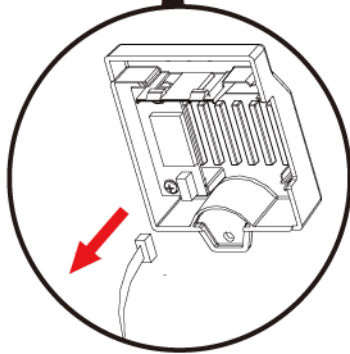

3. Unattach the connector

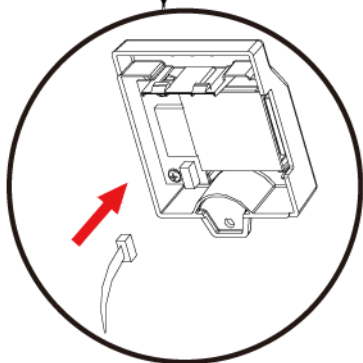

4. Insert BT Module
5. Plug the connector

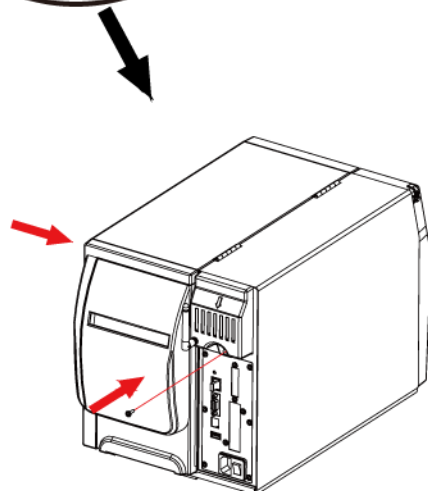

6. Put the option cover back and screw it

APPENDIX — Wi-Fi setting

Steps for setting Wi-Fi module

Step 1. Power off the printer.

Step 2. Install the Wi-Fi module.

Note : Methods for installing Wi-Fi module, please refer to Wi-Fi module installation.

Step 3. Power on the printer and wait 15 seconds. The main manu will display gray Wi-Fi icon and it means that the Wi-Fi module is already detected by the printer, as the figure below indicates.

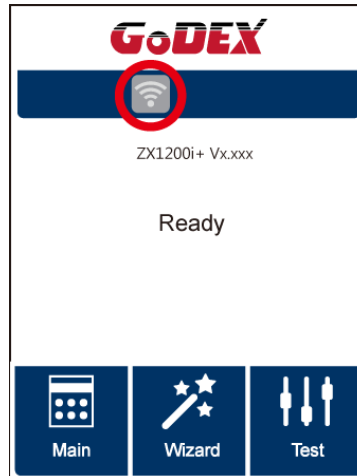

Note

* The firmware version of the printer should be above V.2005, otherwise you can not use Wi-Fi function.

** GoLabel version should be above V1.12, otherwise you can not use Wi-Fi Tool function.

*** When a Wi-Fi module is installed into a printer, the Ethernet of the printer will lose its function.

Steps for setting Access Point (D-Link)

Step 1. Execute browser and log in the setting page of access point.

Step 2. Click "WIRELESS SETUP" on the left side of the setting page (red circle 1) and enter into AP setting page.

For the contents of setting, please refer to the figure below.

Step 3. Click "Save Settings" button after the Wi-Fi AP is completely set.

After approx.20 Seconds, the the setting of AP is stored and takes effect.

The screenshot shows the configuration interface for a D-Link DAP-1360 access point. The page is divided into several sections: WIRELESS NETWORK, WIRELESS SECURITY MODE, WPA, and PRE-SHARED KEY. Red annotations highlight key elements:

- 1:** Points to the "WIRELESS SETUP" menu item in the left sidebar.
- 2:** Points to the "Wireless Network Name" field, which contains "MXAP". A label "Wireless Network Name" points to this field.
- 3:** Points to the "Security Mode" dropdown menu, which is set to "WPA-Personal". A label "Security Mode" points to this dropdown.
- 4:** Points to the "Pre-Shared Key" field, which contains "8LCKNM6B0CFB7JIDGDA7J53QMB". A label "Code" points to this field.
- 5:** Points to the "Save Settings" button at the top of the configuration area. A label "Save Settings" points to this button.

Additional labels include "Save Settings" pointing to the button in the top left and "Wireless Network Name" pointing to the field in the top right.

Methods for setting Wi-Fi module

How to execute Wi-Fi Tool

Step 1. Execute GoLabel II

Step 2. Select desired ZX1200+ printer model, as the figure below indicates.

Step 3. Click "Save", as the figure below indicates.

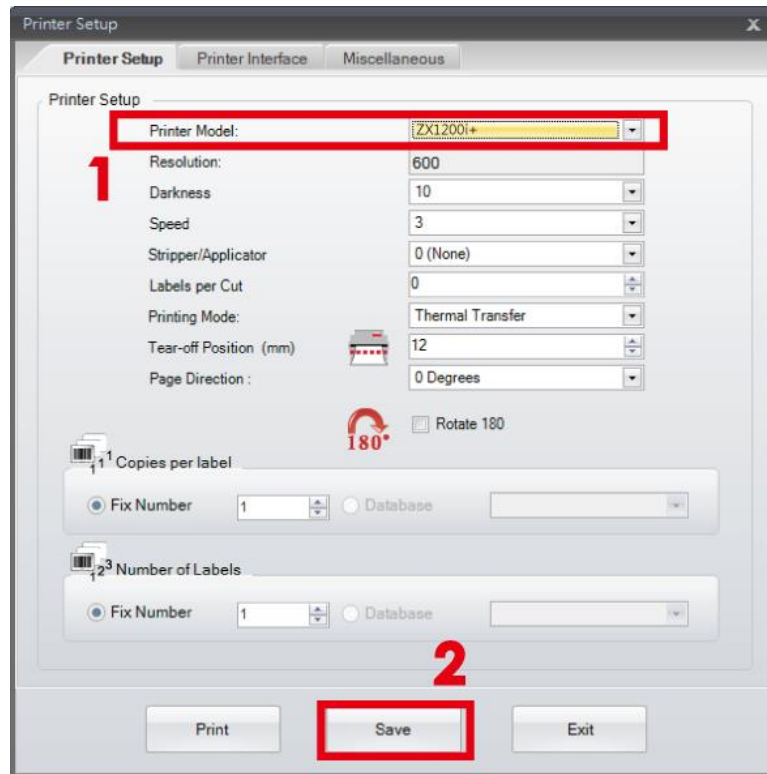

Step 4. Execute Wi-Fi Tool, as the figure below indicates.



How to set the corresponding items between Wi-Fi Tool and AP

Step 1. Set Wi-Fi parameters, as the figure below indicates.

Step 2. Click "Set Data" button after the parameters are completely set.

Approx. 5 seconds later, the printer will automatically reboot.

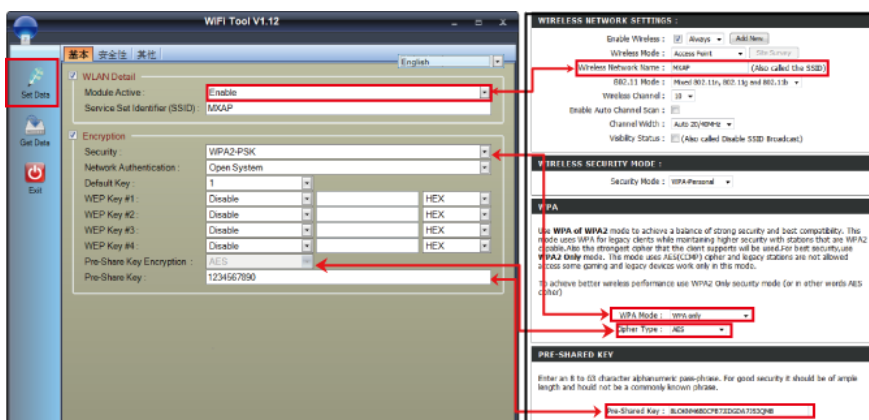

Step 3. Approx. 15 seconds, LCD panel will display gray Wi-Fi icon, and it means that the Wi-Fi module is already detected by the printer.

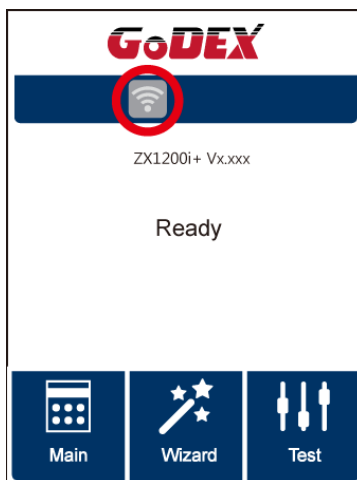

Note

* The Setting content of Wi-Fi Tool should be corresponding with the setting of AP.

Check whether the Wi-Fi connection is successfully created

After 8~10 seconds, the Wi-Fi icon's will change from gray to purple

and it means that the Wi-Fi connection is successfully created, as the figures below indicate.

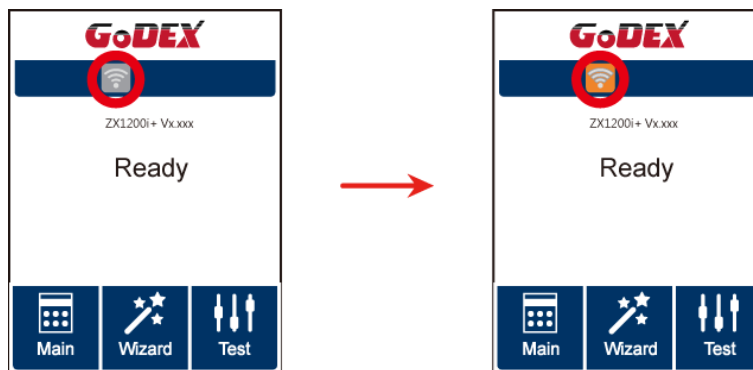

Check the related information of LAN

Step 1. Select "Main" on the bottom left Corner of LCD panel.

Step 2. Select "Devices"

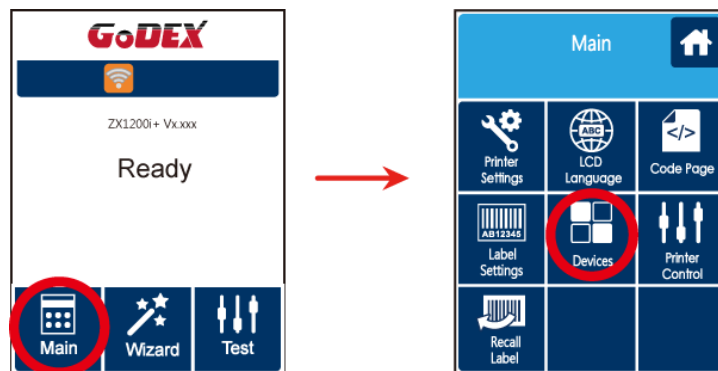

Step 3. Select "LAN Settings" and the display indicates the related information of LAN

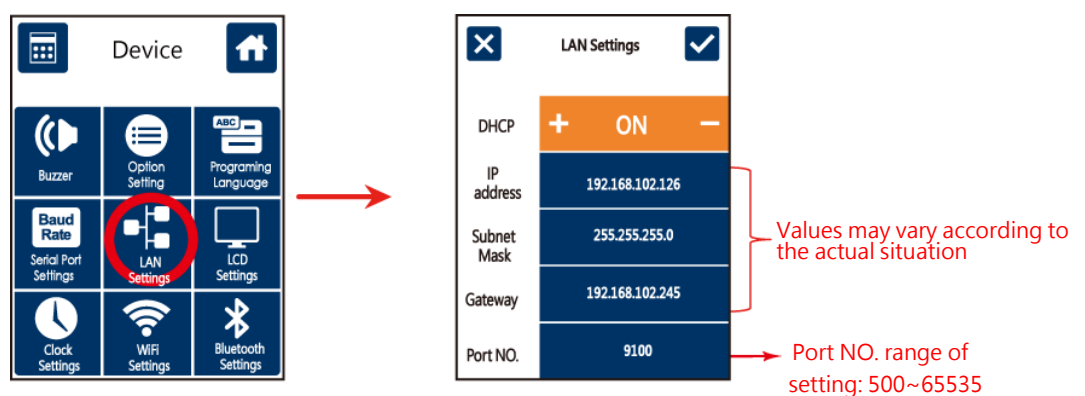

How to create a connection between computer and printer via Wi-Fi

Step 1. Execute GoLabel II

Step 2. Select "Printer Setup"

Step 3. Select "Printer Interface" and Click "LAN Port ",and enter IP address, as the figure below indicates.

Step 4. Click"Save"

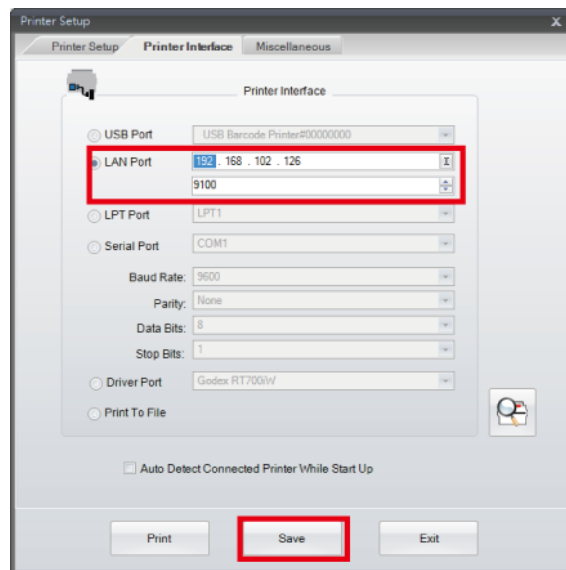

Step 5. Select "Virtual Terminal" and enter "~B" into "Command field", and then click"Send".

The Wi-Fi connection is working if the printer return related information automatically, as the figure below indicates.

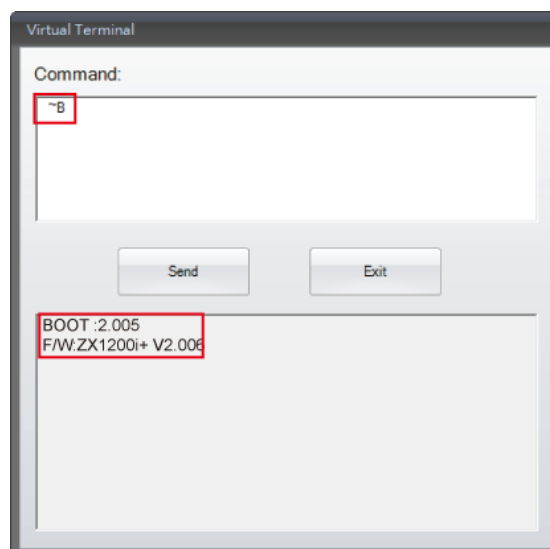

APPENDIX — Wi-Fi Printer Sever Module Installation(Quick Setting)

* Quick setting only supports GoLabel 1.15K and Arm 7 (FW1.100)

Or Arm 9 (FW2.00A) or higher version

Set up wireless network through GoDEX WiFi tool

1. Turn on the printer, connect printer and computer by USB cable.
2. Start GoLabel II.
3. "Generic" → "Printer Setup".

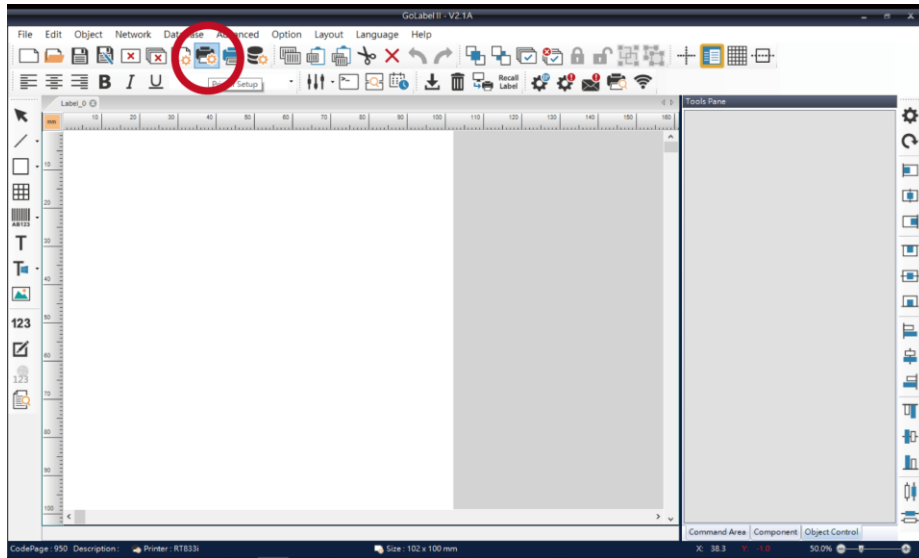

4. Select printer model(Wi-Fi supported models).

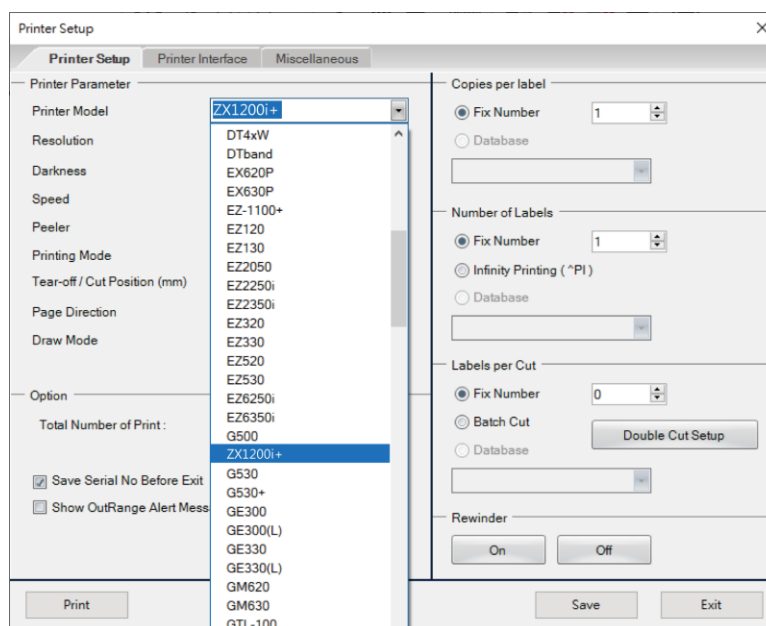

5. Click "WiFi Setting" icon.

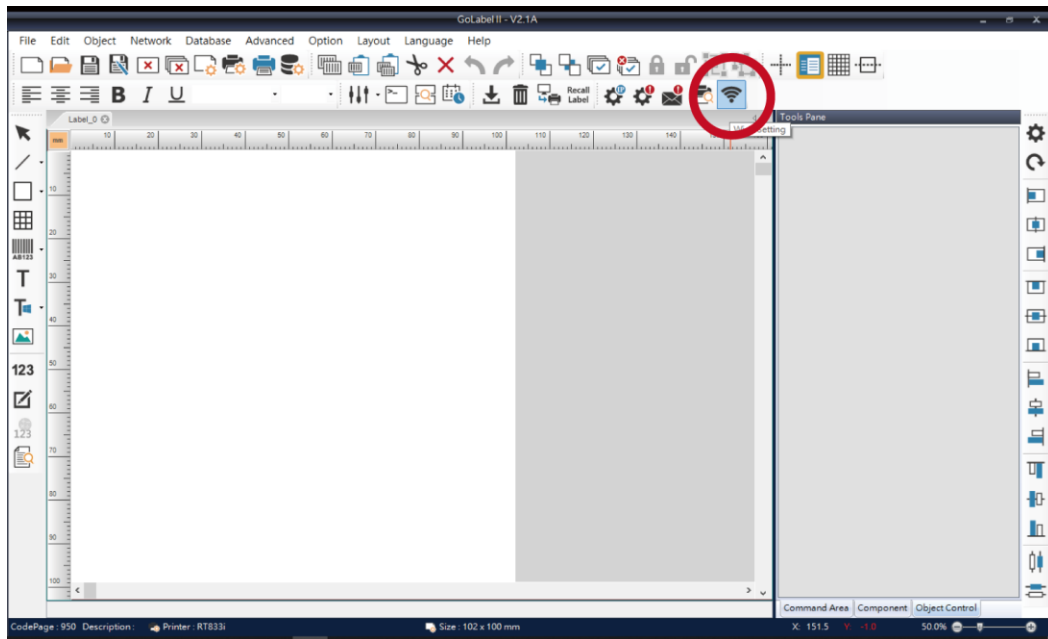

6. Click "Quick Setting" icon.

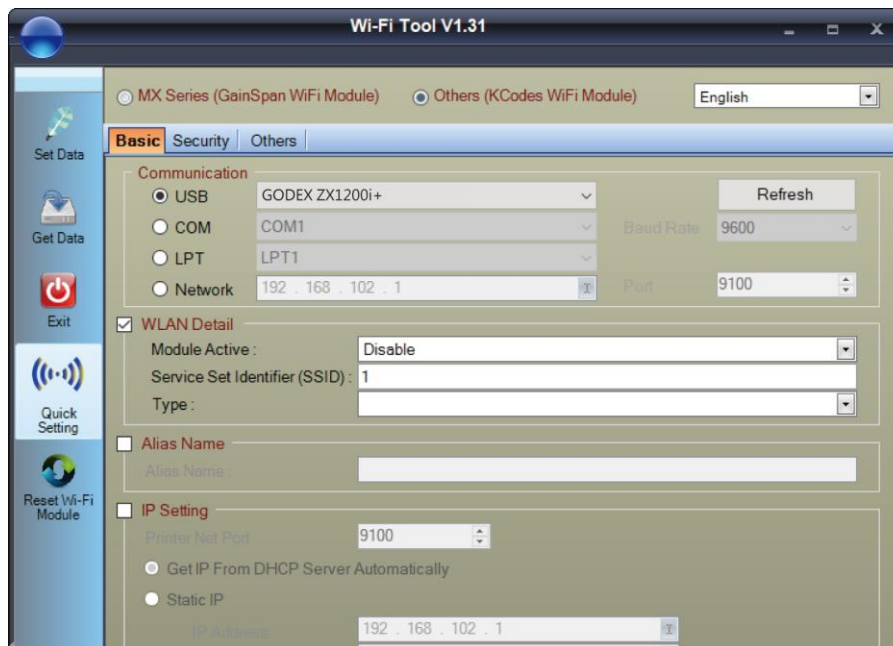

7. Click the Search button.

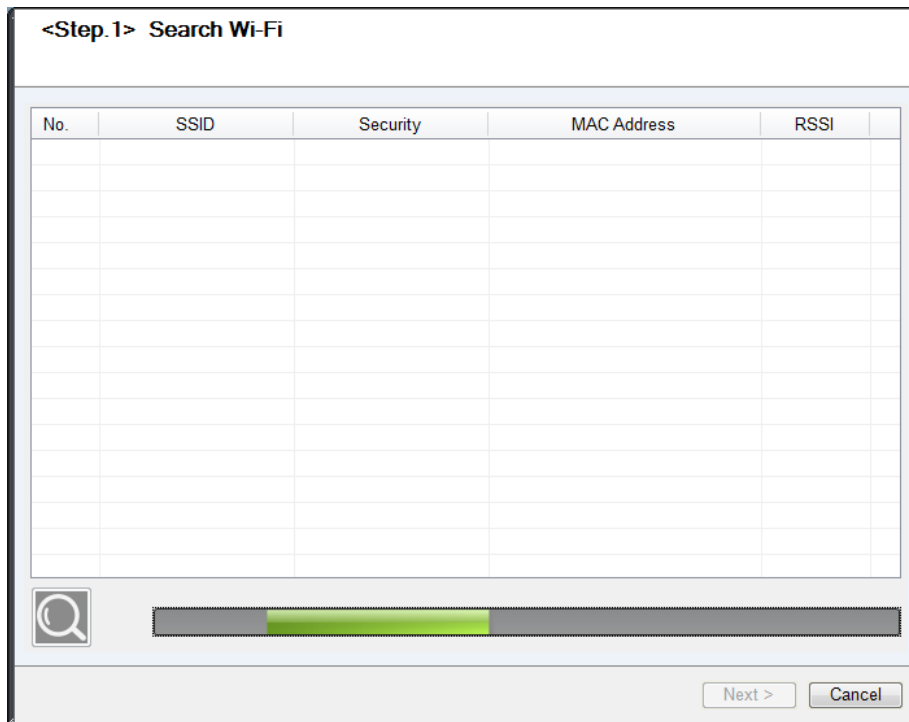
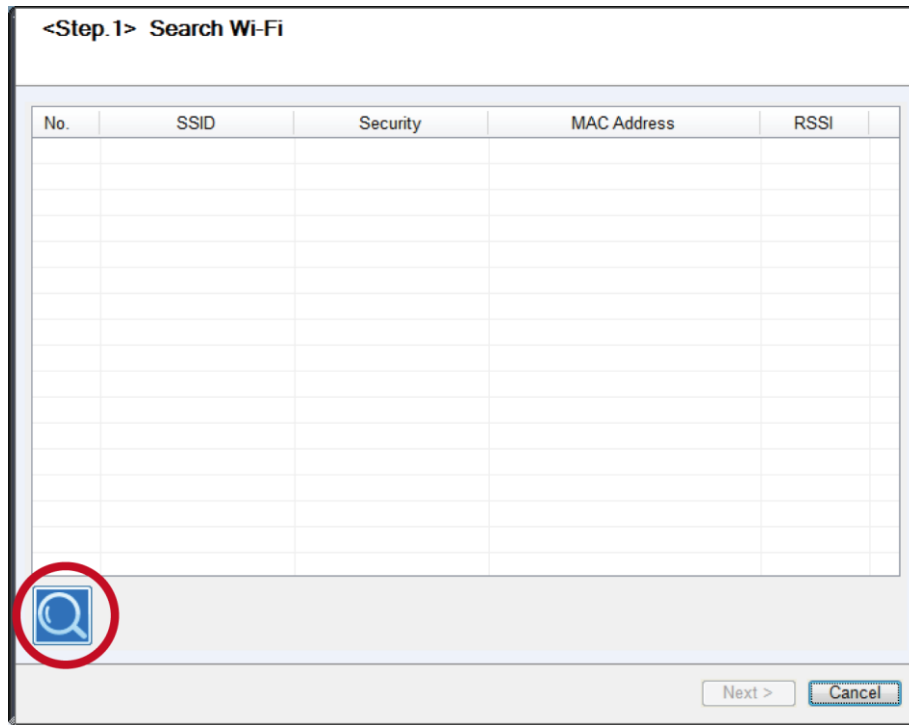

8. Select server and click **next** button.

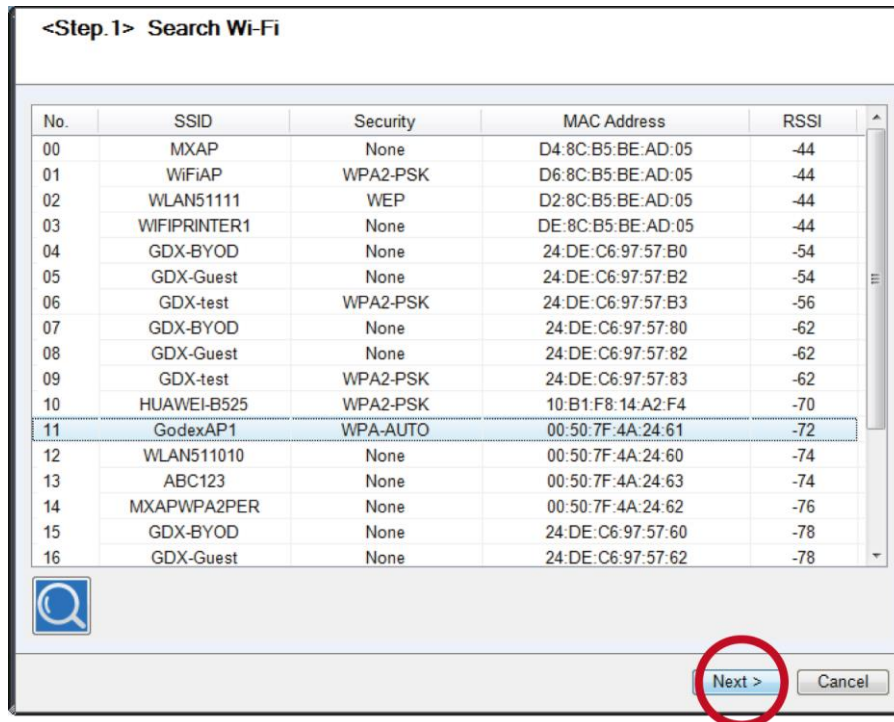

9. Enter the **password** set on the server side and click the "Setting" button.

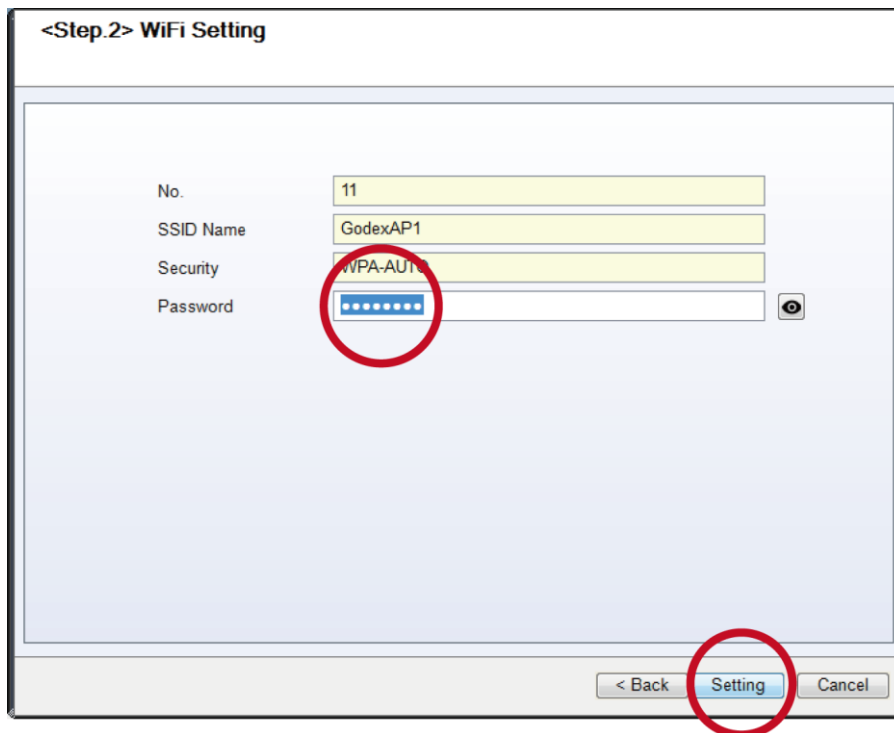

10. After the setting succeeded, a prompt will pop up and the printer will restart.

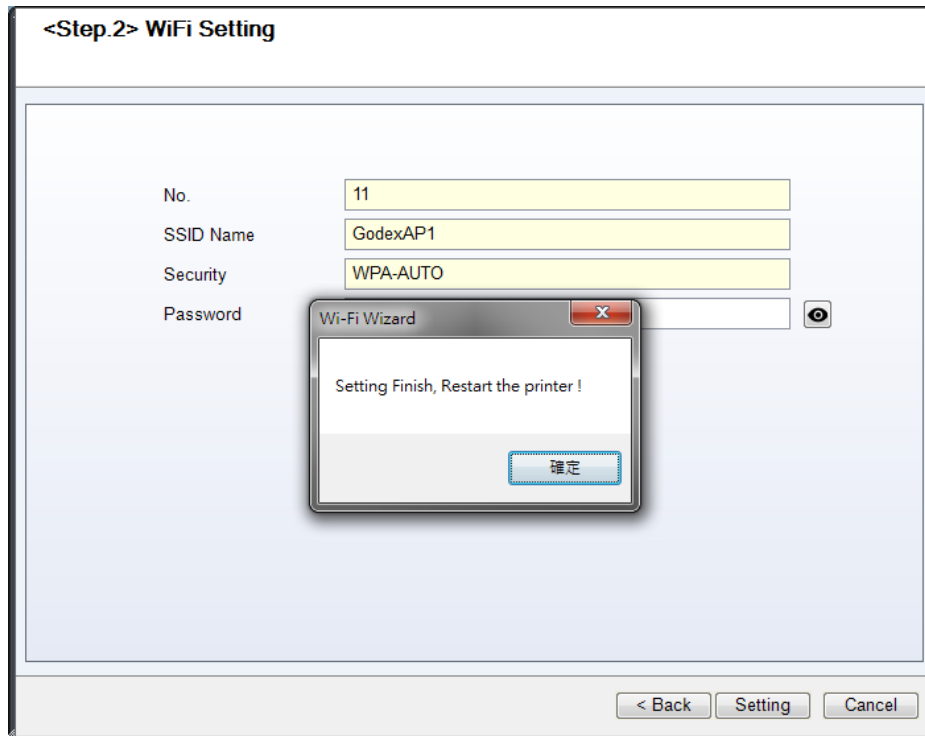

11. Select the "Other" tab and click the "Get Data" icon after selecting "IP Settings".

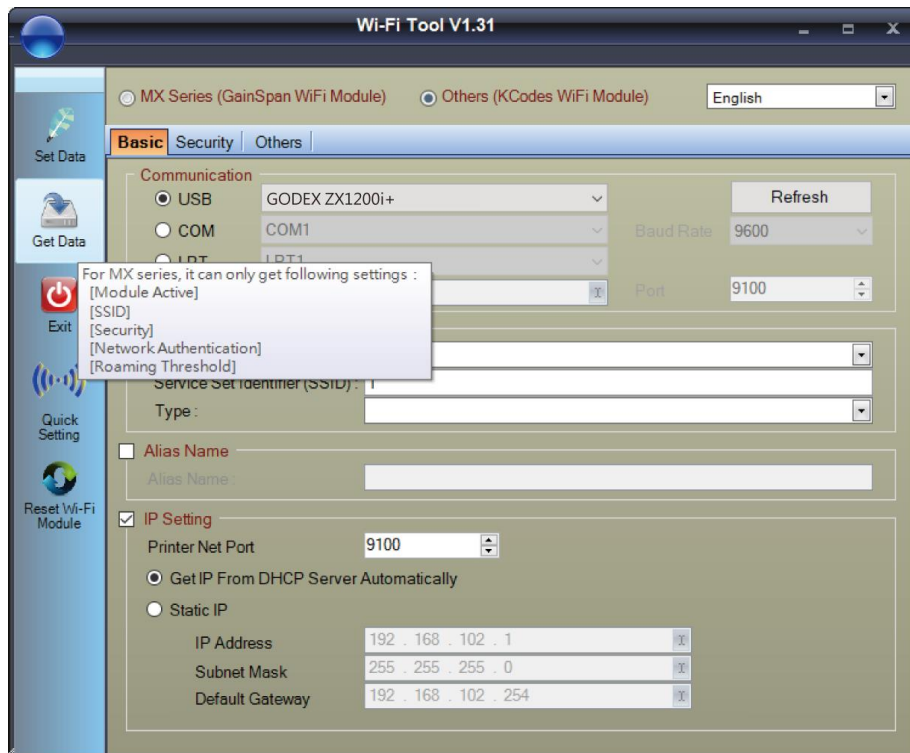

- After remembering the IP address, open the "Printer Settings" window.

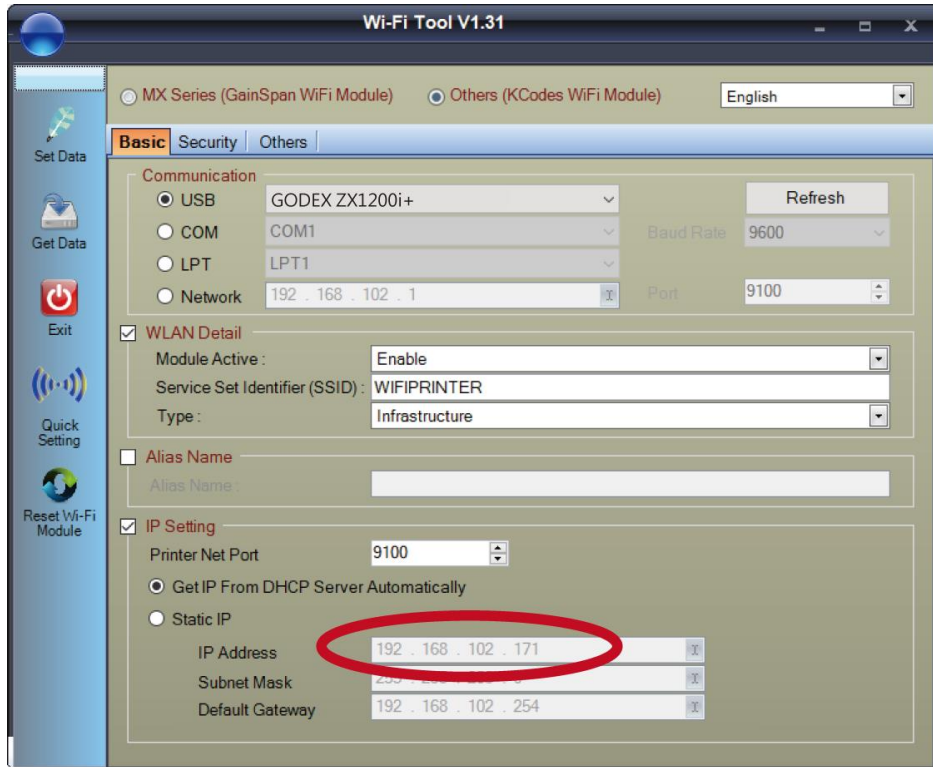

- Select the "Printer Interface" tab, fill in the IP address and click "Save" to complete the setting.

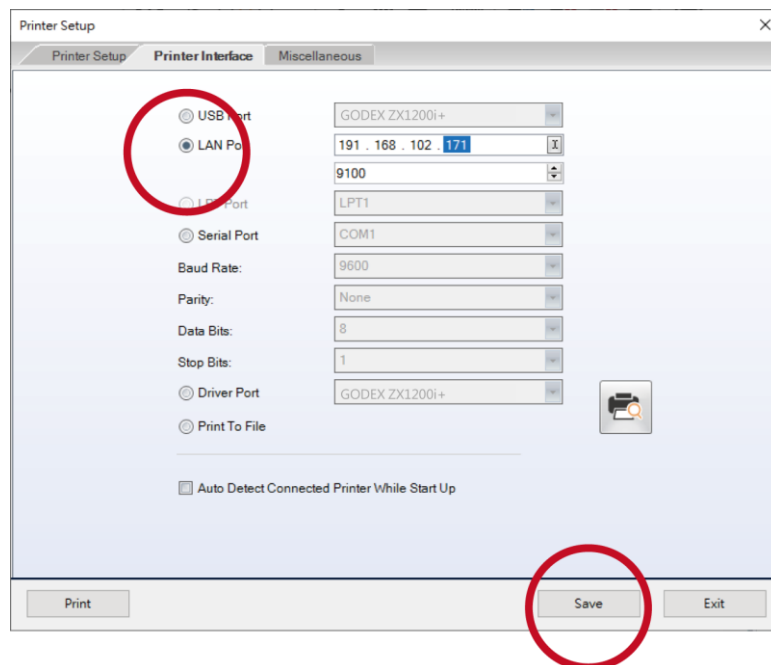

APPENDIX — Liner Rewind Operation

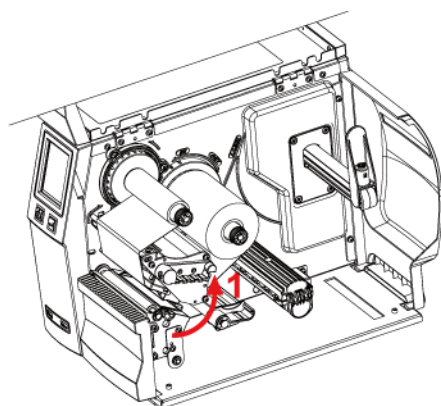

1. Open TPH rotary arm

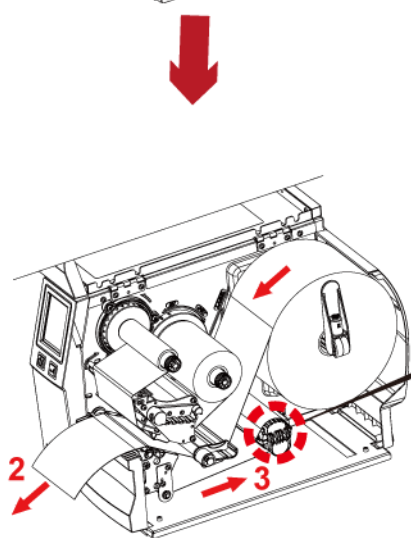

2. Install the label roll

Check whether the rewinder knob is in closed position

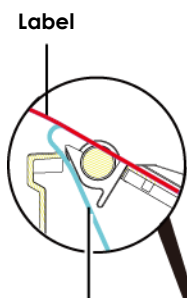

Liner

3. Pull the Liner back to rewinder shaft and rotate it in 2~3 circles

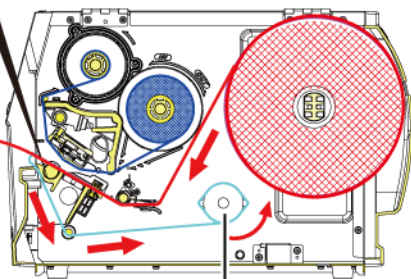

Rewind shaft

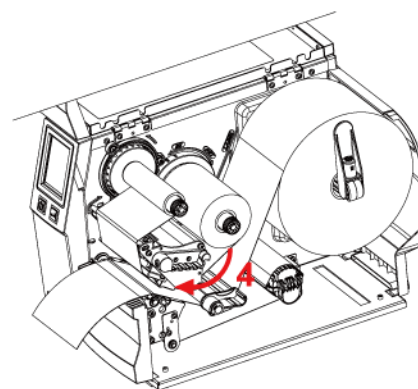

4. Close TPH rotary arm and the printer is ready to print

Note

* With the rewind installed, set the stop position in GoLabel (E value) and Driver to 6.

* Liner rewind can be operated without setting GoLabel and Driver .

Remove Liner Roll

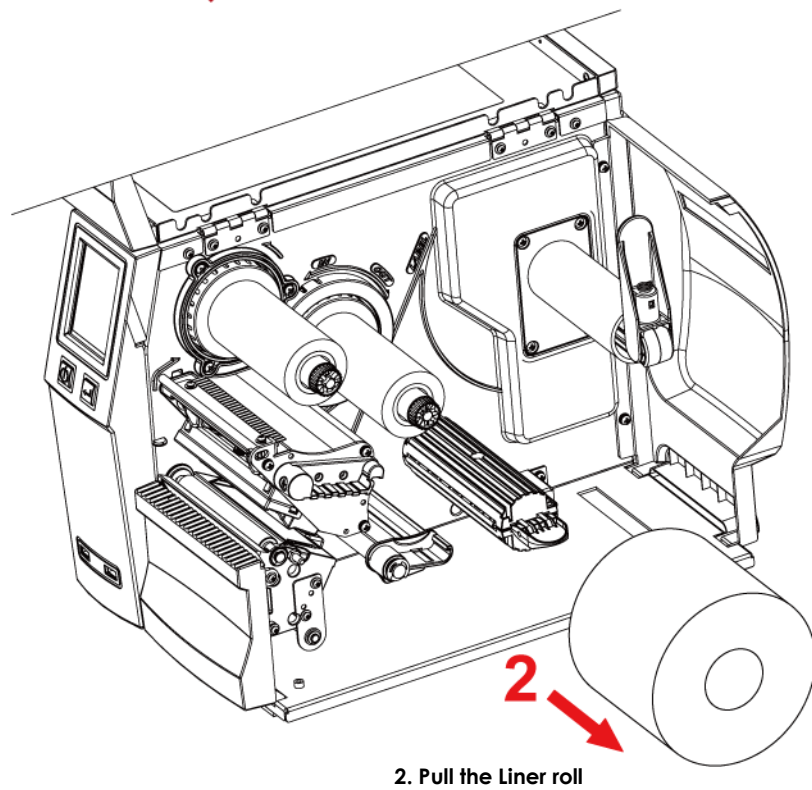
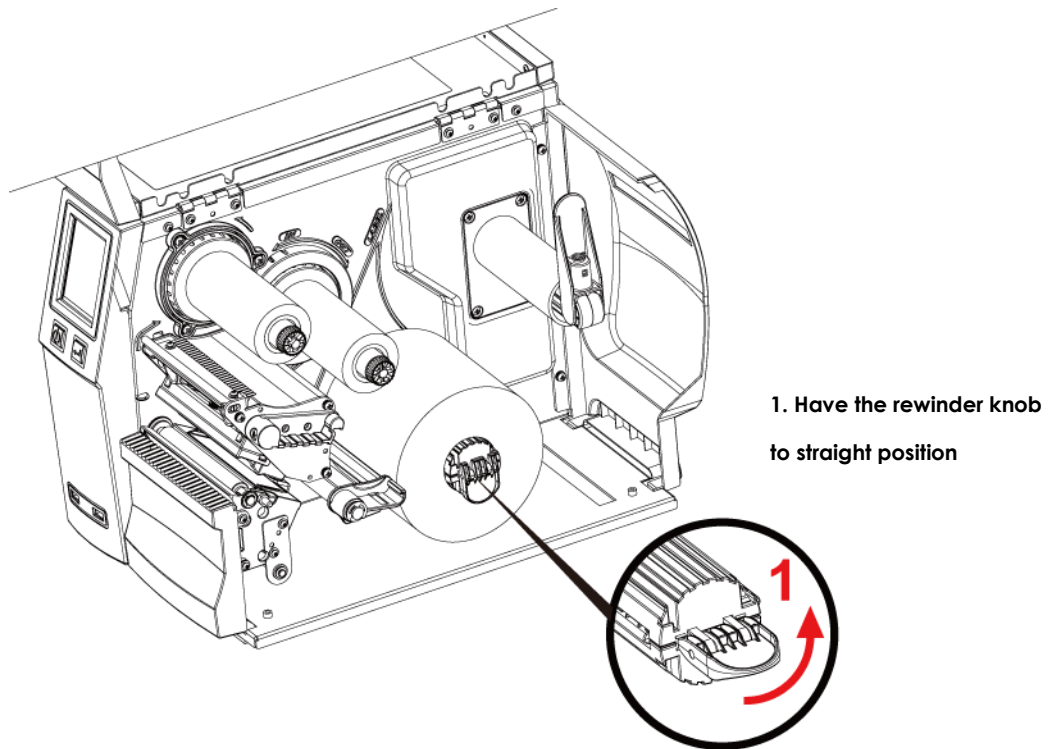

Note

* The rewind is applied to liner only, and do not use it with other printed labels.

* If any adhesion is left on the label dispenser cover, Please clean it with soft fabric and denatured alcohol.

APPENDIX — Installation Guide for Perforation Cutter

Overview Of Perforation

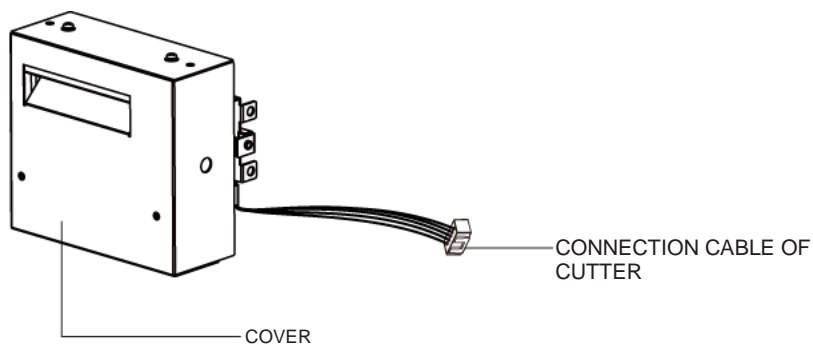

Caution

- * Power off the printer and remove the cable from the connector before perforation cutter module installation
- * Labels with adhesive glue are not applicable or otherwise could result to malfunction
- * Applicable label size is at maximum width of 80mm and minimum length of 30mm.
(Usage with labels outside this range will be excluded from warranty terms)
- * Stop position (E value) should set to 51 through GoLabel before using the perforation cutter
- * After the cutter is installed, please send the command `^XSETCUT,MODE,0,2` through Golabel to activate the cutter.
- * After the perforation cutter is installed, please send the command `^D1,5` through Golabel to specify the cutter type(perforation cutter).
- * Command : `^XSETCUT,MODE,0,2`→Full Cut · `^XSETCUT,MODE,1,2`→Perforation Cut

This cutter module is suitable for Firmware V2.100 or later.

Preparation Steps

For more details about the preparation steps to install optional modules, please refer to printer User Manual.

(Power off the printer and remove the power cable before installing the perforation cutter module)

1. Loose the screw (as circle indicated).

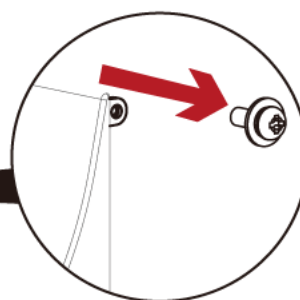
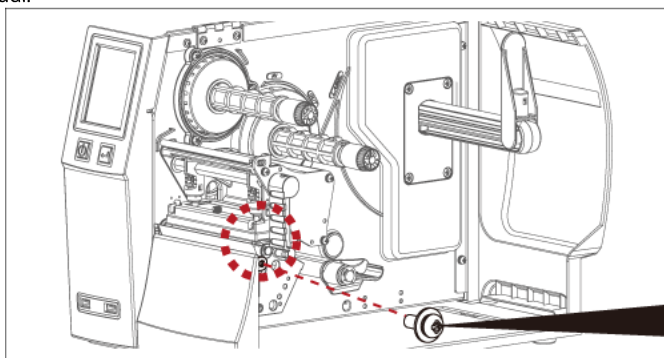

2. Remove the cover panel by pushing to the direction of right-hand side.

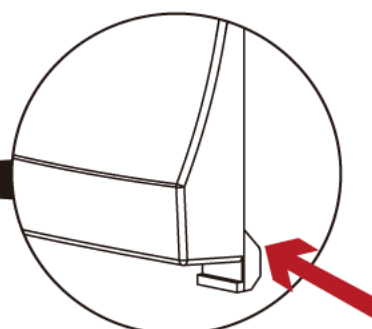
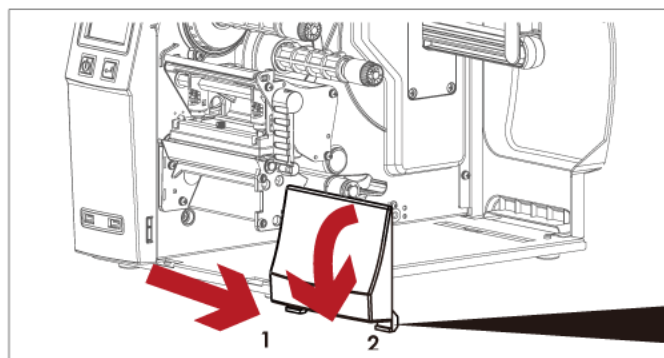

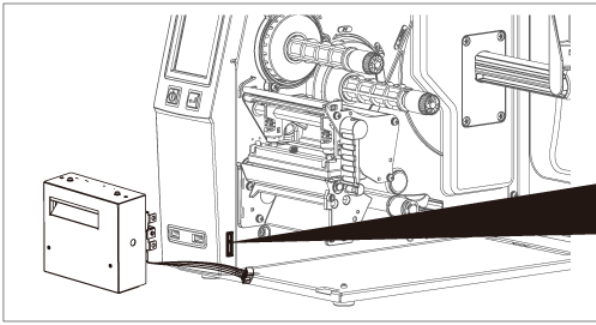

3. Plug in the cable connector to the bottom 5-PIN jack of printer's left panel

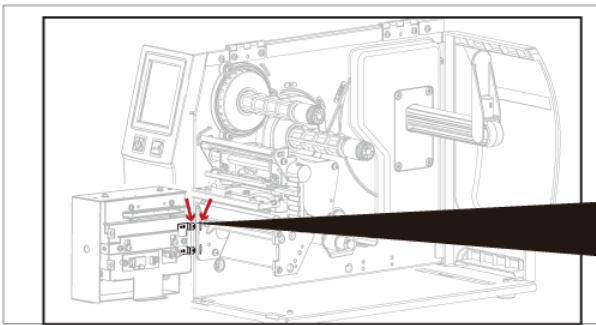

4. Insert the perforation cutter module to dock with the printer

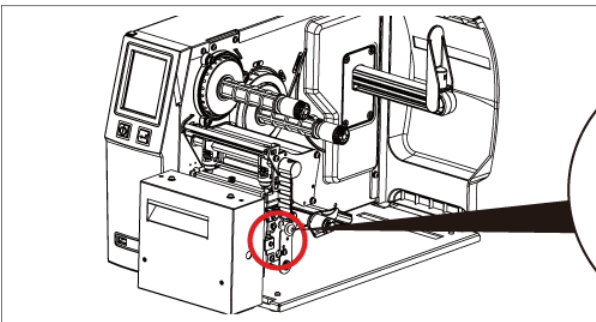

5. Hold the perforation cutter module firmly and tighten the screw

6. Installation is now complete

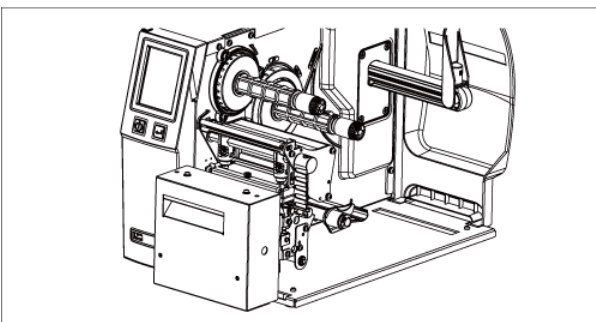

7. Load consumables and close printer cover

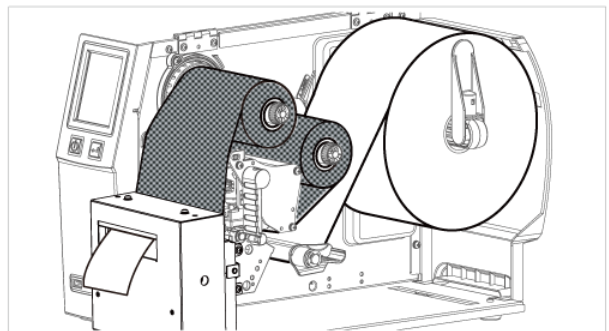

Caution

* Printer power should be off when plugging the connector to avoid malfunction

Cleaning Method

1. Remove the screws and cover.

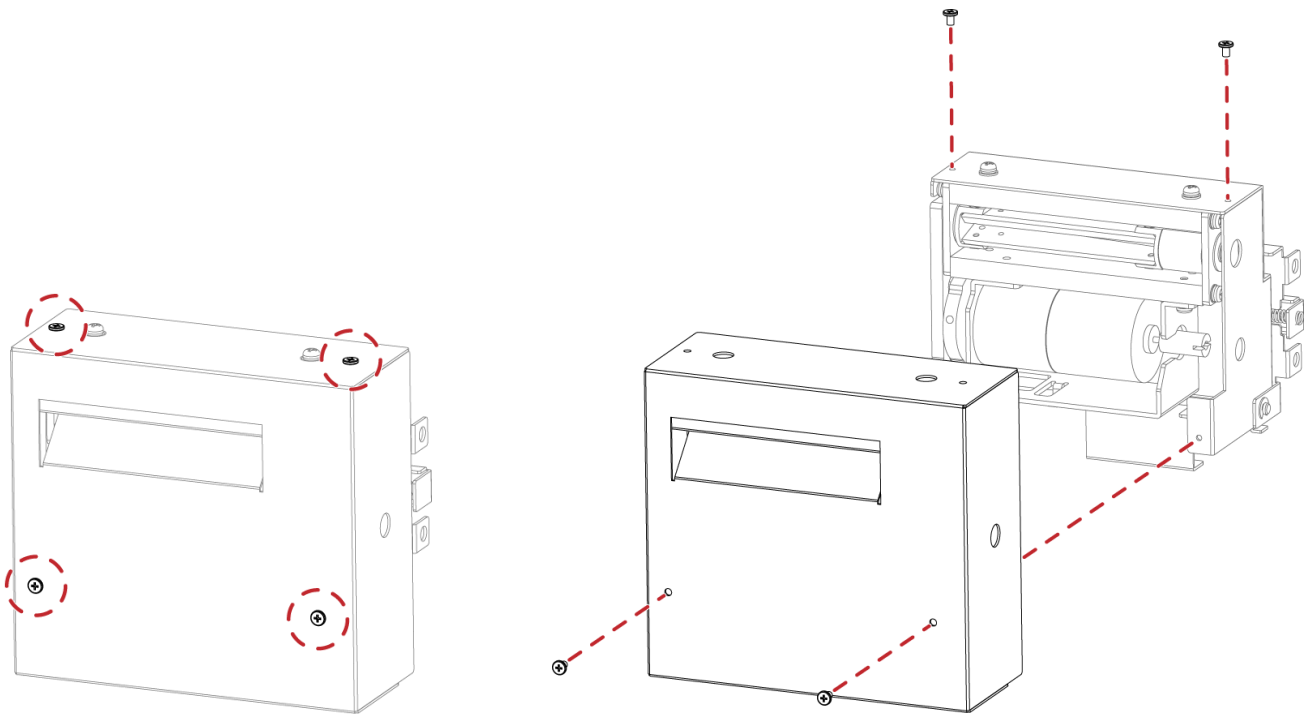

2. Wipe with a cotton swab or dry lint-free cloth (turn the gear to adjust the angle of the cutter)

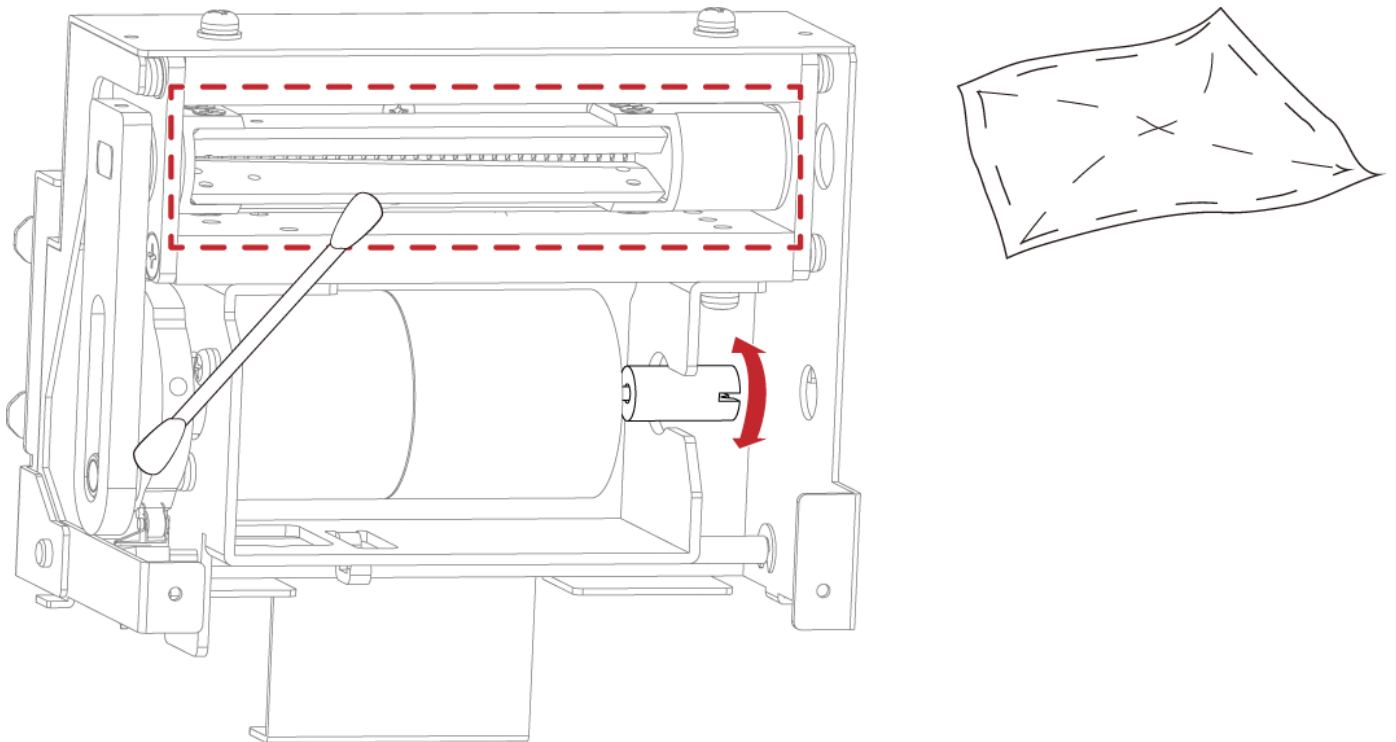

APPENDIX — Installation Guide for Paper Card Cutter

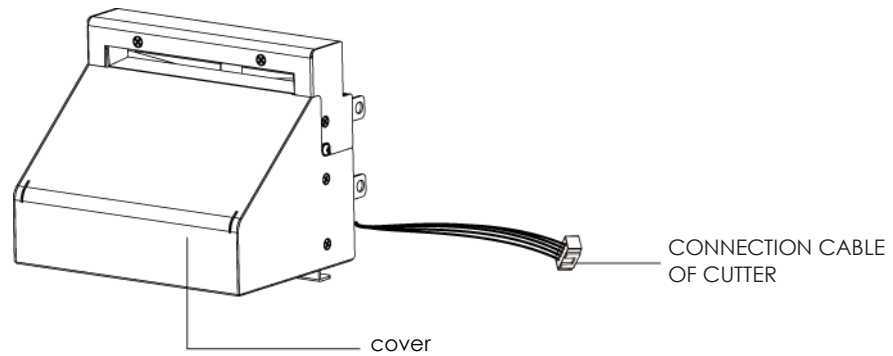

Caution

- * Power off the printer and remove the cable from the connector before cutter module installation
- ** Labels with adhesive glue or inner roll are not applicable or otherwise could result to malfunction
- *** Applicable label size is at maximum width of 118mm and minimum length of 30mm.
(Usage with labels outside this range will be excluded from warranty terms)
- **** Stop position (E value) should set to 32 through GoLabel before using the cutter
- ***** After the cutter is installed, please send the command ^D1,5 through Golabel to set the cutter.

This cutter module is suitable for Firmware V2.100 or later.

Preparation Steps

For more details about the preparation steps to install optional modules, please refer to printer User Manual.

Installation Steps: (Power off the printer and remove the power cable before installing the cutter module)

1. Loosen the screw (as circle indicated).

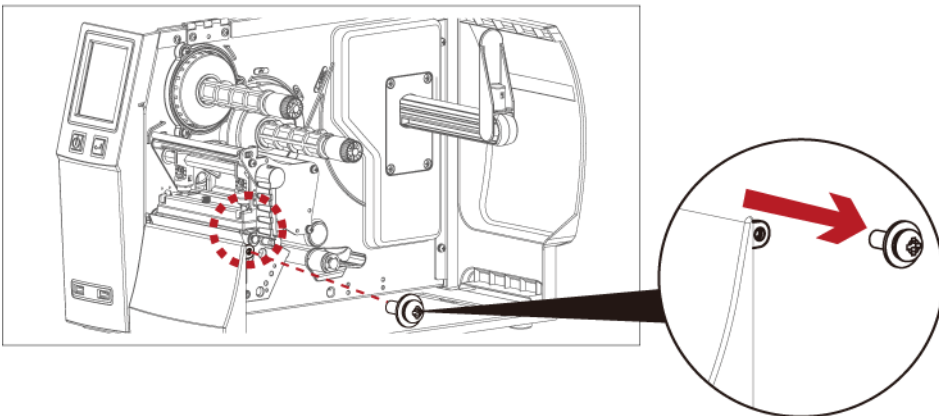

2. Remove the cover panel by pushing to the direction of right-hand side.

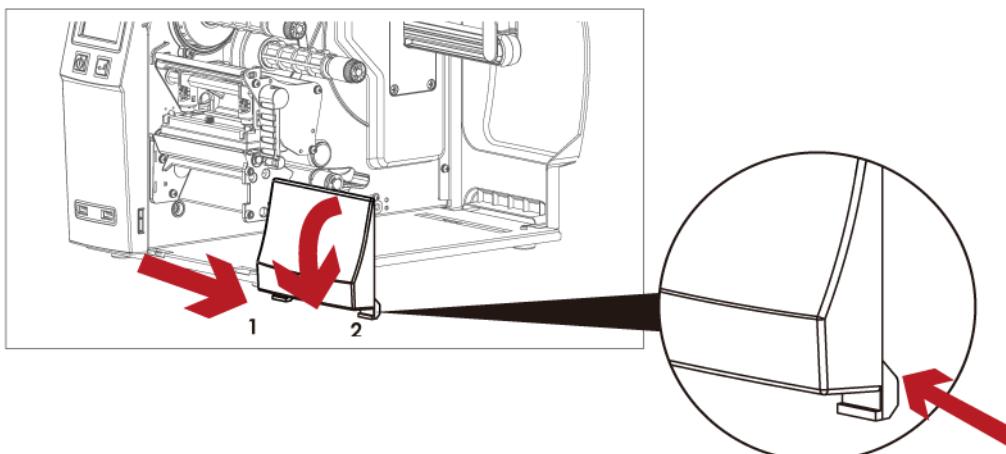

3. Plug in the cable connector to the bottom 5-PIN jack of printer's left panel

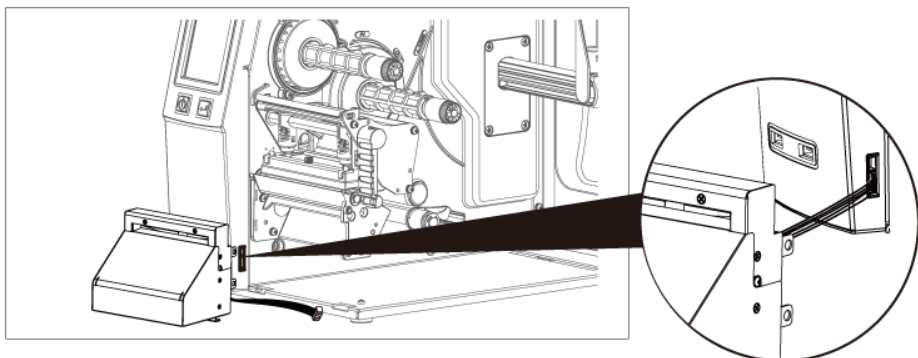

4. Insert the cutter module to dock with the printer

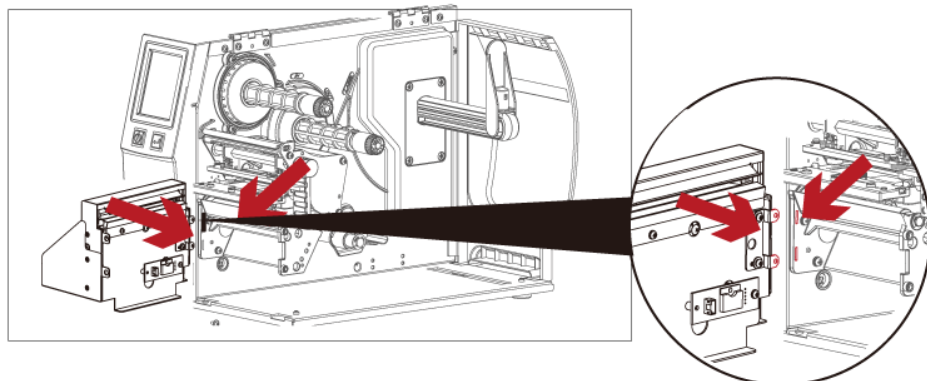

5. Hold the cutter module firmly and tighten the screw

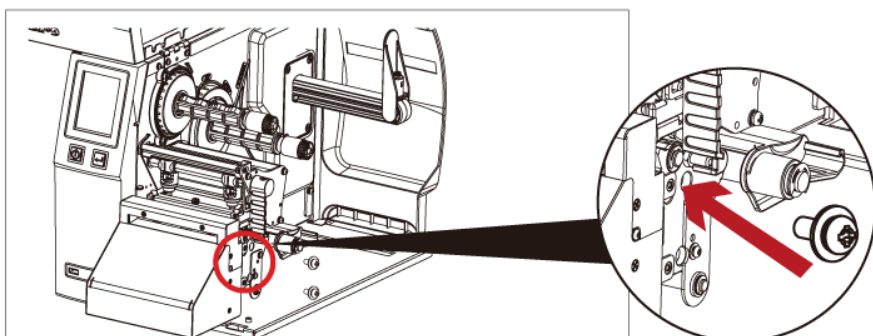

6. Installation is now

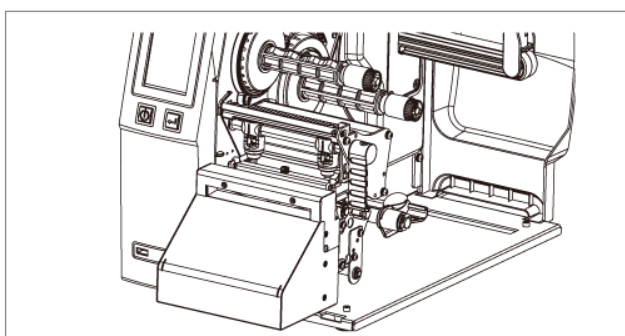

7. Load consumables and close printer cover

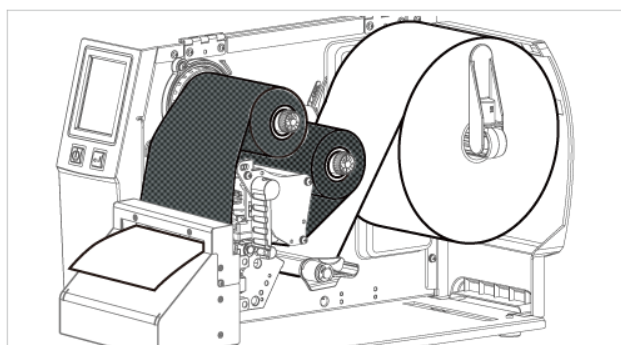

Caution

* Printer power should be off when plugging the connector to avoid malfunction

Cleaning Method

1. Remove the screws and cover.

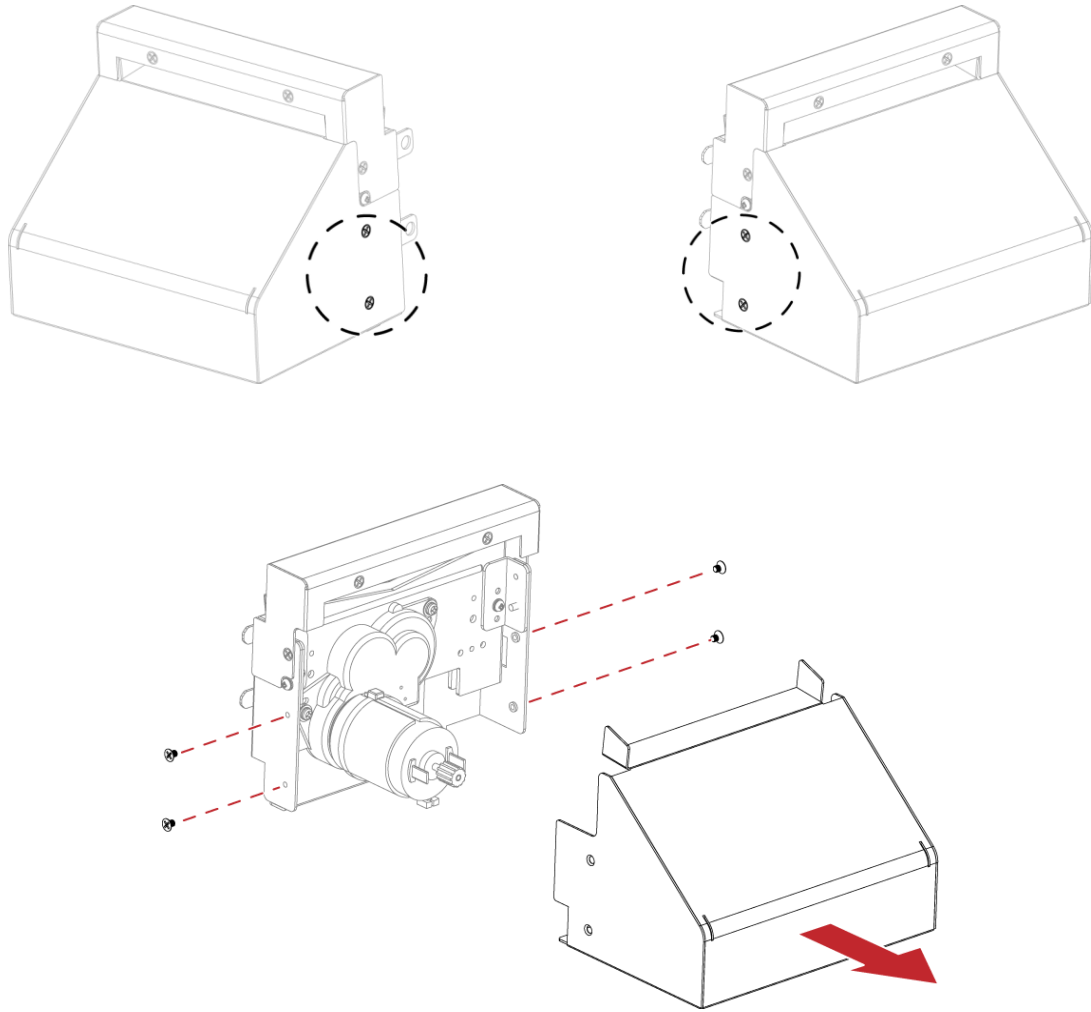

2. Wipe with a cotton swab or dry lint-free cloth (turn the gear to adjust the angle of the cutter)

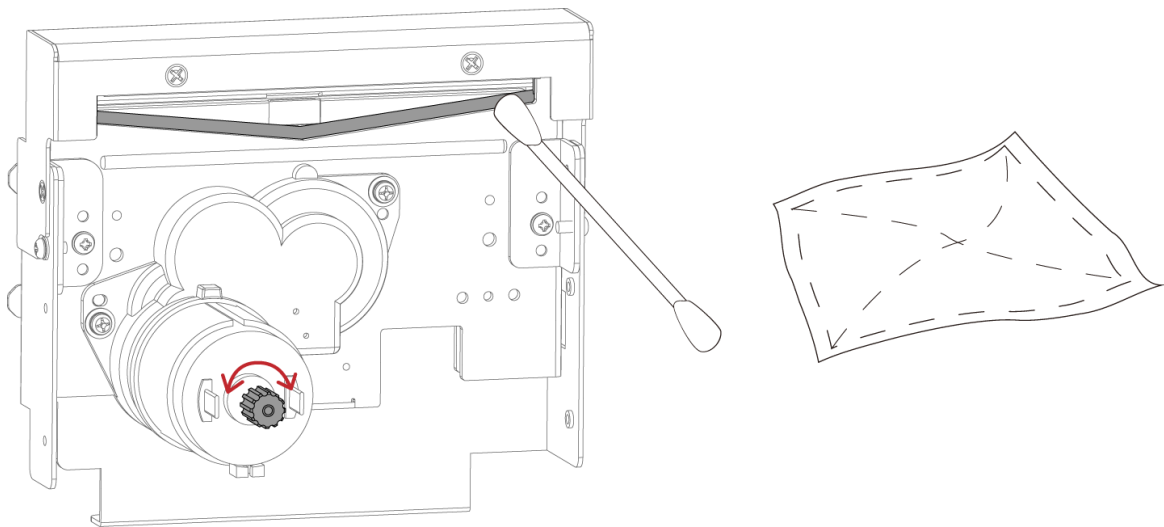

APPENDIX — High-Speed Cutter (MK147) Installation Guide

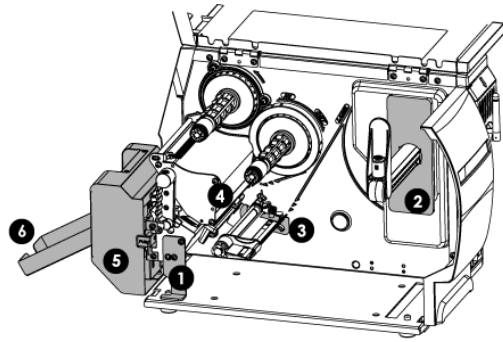

1



Platen module bracket

2

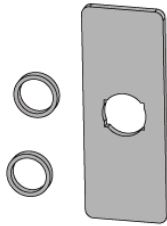

Plastic tubes
&
Label stop plate

3

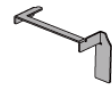

Label bracket

4



Label holder - UP

5

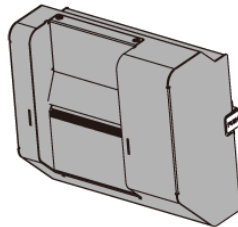

High-speed cutter

6



Label holder - Down

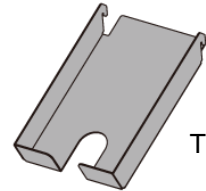

Ticket tray

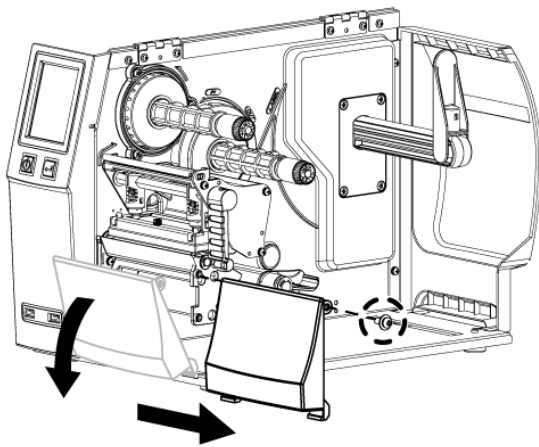

1. Loosen the screw (as the picture shows).
2. Tilt the front cover forward and move it to the

1

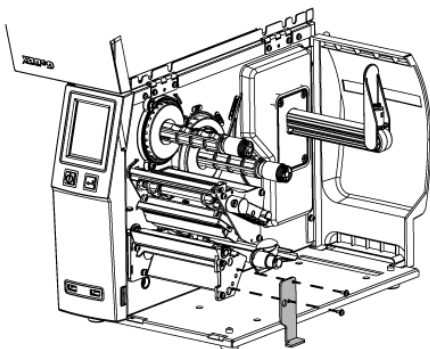

1. Assemble the Platen module bracket.

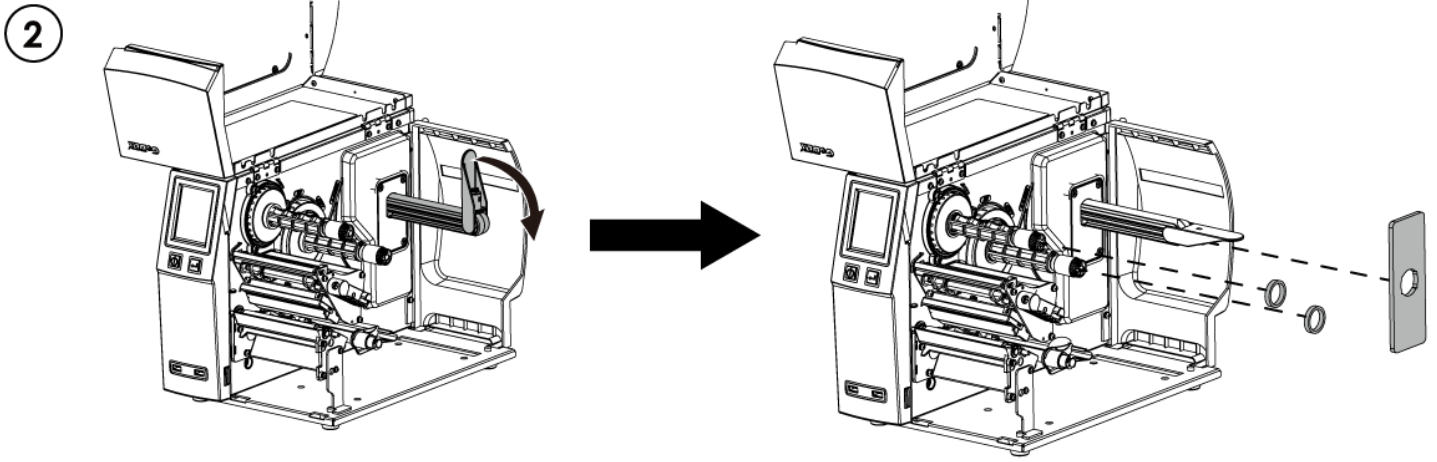

1. Assemble the label stop plate and plastic tubes.

※ (Please remove the double-sided adhesive backing paper on the label stop)

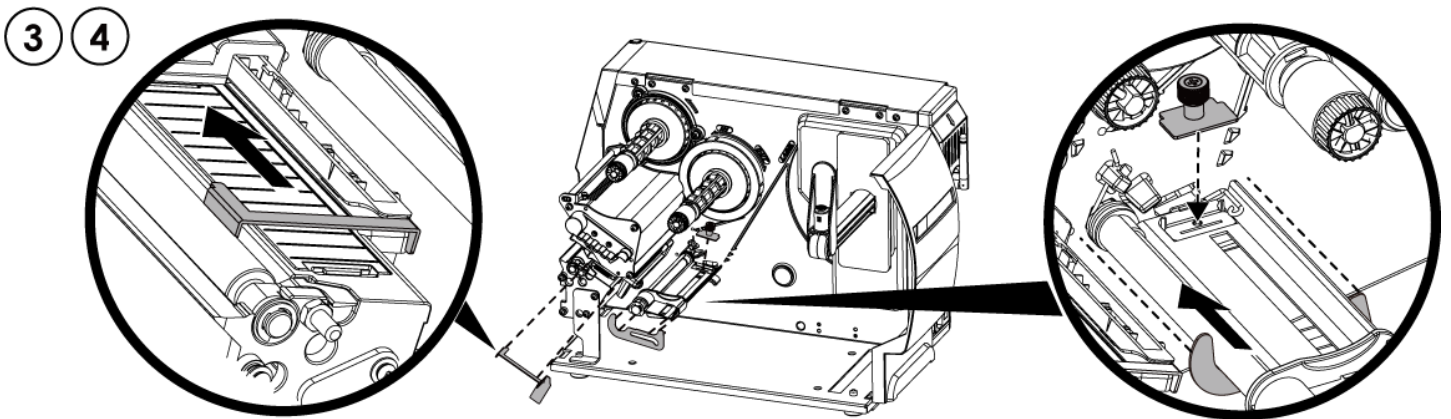

1. Install the label bracket and the label holders respectively. During the installation, push the parts to the left end and fix them with double-sided tape.

※ (Please remove the double-sided adhesive backing paper on the label bracket and label holder first.)

5

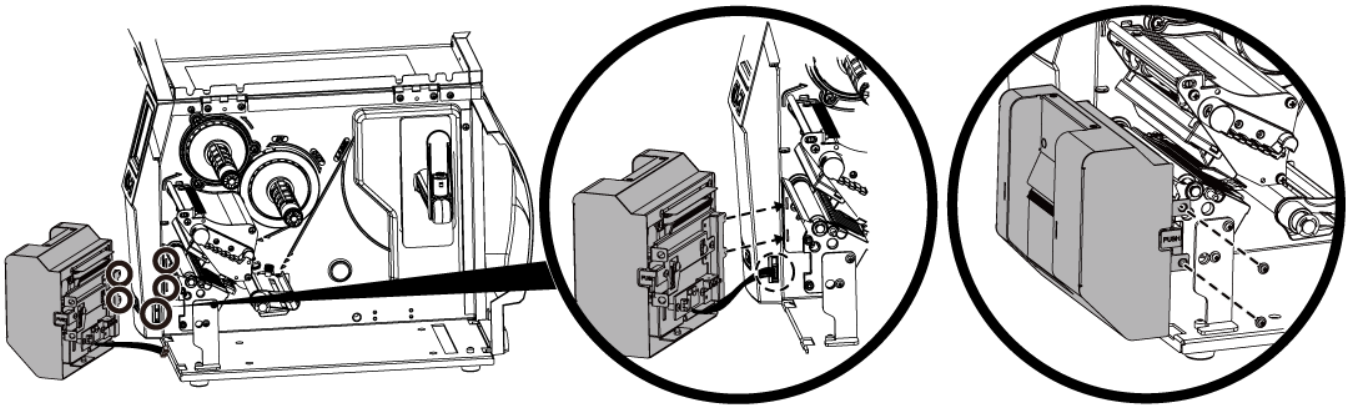

1. When installing the cutter, plug in the cable into the socket first, then insert the left side of the cutter into the mechanism fillister.(as shown in the picture)
2. Finally fix the cutter with screws(as shown in the picture)

6

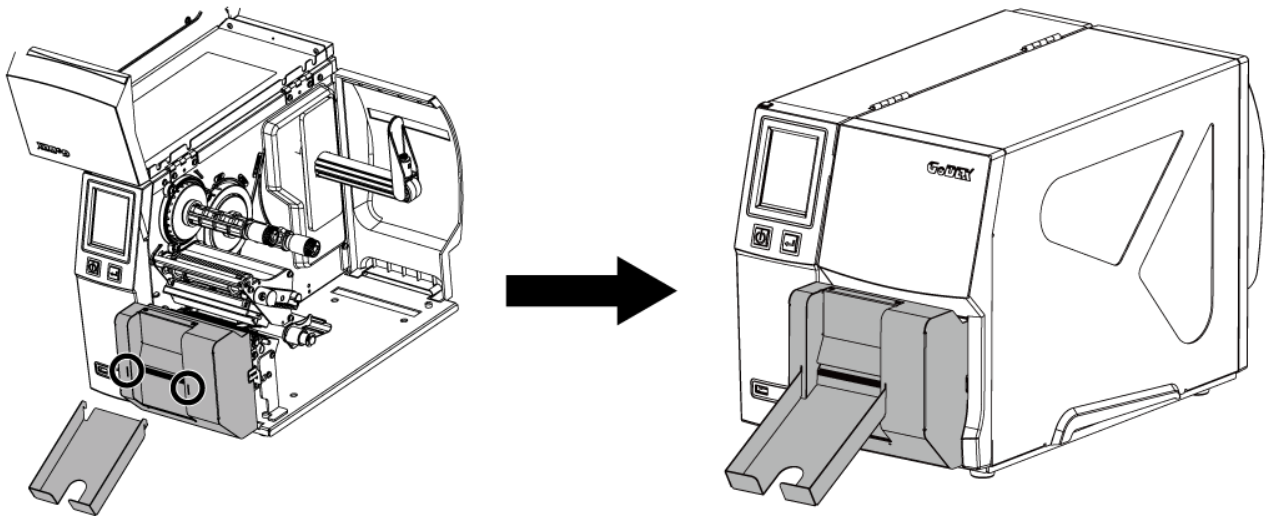

1. Snap the ticket tray to the cover of cutter to complete the installation.

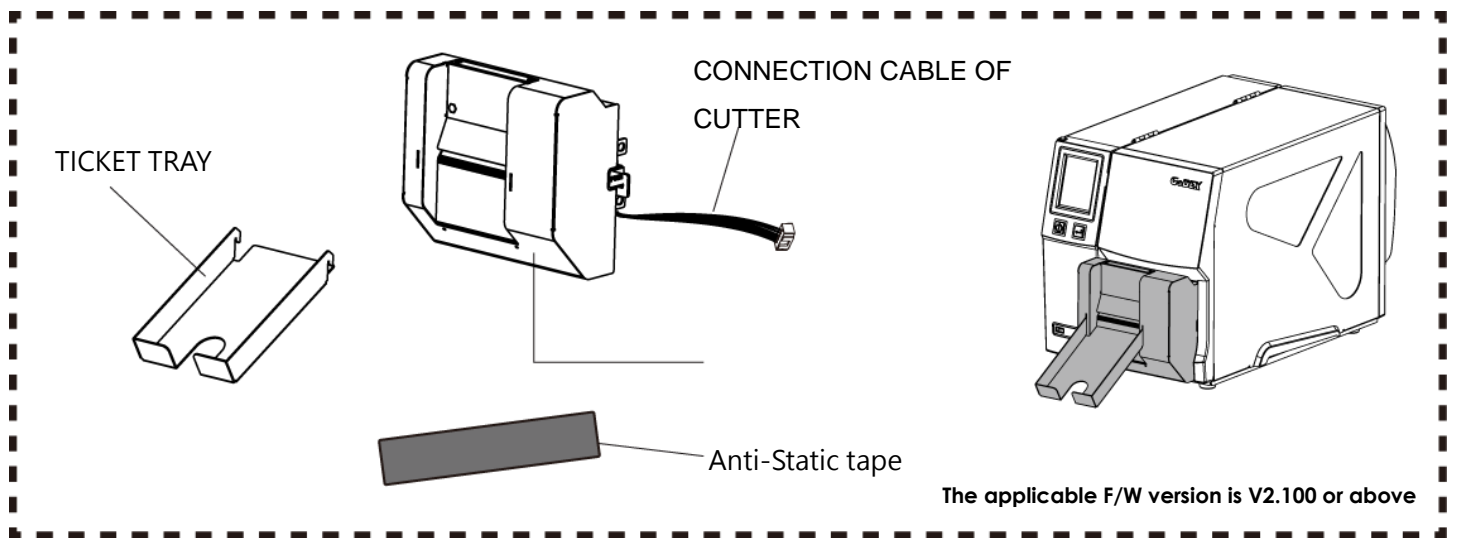

Notification

*Power off the printer and remove the cable from the electric socket before installing the cutter module.

*Labels with adhesive glue are not applicable or otherwise could result in malfunction.

*Applicable label size is at maximum width of 75mm and minimum length of 30mm.

(Use the labels with over this range will be excluded from warranty terms)

*Stop position (E value) should be set to 46 through GoLabel before using the cutter.

*After the cutter is installed, please send the following commands through Golabel to activate the high-speed cutting function.

^XSETCUT,MODE,0,1 → enables high-speed cutting function

^XSET,SMARTBACK,1 → enables pre-print function

^D1,280 → enables cutter function

*The label width setting should be 6mm wider than the original design → For example: the actual paper width is 35, Command needs to set ^W41

*The horizontal displacement needs to be set to 48

*Before using the High-Speed Cutter, the antistatic brush needed to be installed on the printing mechanism.

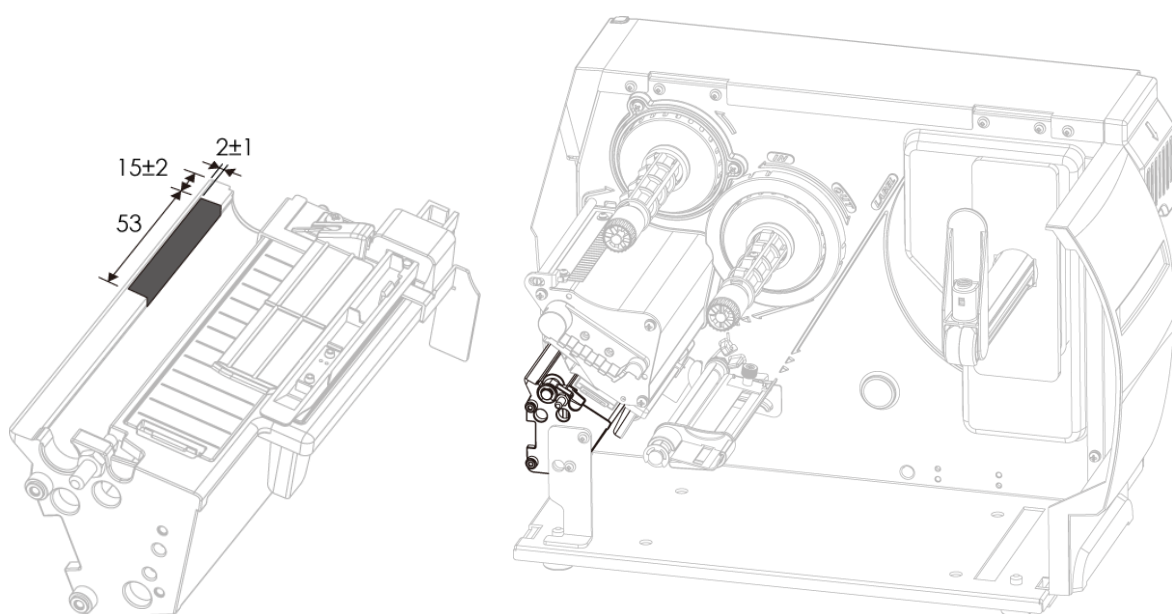

※Paste position of Anti-Static tape

Cleaning Method

1. Remove the ticket tray

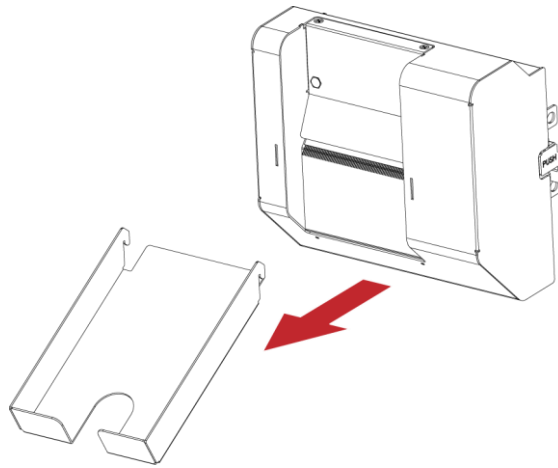

2. Remove the screws and cover.

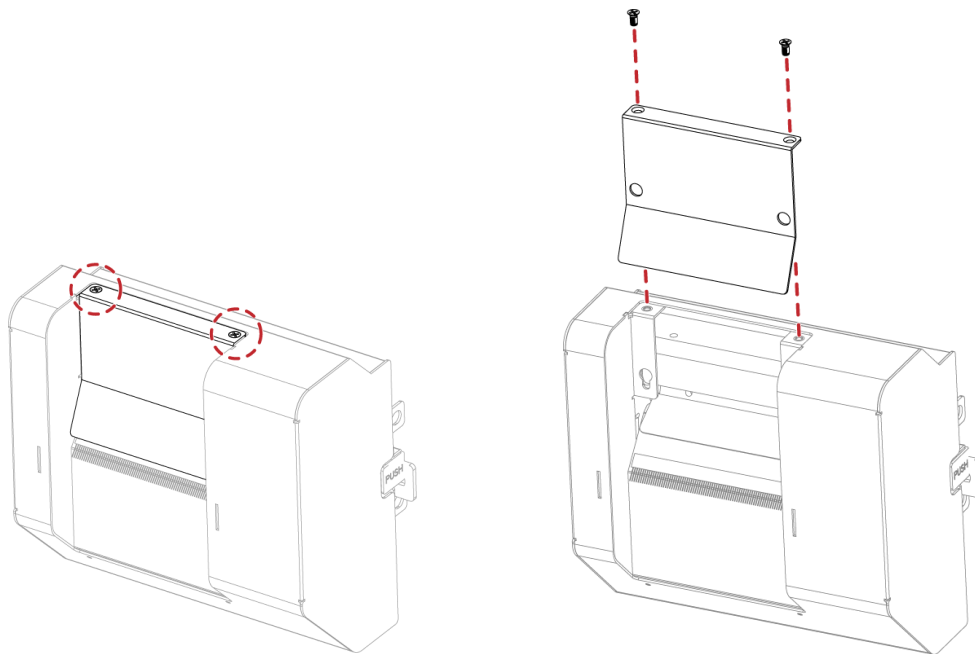

3. Wipe with a cotton swab or dry lint-free cloth

