

VPG BLH

TABLE OF CONTENTS

COMPRESSION CANISTERS

Page 192

C2P1, ALLOY STEEL



Single-column design with low deflection and trouble-free operation. High alloy steel and epoxy coated for use in harsh environments. Compact and rugged. NTEP Certified capacities range from 20,000 lb to 200,000 lb; non-NTEP Certified capacity of 300,000 lb. Complete with 10 or 35 ft of load cell cable.



Page 193

C3P1, ALLOY STEEL



Environmentally protected, single-column design provides low deflection and trouble-free operation. Compact and rugged high-alloy steel. Epoxy coated for corrosion resistance. Capacities range from 500 lb to 10,000 lb. Complete with 35 ft of load cell cable.



TENSION CANISTERS

Page 194

T2P1, ALLOY STEEL



Single-column, environmentally protected design provides low deflection and trouble-free operation. High-alloy steel and epoxy coated construction yields reliable performance in harsh environments. Designed for high-capacity tension applications. Capacities of 20,000 lb and 50,000 lb. Complete with 35 ft of load cell cable.



Page 195

T3P1, ALLOY STEEL



Features low deflection and trouble-free operation. Single-column, environmentally protected design with high-alloy steel and epoxy-coated construction for optimal performance in harsh environments. Designed for high-capacity tension operations. Capacities of 500 lb and 10,000 lb. Complete with 35 ft of load cell cable.



C2P1

Alloy Steel, Environmentally Sealed, NTEP Certified 1:4,500 Class III L Multiple Cell, IP67



Picture is a representation of actual product.

Approvals



Order Information

Load Rating	Part #	Est. Weight	Price
NTEP Certified, 10 ft Cables			
20,000 lb	21625	25 lb	\$3,595.00
50,000 lb	21626	25 lb	\$3,495.00
100,000 lb	21627	50 lb	\$3,695.00
200,000 lb	21628	110 lb	\$3,995.00
NTEP Certified, 35 ft Cables			
20,000 lb	21630	25 lb	\$3,695.00
50,000 lb	21632	25 lb	\$3,595.00
100,000 lb	21633	50 lb	\$3,795.00
200,000 lb	21634	110 lb	\$4,195.00
Non-NTEP Certified, 10 ft Cables			
300,000 lb	17670	180 lb	\$8,095.00
Non-NTEP Certified, 35 ft Cables			
300,000 lb	17671	190 lb	\$8,195.00

Dimensions

Rated Capacity	A	B	C	D	E	F	G	H	J	K	L
lb/in											
20,000 to 50,000	7.50	4.50	2.25	1.25	0.50	0.75	2.50	6.00	—	2.38	3/8-24 UNF × 3/8 DP
100,000	9.13	6.00	3.13	1.75	0.63	1.06	2.50	12.00	—	4.00	1/2-20 UNF × 3/4 DP
200,000	11.63	8.00	4.50	2.50	0.63	1.06	3.50	12.00	—	5.50	5/8-18 UNF × 1 DP
300,000	14.00	10.00	5.00	3.00	0.75	1.31	4.31	15.00	8.00	5.50	3/4-16 UNF × 1 1/4 DP

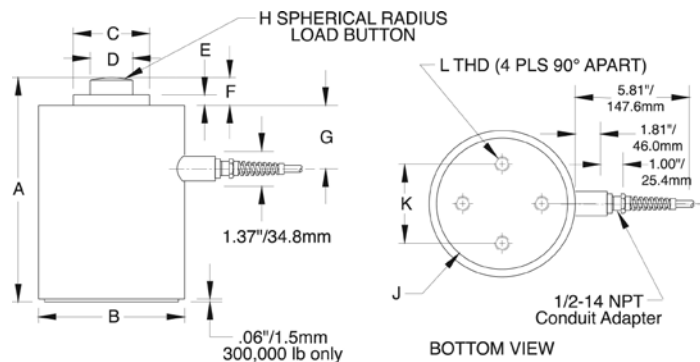

Interchangeable Products

- FAIRBANKS®
3-38065-X, 3-38066-X
- STREETER RICHARDSON®
2011611, 2011612
- STREETER RICHARDSON
2011613, 2011614, 2011617
- METTLER TOLEDO®
10049200A, 10014900A
- METTLER TOLEDO
10011900A, 10049300A

Specifications

- Full Scale Output:**
2.0 mV/V
- Output Resistance:**
350 (± 3.5) ohm
- Input Resistance:**
350 (± 3.5) ohm
- Material/Finish:**
High-alloy steel, epoxy coated
- Temperature:**
Compensated range
14 °F to 104 °F (-10 °C to 40 °C)
Operating range
0 °F to 150 °F (-18 °C to 65 °C)
- Seal Type:**
NEMA Type 6 Environmentally sealed, IP67
- Safe Overload:**
150% full scale
- Rated Excitation:**
5 to 10 VDC (20 V maximum)
- Nonlinearity:**
0.03% full scale
- Hysteresis:**
0.02% full scale
- Insulation Resistance:**
5,000 megohm
- Deflection at Capacity:**
20,000 lb: 0.0075 in
30,000 lb: 0.0075 in
50,000 lb: 0.0065 in
100,000 lb: 0.0075 in
200,000 lb: 0.0070 in
300,000 lb: 0.012 in
- Cable Length:**
10 ft
35 ft
- Cable Color Code:**
Green +Excitation
Black -Excitation
White +Signal
Red -Signal
Yellow Shield
- Warranty:**
Three-year limited
- Approvals:**
NTEP
FM

VPG BLH



Picture is a representation of actual product.

Approvals



Order Information

Load Rating	Part #	Est. Weight	Price
500 lb	17672	10 lb	\$3,595.00
1,000 lb	17673	10 lb	\$3,595.00
2,000 lb	17674	10 lb	\$3,595.00
3,000 lb	17675	10 lb	\$3,595.00
5,000 lb	17676	15 lb	\$3,695.00
10,000 lb	17677	15 lb	\$3,695.00

Dimensions

Rated Capacity	D	D1	D3	D4	F	H	H3	H4	L	T
lb/in										
500 to 3,000	3.50	0.62	1.25	—	2.25	4.56	0.38	0.25	—	1/2-20 UNF × 0.50 DP
5,000 to 10,000	3.50	1.06	2.50	1.75	2.66	5.94	0.62	0.38	0.50	1-14 UNS × 1.25 DP

HOLES CAN BE DRILLED WITHIN THIS AREA TO RECEIVE LOCKING SCREWS. MAX. DEPTH OF HOLES IS "L" DIM.

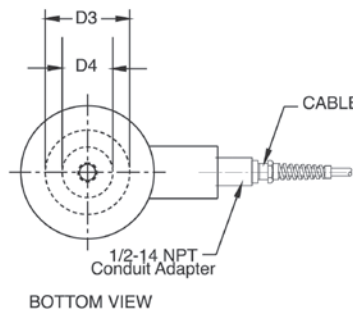
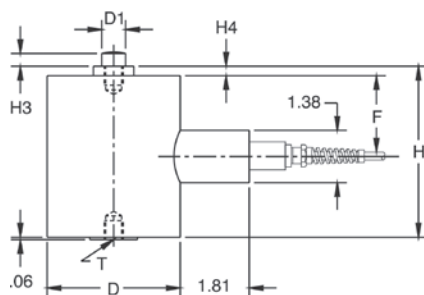

Interchangeable Products

- FAIRBANKS®
3-38054-X
- METTLER TOLEDO®
1004400A, KN713700
- METTLER TOLEDO
KB200570, 10049100A

Specifications

- Full Scale Output:**
3.0 mV/V
- Output Resistance:**
350 (± 3.5) ohm
- Input Resistance:**
350 (± 3.5) ohm
- Material/Finish:**
High-alloy steel, epoxy coated
- Temperature:**
Operating range
0 °F to 150 °F (-18 °C to 65 °C)
- Seal Type:**
NEMA Type 6 Environmentally sealed, IP67
- Safe Overload:**
150% full scale
- Rated Excitation:**
5 to 10 VDC (20 V maximum)
- Nonlinearity:**
0.05% full scale
- Hysteresis:**
500 lb: 0.05% full scale
1,000 to 10,000 lb: 0.02% full scale
- Insulation Resistance:**
5,000 megohm
- Deflection at Capacity:**
500 lb: 0.007 in
1,000 lb: 0.006 in
2,000 lb: 0.005 in
3,000 lb: 0.005 in
5,000 lb: 0.007 in
10,000 lb: 0.005 in
- Cable Length:**
35 ft
- Cable Color Code:**
Green +Excitation
Black -Excitation
White +Signal
Red -Signal
Yellow Shield
- Warranty:**
Three-year limited
- Approvals:**
FM



T2P1

Alloy Steel, Environmentally Sealed, IP67



Picture is a representation of actual product.

Approvals



Order Information

Load Rating	Part #	Est. Weight	Price
20,000 lb	17660	30 lb	\$3,695.00
50,000 lb	17661	65 lb	\$3,895.00

Dimensions

Rated Capacity	A	B	C	D	E	F	G	H	I	J	K	L	M
lb/in													
20,000	8.50	2.63	2.75	0.50	1.00	3.38	1.38	1.81	1.00	5.81	4.00	5.00	1 1/2-12 UNF × 2 DP
50,000	11.44	3.75	4.00	0.63	1.00	5.00	1.38	1.81	1.00	5.81	5.75	6.50	2-12 UNF × 2.63 DP

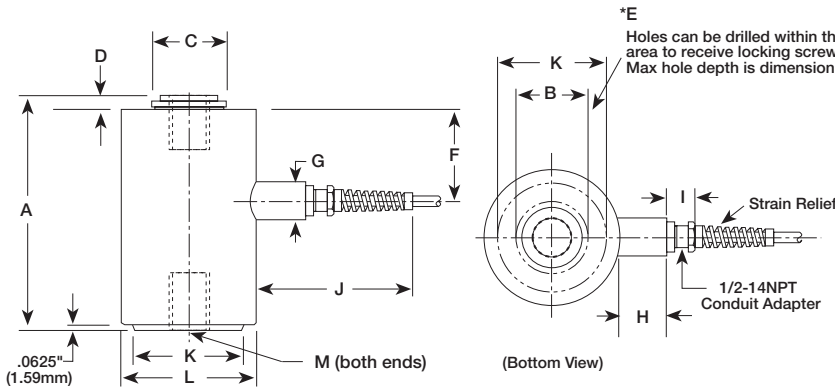

Interchangeable Products

FAIRBANKS®
657090, 657091
 STREETER RICHARDSON®
2011711, 2011712

Specifications

- Full Scale Output:**
2.0 mV/V
- Output Resistance:**
350 (± 3.5) ohm
- Input Resistance:**
350 (± 3.5) ohm
- Material/Finish:**
High-alloy steel, epoxy coated
- Temperature:**
Operating range
0 °F to 150 °F (-18 °C to 65 °C)
- Seal Type:**
Environmentally sealed, IP67
- Safe Overload:**
150% full scale
- Rated Excitation:**
5 to 10 V DC (20 V maximum)
- Combined Error:**
±0.03% full scale
- Repeatability:**
0.02% full scale
- Insulation Resistance:**
5,000 megohm
- Deflection at Capacity:**
20,000 lb: 0.0075 in
50,000 lb: 0.0100 in
- Cable Length:**
35 ft
- Cable Color Code:**
Green +Excitation
Black -Excitation
White +Signal
Red -Signal
Yellow Shield
- Warranty:**
Three-year limited
- Approvals:**
FM



Picture is a representation of actual product.

Approvals



Order Information

Load Rating	Part #	Est. Weight	Price
500 lb	17654	10 lb	\$3,595.00
1,000 lb	17655	10 lb	\$3,595.00
2,000 lb	17656	10 lb	\$3,595.00
3,000 lb	17657	10 lb	\$3,595.00
5,000 lb	17658	15 lb	\$3,695.00
10,000 lb	17659	15 lb	\$3,695.00

Dimensions

Rated Capacity	A	B	C	D	E	F	G	H	I	J	K	L	M
500 to 3,000 lb/in	4.56	—	1.06	0.25	—	2.25	1.38	1.81	1.00	5.81	1.25	3.50	1/2-20 UNF × 0.5 DP
5,000 to 10,000 lb/in	5.93	1.75	1.87	0.38	0.50	2.66	1.38	1.81	1.00	5.81	2.50	3.50	1-14 UNS × 1.25 DP

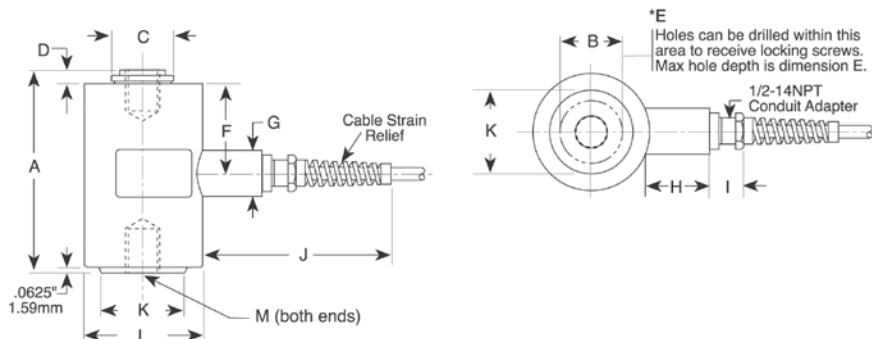

Interchangeable Products

FAIRBANKS®

3-39897-X, 3-40766-X

STREETER RICHARDSON®

20117XX

METTLER TOLEDO®

10048X00A, KN75066

Specifications

Full Scale Output:

3.0 mV/V

Output Resistance:

350 ohm (+/- 3.5)

Input Resistance:

350 ohm (+/- 3.5)

Material/Finish:

High-alloy steel, epoxy coated

Temperature:

Operating range
0 °F to 150 °F (-18 °C to 65 °C)

Seal Type:

Environmentally sealed, IP67

Safe Overload:

150% full scale

Rated Excitation:

5 to 10 V DC (20 V maximum)

Nonlinearity:

0.05% full scale

Hysteresis:

500 lb: 0.05% full scale
1,000 to 10,000 lb: 0.02% full scale

Insulation Resistance:

5,000 megohm

Deflection at Capacity:

500 lb: 0.007 in
1,000 lb: 0.006 in
2,000 lb: 0.005 in
3,000 lb: 0.005 in
5,000 lb: 0.007 in
10,000 lb: 0.005 in

Cable Length:

35 ft

Cable Color Code:

Green +Excitation
Black -Excitation
White +Signal
Red -Signal
Yellow Shield

Warranty:

Three-year limited

Approvals:

FM

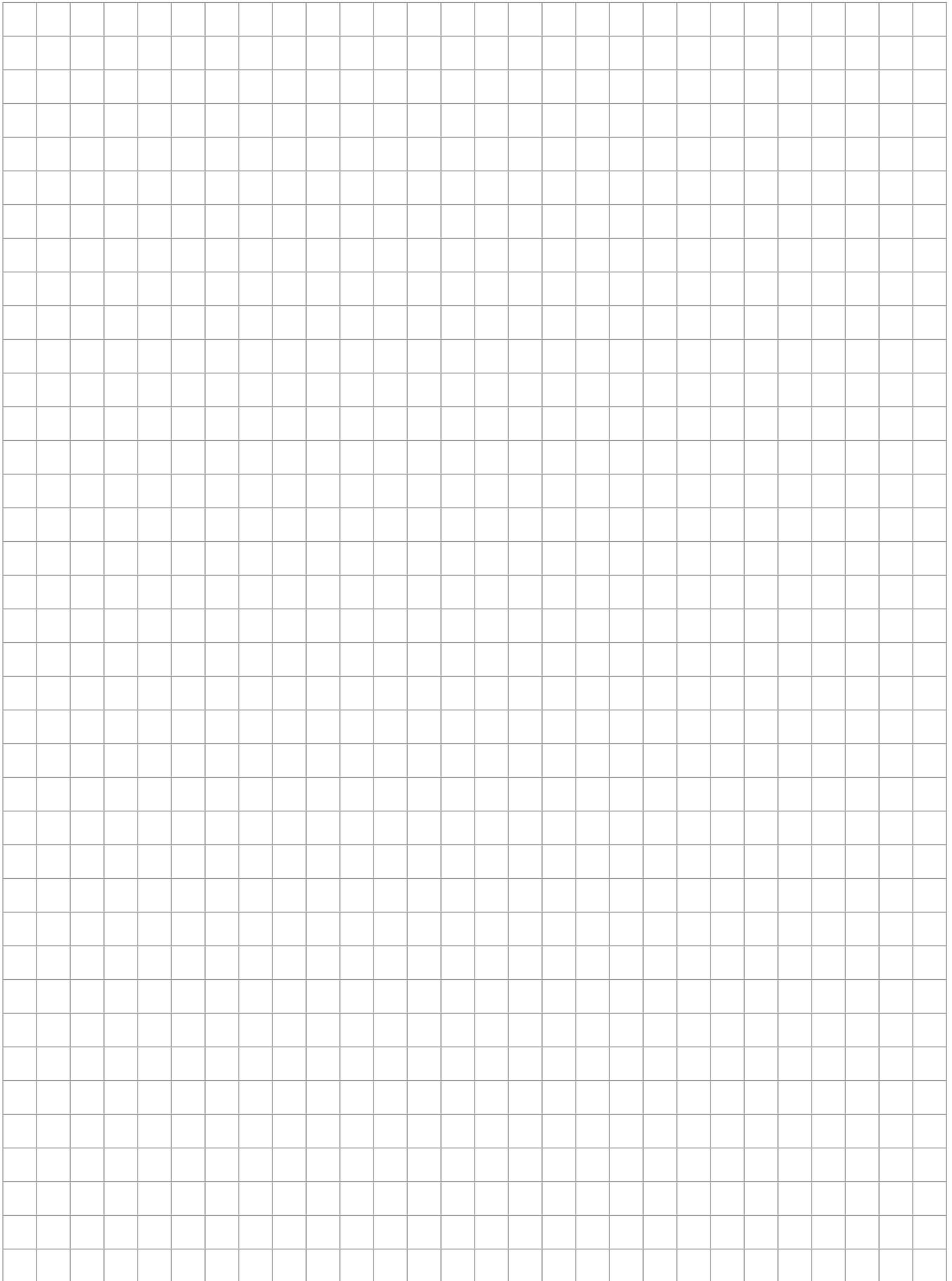

VPG BLH

