

RL1200 EM

Electromechanical Portable Beam Scale and 380 Indicator



Approvals



Part Number/Price

Part #	Overall Size (W x L x H)	Capacity	Est. Weight	Price
216112	Portable beam with 380 Synergy	1,000 lb x 0.5 lb	200 lb	Consult

Options/Accessories

Part #	Description	Price
206433†	380 indicator external AC adapter	Consult

Standard Features

Scale

- NTEP Certified
- 1,000 lb capacity
- Heavy-duty wheels and handle for portability

380 Indicator

- LCD display
- Alkaline battery powered
- Push-button and keyed tare
- Two communication ports
- Five tactile buttons
- Configurable print formats

RL1200 EM Specifications

Construction:

Cast-iron platform, base and levers

Platform Dimensions:

(L x W)
24 x 18 in

Capacity:

1,000 lb

Approvals:

NTEP 93-004 Class III 2,000d

Warranty:

One-year limited

380 Specifications

Power:

Batteries: 4 alkaline C-cell (not included)
Optional: 115/230VAC to 12VDC adapter

Battery Life:

100 hours with 1 x 350 ohm load cell, no backlight
45 hours with 4 x 350 ohm load cells, low backlight
20 hours with 8 x 350 ohm load cells, low backlight

Communication Ports:

One RS-232 (three-wire)
One USB 2.0

Annunciators:

g, lb, t, tn, kg, oz, battery level, PT, LT, gross, zero, unstable, net

Display:

Six 1 in (25 mm) tall, LCD digits

Keys/Buttons:

5 tactile buttons

Rating/Material:

IP66, 304 Stainless steel

Approvals:

NTEP 21-051, Class III/IIIL, 10,000 d
Measurement Canada AM-6184
cULus
CE marked

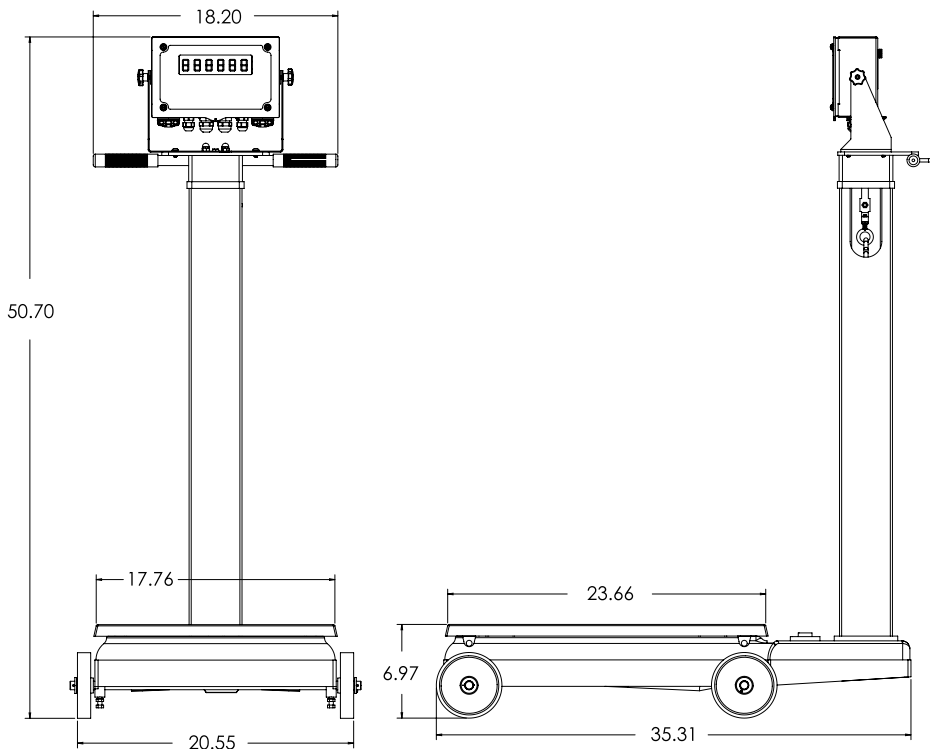

FLOOR SCALES