

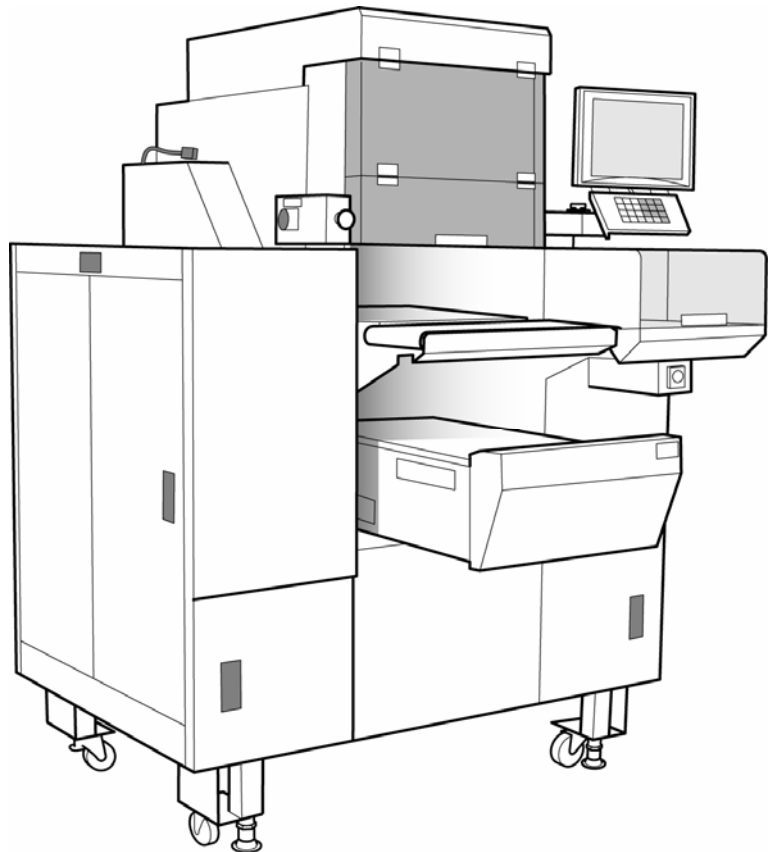

OMNi-4000ST

Service Manual



p/n 93978

Rev. April 2007

IMPORTANT

- Do not carry out installation, operation, service, or maintenance until thoroughly understanding the contents of this manual.
- Keep this manual available at all times for installation, operation, service, and maintenance.

ISHIDA CO., LTD.

© Ishida Co., Ltd. 2005

All rights are reserved. No part of this publication may be reproduced, stored in a retrieval system, or transmitted in any form or by any means mechanical, electronic, photocopying, recording, or otherwise without prior written permission of Ishida. No patent liability is assumed with respect to the use of the information contained herein. Moreover, because Ishida is constantly striving to improve its high-quality products, the information contained in this manual is subject to change without notice. Every precaution has been taken in the preparation of this manual. Nevertheless, Ishida assumes no responsibility for errors or omissions. Neither is any liability assumed for damages resulting from the use of the information contained in this publication.

IMPORTANT NOTICE

Thank you for purchasing the ISHIDA OMNi-4000ST.

This manual explains the procedures to perform installation, operation, service, or maintenance of the machine.

Those who handle the machine must be aware of the hazards involved. These dangers may not be obvious, so it is imperative to follow the instructions detailed in this manual when installing, operating, inspecting, or servicing the machine. Therefore, we recommend that you thoroughly read and understand this manual before installing, operating, inspecting, or servicing the machine, and keep this manual in a safe place where you can refer to it whenever necessary.

ISHIDA is not liable for any damage, loss or injury that results from incorrect operation, insufficient caution, unauthorized modifications to the machine, or failure to follow the instructions contained in this manual.

In the recent weighing industry, the latent hazards involved with handling the machine have increased due to new materials, new processing methods, and higher processing speeds, and it is impossible to predict all of the possible dangers.

Likewise, there are far too many operations which cannot or should not be performed to fully describe all of them in the manual. Please assume that any handling or operation not specifically described in this manual should never be performed.

Safety countermeasures should be carefully considered and implemented before performing any installation, operation, inspection, or maintenance procedure not specifically described in this manual or indicated on the machine itself.

CHANGE IN SPECIFICATIONS

Machine specifications and accessories may be changed at any time due to improvements or other reasons. Consult with your ISHIDA representative at any time to confirm the actual specifications of the purchased machine.

ERRORS AND OMISSIONS

The information in this manual has been carefully checked and is believed to be accurate. However, please understand that the descriptions in this manual may not agree with the actual machine due to machine improvements. The information is subject to change without prior notice in the future. ISHIDA assumes no responsibility for clerical, typographical or proofreading errors, or omissions.

LIMITATIONS OF LIABILITY

ISHIDA assumes no responsibility for special, indirect, or consequential damages, loss of profits or commercial loss in any way connected with the machine, whether such claim is based on contract, warranty, negligence, or strict liability.

ISHIDA shall assume responsibility for problems with the machine or the system based on an individual maintenance contract. However, ISHIDA shall not be responsible for secondary problems. ISHIDA assumes no responsibility for the user's programming of this machine, or any consequence thereof.

In no event shall ISHIDA be responsible for warranty, repair, or other claims regarding the machine unless ISHIDA's analysis confirms that the machines were properly handled, stored, installed, and maintained and not subject to contamination, abuse, misuse, or inappropriate modification or repair.

SAFETY CONSIDERATIONS

This service manual contains information necessary for servicing the OMNi-4000ST. It is strongly advised that the following safety measures must be observed to ensure the safe servicing of the machine:

- **Servicing is to be done by qualified service personnel only**

These service instructions are for use by qualified service personnel who fully understand the potential hazards involved. To avoid any possible danger, do not perform any service procedures unless qualified to do so.

- **Perform only the specified service procedures**

To ensure personal safety, do not perform any service procedures that are not specifically mentioned in this manual.

- **Properly ground machinery**

As a Class 1 electrical device, this machine requires protective grounding for safe operation. To avoid any potential electrical shock, securely attach the protective ground wire to the main grounding provision.

- **Avoid servicing while power is being supplied**

The power supply to the machine is disconnected only when the electrical plug is removed from the electrical outlet. For protection against electrical shock, remove the plug before performing any servicing to the machine. Servicing the machine while power is being supplied and opening or removing covers or enclosures should be avoided as much as possible. When servicing cannot be performed by any other means, service personnel should take precautions against the danger of electrical shock or other potential hazards involved.

- **Take precaution against residual electrical charge hazard**

Capacitors inside the machine may still hold an electrical charge even after power is disconnected.

- **Use the same type of fuses and components for replacement parts**

To avoid the potential hazards involved, do not replace fuses or components with types other than those specified in the parts list for this machine.

MAINTENANCE PRECAUTIONS

To ensure the safety and long operating life of this machine, it is important to observe the following precautions:

- Keep the area around the machine clear of any dust and debris.
- Do not leave screws or other foreign objects in the machine after performing routine maintenance since this can cause major damage to the machine when the electrical switch is turned on.
- Always remove wires by holding the connector and pulling to disconnect. Do not disconnect by pulling on the wires themselves since this may cause a wire to snap or damage the connection.
- Before disassembling or adjusting this machine, make sure you thoroughly understand and follow each step in the order indicated in this manual.

TABLE OF CONTENTS

Chapter 1 PRODUCT OVERVIEW

1.1	NAME OF EACH EXTERNAL UNIT	1-2
1.2	NAME OF EACH INTERNAL UNIT	1-3
1.3	NAME OF EACH MOTOR	1-4
1.4	NAME OF EACH POWER SUPPLY	1-5
1.5	FUNCTION OF EACH UNIT	1-6
1.6	WARNING SYMBOLS	1-8
1.7	BASIC SPECIFICATIONS	1-9

Chapter 2 INSTALLATION

2.1	INSTALLATION PRECAUTIONS	2-2
2.2	INSTALLATION SPACE	2-6
2.3	SAFETY SWITCHES	2-7
2.4	MAIN POWER ON/OFF	2-8
2.5	LABEL SETTING	2-9
2.6	FILM LOADING METHOD	2-11
2.7	HEATER TEMPERATURE ADJUSTMENT	2-18

Chapter 3 TEST MODE

3.1	STARTING PROCEDURE	3-2
3.2	TEST MENU	3-4
3.3	KEY CHECK MENU	3-6
3.4	MACHINE SETTING	3-9
3.5	SELF DIAGNOSTIC	3-12
3.6	MEMORY INITIALIZATION	3-13
3.7	DISPLAY CHECK	3-14
3.8	SCALE CALIBRATION	3-15
3.9	PRINT ADJUSTMENT	3-19
3.10	ROM VERSION DISPLAY	3-25
3.11	COMMUNICATION CHECK	3-26
3.12	OPTION CHECK	3-27
3.13	MEMORY DATA CHANGE	3-28
3.14	TIME AND DATE SETTING	3-31
3.15	PROGRAM DOWNLOADING	3-32
3.16	WRAPPER / APPLICATOR ADJUSTMENT	3-34
3.17	WRAPPER SETUP	3-36
3.18	APPLICATOR ADJUSTMENT	3-38

Chapter 4 SYSTEM MODE

4.1	STARTING PROCEDURE	4-2
4.2	SYSTEM MENU	4-4
4.3	TCP/IP SETUP	4-6
4.4	SYSTEM DATA SETUP	4-8
4.5	AUTO PROGRAM SETTING	4-10
4.6	LABEL PRINT COMBINATION SETUP	4-13

4.7	FORMAT SETTING	4-23
4.8	PRINT ITEM SETTING	4-24
4.9	FILE CHECK	4-26
4.10	FILE INPUT/OUTPUT	4-28
4.11	FREE MESSAGE NAME REGISTRATION	4-32
4.12	LINK MASTER ERROR SETUP	4-33
4.13	WRAPPER SETTING	4-34
4.14	DISPLAY ERROR LOG	4-35
4.15	SRAM DATA INPUT/OUTPUT	4-39
4.16	FILE TRANSFER MENU	4-45

Chapter 5 SETUP MODE

5.1	STARTING PROCEDURE	5-2
5.2	SETUP MENU	5-4
5.3	EXPIRY DATE SETTING	5-6
5.4	PASSWORD SETTING	5-9
5.5	WORDWRAP WIDTH SETTING	5-10
5.6	REFERENCE DATA SETUP	5-11
5.7	TOTAL ADD SETTING	5-13
5.8	BARCODE SETUP	5-15
5.9	ITEM CODE SETTING	5-17
5.10	PLU DEFAULT DATA SETTING	5-18
5.11	PLU UPDATE SETTING	5-21
5.12	KEY LOCK SETTING	5-23
5.13	PLU DATE/TIME SETTING	5-26
5.14	PLU OPERATION SETTING	5-27
5.15	ERROR SETTING	5-28
5.16	PRINT SELECT SETTING	5-29

Chapter 6 TRAY PROGRAM

6.1	TRAY PROGRAM (LABEL)	6-2
6.2	LABEL POSITION ADJUSTMENT	6-3
6.3	TRAY PROGRAM (DETAIL)	6-4

Chapter 7 LABEL ADJUSTMENT

7.1	LABEL GUIDE WIDTH ADJUSTMENT	7-2
7.2	LABEL SENSOR POSITION CHANGE	7-3
7.3	G. ROLLER/LABEL PRESS BRACKET POSITION	7-4
7.4	PRINTING ADJUSTMENT	7-6
7.5	FEEDING STOP AMOUNT	7-8
7.6	LABEL EDGE CUTTING	7-9
7.7	LABEL STANDBY PART	7-10
7.8	PEEL SENSOR OPTICAL AXIS ADJUSTMENT	7-13
7.9	HEAD-UP SENSOR ADJUSTMENT	7-14

Chapter 8 LOAD CELL UNIT

8.1	MAIN PARTS	8-2
8.2	LOAD CELL UNIT REPLACEMENT	8-3
8.3	SPAN ADJUSTMENT	8-6

Chapter 9 WRAPPING KNOWLEDGE

9.1	TRAY PUSHER SPEED	9-2
9.2	APPROPRIATE FILM WIDTH	9-2
9.3	WRAPPING SPEED	9-2
9.4	SENSOR ORIGIN POSITION ADJUSTMENT.....	9-3
9.5	TRAY SURFACE FILM TENSION ADJUSTMENT	9-4
9.6	SETTINGS TRAY WIDTH AND LENGTH.....	9-5
9.7	ADJUSTMENT OF SENSOR ORIGIN POSITION	9-6
9.8	SELECTION OF FILM WIDTH	9-7
9.9	ADJUSTMENT OF LIFT HEAD HEIGHT.....	9-8
9.10	FILM PINCH SOLENOID POSITION ADJUSTMENT.....	9-10

Chapter 10 PRINTER PARTS REPLACEMENT

10.1	THERMAL HEAD REPLACEMENT.....	10-2
10.2	PEEL SENSOR REPLACEMENT	10-5
10.3	LABEL SENSOR / HEAD-UP SENSOR REPLACEMENT	10-7
10.4	PRINT ROLLER REPLACEMENT.....	10-9

Ch11 ELECTRICAL SIGNALS

11.1	MAIN PC BOARD (P-910H-2)	11-2
11.2	WRAPPER MAIN BOARD (P-857*)	11-6
11.3	WRAPPER I/O BOARD (P-858A-*) A TYPE.....	11-11
11.4	WRAPPER I/O BOARD (P-858A-*) B TYPE	11-15
11.5	WRAPPER I/O BOARD (P-858A-*) C TYPE	11-19
11.6	EMERGENCY STOP BUTTON (IDEC'2B[HW1B-V402R]:064-9296-**)	11-22
11.7	SAFETY COVER SWITCH.....	11-23
11.8	SAFETY SWITCH ASSY. (091-0690-**)	11-24
11.9	DISCHARGE PUSHER	11-25
11.10	THERMAL PC BOARD (P-909C-3)	11-26
11.11	APPLICATOR CONTROL PC BOARD (P-916B).....	11-29
11.12	CONTROL CONSOLE PC BOARD (P-917-1).....	11-34
11.13	CONNECTOR RELAY PC BOARD (P-918A-1).....	11-36
11.14	DISPLAY JUNCTION PC BOARD (P-919B-3)	11-38
11.15	THERMAL HEAD RELAY PC BOARD (P-925*)	11-39
11.16	SCALE PC BOARD (P-930A-1)	11-40
11.17	LAN PC BOARD (P-967-1).....	11-42
11.18	SW POWER SUPPLY (DL912W) U220	11-43
11.19	SW POWER SUPPLY (DL912W-1) U51	11-45

Chapter 12 DIAGRAMS

12.1	APPEARANCE DIAGRAM	12-2
12.2	WIRING DIAGRAM	12-3
12.3	CONTROL WIRING DIAGRAM	12-4

Chapter 13 PARTS LIST & DIAGRAMS

13.1	RECOMMENDED INDENTORY PARTS LIST	13-2
13.2	PREVENTIVE MAINTENANCE PARTS LIST	13-7
13.3	CONNECTION ASSEMBLY DIAGRAM.....	13-31
13.4	INSIDE COVER ASSEMBLY DIAGRAM	13-32
13.5	FILM PRESS ASSEMBLY DIAGRAM.....	13-33
13.6	TRAY STOPPER ASSEMBLY DIAGRAM.....	13-34
13.7	PRINTER FRAME ASSEMBLY DIAGRAM.....	13-35
13.8	TRAY PRESS ASSEMBLY DIAGRAM.....	13-36
13.9	UPPER COVER ASSEMBLY DIAGRAM.....	13-37
13.10	LOWER COVER ASSEMBLY DIAGRAM	13-38
13.11	POWER SUPPLY ASSEMBLY DIAGRAM.....	13-39
13.12	MAIN BODY ASSEMBLY DIAGRAM.....	13-40
13.13	CONTROL ASSEMBLY DIAGRAM.....	13-41
13.14	FIXED APPLICATOR ASSEMBLY DIAGRAM	13-42

Chapter 14 ERROR SCREEN

14.1	ERROR CODE (0100 -).....	14-2
14.2	ERROR CODE (0200 -).....	14-4
14.3	ERROR CODE (0300 -).....	14-8
14.4	ERROR CODE (0400 -).....	14-17
14.5	ERROR CODE (0600 -).....	14-27
14.6	ERROR CODE (0700 -).....	14-30
14.7	ERROR CODE (0800 -).....	14-33
14.8	ERROR CODE (1300 -).....	14-34
14.9	ERROR CODE (1400 -).....	14-35
14.10	ERROR CODE (1500 -).....	14-36
14.11	ERROR CODE (1600 -).....	14-38
14.12	ERROR CODE (2000 -).....	14-39
14.13	ERROR CODE (9000 -).....	14-41

Chapter 15 ERROR CODES AND TROUBLESHOOTING

15.1	ERROR CODE (0100 -).....	15-2
15.2	ERROR CODE (0200 -).....	15-3
15.3	ERROR CODE (0300 -).....	15-6
15.4	ERROR CODE (0400 -).....	15-10
15.5	ERROR CODE (0600 -).....	15-20
15.6	ERROR CODE (0700 -).....	15-24
15.7	ERROR CODE (1400 -).....	15-27
15.8	ERROR CODE (1600 -).....	15-28

1

PRODUCT OVERVIEW

CONTENTS

1.1	NAME OF EACH EXTERNAL UNIT	1-2
1.2	NAME OF EACH INTERNAL UNIT.....	1-3
1.3	NAME OF EACH MOTOR	1-4
1.4	NAME OF EACH POWER SUPPLY	1-5
1.5	FUNCTION OF EACH UNIT	1-6
1.6	WARNING SYMBOLS	1-8
1.7	BASIC SPECIFICATIONS	1-9

1.1 NAME OF EACH EXTERNAL UNIT

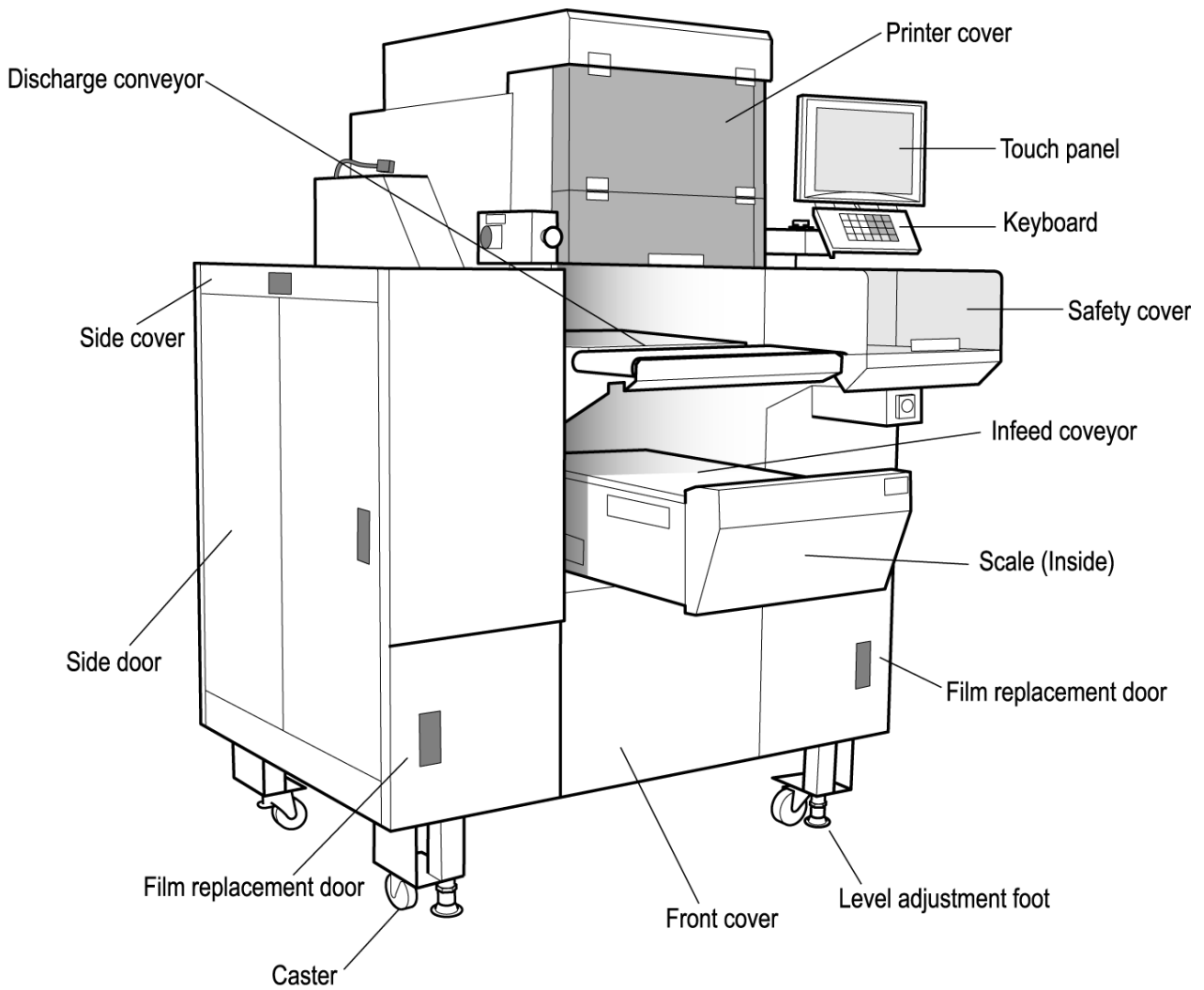

1.2 NAME OF EACH INTERNAL UNIT

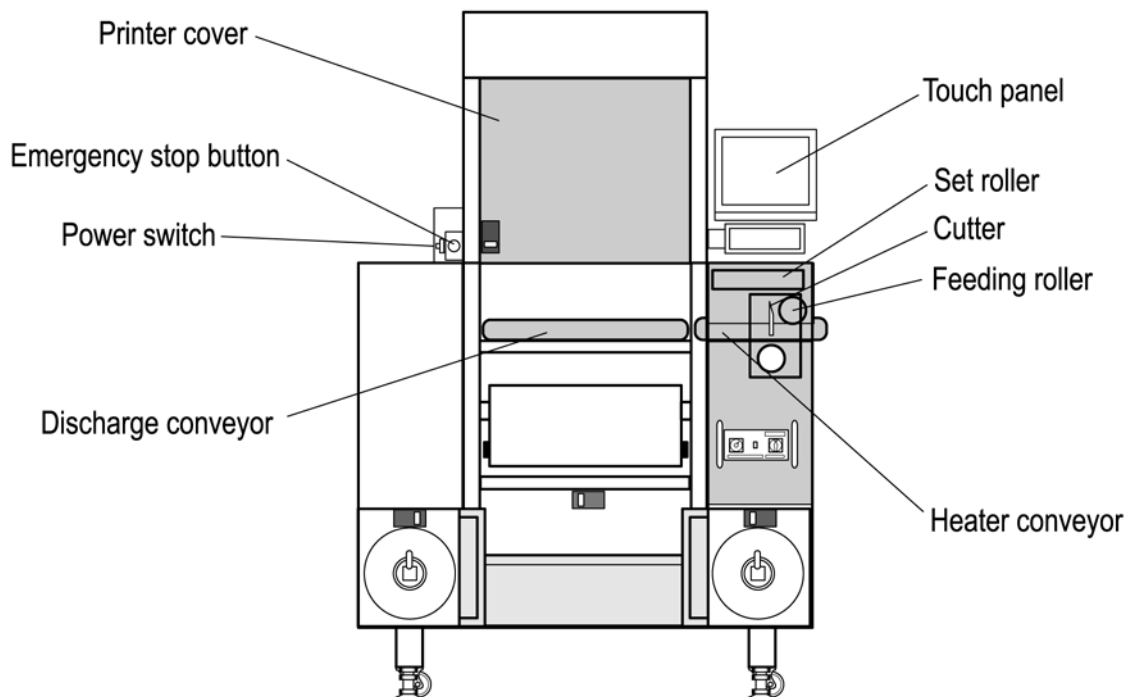
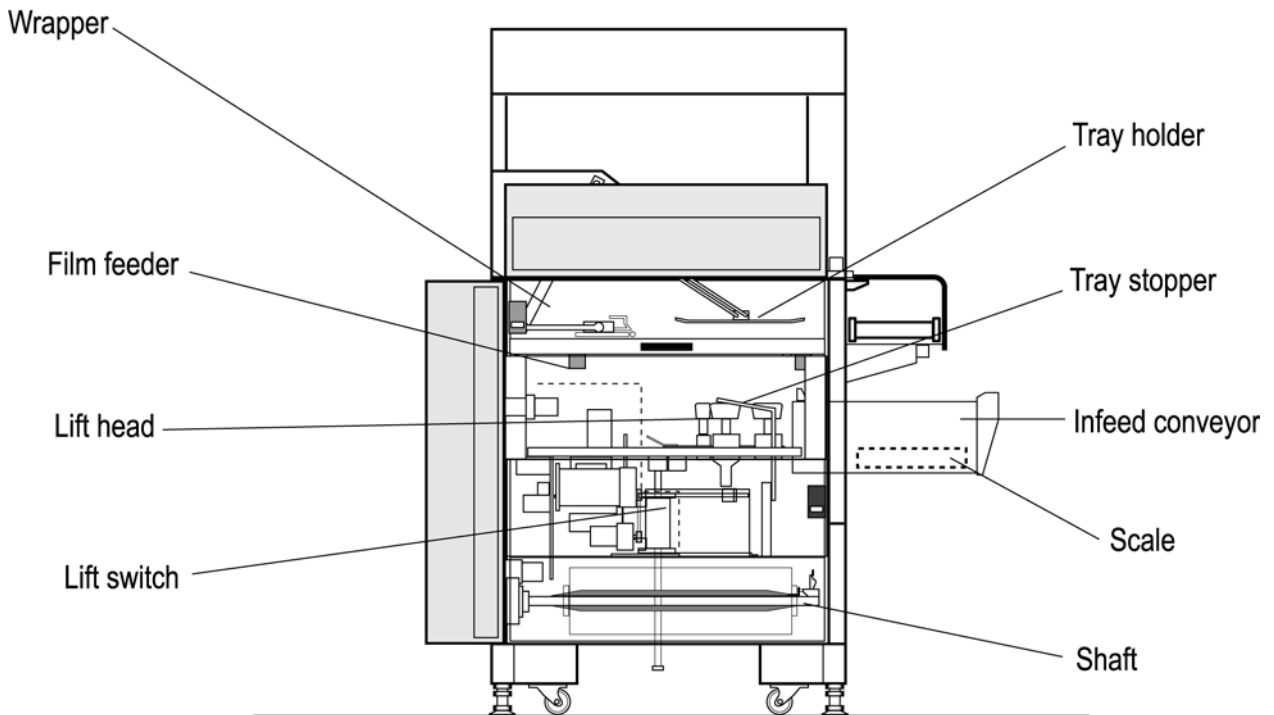

1.3 NAME OF EACH MOTOR

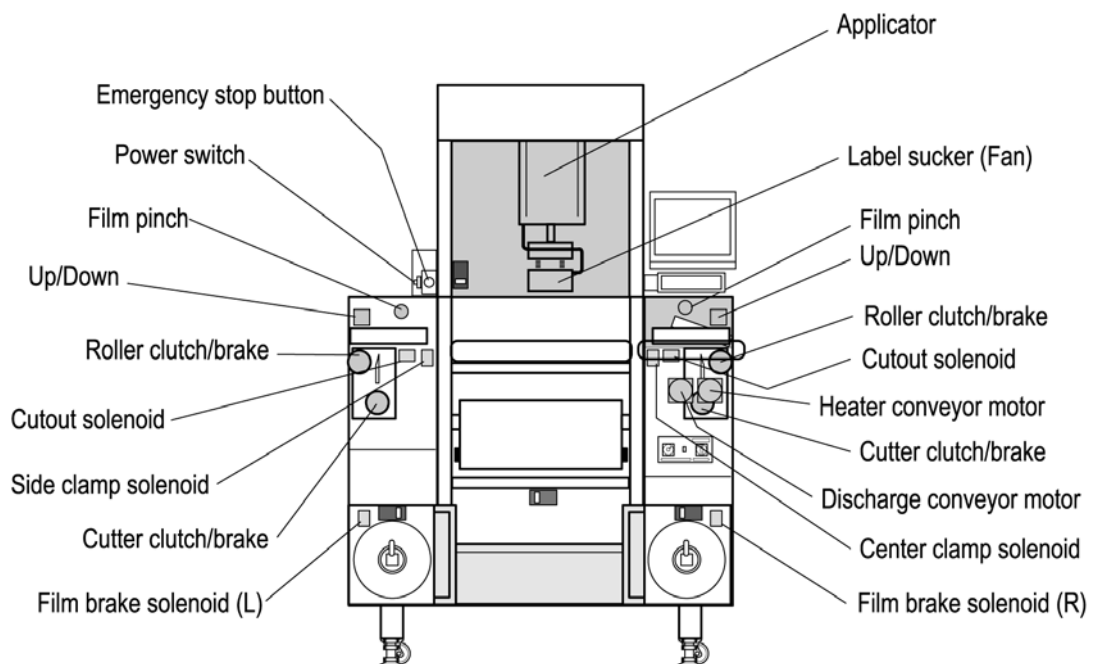
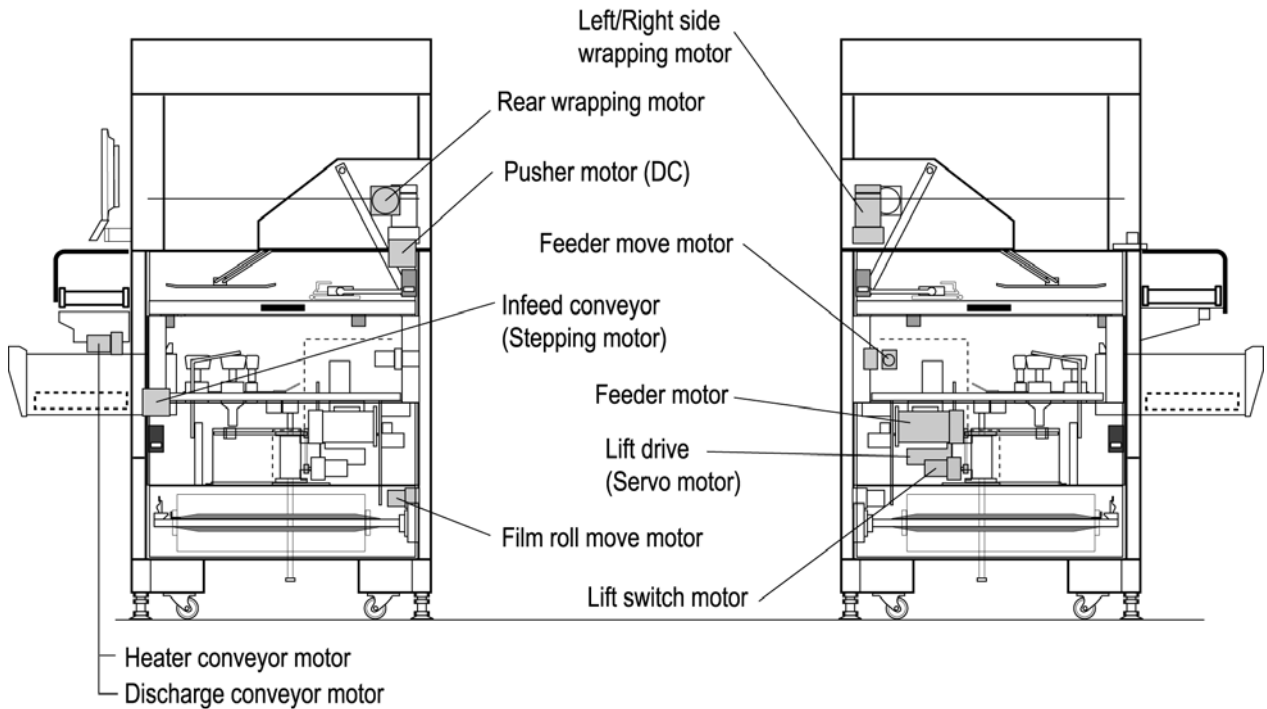

1.4 NAME OF EACH POWER SUPPLY

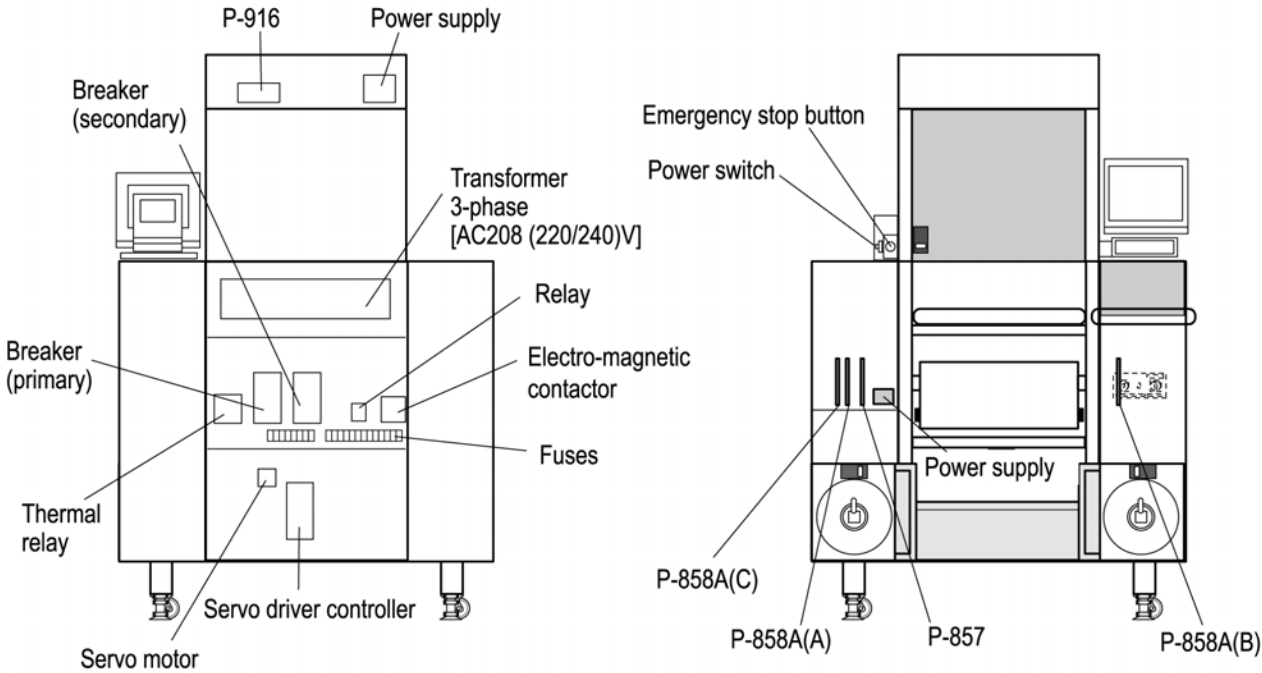
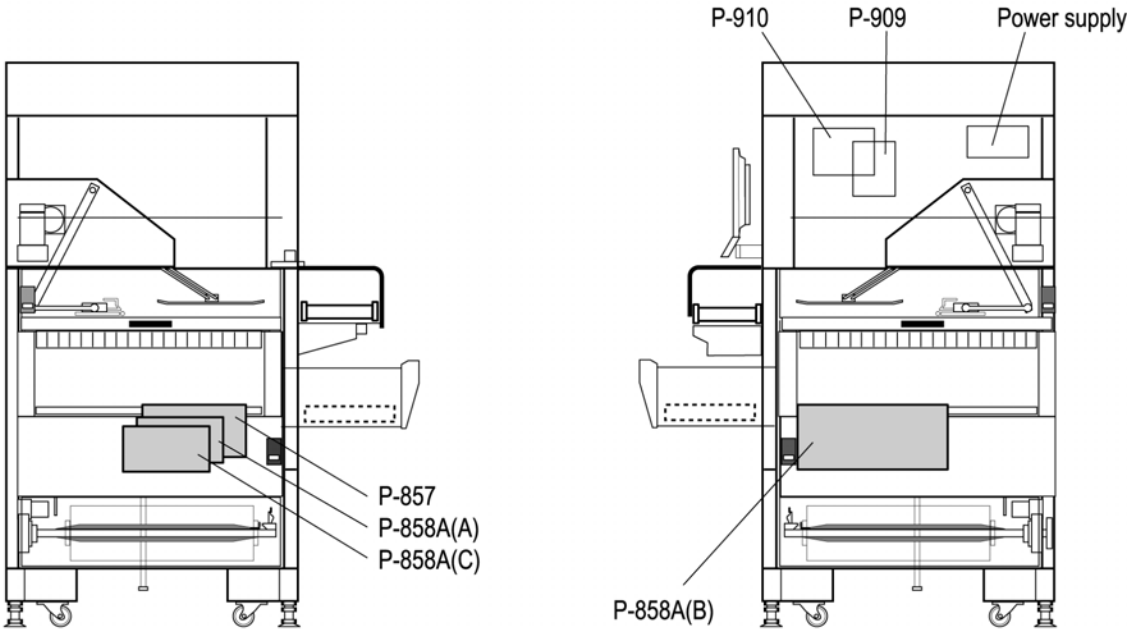

1.5 FUNCTION OF EACH UNIT

Infeed Conveyor	<ul style="list-style-type: none"> • Transports the tray to the lift heads. • Contains the scale and is driven by the stepping motor after the tray is weighed. The motor drives a chain containing four claws that push the tray. The chain stops when it passes the reference position sensor.
Scale	<ul style="list-style-type: none"> • Weighs up to 30 lbs. 0.01 lb (from 15 lbs. up to 30 lbs.).
Lift Drive	<ul style="list-style-type: none"> • Lifts the tray vertically up to the wrapper unit. • The servo controller receives the activating signal and is started by the controller. The lift drive utilizes two different movements: "Up/down for wrapping" and "Up/down for switching between large and small lifts."
Lift Head	<ul style="list-style-type: none"> • Transports trays and tilt to facilitate the wrapping action. • There are 15 heads, out of which five sliding heads are used depending on the tray size.
Rear Squeezing Plate	<ul style="list-style-type: none"> • Slides in and folds the film underneath the tray from the rear direction. • The motor starts with the start timing.
Left/Right Squeezing Plate	<ul style="list-style-type: none"> • Slides in and folds the film underneath the tray from left and right sides. • The motor starts with the wrapping start timing.
Pusher	<ul style="list-style-type: none"> • Wraps the film under the front of the tray and pushes the tray out. • The motor starts with the wrapping start timing.
Feeder Drive	<ul style="list-style-type: none"> • Drives the feed belt, feed roller, and cutter. • When the motor moves, the front and back feeders turn the number of times specified by the encoder. The feed roller and cutter switch on and off using a clutch and brake.
Feeder Mover	<ul style="list-style-type: none"> • Moves the rear feeder depending on the size of the film using a motor. • For 2 and 3 roll types, the sensors detect the width of each film and move to the film width. • For the 1 roll type, the feeder mover moves to the where the sensor detects the end of the film.
Film Feeder	<ul style="list-style-type: none"> • Feeds and grips the film during wrapping. • Feeds the film using the count photo sensor according to the programmed tray length. It also grips the film with the side and center clamps to stretch the film during wrapping.
Set Roller	<ul style="list-style-type: none"> • Sets the film into the film feeder. • To set the film, lift the set roller, place the film onto the set roller with both hands so that it sticks to the feeder belt, and close the set roller. • Film Grip: Holds the film already set onto the feed belt when on standby. • Film Up/Down: Raises the end of the film off the feed belt after it has been gripped. • Cut-off belt: Cuts the film along the perforated line. • Cuts off the film from the feeder belt and keeps it away from the belt during film centering.
Feeder Roller	<ul style="list-style-type: none"> • Joined via a clutch to the feeder drive, this roller sends the film to the feeder belt. A brake stops it.
Cutter	<ul style="list-style-type: none"> • The cutter makes a perforation in the film for the appropriate size. • The brake stops it.
Film Holder	<ul style="list-style-type: none"> • Sets the appropriate film. • In the two roll model, film can be set on the left and right hand sides. • For the 1 roll model, film can be set on the right.
Heater	<ul style="list-style-type: none"> • Seals the film underneath the tray after it is wrapped. • The heater is used at approximately 120°C. Special caution needs to be taken with the temperature setting for polyethylene films.

Printer	<ul style="list-style-type: none"> • Prints out labels (47mm -80mm (W) x 45mm-105mm (H)).
Label Applicator	<ul style="list-style-type: none"> • Holds labels using a suction plate and applies the label to trays in accordance with the applicator timing signal. The amount of arm movement can be adjusted to fit the volume in trays.
Label Applicator Mover	<ul style="list-style-type: none"> • Adjusts the label position depending on the length of the tray. • It moves left and right to the position (1 to 12) programmed for that tray.
Control Console	<ul style="list-style-type: none"> • Controlled by the P-910 board. • It has a connection to the scale, wrapper, and printer, etc. • The 10.4 inch TFT color LCD (touch panel) is used for display.
Power Supply Unit	<ul style="list-style-type: none"> • Contains the power supply and boards (P-857, P-858A, P-858B, P-858C). • P-857 : Wrapper CPU board (ROM) • P-858A : Driver board • P-858B : Driver board (mainly right hand) • P-858C : Driver board (mainly left hand) • 24V power supply • Stepping driver (ROM) • Electromagnetic Contactor : Thermal Relay
Film Roll Unit	<ul style="list-style-type: none"> • Helps film feeding actively by driving the film roll. • The film roll drive is synchronized with the feeder drive.
Discharge Conveyor	<ul style="list-style-type: none"> • A conveyor that discharges a tray discharged from the wrapper in a 90° right or right direction.
Heater Conveyor	<ul style="list-style-type: none"> • A conveyor that temporarily stops a tray ejected from the discharge conveyor wrapper, seals a film on the tray bottom, and ejects it after a given time.

1.6 WARNING SYMBOLS

1.6.1 WARNINGS and PRECAUTIONS

This machine is manufactured for use according to proper procedures by qualified service personnel and only for the purposes described in this manual.

The warning symbols in this manual and warning stickers affixed to the machine itself are divided into three categories depending on the level of danger or seriousness of potential injury. The definition for each of these warnings and precautions are shown below. Failure to heed these warnings and precautions may result in bodily injury or damage to the machine.



Indicates information that, if not heeded, is likely to result in loss of life or serious injury.



Indicates information that, if not heeded, could possibly result in loss of life or serious injury.



Indicates information that, if not heeded, could result in relatively serious or minor injury, damage to the machine, or faulty operation.

1.6.2 STICKER DEFINITIONS

Warning stickers are affixed to the machine to warn operators of possible dangers.



This sticker indicates that the main power should be disconnected when performing any type of internal maintenance or service on the machine.

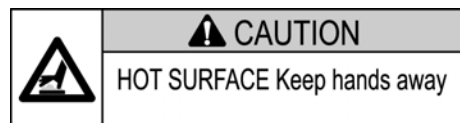

This sticker indicates that hands should be kept away from hot surfaces.



This sticker indicates that the emergency stop button should always be pressed before servicing the machine internally.

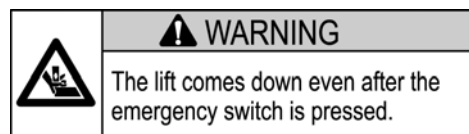

This sticker indicates that there is a danger hands may get caught when the lift comes down, even after the emergency switch has been pressed.



This sticker indicates that the maximum load at full extension should not exceed 10 lbs. on the infeed conveyor cover.



This sticker is placed on parts where there is a danger of the operator being cut by a cutting mechanism such as the cutter. Always press the emergency stop button before starting work near any cutting mechanism.



This sticker indicates that there is a danger of electric shock on the power supply unit cover.

1.7 BASIC SPECIFICATIONS

Scale	Weighing capacity (Multi-range)	30 lbs/0.01 lb
	Wrapping capacity (Single-range)	15 lbs/0.005 lb
	Accuracy	1/3000
Printer	Thermal head	76mm, 8 dots/mm
	Printing speed	100mm/sec.
	Printing size	47mm -80mm (W) x 45mm-105mm (H)
	Font style	Reverse, Bold, Reverse, Underline, Ruled Line
Control Console	Display method	10.4 inch TFT color LCD (touch panel)
	Function keys	Available
	Number of programs	Up to approx. 3000 (when production total is not performed)
Wrapper	Wrapping speed	Max. 30 packs/min. (190 x 100mm tray)
	Wrapping sizes	130 to 410mm (W) : 5.1 to 16.1 inch 130 to 260mm (D) : 5.1 to 10.2 inch 20 to 150mm (H) : 0.8 to 5.9 inch
	Film size	350 to 610mm: 13.8 to 24.0 inch
	Film material	Poly Orophine / Vinyl chloride
Power supply		3-phase 208 (220/240) VAC, 60Hz

Note 1: Wrapping conditions listed in the above specifications may differ depending on tray shape or weight.

2: Specifications are subject to change without prior notice.

2

INSTALLATION

CONTENTS

2.1	INSTALLATION PRECAUTIONS	2-2
2.2	INSTALLATION SPACE	2-6
2.3	SAFETY SWITCHES	2-7
2.4	MAIN POWER ON/OFF	2-8
2.5	LABEL SETTING	2-9
2.6	FILM LOADING METHOD	2-11
2.7	HEATER TEMPERATURE ADJUSTMENT	2-18

2.1 INSTALLATION PRECAUTIONS

2.1.1 NECESSARY TOOLS

- OMNi-4000ST Service Manual (this manual)
- Phillips head screwdriver
- Adjustable wrench (more than 30mm jaw extension)
- Open-ended wrench (30mm)
- Allen wrench key set
- Box wrench (7, 8, 10mm)
- Electrician's pliers
- Level (200 to 250mm)

*Note: Use instruments with precision greater than 2/1000.
IF-21 FD (3.5 inch floppy disk)*

2.1.2 WORK CLOTHES

- Avoid wearing loose clothing that might be caught in the machine.
- Shirt sleeves should be kept buttoned or rolled securely above the elbows.
- Do not wear gloves to keep fingers or hands from getting caught in the machine.
Ties should be tucked inside shirts.

2.1.3 PROHIBITED LOCATIONS



Do not install the machine in the following types of places:

- Places subject to high temperatures or high humidity
- Places exposed to direct sunlight
- Places where water or other liquids are easily spilled on the machine
- Places subject to excessive vibration or unstable foundations
- Places exposed to direct cold air from air conditioners or refrigerators
- Places where the floor or foundation is unstable
- Places subject to a lot of dust or dirt
- Places with large voltage fluctuations

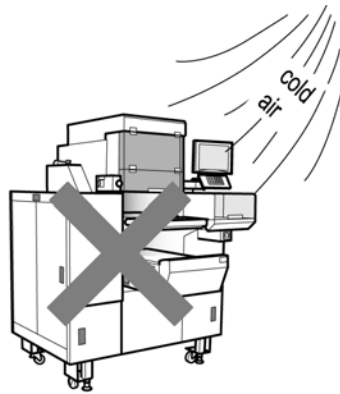
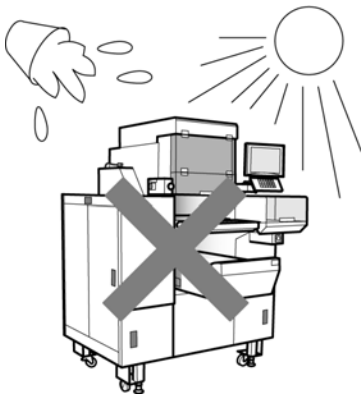

2.1.4 POWER SUPPLY

WARNING

Heed the following precautions about power supply:

- Use a power supply with rated voltage ground.
- Prepare a dedicated power source.
A power supply that generates voltage variation may cause a malfunction.
- Do not stand on the power cord, and do not place anything heavy on the cord.
Doing so may damage the cord, resulting in accident or trouble.

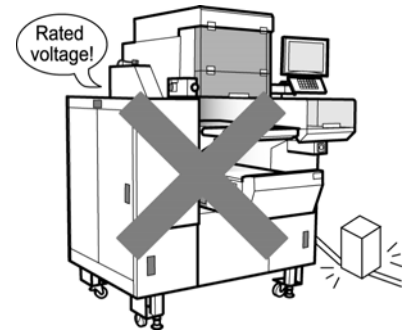

2.1.5 LEVEL ADJUSTMENT

- **Do not lift the level adjusting feet off the floor after installation.**
The machine has casters installed that may cause it to move during operation and lower wrapper speeds.
- **Always ensure that the machine is level.**
If the level is not centered, weighing will not be accurate and wrapping will not be performed well. Adjust the level adjusting feet until the bubble inside the level indicator is centered.

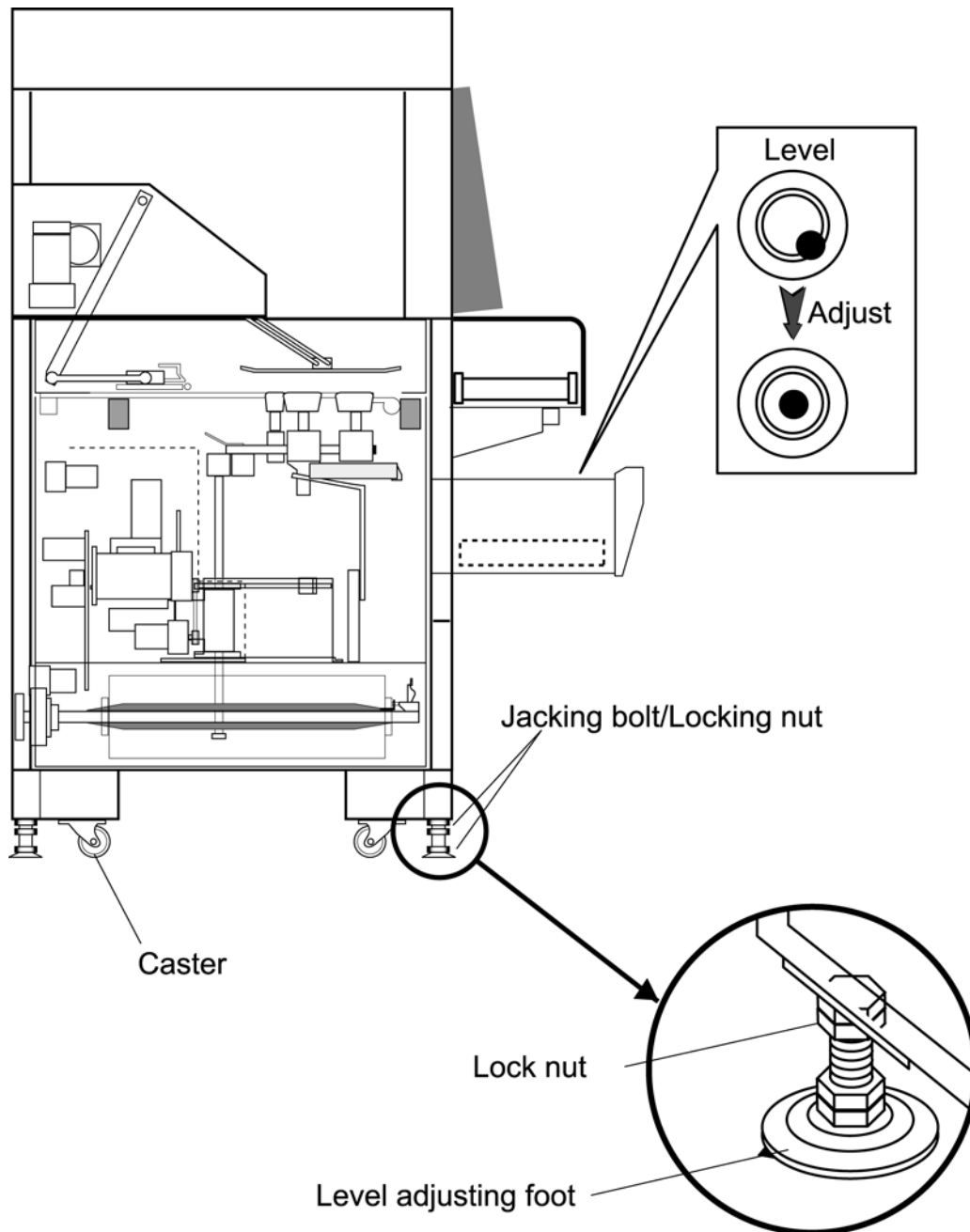

2.1.6 PACKING MATERIALS

- When transporting the machine, ensure that the packing materials located underneath the lift head are in place.

Note: If the packing materials are not in place during transportation and the machine collides with any protruding objects, this may cause the lift to fall causing damage to the rack.

- Remove the packing materials after set up is complete.

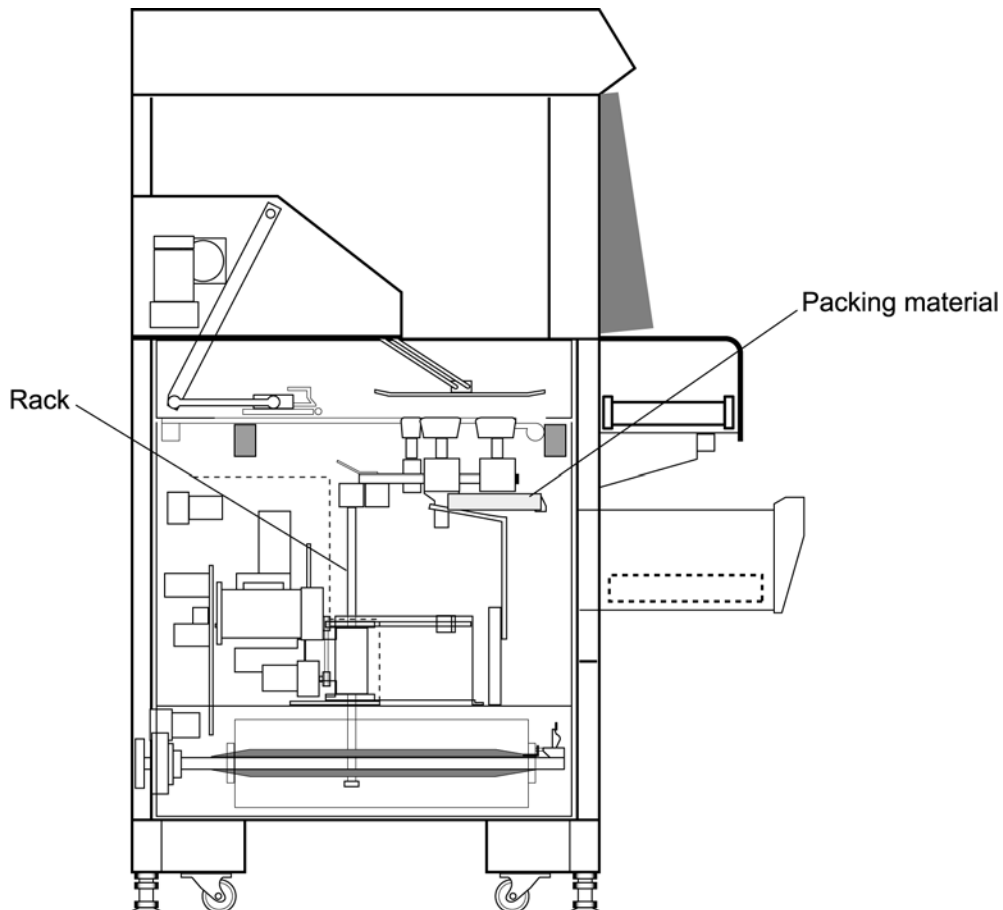

2.2 INSTALLATION SPACE

Allow ample space on either side of the machine and behind the machine to ensure easy access for maintenance.

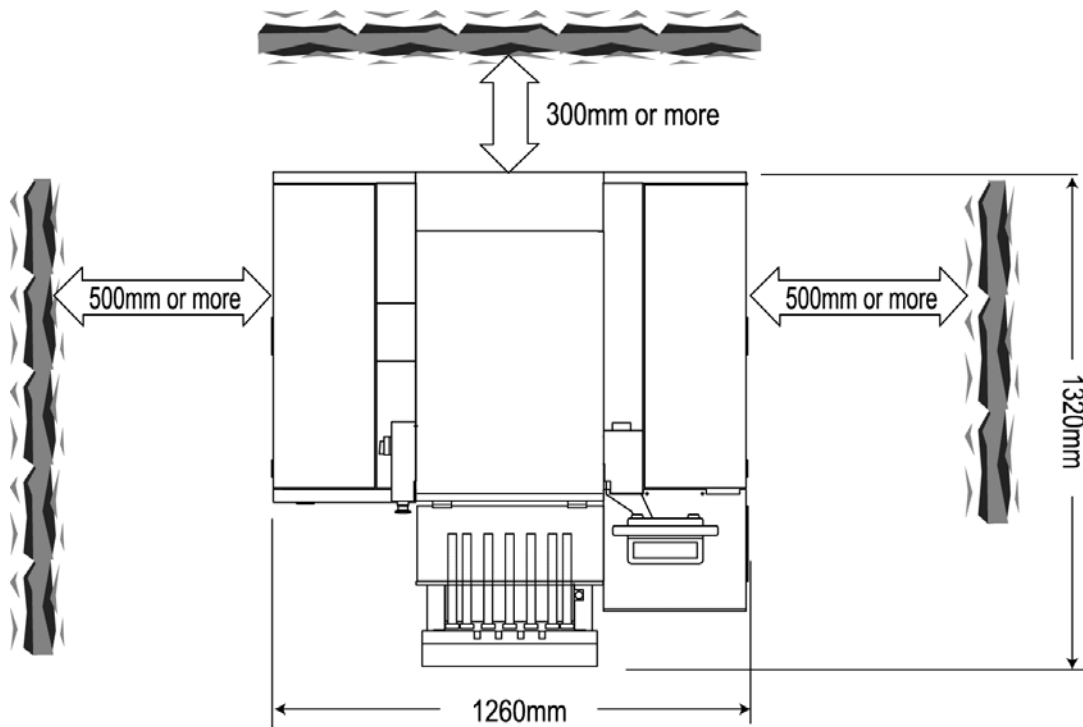

2.3 SAFETY SWITCHES

Safety switches are installed on opening doors to secure safety when cleaning the machine.

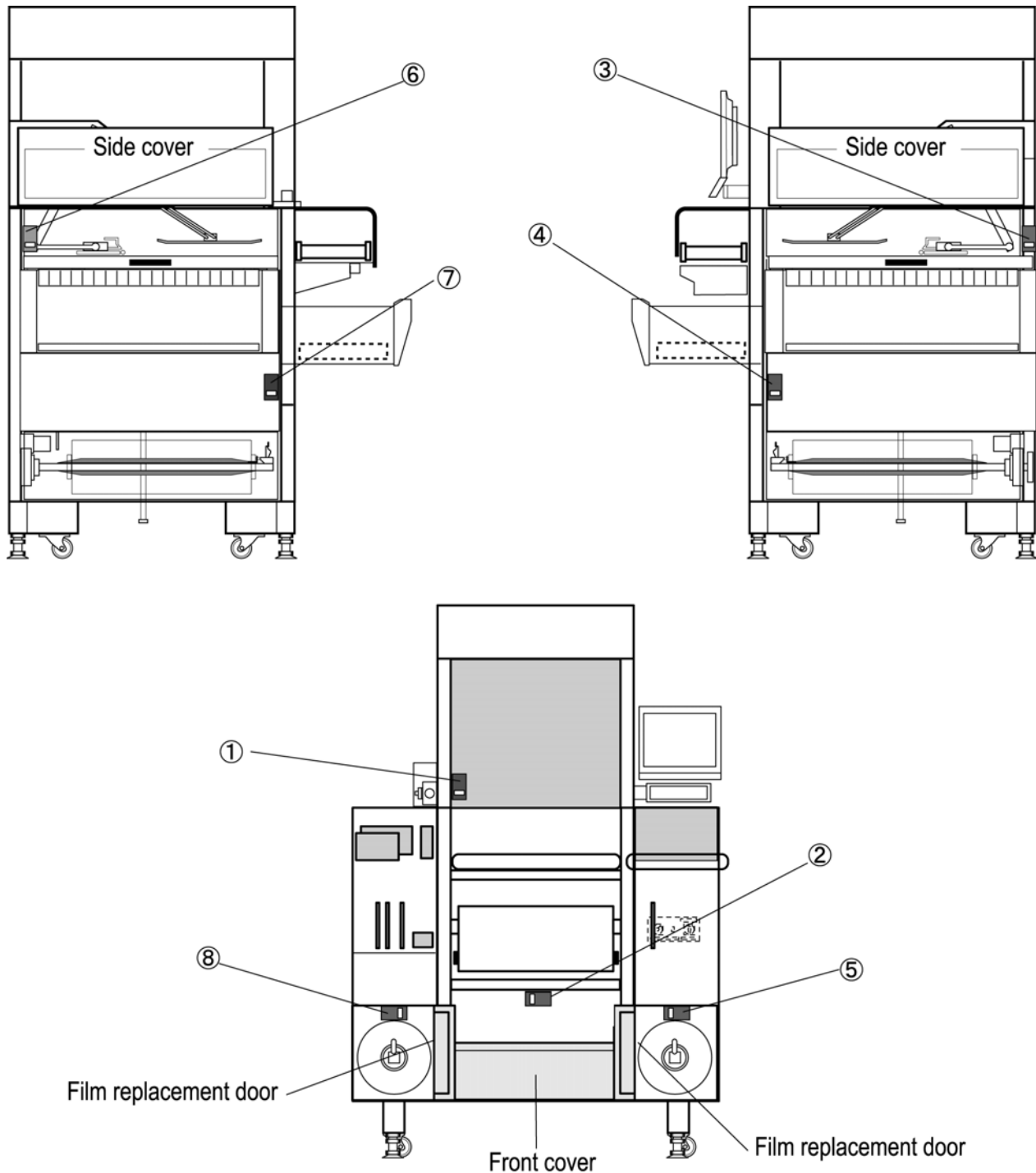

2.4 MAIN POWER ON/OFF

2.4.1 POWER ON

Turn the Main Power Switch lever clockwise.

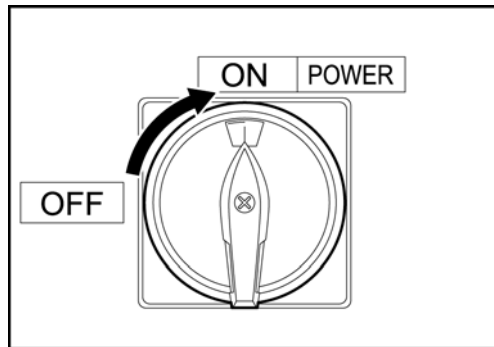

2.4.2 POWER OFF

Turn the Main Power Switch lever counter-clockwise.

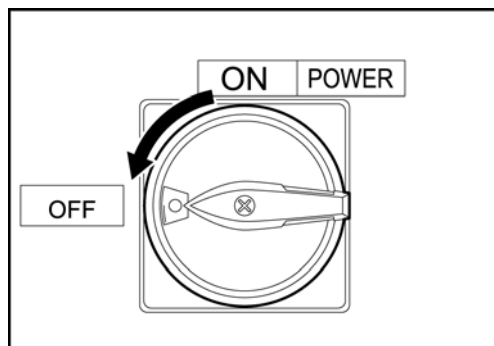

2.4.3 EMERGENCY STOP BUTTON

- Press the Emergency Stop button to stop the machine in the event of an emergency.
- Turn the button clockwise when releasing the emergency stop.



2.5 LABEL SETTING

1. Turn up the roll holding bar.

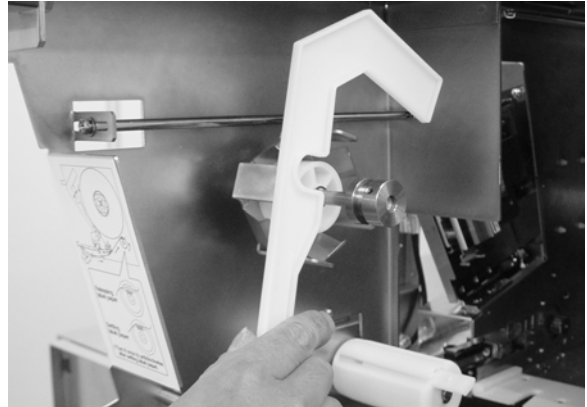

2. Insert the label roll onto the motor shaft.



3. Thread the label paper as shown below.

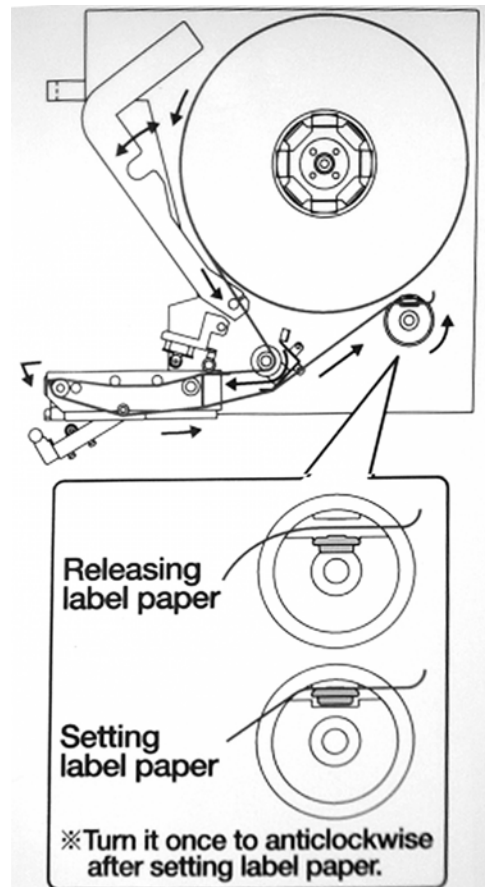

4. Turn down the roll holding bar.

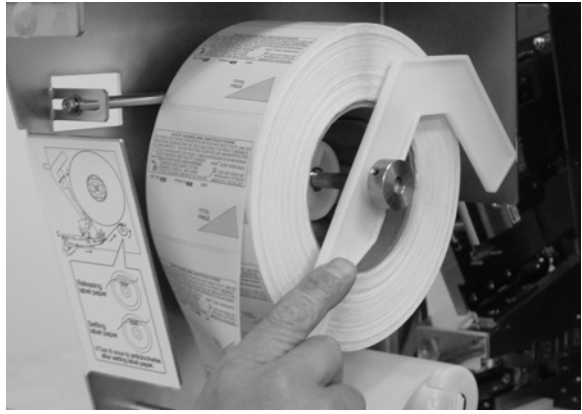

2.6 FILM LOADING METHOD

2.6.1 FILM ROLL SETTING

1. Before starting the roll setting, press the Emergency Stop button.



2. With the lever in the lowered position as shown in the figure, load the film roll onto the film holder. With pushing the end of the film core, align the near end of the film with the line on the film position decal.

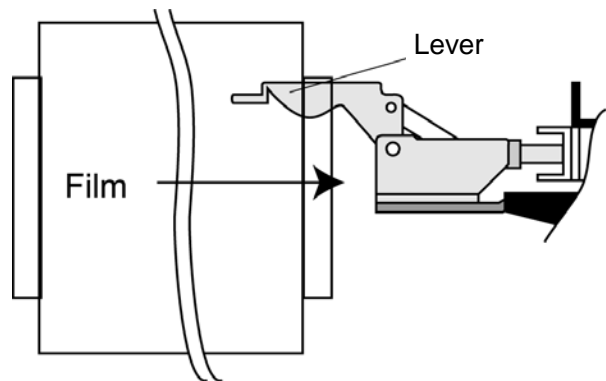

3. Raise the lever to the upright position to secure the film roll.

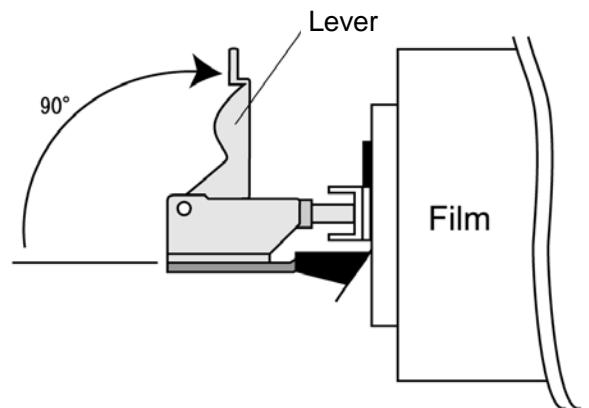

To install the Film Roll to the rear frame of the machine, attach the metal plate as shown below using the tapped screw hole on the film roll shaft.

In this case, make sure that the front side of the film roll is on the film set position bracket. When unable to fasten using the screw hole located on top of the shaft, fasten the metal plate and bracket to the shaft using the 5mm screw on the front side.

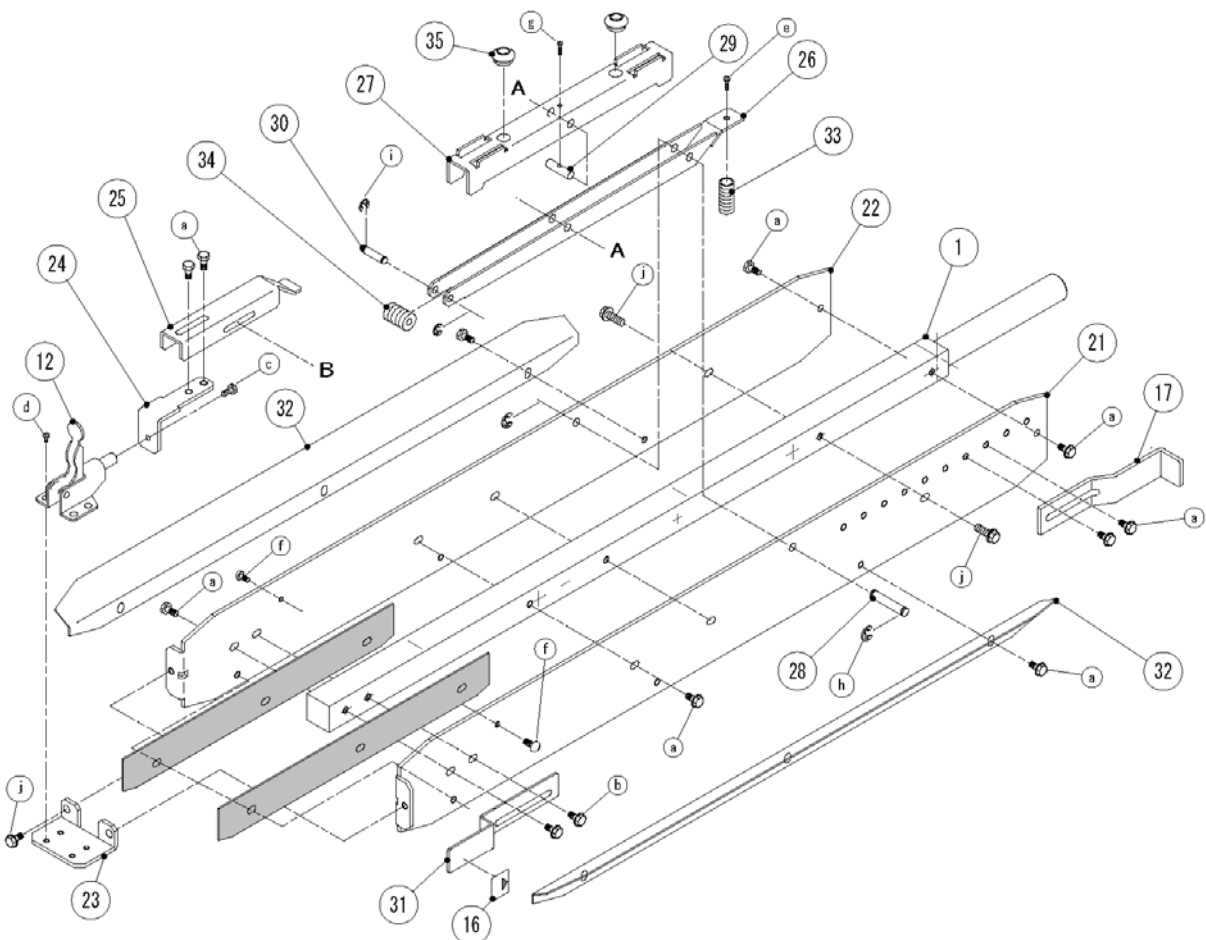
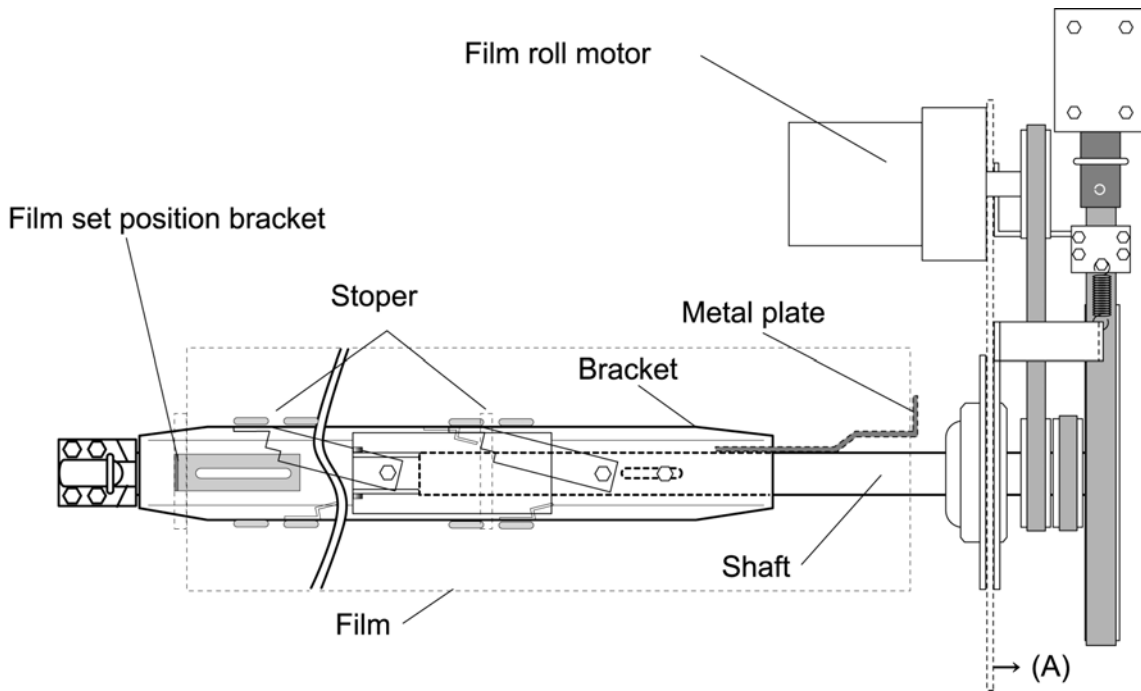

There is only one set of stoppers with this model.

If the inner roll diameter is greater than 76mm (standard value), the shaft rotation axis may be moved from the gravity center depending on the stopper position.

If the shaft stops at the position as shown in the following figure, the roll may rotate under its own gravity,

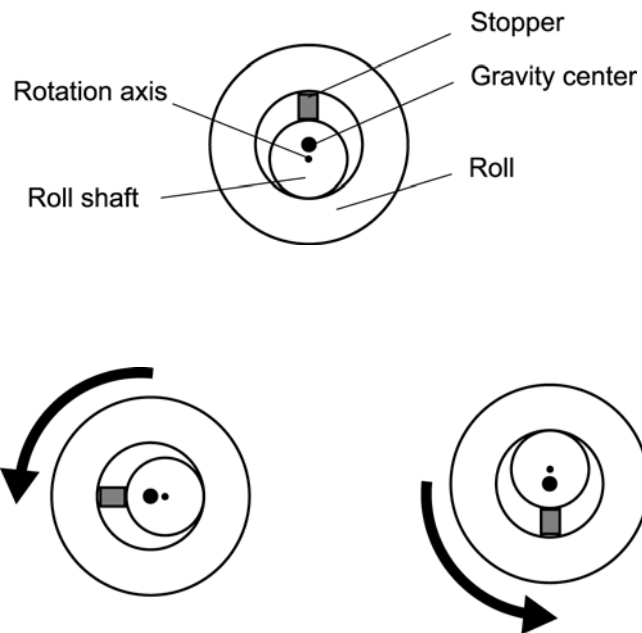

To prevent this problem, fix the attached plates as shown in Fig. A so that the rotation axis and gravity center are at the same position.

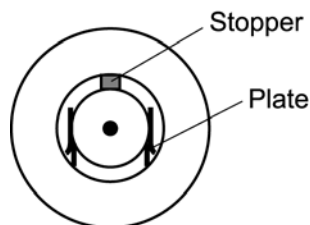

2.6.2 FILM THREADING

1. Press the Emergency Stop button.



2. Use the handle to lift up the film set roller until it locks into position.

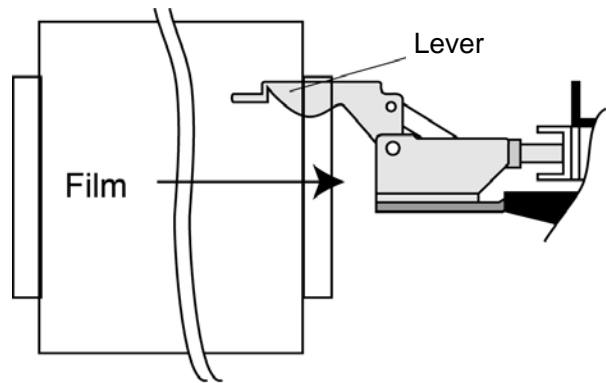

3. Thread the film as shown in the figure.

4. Evenly cut the end edge of the film, square the cut edge with the roller, then place both side edges of the film on the film advance belts.

5. Confirm that the film edge is aligned exactly with the line appearing on the roll set position decal. Adjust plate position to align film edge.

6. Lift up the handle with one hand, remove the pin with the other, then close the film set roller.

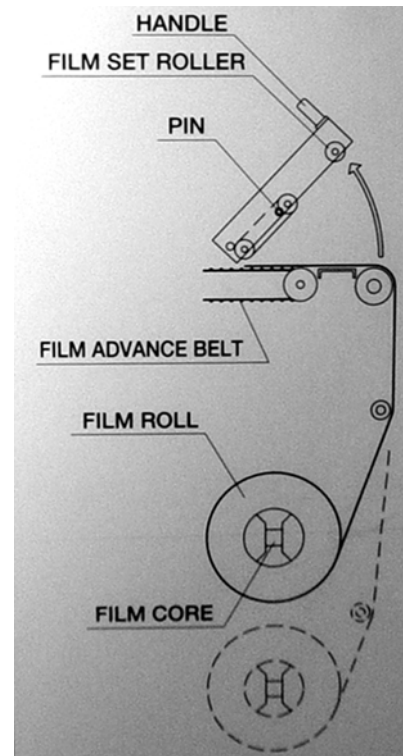

7. Release the Emergency Stop button then press the Film Set button.



-
8. When film is advanced normally, close the film set unit door, press the Emergency Stop button, and remove the film.

Note: Unless the Emergency Stop button has been pressed, the film cannot be removed because it is pinched by the clamp.

-
9. Release the Emergency Stop button.
-

2.6.3 FILM WIDTH ADJUSTMENT

1. After setting the film, press the [Film Set] button and feed a few pieces of film.
2. Make sure that both edges of the film are placed on each end (A) of the Film Feeder Belt. They can exceed the end (A) by 5mm at maximum.
3. At the same time, check that the film on the rear feeder belt is properly aligned. If the film comes over, loosen the Film Size Sensor wing bold and move the sensor bracket to the required position. Press the [Film Set] button in order to adjust the rear feeder position at the Film Size Sensor, and feed a few pieces of film to confirm the position.

Note: The amount of film over wrapping should be same for the front and rear sides.

After completion of the film position adjustment, be sure to fix the metal plate and film set position bracket at the edge of paper film roll.

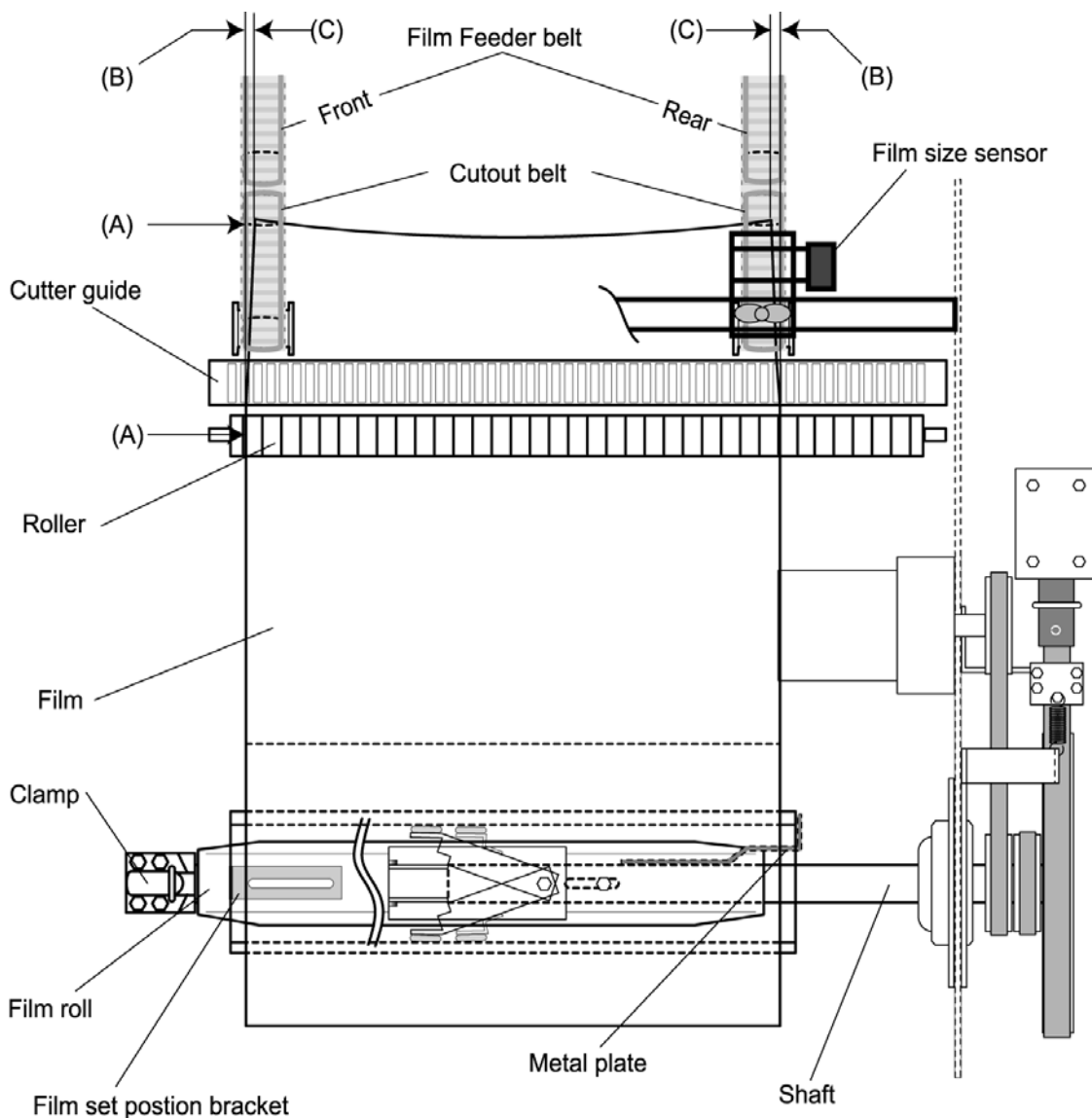

2.6.4 BRAKE UNIT ADJUSTMENT

The brake unit stops rotation of the film roll when film feeding stops. The brake will activate by the energized solenoid when film feed is stopped and stop the rotation movement. However, it can happen that the film over-runs by inertia. In this case, Adjust the solenoid position by loosening the two M5 bolts and moving the solenoid core back and forth manually to make 3-5mm clearance (A).

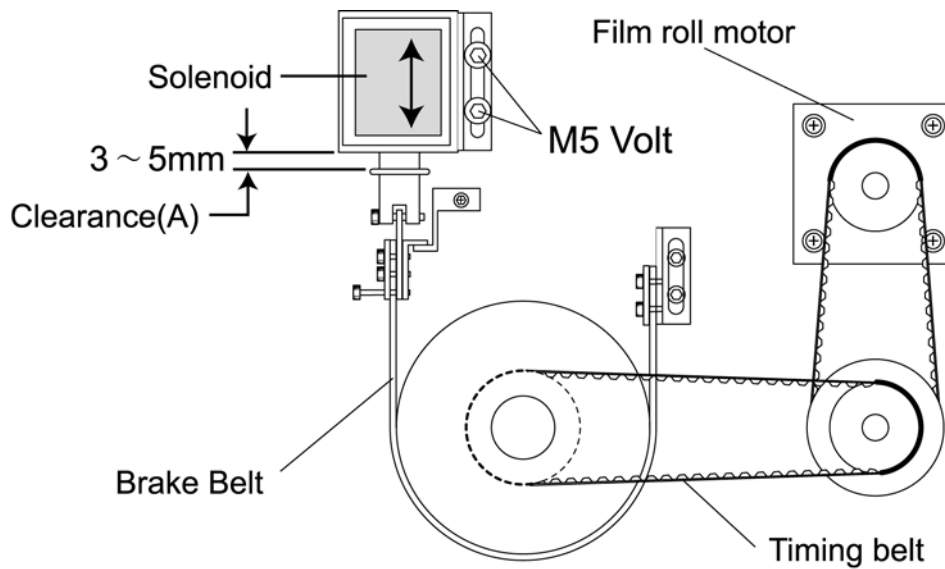

2.7 HEATER TEMPERATURE ADJUSTMENT

Set the temperature to approx. 120° to 130°C.



3

TEST MODE**CONTENTS**

3.1	STARTING PROCEDURE	3-2
3.2	TEST MENU	3-4
3.3	KEY CHECK MENU	3-6
3.4	MACHINE SETTING	3-9
3.5	SELF DIAGNOSTIC	3-12
3.6	MEMORY INITIALIZATION	3-13
3.7	DISPLAY CHECK	3-14
3.8	SCALE CALIBRATION	3-15
3.9	PRINT ADJUSTMENT	3-19
3.10	ROM VERSION DISPLAY	3-25
3.11	COMMUNICATION CHECK	3-26
3.12	OPTION CHECK	3-27
3.13	MEMORY DATA CHANGE	3-28
3.14	TIME AND DATE SETTING	3-31
3.15	PROGRAM DOWNLOADING.....	3-32
3.16	WRAPPER / APPLICATOR ADJUSTMENT	3-34
3.17	WRAPPER SETUP	3-36
3.18	APPLICATOR ADJUSTMENT	3-38

3.1 STARTING PROCEDURE

1. Turn the Main Power Switch lever clockwise to power ON the machine.

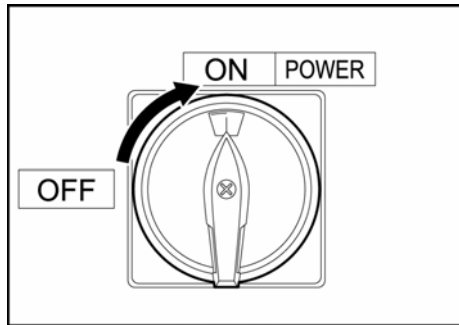

2. The Check of Return Operation screen appears. Press the [RETURN] button. The applicator moves to search the origin point and stops at the set value. The lift moves to search the lower limit sensor and stops at the origin point. The infeed chain operate one cycle

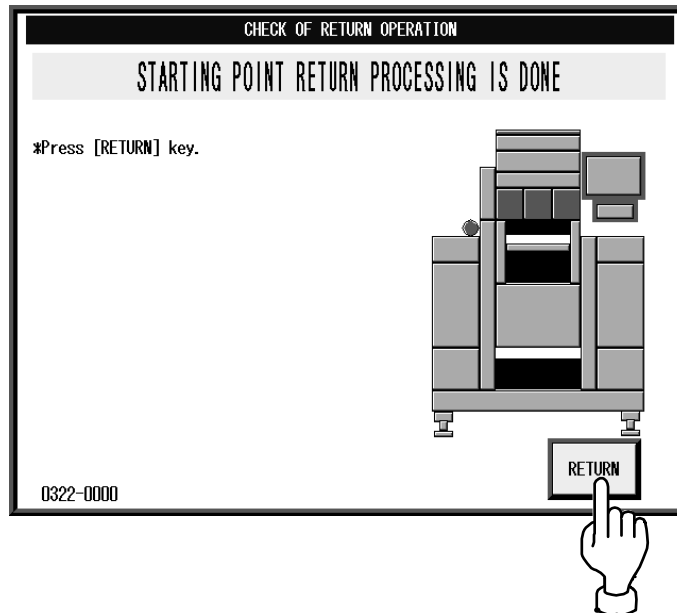

3. The initial screen appears. Press the [MENU] button on the screen.

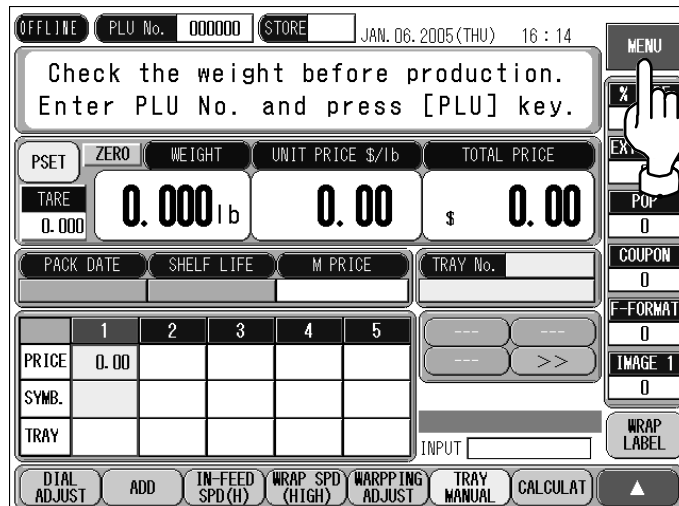

4. Enter "495344" using the numeric keys and press the [TEST MODE] button.

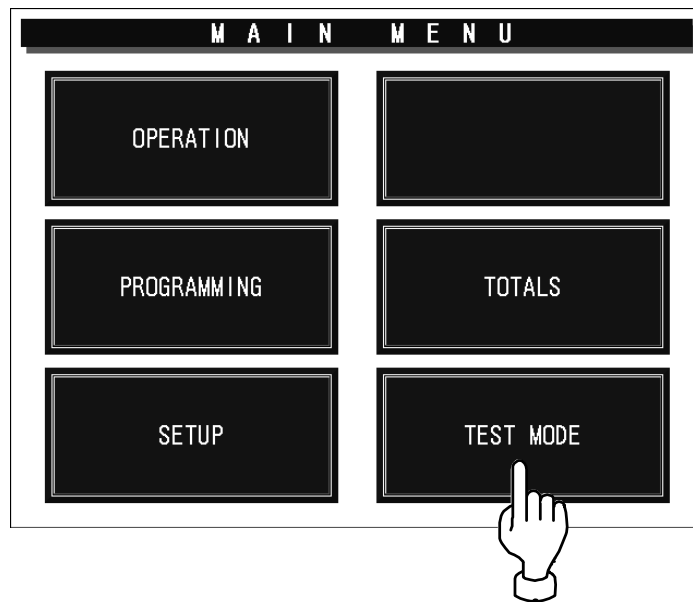

5. The Test Menu screen appears.

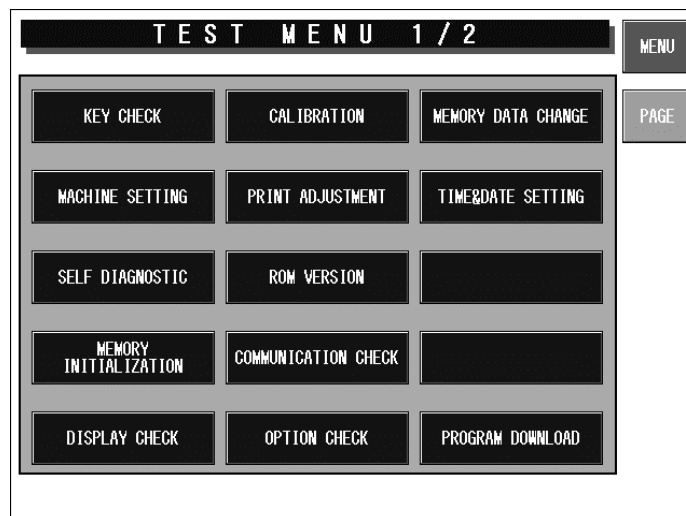

3.2 TEST MENU

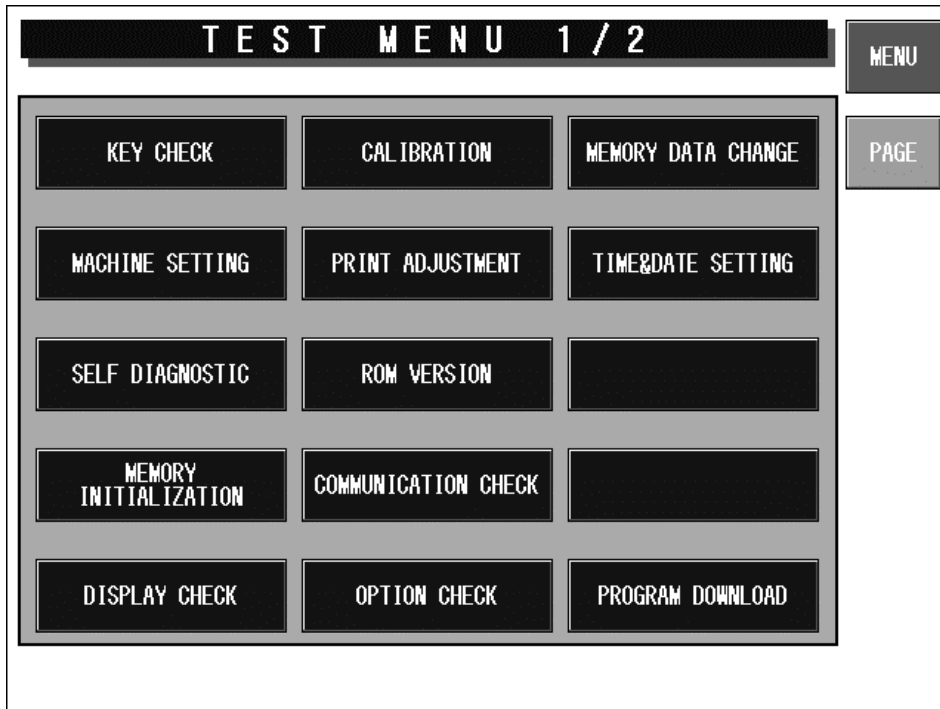

Test Menu 1/2 Screen

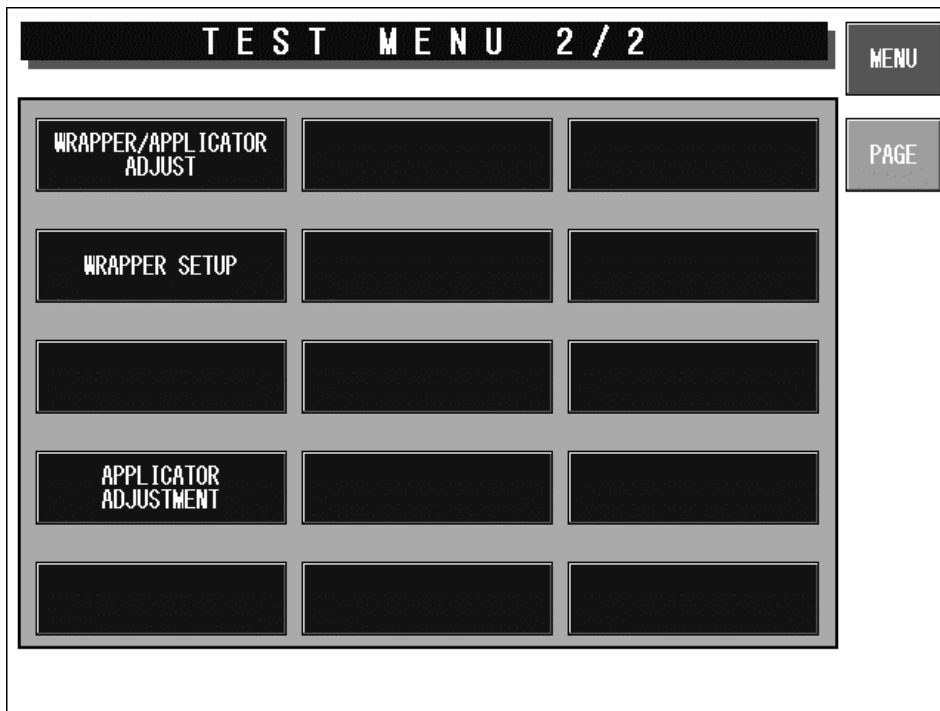

Test Menu 2/2 Screen

Buttons/Display Fields	Function
Key Check	Changes to the Key Check menu screen.
Machine Setting	Changes to the Machine Setting screen. Set basic machine and optional unit configuration.
Self-Diagnostic	Changes to the Self-diagnostic screen. Check cables, memory, printer head and connection check, etc.
Memory Initialization	Changes to the Memory Initialization screen. Display memory information (installed and remainder) and initialize memory (master data clear, system data initialization, and test data setting).
Display Check	Changes to the Display Check screen. Adjust color contrast.
Calibration	Changes to the Scale Calibration screen. There are two screens for calibrating the scale and setting the scale board. (Scale board setting requires password entry)
Print Adjustment	There are two screens for adjusting the printer head information (head type, head resistance, head running distance, etc.) and the print information (print density, various sensor distances, label length, etc.).
ROM Version	Changes to ROM Version screen. Displays ROM versions such as OS, BSP, BIOS, Main memory, Scale, ELAN, Thermal head, and Wrapper.
Communication Check	Changes to the Communication Check screen. Check I2NET and RS232C hardware (Communication and RAM).
Option Check	Changes to the Option Check screen. Check barcode scanner reading and card slot operation.
Memory Data Change	Changes to the Memory Data Change menu screen. Confirm and change SRAM memory and refer FROM.
Time/Date Setting	Changes to Date and Time Setup screen. Set the present date, time, and printing year.
Program Download	Changes to the Option Program Download screen. Download option device (wrapper, applicator, and detector) programs.
Wrapper/Applicator Adjust	Changes to the Wrapper Check screen. Perform a series of operation checks on the wrapper and applicator.
Wrapper Setup	Changes to the Wrapper Setting screen. Initialize and set data stored in the wrapper.
Applicator Adjustment	Changes to the Applicator Adjustment screen. Execute applicator calibration.

3.3 KEY CHECK MENU

Press the [Key Check] button on the Test Menu screen. Then, the Key Check Menu screen appears.

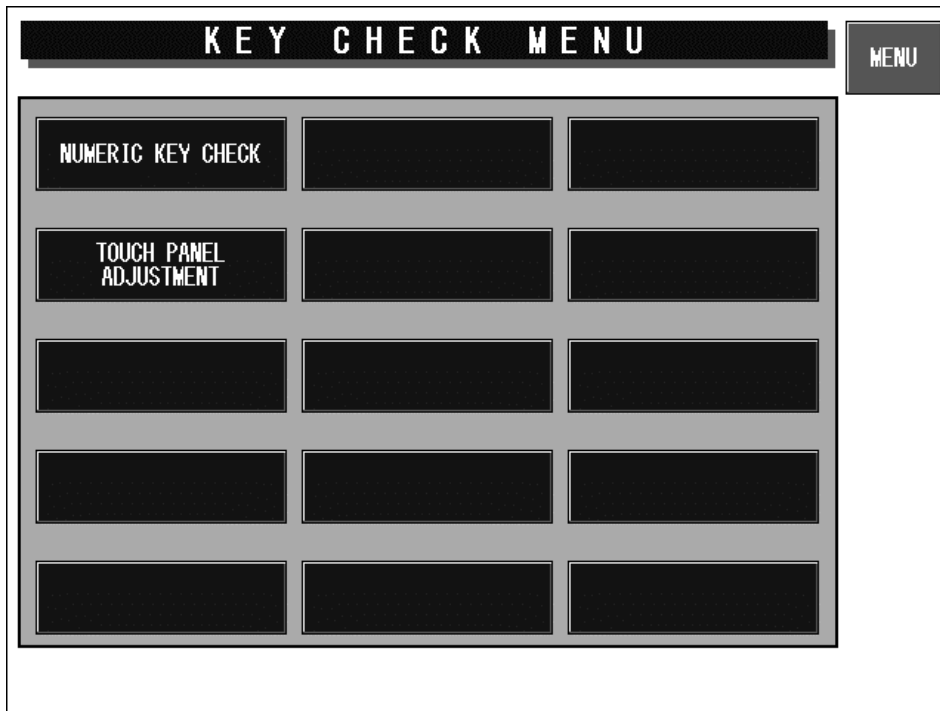

Key Check Menu Screen

Buttons/Display Fields	Function
MENU	Returns to the Test Menu 1/2 screen.
Numeric Key Check	Changes to the Numeric Key Check screen. Press the stroke keys on the keypad, then the corresponding button will change its color black on the screen.
Touch Panel Adjustment	Changes to the Touch Panel Adjustment screen. Adjust touch panel press position by pressing the center marks (+) on the two buttons located at the top left and the bottom right of the screen using a pointed object, and finally pressing the center mark (+) on the acknowledge button.

3.3.1 STROKE KEY CHECK

Press the [Numeric Key Check] button on the Key Check Menu screen. Then, the Numeric Key Check screen appears. Stroke keys can be tested by pressing each key on the control console. Pressing each numeric key will temporarily change the corresponding button color to black. After checking all stroke keys, press the [MENU] button to return to the Key Check Menu screen.

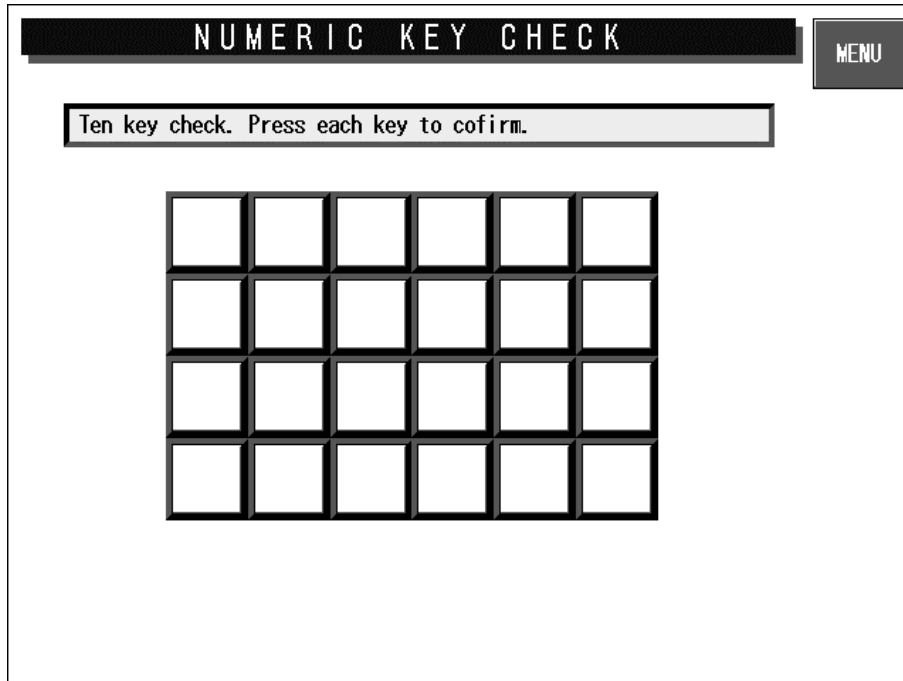

Numeric Key Check Screen

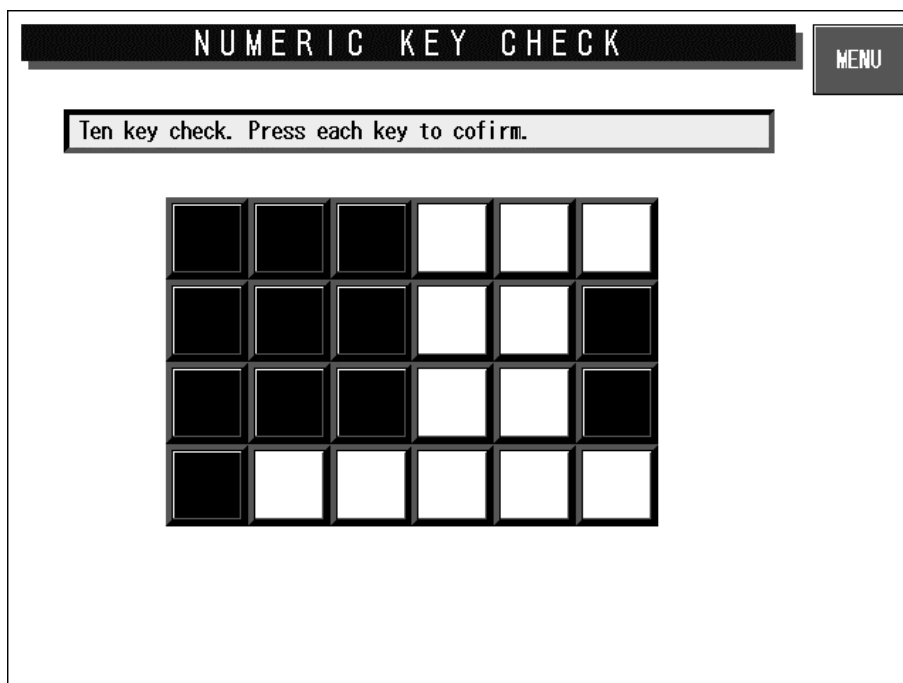

Confirmation Screen

Buttons/Display Fields	Function
MENU	Returns to the Key Check Menu screen.

3.3.2 TOUCH PANEL ADJUSTMENT

Press the [Touch Panel Adjustment] button on the Key Check Menu screen. Then, the Touch Panel Adjustment screen appears. Screen and touch panel positions on the LCD screen can be adjusted on this screen.

Press the two center marks on each button located at the top left and the bottom right of the screen using a pointed object. The pressed button will change its color to black, and the coordinates positional data of the pressed point is displayed.

In the same way, press the center mark on the Acknowledge button to complete the position adjustment.

Press the MENU button to return to the Key Check Menu screen.

Note 1: Be sure to adjust the touch panel after system data has been initialized.

Note 2: To access the touch panel adjustment screen, press the keys in the order of [PRINT], [TARE], and [PLU] on the control console while the Main Menu screen is displayed.

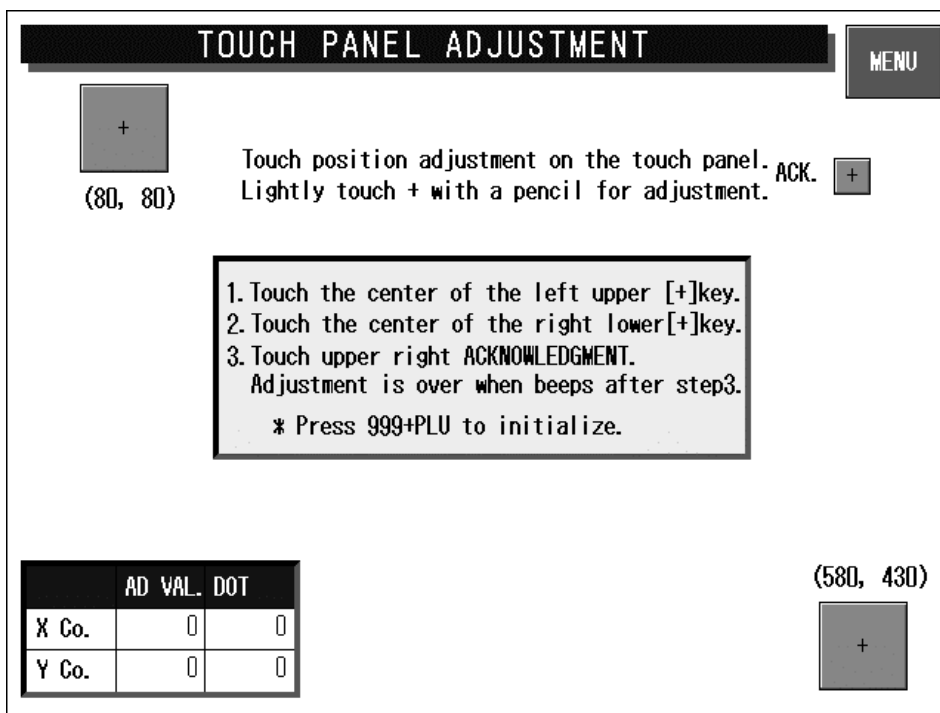

Touch Panel Adjustment Screen

Buttons/Display Fields	Function
MENU	Changes to the Key Check Menu screen.
Position Adjustment [+]	Press only the “+” mark on the buttons located at the top left and the bottom right of the screen. Pressing these buttons will change the button color to black.
Acknowledge [+]	Completes position adjustment.
Coordinate Display Field	Displays coordinate information.

3.4 MACHINE SETTING

Press the [Machine Setting] button on the Test Menu screen. Then, the Machine Set 1/2 (Component) screen appears.

3.4.1 MACHINE SET 1/2 (COMPONENT)

This procedure is used to determine which program is to be used with this machine. Press one of the buttons based on the actual machine configuration. When selected, the button color will reverse yellow.

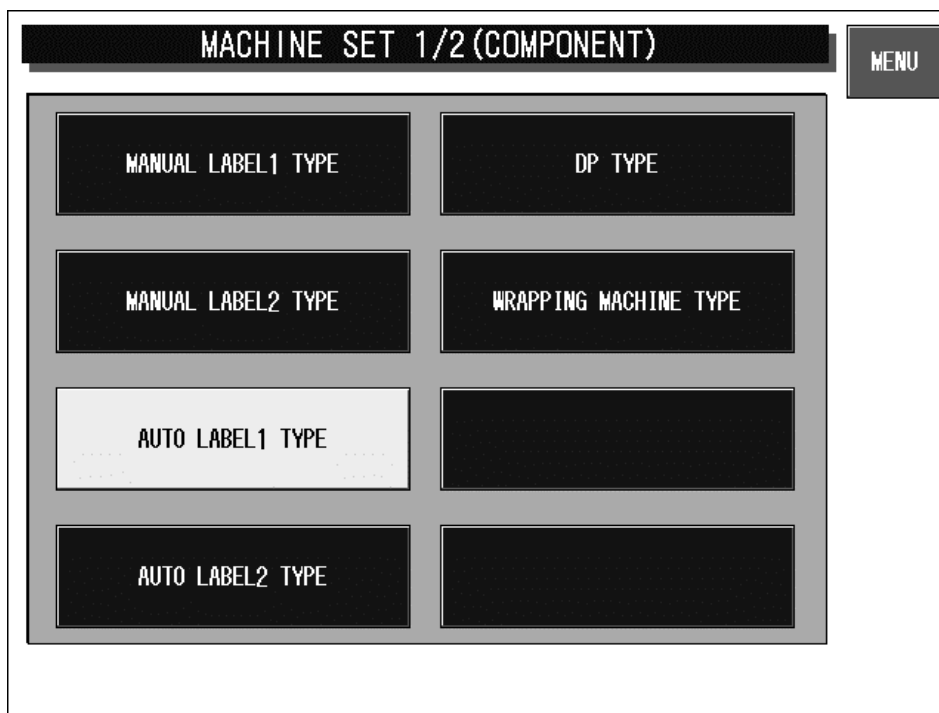

Machine Set 1/2 (Component) Screen

Buttons/Display field	Function
MENU	Changes to the Test Menu 1/2 screen.
Manual Label 1 Type	Used when no applicator is provided, and only one printer is equipped.
Manual Label 2 Type	Used when no applicator is provided, and two printers are equipped.
Auto Label 1 Type	Used when the applicator is provided, and only one printer is equipped.
Auto Label 2 Type	Used when the applicator is provided, and two printers are equipped.
DP Type	Used when no wrapping unit is equipped.
Wrapping Machine Type	Used when the wrapping unit is equipped only.

3.4.2 MACHINE SET 2/2 (VARIATION)

On this screen, further detailed settings can be performed.

MACHINE SETTING 2/2 (VARIATION)						MENU
CONFIGURATION		AUTO LABEL1 TYPE				
WRAPPER SETUP ITEM	COMM. with wrapper is normal. Proceed setting.					
	NONE		YES			
	NONE	YES	There is no Film.	NONE	YES	
FILM SWITCH SYSTEM	1 FILM	2 FILM		NONE	YES	
VARIATION	STOCK TYPE (J TYPE)					
DISCHARGE DIRECTION	LEFT		RIGHT			
PRINTER SETUP ITEM	COMM. STATUS [PRN 1:NORMAL] [APPL. :NORMAL]					
PRINTER No. 1 (NORMAL)			STANDARD	2 COLORS		
Set isn't necessary			STANDARD	2 COLORS		
Communication with printer is normal.						
ITEM HIGHLIGHTED IN RED:Communication error occurred. Check connection.						
SETUP	<- Data setting. Return to machine setting 1/2. CANCEL->				CANCEL	
CAUTION! Proceed setting, otherwise data is not effective.						

Machine Setting 2/2 (Variation) Screen

Buttons/Display Fields	Function
MENU	Returns to Test Menu 1/2 screen.
SETUP	Displays confirmation dialog screen. Press the [EXECUTE] button to register the set contents. Simultaneously executes a connection check for all connected equipment based on settings (Connection check will not be executed when an item is set).
CANCEL	Cancels changes and returns to Machine Set 1/2 screen.
Wrapper Setup Item	Displays wrapper connection results.
Tray Detect	Selects tray detection connection settings. Press "None" or "Yes" to select. The selected button will change to blue.
Centering System	Selects the centering mechanism. Press "None" or "Yes" to select. The selected button will change to blue
There is no Film.	Selects film presence error detection. Press "None" or "Yes" to select. The selected button will change to blue.
Film Switch System	Selects one or two film rolls. "1 Film": One film roll "2 Film": Two film rolls The selected button will change to blue.
PM-EMZ	Selects whether or not to use the automatic supply device.

Buttons/Display Fields	Function
Variation	Selects the machine variation. <i>Note: IF the variation is mistakenly set, the machine does not operate normally because the hard composition of the wrapping machine is different from the variation.</i>
Discharge Direction	Selects pack discharge direction. "Left": Discharge left "Right": Discharge right The selected button will change to blue.
Printer Setup Item	Displays connection results with various printers and the applicator.
Printer No.1	Selects printer #1. Press the "Standard" or "2 colors" button to select. Default data: "Standard"
Printer No.2	Select printer #2. Press the "Standard" or "2 colors" button to select. Default data: "Standard"

MACHINE SETTING 2/2 (VARIATION) MENU

CONFIGURATION

WRAPPER SETUP ITEM COMM. with wrapper is normal. Proceed setting.
 NONE YES
 NONE YES There is no Film. NONE YES

FILM SWITCH SYSTEM 1. FILM 2. FILM NONE YES

VARIATION STOCK TYPE (J TYPE)

DISCHARGE DIRECTION LEFT RIGHT

PRINTER SETUP ITEM COMM. STATUS [PRN 1:NORMAL] Proceed setting.
 PRINTER No. 1 (NORMAL) STANDARD 2 COLORS
 Set isn't necessary STANDARD 2 COLORS
 Set isn't necessary

ITEM HIGHLIGHTED IN RED:Communication error occurred. Check connection.
 <- Data setting. Return to machine setting 1/2. CANCEL->
 CAUTION! Proceed setting, otherwise data is not effective. CANCEL

MACHINE SETTING 2/2 (VARIATION) MENU

CONFIGURATION

WRAPPER SETUP ITEM Set isn't necessary
 Set isn't necessary NONE YES
 Set isn't necessary NONE YES Set isn't necessary NONE YES
 Set isn't necessary 1. FILM 2. FILM Set isn't necessary NONE YES
 Set isn't necessary STOCK TYPE (J TYPE)
 Set isn't necessary LEFT RIGHT

PRINTER SETUP ITEM Setting of this item is not necessary
 PRINTER No. 1 (NORMAL) STANDARD 2 COLORS
 Set isn't necessary STANDARD 2 COLORS
 Set isn't necessary

ITEM HIGHLIGHTED IN RED:Communication error occurred. Check connection.
 <- Data setting. Return to machine setting 1/2. CANCEL->
 CAUTION! Proceed setting, otherwise data is not effective. CANCEL

MACHINE SETTING 2/2 (VARIATION) MENU

CONFIGURATION

WRAPPER SETUP ITEM COMM. with wrapper is normal. Proceed setting.
 NONE YES
 NONE YES There is no Film. NONE YES

FILM SWITCH SYSTEM 1. FILM 2. FILM NONE YES

VARIATION STOCK TYPE (J TYPE)

DISCHARGE DIRECTION LEFT RIGHT

PRINTER SETUP ITEM Setting of this item is not necessary
 Set isn't necessary STANDARD 2 COLORS
 Set isn't necessary STANDARD 2 COLORS
 Set isn't necessary

ITEM HIGHLIGHTED IN RED:Communication error occurred. Check connection.
 <- Data setting. Return to machine setting 1/2. CANCEL->
 CAUTION! Proceed setting, otherwise data is not effective. CANCEL

3.5 SELF DIAGNOSTIC

Press the [Self Diagnostic] button on the Test Menu screen. Then, the Self Diagnostic screen appears. This procedure is used to perform self-diagnosis for the listed items. Make sure that the I2Net connectors, RS232C connectors, and card slot are provided.

Note: All memory will be initialized after executing this procedure.

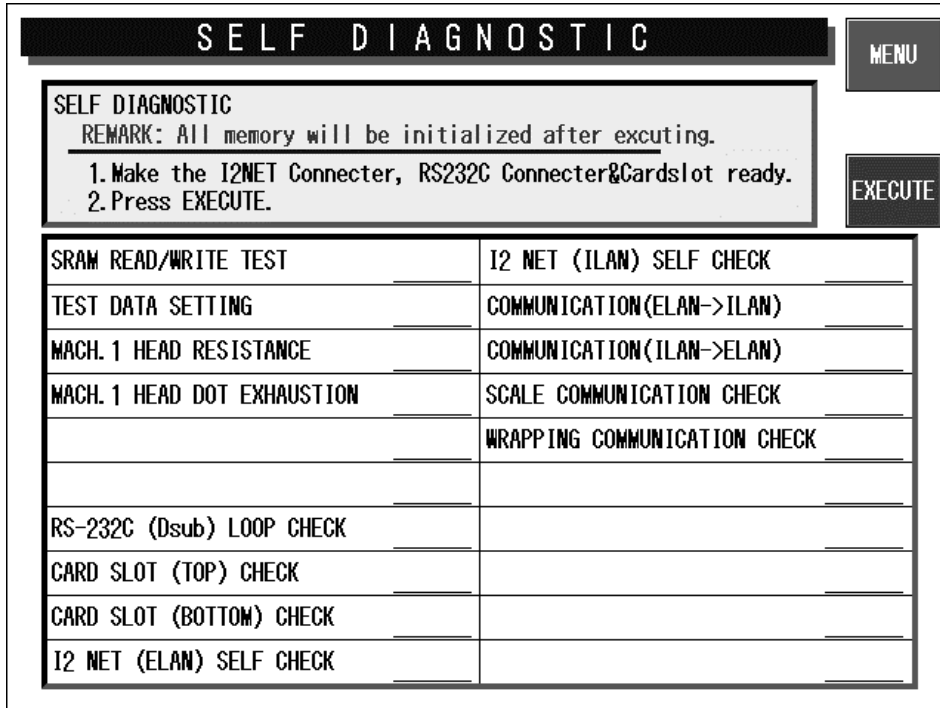

Self-diagnostic Screen

Buttons/Display Fields	Function
MENU	Returns to the Test Menu 1/2 screen.
EXECUTE	Press the [EXECUTE] button to execute cable, memory, printer head, display operation checks, and initialization.
Execution Item	Displays execution results (Operating/Normal/Abnormal) to the right of each item.

3.6 MEMORY INITIALIZATION

Press the [Memory Initialization] button on the Test Menu screen. Then, the Memory Initialization screen appears.

This procedure is used to delete all data except system data, initialize system data only, and create test data.

Note: Repeat the procedure if memory initialization ends abnormally.

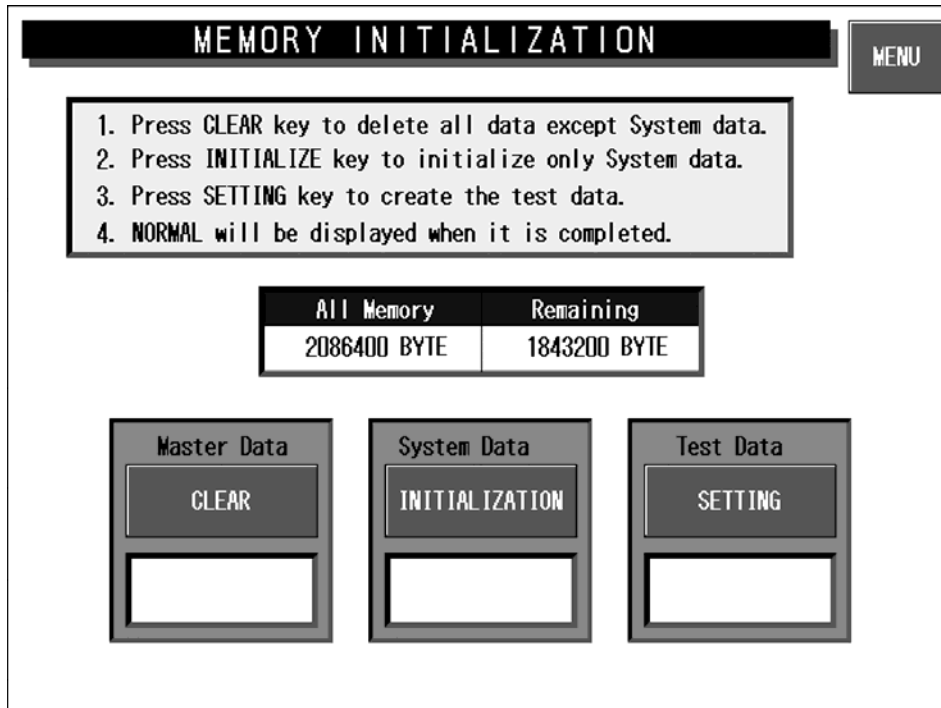

Memory Initialization Screen

Buttons/Display Fields	Function
MENU	Returns to the Test Menu 1/2 screen.
Master Data CLEAR	Clear master data. "Processing" is displayed during execution. "Normal" is displayed when the execution has ended normally. "Abnormal" is displayed when execution has ended abnormally.
System Data INITIALIZATION	Initialize system data (system master and machine master data). "Processing" is displayed during execution. "Normal" is displayed when the execution has ended normally. "Abnormal" is displayed when execution has ended abnormally.
Test Data SETTING	Set test data after master data has been cleared and system data has been initialized. "Processing" is displayed during execution. "Normal" is displayed when the execution has ended normally. "Abnormal" is displayed when execution has ended abnormally.

3.7 DISPLAY CHECK

Press the [Display Check] button on the Test Menu screen. Then, the display check screen appears. This procedure is used to check whether the screen shows an ideal color contrast or not. To adjust the color contrast, turn the knob on right side of the operating console.

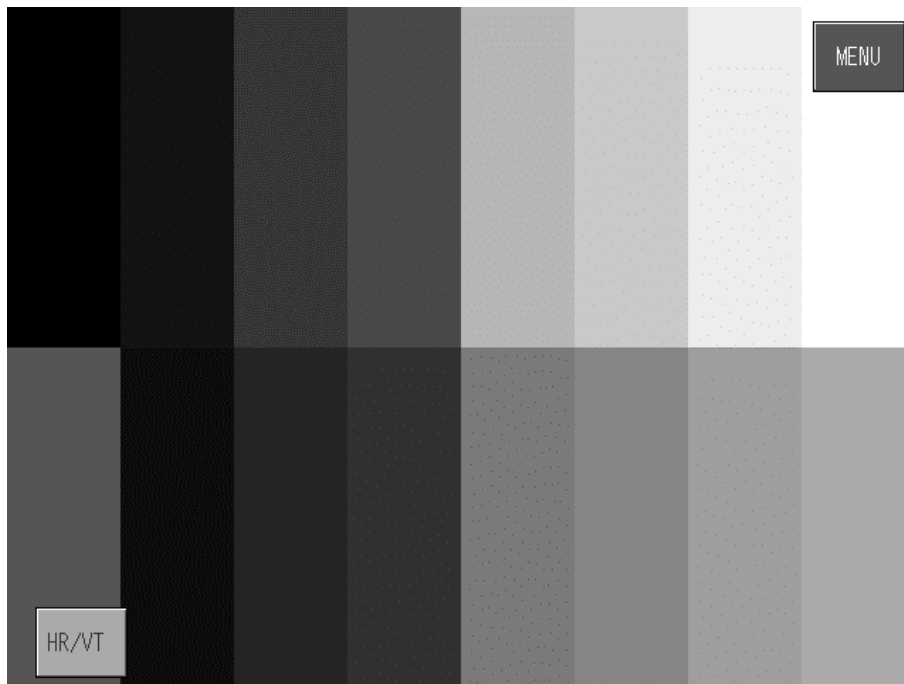

Display Check Screen (Vertical)

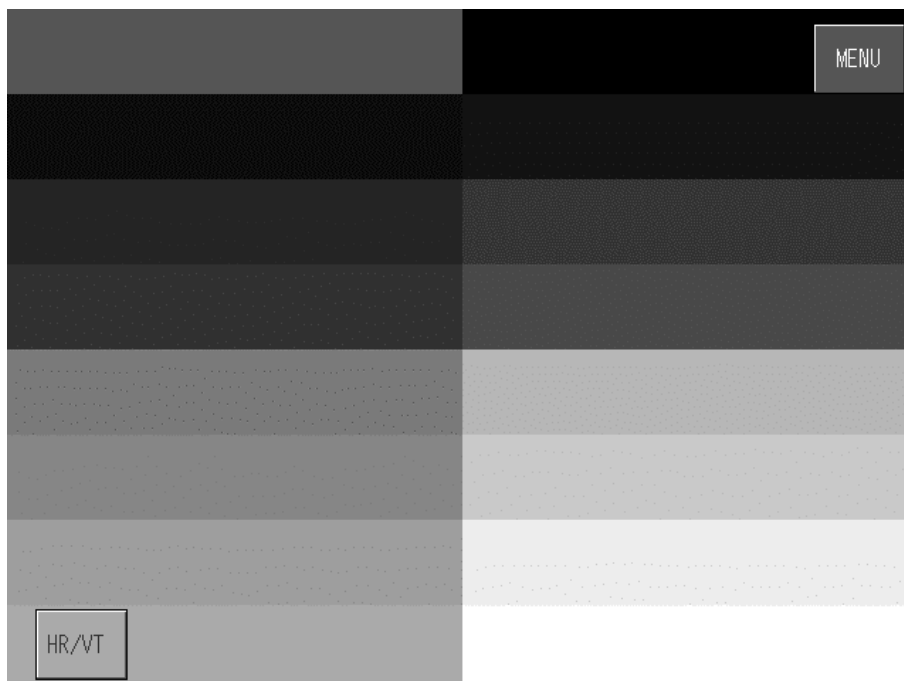

Display Check Screen (Horizontal)

Buttons/Display Fields	Function
MENU	Returns to the Test Menu 1/2 screen.
Horizontal/Vertical	Changes between horizontal and vertical color patterns.

3.8 SCALE CALIBRATION

Press the [Calibration] button on the Test Menu screen. Then, the Calibration screen appears.

3.8.1 A/D DATA INITIALIZATION, ZERO POINT/SPAN ADJUSTMENT

This procedure is used to initialize the A/D data, adjust the zero point, and perform span adjustment of the scale.

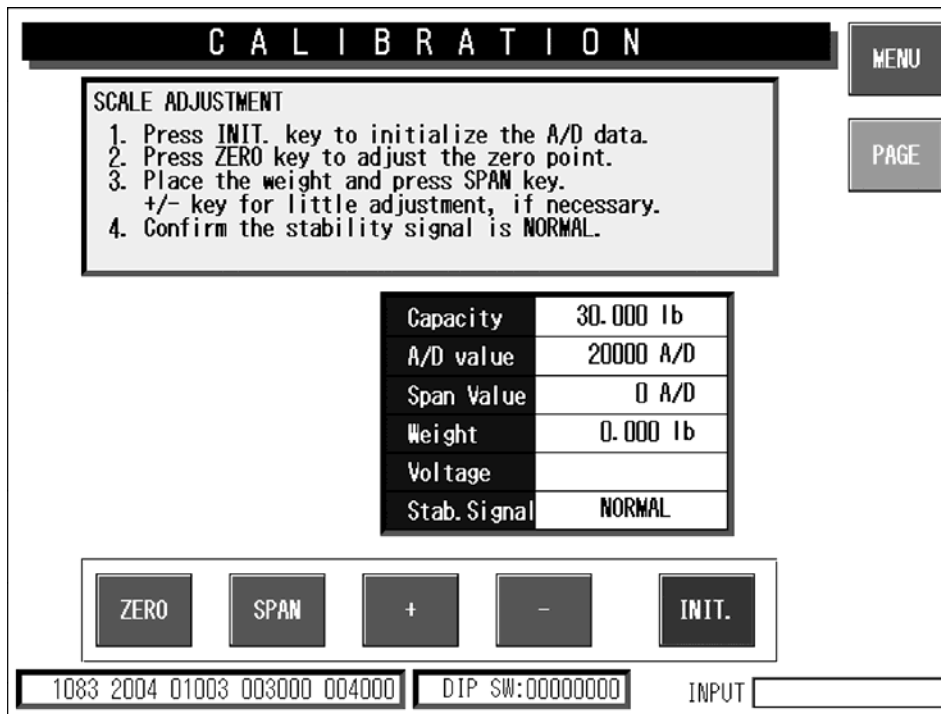

Calibration Screen

Buttons/Display Fields	Function
MENU	Returns to the Test Menu 1/2 screen.
PAGE	Changes to the scale adjustment screen after password has been entered. Inputting the command sends it directly to the scale board.
ZERO	Executes zero point adjustment.
SPAN	Executes span adjustment.
[+] [-]	Executes fine span adjustment using these buttons.
INITIALIZE	Executes the scale board initialization.
Capacity	Displays weighing capacity in "kg" based on scale board information.
A/D Value	Displays A/D (read) data (count value) in A/D units.
Span Value	Subtracts span data from the read data (the above mentioned A/D value) and displays the value (count value) in A/D units.
Weight	Displays the weight value in "kg" calculated from the A/D value based on the set district information.
Voltage	Displays the voltage.
Stability Signal	"Normal" is displayed when the first stability signal is received normally. The display goes blank if communication is unsuccessful.
Scale Setting Information	Displays basic performance data and country specific scale setting data.
DIP Switch Data	Displays scale board DIP switch setting status. Refer to the table on the following page.

■ DIP Switch Settings

DIP SW bit	Content	Set value
0	Board No. 0: Set with "X" command 1: "0" fixed	0
1	Storage command 0: "W" command prohibited 1: "W" command allowed	0
2	Test mode 0: "*" command prohibited 1: "*" command allowed	0
3	Movement average 0: 8 times 1: None	0
4	Zero bias 0: Yes 1: No	0
5	Sending weight 0: No 1: 20msec	0
6	A/D data 0: ASC-HEX 5byte 1: ASC-HEX 6byte	0
7	Analog filter 0: Software 1: Hardware	0

3.8.2 SCALE ADJUSTMENT

This procedure is used to select the weighing capacity., and create a command message to be sent to the scale.

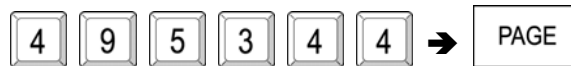

SCALE ADJUSTMENT										BACK
Capacity										
15 lb					30 lb					
Send Data		<input type="text"/>								
ReceiveData		<input type="text"/>								
A	B	C	D	E	F	G	H	I	Select <input type="button" value="ABC"/> <input type="button" value="abc"/> <input type="button" value="SEND"/>	
J	K	L	M	N	O	P	Q	R		
S	T	U	V	W	X	Y	Z	*		
INPUT <input type="text"/>										

Scale Adjustment Screen

Buttons/Display Fields	Function
BACK	Returns to the Calibration screen.
Capacity	Press the button that corresponds to the capacity to be selected. The button color will change to blue.
Select [ABC] [abc]	Select either "ABC" or "abc". These buttons select upper or lowercase letters for alphabetic input when creating a command message to send to the scale board. Select letter type by pressing the corresponding button. The button color will change to blue.
SEND	Send the command message to the scale unit.
Send Data	Displays command message data sent to the scale board.
Receive Data	Displays command message data received from the scale board.

3.9 PRINT ADJUSTMENT

Press the [Print Adjustment] button on the Test Menu screen. Then, the Print Adjustment 1/2 screen appears.

3.9.1 PRINT ADJUSTMENT 1/2

This procedure is used to set various printing conditions, and adjust various sensor levels for the selected printer.

PRINT ADJUSTMENT 1/2

1. Clear the Usage Distance before changing thermal head.
2. For Sensor Adjustment, press type of sensor to adjust and ▼ ▲ key for adjustment.

PRINTER No 1(MAIN 1) LABEL No 1

HEAD REGISTRATION 812 Ω SET

HEAD TYPE 0: LH4114 SET

HEAD UP SENSOR ● ON ○ OFF

HEAD ERROR CHECK SET

USAGE DISTANCE 0.0 km SET

LABEL SENSOR LEVEL 110

PEEL SENSOR LEVEL 123

MEMORY INITIALIZE SET

CASSETTE ○ ○ ○ ●

▲ ▼

INPUT

MENU

PAGE

STD. VALUE

DPM

Print Adjustment 1/2 Screen

Buttons/Display Fields	Function
MENU	Returns to Test Menu 1/2 screen.
PAGE	Changes to Print Adjustment 2/2 screen.
STANDARD VALUE	Changes the peel sensor standard (threshold) value data. Press this button to change the peel sensor level display field title to the peel sensor standard value and displays the present peel sensor level and standard value data. Press the display field after numeric entry to enable the standard value adjustment by pressing [▲] and [▼] buttons. Change label sensor standard (threshold) value data. Press this button to change the label sensor level display field title to the label sensor standard value and display present label sensor level and standard value data. Press the display field after numeric entry to enable the standard value adjustment by pressing [▲] and [▼] buttons.

Buttons/Display Fields	Function
DPM (Digital Potentiometer)	Adjust the sensitivity of each label sensor and peel sensor. Changes the label and peel sensor value Display Fields to green and makes it possible to change data. Adjust sensitivity by pressing one of the sensor value Display Fields and making a numeric entry. Sensitivity can be adjusted by pressing one of sensor value Display Fields after numeric entry. Press this button again to exit sensitivity adjustment mode and return the color to white.
Printer No.	Displays the printer number to be adjusted. Press the [SET] button after numeric entry to set a new printer to be adjusted. Data range is 1-4.
Label No.	Displays the label number that is linked with the numbers of the printer and the cassette to be adjusted. Set the label number in the label detail screen in System Mode. Default data: "1" for printer #1, "2" for printer #2, "6" for PP printer. Set the above-mentioned label sensor threshold (standard) value for each label number.
Head Resistance	Displays thermal head resistance (Ω , zero suppression). Press the [SET] button after numeric entry to set new head resistance. Data range is 0-999. The buzzer will sound if data is set beyond the specified range. Press the [SET] button without numeric entry to automatically set head resistance. "Processing" is displayed during the execution of automatic settings.
Head Error Check	Execute thermal head error check. "Processing" is displayed during processing. "Normal" is displayed when processing has ended normally. "Abnormal" is displayed when processing has ended abnormally.
Memory Initialization	Initialize printer memory. "Processing" is displayed during processing. "Normal" is displayed when processing has ended normally. "Abnormal" is displayed when processing has ended abnormally. Execute sensor levels, back feed calibration, initialization of the protection setting value against the head temperature rise, and acquisition of the head resistance, and initialization of label and cassette master data for the selected printer. Be sure to execute this procedure when the P-910 has been replaced.
Head Type	Displays thermal head type name. One of the following three types can be set: Press the [SET] button after numeric entry to set the desired head type. Default data: "0" LH4114 1: LH4116: Printing is not possible with the LH4116 head installed. Printing can be normally performed when "1" is set and the LH4114 installed. 2: BHP4312: Set the BHP4312 when using two color specifications. Set the DIP switch on the thermal board and "Thermal paper type" in "Print Adjustment 2/2" screen to "2: 2 color label".
Usage Distance	Thermal head movement distance ("km", zero suppression) is displayed. Press the [SET] button to clear head movement distance.

Buttons/Display Fields	Function
Cassette Status	Refer only when adjusting the cassette applicable printer. ○○○○: No cassettes are inserted. ○○○●: Cassette 1 is inserted. ●○○●: Cassette 2 is inserted. ●●○●: Cassette 3 is inserted. ○○●●: Cassette 4 is inserted. ●○●●: Cassette 5 is inserted. ○●●●: Cassette 6 is inserted. ●●●●: Cassette 7 is inserted.
Head Up Sensor	Displays head status. "ON" is illuminated when the head is set normally. "OFF" is illuminated when the head is up.
Label Sensor Level	Displays label sensor level. Press this button to finely adjust the label sensor level (display field will change to green) and press the (△▽) adjustment buttons. Press this button again to change the display to white and set adjustment data. The level range is 0-255.
Peel Sensor Level	Displays peel sensor level. Press this button to finely adjust the peel sensor level (display field will change to green) and press the (△▽) adjustment buttons. Press this button again to change the display to white and set adjustment data. The level range is 0-255.

3.9.2 PRINT ADJUSTMENT 2/2

This procedure is used to set printing conditions, label and peel sensor distances, and various labeling conditions for test label printing.

The screenshot shows the 'PRINT ADJUSTMENT 2/2' screen with the following settings:

- TEST-PRINTER No.:** PRN No. 1 (SET)
- TEST-FORMAT No.:** 52 (SET)
- TEST-LABEL LENGTH:** 37.0 mm (SET)
- PRINT DENSITY:** 5 (SET)
- LABEL SENSOR DIS.:** 50.0 mm (SET)
- LABEL GAP:** 2.5 mm (SET)
- PRINT SPEED:** 100 mm/sec (SET)
- PEEL SENSOR DIS.:** 11.0 mm (SET)
- FEED:** 7.5 mm (SET)
- FEED (STOP):** 3.5 mm (SET)
- PAPER TYPE:** 1:STANDARD (SET)
- *TEST PRINT LABEL PRINT:** NORMAL (CHECKER)
- BACKFEED CONTROL:** NO (YES)
- BACKFEED LENGTH:** 45mm, 60mm, 80mm, 1.0 mm
- HEAT PROTECTION:** NO (YES) (SPECI)
- INPUT:** []

Print Adjustment 2/2 Screen

Buttons/Display Fields	Function
MENU	Returns to the Test Menu 1/2 screen.
PAGE	Changes to the print adjustment (head information) screen.
Printer No.	Displays the number of the printer to be adjusted. Press the [SET] button after a numeric entry to change the number of the printer to be adjusted. The data range is 1-4. The buzzer will sound if data is entered outside the range or no data is entered.
Print Density	Displays the set print density. Press the [SET] button after a numeric entry to set the print density. The data ranges from 0 (lightest) to 9 (darkest), and the buzzer will sound if data is entered outside the range or no data is entered. The default value is "5".
Print Speed	Displays the set print speed (mm/sec). Press the [SET] button after a numeric entry to set the print speed. The data range is 60-130 (in units of 10mm/sec.). The default value is "100mm/sec.". A slower print speed results in a higher print quality.
Test Format No.	Displays the test label format number (2 digits) to be referred to for test printing or label feeding. Press this button after a numeric entry to set the label format for the test print. The data range is 1-99, and the buzzer will sound if data is entered outside the range or no data is entered. The default value is the default format set in the printer.
Label Sensor Distance	Displays the set label sensor distance (mm). The entered data can be set as the printer label sensor distance by pressing the [SET] button after a numeric entry. The data range is 1-999 in increments of 0.1mm. The default value is 41.0mm.

Buttons/Display Fields	Function
Peel Sensor Distance	Displays the set peel sensor distance (mm). The entered data can be set as a peel sensor distance of the objective printer by pressing the [SET] button after a numeric entry. The data range is 1-999 in increments of 0.1mm. The default value is 11.0mm.
Test Label Length	Displays label length (mm) for test printing. The entered data can be set as the printer label length by pressing the [SET] button after a numeric entry. The data range is 1-9999 in increments of 0.1mm. A buzzer will sound if data is entered outside the range or no data is entered. The default value is the label length of the above-mentioned test format number. The label will be fed for the distance of the label and gap lengths.
Label Gap	Displays the set gap length (mm). The entered data can be set as a gap length of the printer by pressing the [SET] button after a numeric entry. The data range is 1-999 in increments of 0.1mm. A buzzer will sound if data is entered outside the range or no data is entered. The default value is 2.5mm.
Feed	Displays the set feed length (mm). The entered data can be set as the printer feed length by pressing the [SET] button after a numeric entry. The data range is 1-999 in increments of 0.1mm. The default value is 7.5mm. This data becomes the back feed length when the back feed control is performed.
Feed (Stop)	This is effective only when the automatic label applicator is used. A label is issued leaving the set feed stop length, and fed for the length immediately before it is sucked by the applicator. The set feed stop length is displayed. Press the [SET] button after a numeric entry to set the feed stop length of the printer. The data range is 1-999 in units of 0.1mm. The default value is 3.5mm.
Test Print (Label Print)	Select the print pattern when test printing is performed. Press either "Normal" or "Checker" to select the item and change the button color to blue. When test printing is performed, this selection information will be used. The default data is "Checker".
Test Print (Back Feed Control)	Select the back feed function when test printing is performed. Press either "YES" or "NO" to select the desired function and change the button color to blue. <i>Note: This setting is applied only to the test print. Back feed settings for normal printing can be performed in the Label Detail Settings in the System Menu.</i>
Paper Type	Displays the type of thermal paper selected. Press the [SET] button after a numeric entry to set the type of thermal paper to be used in the printer. The data range is 0-9 with the following parameters: 1: Standard label 2: Two color label 3-9: Not registered The default value is "1".
Back Feed Length	A loss is caused in the feeding length for each roller due to the reverse rotation of the motor, gears, and print roller during back feed operation. This function is used to make up that loss. It does not influence the store name, address, and ruled lines for each existing format. However, it is used in the case of a format without sufficient space. The height (approximation) of the set label and the back feed correction length (mm). Press the top/bottom select button to determine the label top/bottom type for correction length. Select one of three types: 45mm, 60mm, or 80mm. The selected size field changes to blue. Press the correction length display field after a numeric entry to set the correction length for the selected height. The data range is 0.0-9.9mm.

Buttons/Display Fields	Function
Heat Protection	<p>Displays the heat protection selection for the set head. Press the [SELECT] button to select head temperature increase protection. The button color will change to blue.</p> <p>No: Print even if the head temperature increases. (Default) Yes: Stop printing for about 0.5 seconds if the head temperature increases.</p> <p>The print density is high, and it is a level where the temperature over rises by 1000 piece continuous printing. The print density is high and the head will overheat after continuously printing 1000 labels.</p> <p>Usually set to "No".</p>

3.10 ROM VERSION DISPLAY

Press the [ROM Version] button on the Test Menu screen. Then, the ROM Version screen appears. This procedure is used to display the ROM version of connected devices. It cannot display devices that are not connected.

ROM VERSION			
MAIN MANAGEMENT SOFTWARE		B0506	
SOFTWARE	VERSION	SOFTWARE	VERSION
MAIN	B0507		
SCALE	J0503B		
WRAP APP	B0508		
		BOOT ROM	J0568E
LABEL APP	B0509	OS	5.3.1-1.2/3
LABEL BOOT	J0523A	ELAN	I2NET 5
		ILAN	I2NET 5
PROCESS BD	J0505B		

ROM Version Display

Buttons/Display Fields	Function
MENU	Returns to the Test Menu 1/2 screen.
Version Display	Displays the ROM version of connected devices. The sample data for the above-mentioned display is different from actual ROM version numbers.

3.11 COMMUNICATION CHECK

Press the [Communication Check] button on the Test Menu screen. Then, the Communication Check screen appears. This procedure is used to perform various communication checks.

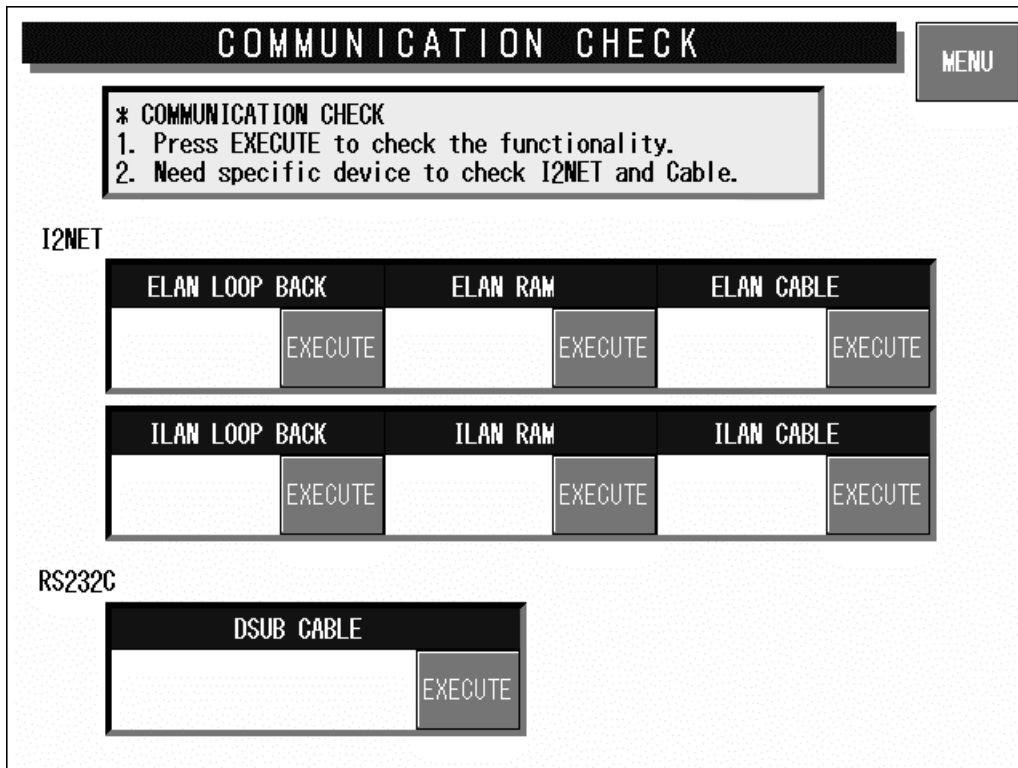

Communication Check Screen

Buttons/Display Fields	Function
MENU	Returns to the Test Menu 1/2 screen.
ELAN Loop Back	Press the [EXECUTE] button to execute a send and receive loop test within the board.
ELAN RAM	Press the [EXECUTE] button to execute a send and receive buffer memory test.
ELAN Cable	Connect the IF-21FD to the cable to confirm the response. Press the [EXECUTE] button to execute a cable test.
ILAN Loop Back	Press the [EXECUTE] button to execute a loop back test.
ILAN RAM	Press the [EXECUTE] button to execute an ILAN RAM test.
ILAN Cable	Connect the IF-21FD to the cable to confirm the response. Press the [EXECUTE] button to execute a cable test.
RS232C Dsub Cable	Press the [EXECUTE] button to execute a cable test and RS-232C input/output check. Use the loop back connector for testing.
Display Status	“Operating” is displayed during execution. “Normal” is displayed when the execution has ended normally. “Abnormal” is displayed when execution has ended abnormally.

3.12 OPTION CHECK

Press the [Option Check] button on the Test Menu screen. Then, the Option Check screen appears. This procedure is used to perform scanner and card slot checks.

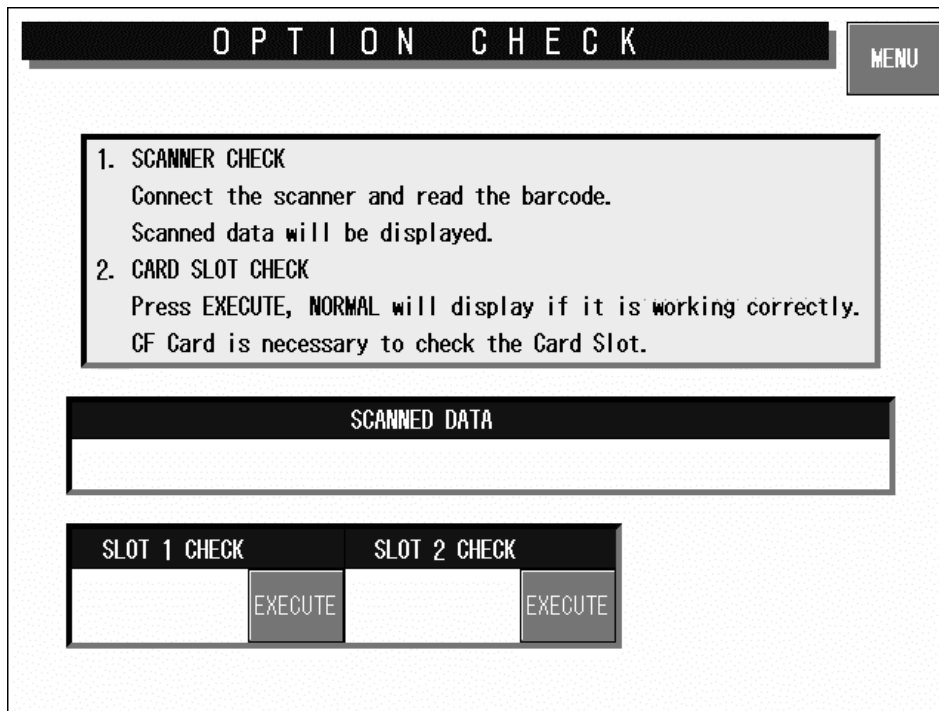

Option Check Screen

Buttons/Display Fields	Function
MENU	Returns to the Test Menu 1/2 screen.
Scanned Data	Displays the OCR data when a barcode is read with the scanner.
Slot 1 Check	Insert the formatted CF card (8M, 16M) and press the [EXECUTE] button to execute an operation check.
Slot 2 Check	Insert the formatted CF card (8M, 16M) and press the [EXECUTE] button to execute an operation check.
Display Status	<p>“Operating” is displayed during execution.</p> <p>“Normal” is displayed when the execution has ended normally.</p> <p>“Abnormal” is displayed when execution has ended abnormally.</p>

3.13 MEMORY DATA CHANGE

Press the [Memory Data Change] button on the Test Menu screen. Then, the Memory Data Change Menu screen appears.

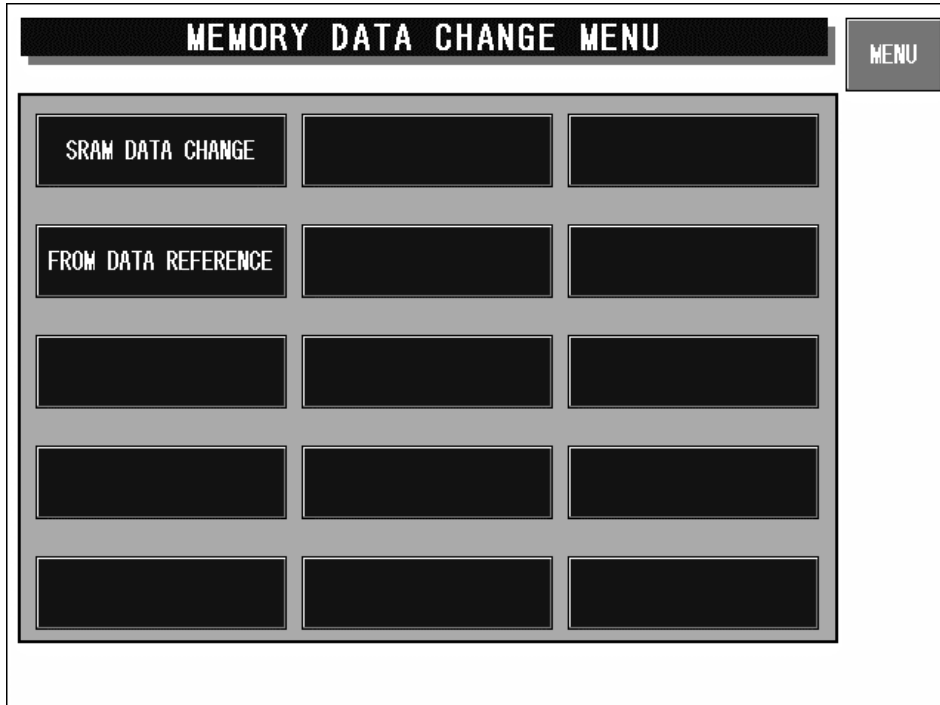

Memory Data Change Menu Screen

Buttons/Display Fields	Function
MENU	Returns to the Test Menu 1/2 screen.
SRAM Data Change	Press this button to change the display to the SRAM data change screen. SRAM data can be changed and confirmed on the memory dump list.
FROM Data Reference	Changes to the FROM data reference screen. FROM data can be confirmed on the memory dump list.

3.13.1 SRAM DATA CHANGE

Press the [SRAM Data Change] button on the Memory Data Change Menu screen. Then, the SRAM Data Change screen appears. This procedure is used to confirm or change SRAM data on the memory dump list.

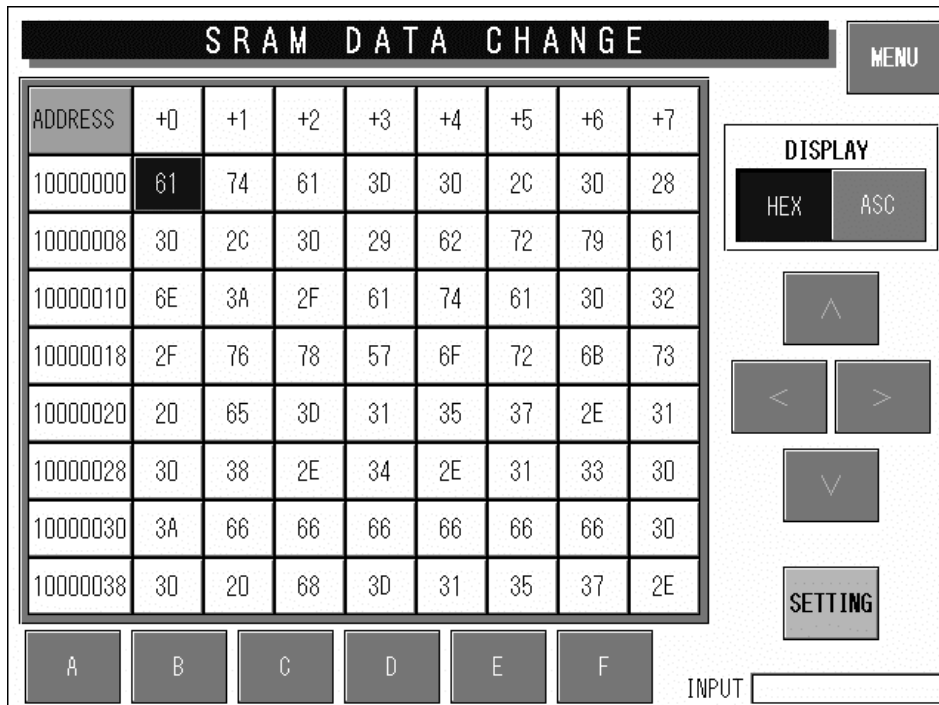

SRAM Data Change Screen

Buttons/Display Fields	Function
MENU	Returns to the Memory data change menu screen.
SRAM Data Button	Press any button (address position) to change its color to blue and enable settings for modification. The memory data status is displayed.
Display	Select either "HEX" or "ASC" data formats. Press one of these buttons to select the data format and the selected button will change to blue. The data display format will change in the SRAM data display field.
Up/Down Left/Right	Press these buttons to move active SRAM data (address) positions. Press these buttons without a numeric entry to move the cursor in the desired direction. Press one of these buttons after a numeric entry to move the cursor to the entered address position.
SETTING	Press this button after numeric entry to set the entered data to the memory data to be changed (RAM data field is blue). The data range is 0-FF. An operation error buzzer will sound if data is entered outside the range or there is no numeric entry made.

Note: Do not change the set values or the program will not operate normally.

3.13.2 FROM DATA REFERENCE

Press the [FROM Data Reference] button on the Memory Data Change Menu screen. Then, the FROM Data Reference screen appears. This procedure is used to confirm FROM data on the memory dump list.

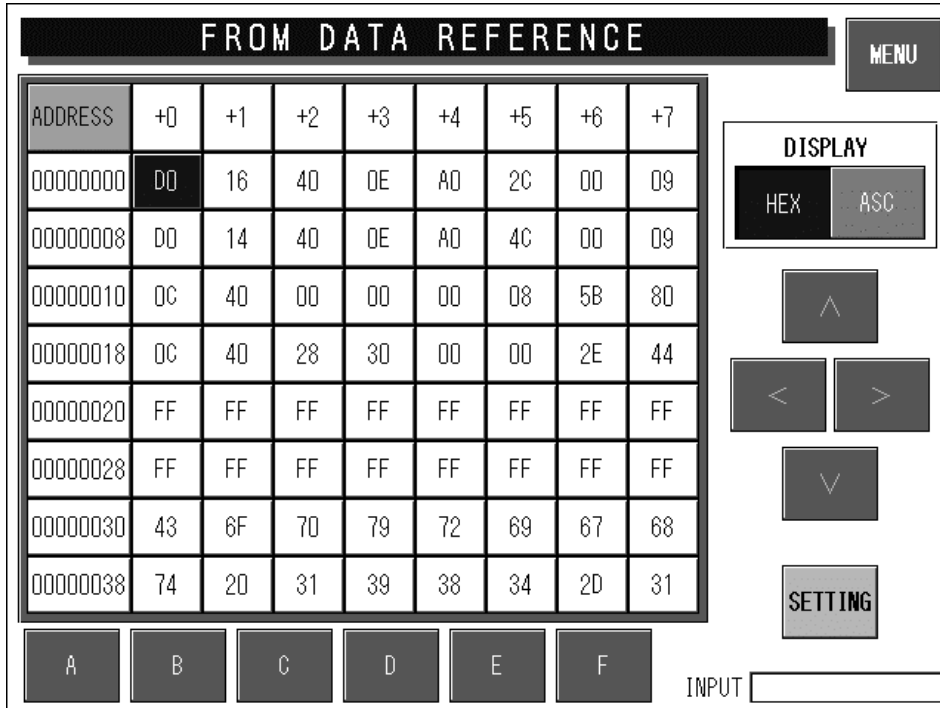

FROM Data Reference Screen

Buttons/Display Fields	Function
MENU	Returns to the Memory data change menu screen.
FROM Data Button	Press any button to change its color to blue and display the set memory data.
Display	Select either "HEX" or "ASC" data formats. Press one of these buttons to select the data format and the selected button will change to blue. The data display format will change in the FROM data display field.
Up/Down Left/Right	Press these buttons to move the displayed FROM data position. Press these buttons without a numeric entry to move the cursor in the desired direction. Press one of these buttons after a numeric entry to move the cursor to the entered address position.
SETTING	This screen is used only for data reference and an error will occur if this button is pressed.

Note: Do not change the set values or the program will not operate normally.

3.14 TIME AND DATE SETTING

Press the [Time & Date Setting] button on the Test Menu screen. Then, the Time and Date Setting screen appears. Enter the date (DD-MM-YYYY) and press the Date field to set. In the same manner, enter the time (HH:MM:SS) and press the Time field to set.

The screenshot shows the 'TIME AND DATE SETTING' screen. At the top, there is a title bar with the text 'TIME AND DATE SETTING' and a 'MENU' button on the right. Below the title bar, a text box contains the instruction: 'Set the Date and Time. Input the date (8 digits) according to the displayed order. (DDMMYYYY)'. Underneath this instruction are three input fields. The first is labeled 'DATE (DD-MM-YYYY)' and contains the text '14-MAR-2005'. The second is labeled 'TIME (HH:MM:SS)' and contains '16:10:05'. The third is labeled 'JULIAN DATE' and contains '73-2005'. At the bottom right of the screen, there is an 'INPUT' label followed by a small empty text box.

Time and Date Setting Screen

Buttons/Display Fields	Function
MENU	Returns to the Test Menu 1/2 screen.
DATE	Press this button after a numeric entry to set the date. Non-existent calendar dates cannot be set. Data format is day (2 digits), month (2 digits), and year (4 digits).
TIME	Press this button after a numeric entry to set the time. Data format is hour (2 digits), minute (2 digits), and seconds (2 digits). The data range is 0-235959. Press this button without a numeric entry to set seconds to "00".

3.15 PROGRAM DOWNLOADING

Press the [Program Download] button on the Test Menu screen. Then, the Option Device Download screen appears.

There are three programs that operate this machine; Main control program that operates the PC board, the program that operates the label applicator, and the program that operates the wrapping unit.

The main control program boots the data in the CF card to the PC board when the power is turned ON.

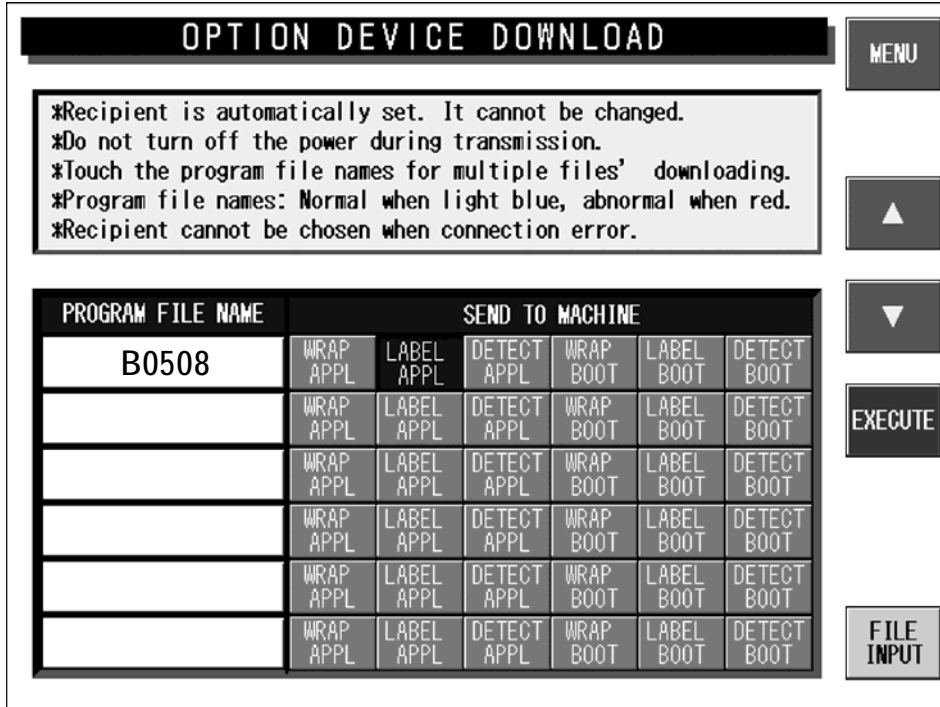

Option Device Download Screen

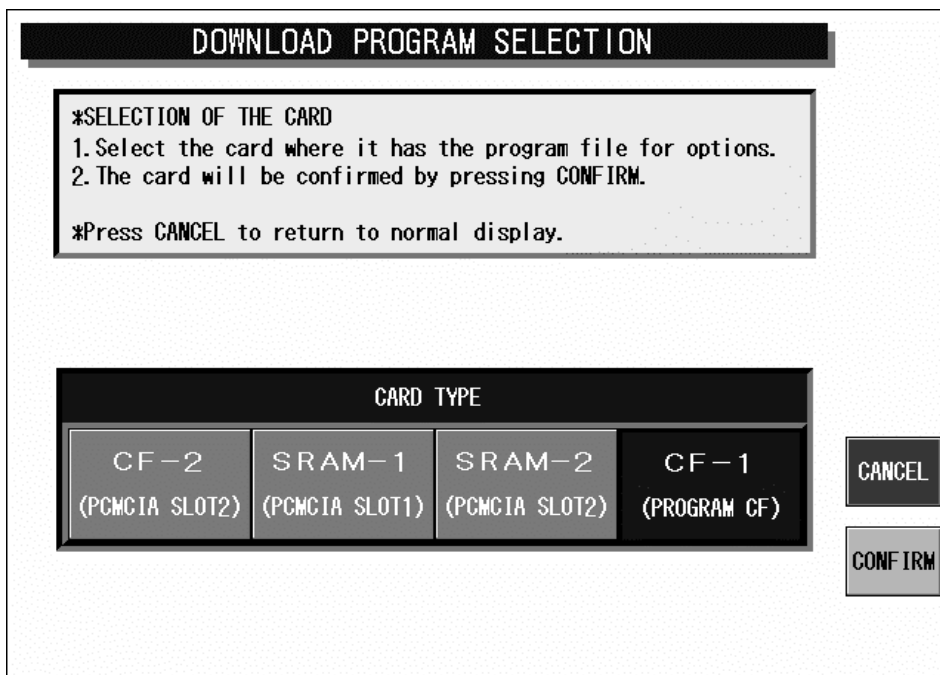

Download Program Selection Screen

Buttons/Display Fields	Function
MENU	Returns to the Test Menu 1/2 screen.
EXECUTE	<p>Display the download execution confirmation dialog.</p> <p>Press the [EXECUTE] button on the dialog screen to transmit the selected program file to the selected destination.</p> <p>Press the [CANCEL] button on the dialog screen to cancel downloading and close the screen.</p> <p>Be sure not to turn off the power while downloading.</p>
Program File Name	<p>Displays the option program file names stored in the program CF.</p> <p>Press the display field to select the file name and change its color to yellow.</p>
FILE INPUT	<p>Press this button to display the download program selection screen.</p> <p>Press the corresponding button to select the media where the downloaded program file is stored.</p> <p>Press the [CONFIRM] button to re-display the option device download screen for the selected media.</p>
Send to Machine	The option device program file stored in the program CF will automatically select the destination and the button color will change to blue.

3.16 WRAPPER / APPLICATOR ADJUSTMENT

Press the [Wrapper/Applicator Adjust] button on the Test Menu screen. Then, the Wrapper Check screen appears.

3.16.1 WRAPPER CHECK

Enter the test item number using the numeric keys or press the desired item field on the screen, then press the [EXECUTE] button to perform operation check.
To stop operation check, enter "0" and press the [EXECUTE] button.

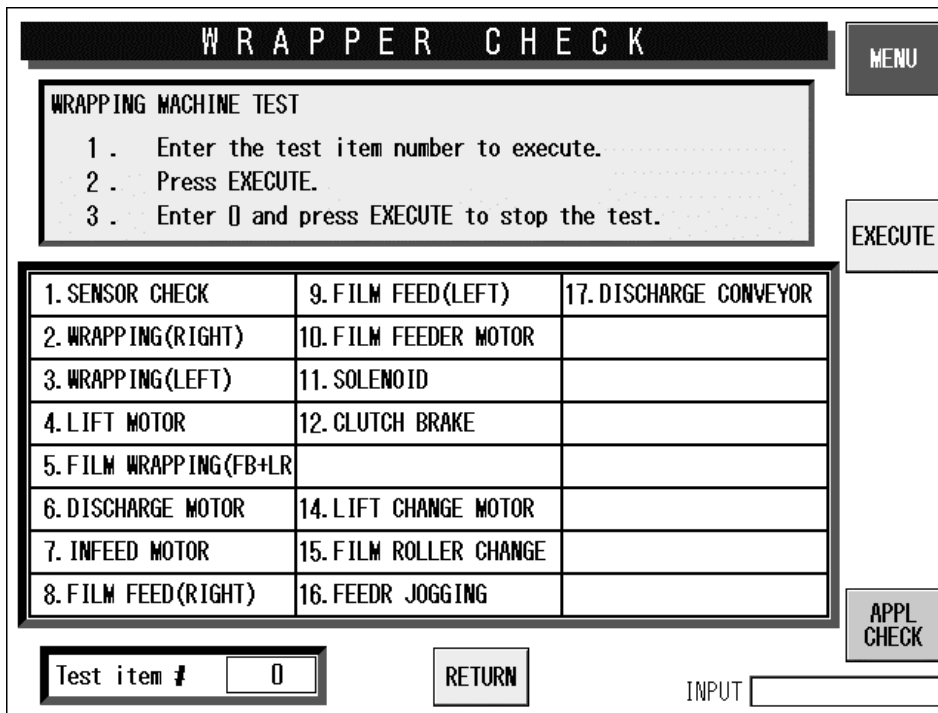

Wrapper Check Screen

Buttons/Display Fields	Function
MENU	Returns to the Test Menu 1/2 screen. Displays the dialog screen when there is a commodity on the lift through an operation series execution.
APPLICATOR CHECK	Press this button to change to the Applicator Check screen. The button name changes between "Applicator Check" and "Wrapper Check" at each depression.
EXECUTE	Executes a specified test operation. The display field color changes to light blue during operation. The operation will stop when pressed after "0" entry.
RETURN	Resumes wrapper operation.

3.16.2 APPLICATOR CHECK

Press the [APPLICATOR CHECK] button on the Wrapper Check screen. Then, the Applicator Check screen appears.

Enter the test item number using the numeric keys or press the desired item field on the screen, then press the [EXECUTE] button to perform operation check.

To stop operation check, enter "0" and press the [EXECUTE] button.

APPLICATOR CHECK		
MENU		
LABEL APPLICATOR TEST 1. Enter the test item number to execute. 2. Press EXECUTE. 3. Enter 0 and press EXECUTE to stop the test.		
EXECUTE		
1. APPL CONTROL SENSOR	9. FAN ROTATION	
2. APPL SAFETY SENSOR	10. WRAPPER(R)+1 APPL.	
3. LEFT AND RIGHT MOVE	11. WRAPPER(R)+2 APPL.	
4. BACK AND FORTH MOVE	12. WRAPPER(L)+1 APPL.	
5. UP AND DOWN MOVE	13. WRAPPER(L)+2 APPL.	
6. AXIS DIRECTION MOVE		
7. 1ST MACH. 1 APPL.		
8. 2ND MACH., 1 APPL.		
WRAPPER		
Test item #	0	RETURN
		INPUT

Applicator Check Screen

Buttons/Display Fields	Function
MENU	Returns to the Test Menu 1/2 screen. Displays the dialog screen when there is a commodity on the lift through an operation series execution.
WRAPPER	Changes to the Wrapper Check screen. Press this button during operation to change to the Wrapper Check screen after operation stops.
EXECUTE	Executes a specified test operation. The display field color changes to light blue during operation. The operation will stop when pressed after "0" entry.
RETURN	Press this button to resume automatic applicator operation.

3.17 WRAPPER SETUP

Press the [Wrapper Setup] button on the Test Menu screen. Then, the Wrapper Set 1/2 screen appears. This procedure is used to perform the wrapper initialization, set various machine conditions, adjust the roll and film positions, and set the labeling direction.

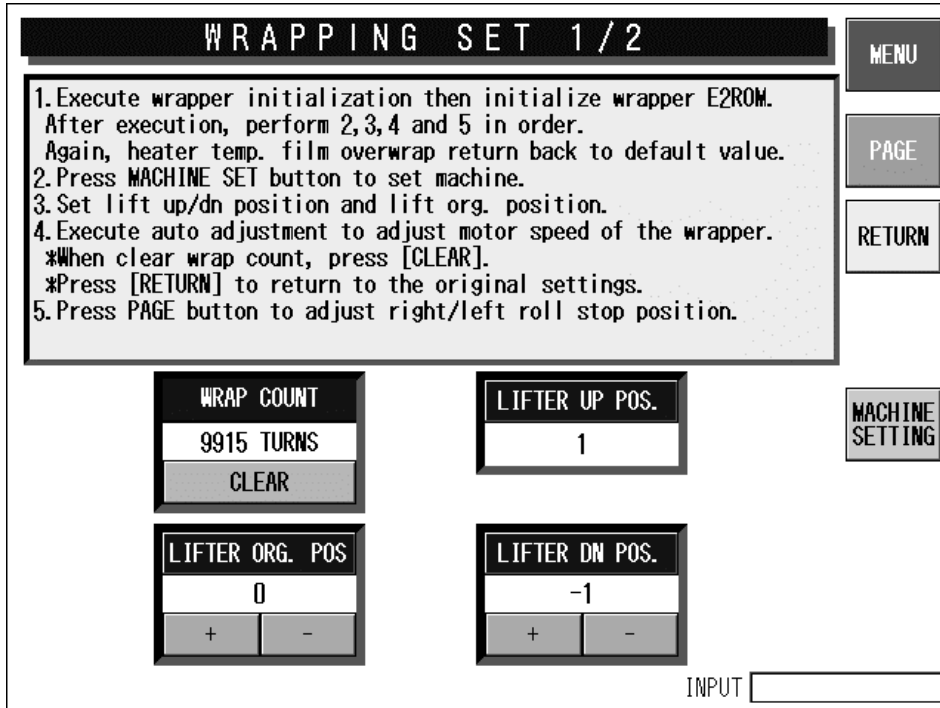

Wrapper Set 1/2 Screen

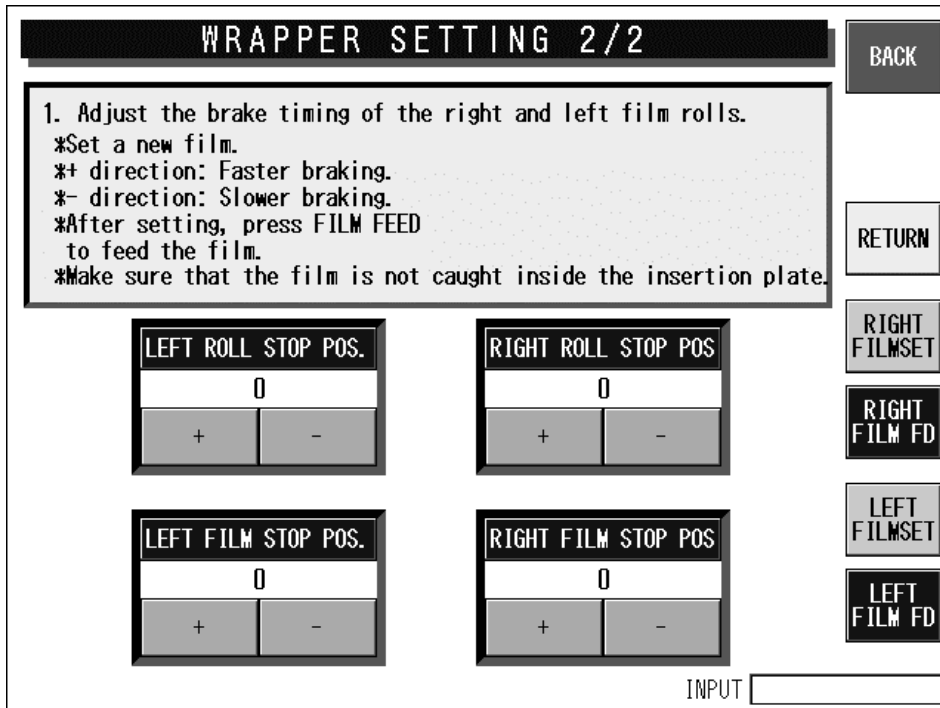

Wrapper Set 2/2 Screen

Buttons/Display Fields	Function
MENU	Returns to the Test Menu 1/2 screen.
PAGE	Turns over screens.
RETURN	Performs wrapper and applicator return operations.
MACHINE SETTING	Changes to the Machine Setting 2/2 screen.
BACK	Returns to the previous screen.
FILM SET (Left/Right)	Performs the designated film setting.
FILM FEED (Left/Right)	Performs the designated film feeding.
Wrap Count	<p>Displays the total wrapping frequency.</p> <p>Press the [CLEAR] button to display the clear confirmation dialog.</p> <p>Press the [EXECUTE] button to clear the wrap count.</p> <p>Press the [CANCEL] button to close the dialog screen without clearing the wrap count.</p>
Lifter Original Point Position	<p>Displays the lifter original point position data.</p> <p>The data range is 0-99. (Default value: 0)</p> <p>The lift moves to the original position when the data is set. If an automatic applicator is used, an error will occur if the applicator cover is closed when the lift starts moving.</p> <p>This becomes the default value when the wrapper is initialized.</p>
Lifter Up Position	<p>Displays the lifter up position. The data range is 0-99. (Default value: 0)</p> <p>The lift moves to the upper center position when the data is set.</p> <p>If an automatic applicator is used, an error will occur if the applicator cover is closed when the lift starts moving.</p> <p>This becomes the default value when the wrapper is initialized.</p>
Lifter Down Position	<p>Displays the lifter down position. The data range is 0-99. (Default value: 0)</p> <p>The lift moves to the lower center position when the data is set.</p> <p>If an automatic applicator is used, an error will occur if the applicator cover is closed when the lift starts moving.</p> <p>This becomes the default value when the wrapper is initialized.</p>
Roll Stop Position (Left/Right)	<p>Displays the film roll stop position.</p> <p>Adjust the stop position using [+] or [-].</p>
Film Stop Position (Left/Right)	<p>Displays the film stop position.</p> <p>Adjust the stop position using [+] or [-].</p>
[+] [-]	<p>One point is added to the set data by pressing the [+] button without a data entry. One point is subtracted from the set data by pressing the [-] button without a data entry.</p> <p>The entered data is set as the plus data by pressing the [+] button with a data entry.</p> <p>The entered data is set as the minus data by pressing the [-] button with a data entry.</p> <p>The lift will start moving according to the data after it is set.</p>

3.18 APPLICATOR ADJUSTMENT

Press the [Applicator Adjustment] button on the Test Menu screen. Then, the Applicator Adjustment screen appears. This procedure is used to perform the applicator related adjustment such as the suction position, the labeling position, etc. On the Initialize Applicator screen, confirm and clear the applicator pasting count and initialize applicator memory.

APPLICATOR ADJUSTMENT

1) Adjust the suction position.
 2) Adjust the labeling position for 0 and -90 degrees.
 3) Change the Machine No. and perform 1) and 2).
 *Press PAGE button to go to E2ROM and label count initialization.

MACH. No. Lbl Pos.X Y Z

*Suction Position Adjustment

TO LEFT 1 mm	TO REAR 3 mm	TO BOTTOM 1.5 mm
LEFT RIGHT	REAR FRONT	LOW UP

*Lbl. Pos. ANGLE & POS.

TO LEFT 2 mm	TO REAR 10 mm	0 DG
LEFT RIGHT	REAR FRONT	LT. ROT. RT. ROT.

MENU

PAGE

RETURN

READY TO SUCK

NO PRN CONFIRM

PRINT CONFIRM

CONTIN. RUN

PASTING CONFIRM

INPUT

Applicator Adjustment Screen

INIT. APPLICATOR

1. Execute labeler initialization to initialize the labeler E2ROM.
 When executed adjust the applicator on labeler adjustment screen.
 * Press CLEAR to clear the application count.
 * Press PAGE to go to the display for applicator adjustment.

MENU

PAGE

LABELING COUNT

3205cnt

CLEAR

INIT. APPLICATOR

EXECUTE

FAN OFF DURATION

10min

SET

INPUT

Initialize Applicator Screen

Buttons/Display Fields	Function
MENU	Returns to the Test Menu screen after saving adjustment data.
PAGE	Turns over screens.
RETURN	Performs wrapper and applicator return operations.
PAGE	Turns over screens.
Machine No.	Displays the printer number to be adjusted. Change the number by pressing after a numeric entry. The data range is 1-4. Do not have the meaning excluding 1 and 2 though (However, 4 or less in the connected machine).
Suction Position (Left/Right)	Displays right/left suction position data (0mm, 1-3 mm left; 0 mm, 1-3 mm right). Press the [RIGHT] or [LEFT] button without data entry to adjust the position in 1mm increments. Press the [RIGHT] or [LEFT] button after a numeric entry to set position data. Default value: (0 mm...No correction)
Suction Position (Front/Rear)	Displays front/rear adjustment data (0mm, 1-3mm front; 0mm, 1-3 mm rear). The data range is 0-3. Press the [FRONT] or [REAR] button without data entry to adjust the position in 1mm increments. Press the [FRONT] or [REAR] button after a numeric entry to set position data. Default value: (0mm...No correction)
Suction Position (Up/Down)	Displays up and low position adjustment data (0 mm, 1-3.0 mm up; 0 mm, 1-3.0 mm down). The data range is 0.0-3.0 Press the [UP] or [LOW] button without a data entry to adjust the position in increments of 0.1 mm. Press the [UP] or [LOW] button after a numeric entry to set position data. Default value: (0 mm...No correction)
Ready to Suck	The applicator stands by in the uppermost position in front of the called printer.
No Print Confirmation	The applicator starts suction (based on the adjustment data) for the called printer. The label is not printed. Confirm the suction position and set the adjustment data again if necessary.
Print Confirmation	The applicator starts suction (based on the adjustment data) for the called printer. The label is printed. Confirm the suction position and set the adjustment data again if necessary.
Label pasting position right/ left adjustment	Displays right and left position adjustment data for label pasting (0 mm, 1-8 mm left; 0 mm, 1-8 mm right). The data range is 0-8. Press the [RIGHT] or [LEFT] key without a data entry to adjust the position in 1mm increments. Press the [RIGHT] or [LEFT] key after a numeric entry to set the position adjustment data. Default value: (0 mm...No correction)
Label pasting position front/rear adjustment	Displays front and rear position adjustment data for label pasting (0mm, 1-10mm left; 0mm, 1-10 mm right). The data range is 0-10. Press the [FRONT] or [REAR] key without a data entry to adjust the position in 1 mm increments. Press the [FRONT] or [REAR] key after a numeric entry to set the position adjustment data. Default value: (0 mm...No correction)
Label pasting position rotation adjustment	Displays rotation angle position adjustment data for label pasting (0°, 1°-5° left; 1°-5° right). The data range is from 0 to 5. Press the [RIGHT ROTATION] or [LEFT ROTATION] button without a data entry to adjust the position 1° increments. Press the [RIGHT ROTATION] or [LEFT ROTATION] button after a numeric entry to set the position adjustment data. Default value: (0°...No correction)

Buttons/Display Fields	Function
Pasting Confirmation	Label feeding is executed from the called printer and the applicator performs label suction and pasting operation. After sucking the label, the discharge pusher is pushed out and label pasting is performed to the discharge pusher. After confirming the result of pasted label on the pusher, set the adjustment data again if necessary.
Continual Run	Changes to the continual run screen. Press the [EXECUTE] button to run the continual pasting test after the continual run count and pasting angle have been set.
Labeling Count	Displays the total number of labels pasted. Press the [CLEAR] button to display the clear confirmation dialog. Press the [EXECUTE] button to clear the label count and "0" will be displayed. Press the [CANCEL] button to close the dialog without clearing the label count.
Initializing Applicator	Press the [EXECUTE] button to display the initialization confirmation screen. Press the [EXECUTE] button again to initialize E2ROM. Press the [CANCEL] button to cancel initialization. "Operating" is displayed during execution. "Normal" is displayed when the execution has ended normally. "Abnormal" is displayed when execution has ended abnormally.
Fan OFF Duration	Set the fan shut down delay time after label pasting. Press the [SET] button after a numeric entry to set this value. The fan does not stop when "0" minutes are set. The default value is 10 minutes.

Note 1: Label feeding is executed with the default label size for the selected printer by pressing the [FEED] key. An automatic applicator error will occur if the applicator cover is closed.

2: The applicator adjustment settings data is stored in the applicator control board and backed up to the CF-1 (file name haridata.csv). When applicator initialization is executed, the applicator initialization control board is initialized and an inquiry is made whether or not to recover when there is backup data on CF-1.

4

SYSTEM MODE**CONTENTS**

4.1	STARTING PROCEDURE	4-2
4.2	SYSTEM MENU	4-4
4.3	TCP/IP SETUP	4-6
4.4	SYSTEM DATA SETUP	4-8
4.5	AUTO PROGRAM SETTING.....	4-10
4.6	LABEL PRINT COMBINATION SETUP	4-13
4.7	FORMAT SETTING	4-23
4.8	PRINT ITEM SETTING.....	4-24
4.9	FILE CHECK	4-26
4.10	FILE INPUT/OUTPUT	4-28
4.11	FREE MESSAGE NAME REGISTRATION	4-32
4.12	LINK MASTER ERROR SETUP	4-33
4.13	WRAPPER SETTING	4-34
4.14	DISPLAY ERROR LOG	4-35
4.15	SRAM DATA INPUT/OUTPUT.....	4-39
4.16	FILE TRANSFER MENU	4-45

4.1 STARTING PROCEDURE

1. Turn the Main Power Switch lever clockwise to power ON the machine.

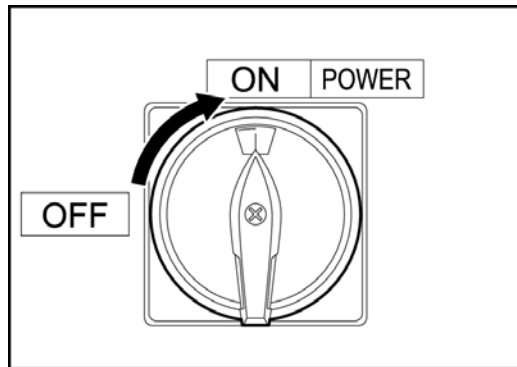

2. The Check of Return Operation screen appears. Press the [RETURN] button.

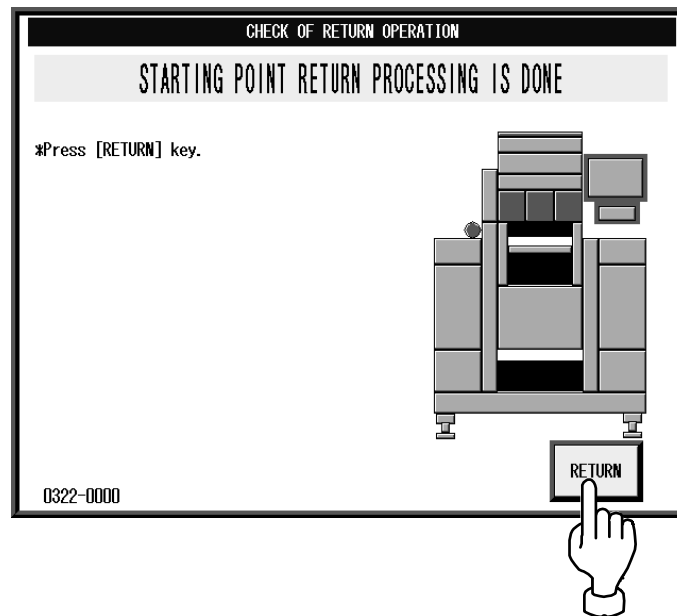

3. The initial screen appears. Press the [MENU] button on the screen.

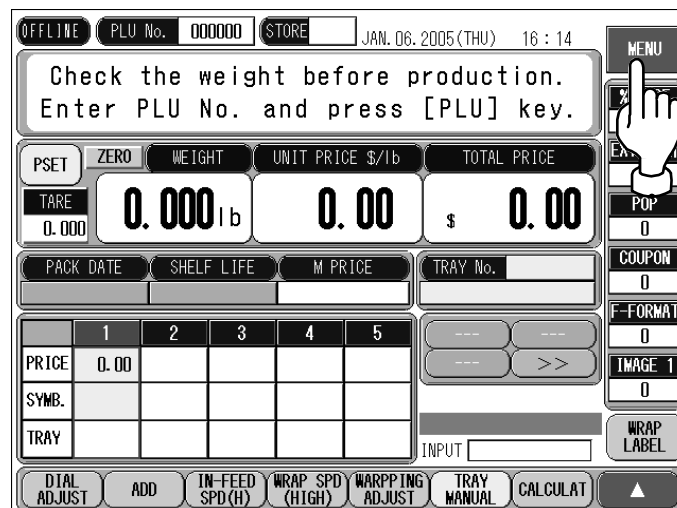

4. Enter "495344" using the numeric keys and press the [PLU] stroke key.

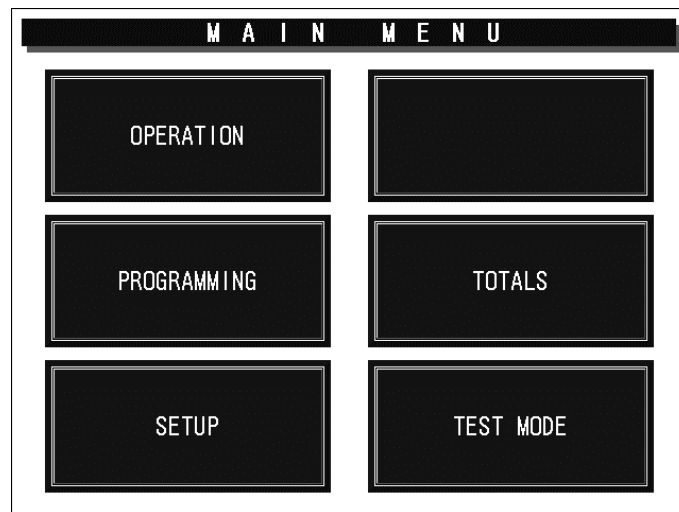

5. The System Menu screen appears.

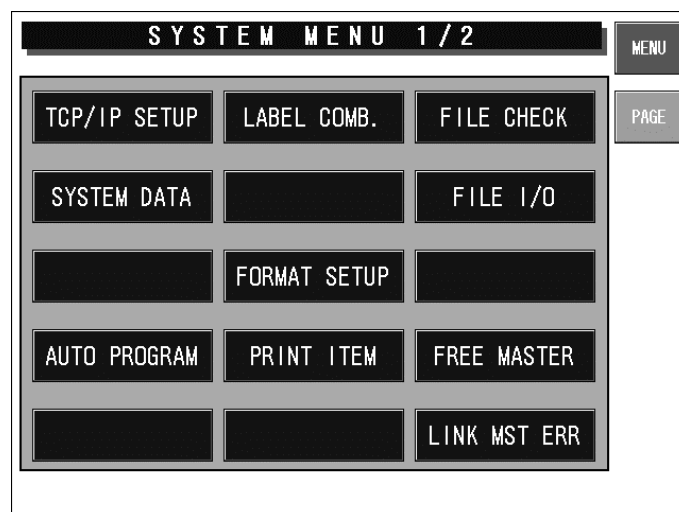

4.2 SYSTEM MENU

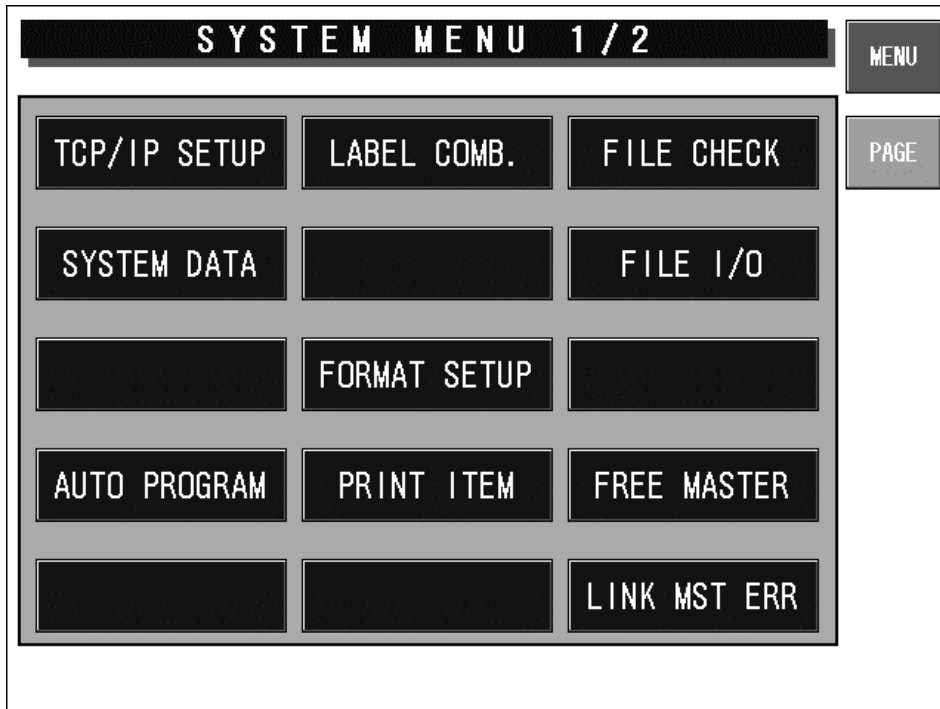

System Menu 1/2 Screen

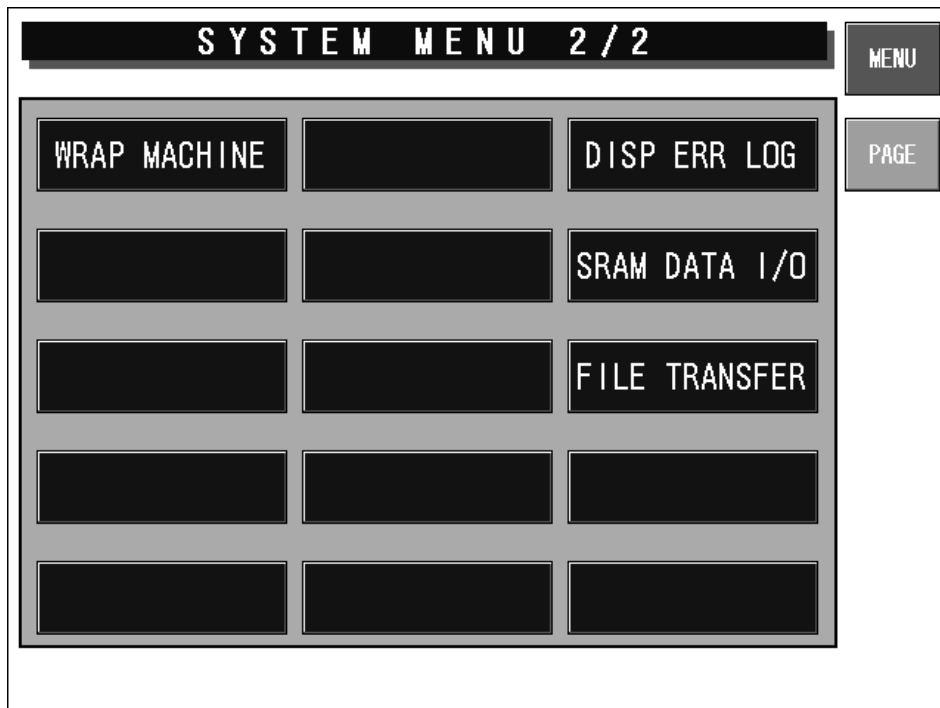

System Menu 2/2 Screen

Buttons/Display Fields	Function
MENU	Changes to the System Menu 1/2 screen.
PAGE	Press to turn over the screen.
TCP/IP Setup	Changes to the TCP/IP Setup screen. Various data can be set according to consultation of your SE when this machine is connected to a computer.
System Data	Changes to the System Data Setup screen. Processing can be selected when the production order is completed. Select master file change (each PLU/unit price).
Auto Program	Changes to the Auto Program Setting screen. Select whether or not to update data and reflect it to the PLU master file automatically for each item.
Label Combination	Changes to the Label Print Combination Set screen. Set the label type, format, and details. Changing to the label details setting and the format edit screen is also possible as an extended screen. This is not displayed when no printer is connected.
Format Setup	Changes to the Format Setup screen. Create, edit, and delete the label formats.
Print Items	Changes to the Print Item Setting screen. Set the label print items and print position.
File Check	Changes to the File Check screen. Initialize all internal master files.
File I/O	Changes to the File I/O screen. Perform master file I/O processing with the IF-21FD.
Free Master	Changes to the Free Message Name Registration screen. Set the free master names 1-5.
Link Master Error	Changes to the Link Master Error Setup screen. Set the error processing when the character string master file linked with a PLU is not registered.
Wrap Machine	Changes to the Wrapper Setting screen. Set various conditions for wrapping tray.
Display Error Log	Changes to the Display Error Log screen. Check past error history (500 or less).
SRAM Data I/O	Changes to the SRAM Data Input/Output screen. Set IF-21FD and the SRAM data I/O.
File Transfer	Changes to the File Transfer Menu screen. Perform CF card and SRAM data input and output.

4.3 TCP/IP SETUP

When this machine is connected to a computer, set the required data according to your SE's advice.

T C P / I P S E T U P	
HOST IP ADDRESS	192. 168. 1. 10
HOST NAME	pink
TARGET IP ADDRESS	192. 168. 1. 11
SUBNET MASK	255. 255. 255. 0
GATEWAY ADDRESS	
TARGET NAME	lsr2k1
USER NAME	target
PASSWORD	user
RCV HOLDER	SendHOLDER

A

B

C

D

E

F

G

H

I

J

K

L

M

N

O

P

Q

R

S

T

U

V

W

X

Y

Z

:

/

_

-

-

MENU

 FIX

 PING

 LOWER LETTER

 .

INPUT

TCP/IP Setup Screen

T C P / I P S E T U P	
T C P / I P S E T U P	
Do you want to confirm TCP/IP setup?	
When [EXECUTE] key is pressed, setting is completed and reboot the scale.	
When [CANCEL] key is pressed, setting is not reflected.	
EXECUTE	CANCEL

A

N

:

/

_

-

-

MENU

 FIX

 PING

 LOWER LETTER

 .

INPUT

Execution Confirmation Screen

Buttons/Display Fields	Function
MENU	Returns to the System Menu 1/2 screen.
FIX	Displays the execution confirmation screen. Press the [EXECUTE] button on the confirmation screen. The machine is automatically turned OFF, and turned ON again to apply parameter table settings.
PING	Executes a communication test with the host computer.
LOWER LETTER/ UPPER LETTER	Selects upper or lower case letters for character entry.
Character buttons (A, B, C, etc.)	Enters characters for setup values.
INPUT	Displays the data input from the numeric keys and/or the character buttons. A total of 15 digits can be displayed. If 15 digits are exceeded, the first characters will be lost.
Parameter Table	Enter new data using the character buttons and/or numerical keys when changing the parameters. Delete a parameter by pressing the corresponding field on the screen without numeric entry to display the confirmation screen and press the [EXECUTE] button on the confirmation screen.
EXECUTE	Executes processing.
CANCEL	Cancels execution.

4.4 SYSTEM DATA SETUP

There are two System Data Setup screens. On these screens, select the basic machine conditions.

SYSTEM DATA SETUP (1)

Order Completion Setup

BUZZER
MESSAGE

PLU Weight Limit Setup

NO
YES

Master Selection (PLU/UP)

POS TYPE POS KIND POS FLAG POS CODE	by PLU	by U/P	LOGO #2	by PLU	by U/P
			LABELING MODE	by PLU	by U/P
REGISTER CODE	by PLU	by U/P	INFEED SPEED	by PLU	by U/P
POP No.	by PLU	by U/P	LOGO #3	by PLU	by U/P
COUPON MESSAGE	by PLU	by U/P	SAFE HANDLING IMAGE NO.	by PLU	by U/P
LOGO #1	by PLU	by U/P		by PLU	by U/P

System Data Setup (1) Screen

SYSTEM DATA SETUP (2)

ROUND TYPE	DOWN	ROUND	UP
BARCODE PRINT	STANDARD	DISCOUNT	
U/P DISCOUNT	NORMAL	SPECIAL	
OCR TYPE	NORMAL	UCC	
DATE CAL	TODAY	TOMORROW	

System Data Setup (2) Screen

Buttons/Display Fields	Function
MENU	Returns to the System Menu 1/2 screen.
PAGE	Turns over screens.
Order Completion Setup	<p>The end process can be selected when the production quantity reaches the set order number.</p> <p>Press the desired button to select either "Buzzer" or "Message."</p> <p>The selected button color will change to blue.</p> <p>Default data: "Buzzer"</p>
PLU Weight Limit Setup	<p>Selects whether to use the upper/lower weight limit check or not when processing a weighing commodity.</p> <p>Press to select the item and the button color will change to blue</p> <p>Default data: "No"</p>
Master Selection (PLU/Unit price)	<p>Press the corresponding button to select "By PLU" or "By Unit Price"</p> <p>The selected button will change to blue.</p> <p>Default data: "By U/P" except POS related data and infeed speed.</p>

4.5 AUTO PROGRAM SETTING

There are three Auto Program Setting screens. On these screens, select whether or not to update data and reflect it to the PLU master file automatically for each item.

AUTO PROGRAM SETTING1 / 3			MENU
UNIT/FIXED PRICE	PACK DATE/TIME	NUTRITION NO.	PAGE
NO YES	NO YES	NO YES	
M PRICE MODE	SHELF LIFE	OPEN PRICE	
NO YES	NO YES	NO YES	
FIXED WEIGHT	USE BY PRINT	FORCED TARE	
NO YES	NO YES	NO YES	
SYMBOL/PCS	BARCODE PRINT	PROP. TARE	
NO YES	NO YES	NO YES	
TARE	BARCODE FORMAT	EXTRA MSG1 No.	
NO YES	NO YES	NO YES	

Auto Program Setting 1/3 Screen

AUTO PROGRAM SETTING2 / 3			MENU
EXTRA MSG2 No.	FREE MSG4 No.	LABEL FORMAT	PAGE
NO YES	NO YES	NO YES	
EXTRA MSG3 No.	FREE MSG5 No.	SECOND LABEL	
NO YES	NO YES	NO YES	
FREE MSG1 No.	POP No.	ITEMCODE	
NO YES	NO YES	NO YES	
FREE MSG2 No.	COUPON No.	UPPER/LOWER LIMIT	
NO YES	NO YES	NO YES	
FREE MSG3 No.	IMAGE No.	SH IMAGE No.	
NO YES	NO YES	NO YES	

Auto Program Setting 2/3 Screen

AUTO PROGRAM SETTING3 / 3			MENU
WRAPPING MODE NO YES	LABELING MODE NO YES		PAGE
IN-FEED/WRAP SPD NO YES			
LABEL ROTATION NO YES			
TRAY VOLUME NO YES			
AUTO DETECTION NO YES			

Auto Program Setting 3/3 Screen

Buttons/Display Fields	Function
MENU	Returns to the System Menu 1/2 screen.
PAGE	Turns over screens.
Automatic Update Select	Whether to reflect the change data in the master file can be selected when the data is changed in the normal mode. "No": The master file is not updated. "Yes": The master file is updated. Pressing the button will select the item. Default data: See the table below.

AUTOMATIC UPDATE ITEMS

Auto Update Item	Update Object Master File	Default
UNIT/FIXED PRICE	Weighing mode, Unit price, Fixed price, Unit price number	Yes
M PRICE MODE	Markdown flag, Markdown price	Yes
FIXED WEIGHT	Fixed weight, Weighing mode, Fixed price quantity	Yes
SYMBOL/PCS	Fixed price sign, Fixed price quantity	Yes
TARE	Tare weight	Yes
PACK DATE/TIME	Pack date print flag, Pack time print flag, Pack time selection flag, Pack time	Yes
SHELF LIFE	Shelf life date print flag, Shelf life time print flag, Shelf life period, Shelf life time (relative time)	Yes
USE BY PRINT	Use-by date print selection	Yes
BARCODE PRINT	Barcode print flag	Yes
BARCODE FORMAT	Barcode format	Yes
NUTRITION NO.	Nutrition number	Yes
OPEN PRICE	Open price	Yes
FORCED TARE	Forced tare	Yes
PROP. TARE	Proportional tare	Yes
EXTRA MSG1	Comment No.1	Yes
EXTRA MSG2	Comment No.2	Yes
EXTRA MSG3	Comment No.3	Yes
FREE MSG 1 No.	Free message No.1	Yes
FREE MSG 2 No.	Free message No.2	Yes
FREE MSG 3 No.	Free message No.3	Yes
FREE MSG 4 No.	Free message No.4	Yes
FREE MSG 5 No.	Free message No.5	Yes
ORIGIN No.	Origin number	Yes
POP No.	POP number	Yes
COUPON No.	Coupon number	Yes
IMAGE No.	Image number	Yes
LABEL FORMAT	Label format number	Yes
SECOND LABEL	Second label	Yes
ITEM CODE	PLU code	Yes
UPPER/LOWER LIMIT	Upper weight limit data, Lower weight limit data	Yes
SH IMAGE No.	Safety handling image number	Yes
WRAPPING MODE	Wrapping mode	No
IN-FEED/WRAP SPD	Infeed speed	Yes
LABEL ROTATION	Label pasting direction	Yes
TRAY VOLUME	Piling height	Yes
AUTO DETECTION	Automatic recognition	Yes
LABELING MODE	Wrapping mode	Yes

4.6 LABEL PRINT COMBINATION SETUP

On this Label Print Combination Setup screen, select the label printing configuration, set various conditions for each label, and change the label format.

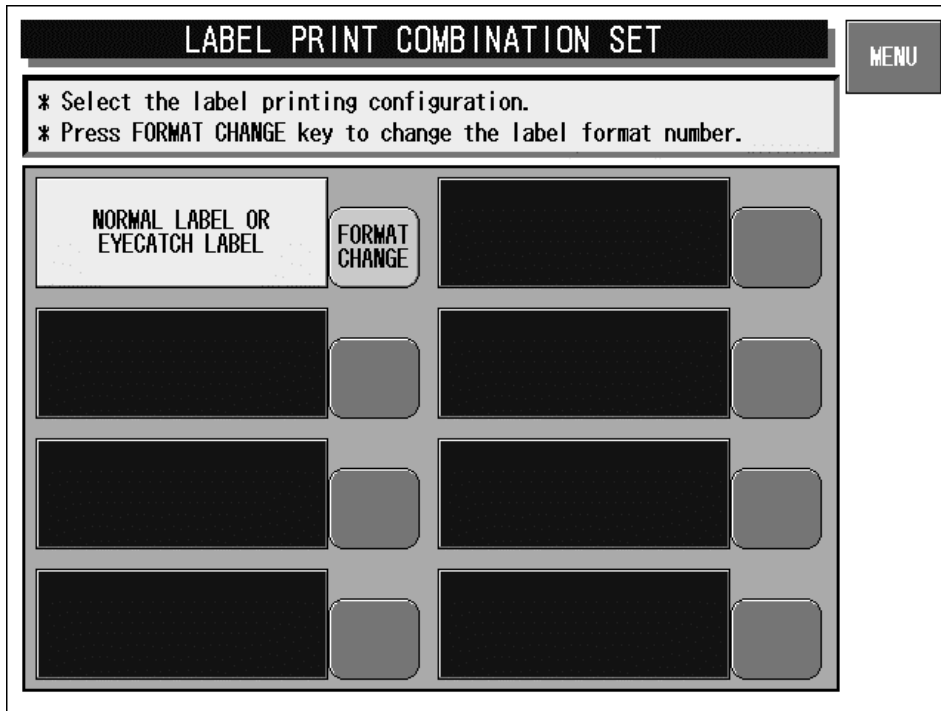

Label Print Combination Setup Screen

Buttons/Display Fields	Function
MENU	Returns to the System Menu 1/2 screen.
FORMAT CHANGE	Changes to the label format number setup screen. The format change button becomes effective only for below-mentioned label print combination.
Label Print Combination	The currently set label print combination is displayed in yellow. Pressing the button that agrees with the label combination will display the confirmation dialog screen of the label print pattern. The print pattern is fixed by pressing the [EXECUTE] button and the display returns to the System Menu 1/2 screen. When the [CANCEL] button is pressed. The print pattern is not fixed and the display returns to the Label Print Combination Setup screen.

4.6.1 CONNECTED PRINTER / PATTERN SELECTION ITEMS

Pattern Selection Item	Main printer only	Two printers	Main printer and Sub (PP)	Two printers and Sub (PP)
Normal label only	●			
Normal label or eye-catching label		●	●	
Normal label or mini eye-catching label	●			
Normal label and sub-label		●	●	
Normal label and batch raw material label		●		
Normal label or eye-catching label and sub-label				●
Normal label or mini eye-catching label and sub-label		●	●	
Normal label or eye-catching label and batch raw material label				●
Normal label or mini eye-catching label and batch raw material label		●		

4.6.2 LABEL PRINT COMBINATION SETUP (FORMAT NO.)

LABEL PRINT COMB. SETUP (FMT No.)				
* Select the label format number and printing setup. * Press FRONT LABEL to set in PLU Master.				
LABEL TYPE	PRINTER	FORMAT No	LABEL PRINT	
NORMAL LABEL	PRINTER 1	52	YES	NO
			YES	NO
			YES	NO
			YES	NO
			YES	NO
			YES	NO
			YES	NO
			YES	NO

LABEL GROUP

FRONT LABEL

BOTTOM LABEL

SUB LABEL

TOTAL LABEL

- PRINTER CHANGE
- LABEL ADDITION
- LABEL CONDITION
- LABEL INFORM

↓
PRESS [DETAIL] KEY

FORMAT FOR FEED
(PRN BLUE TEXT)

↓
PRESS [PRINT]

INPUT

MENU

BACK

CANCEL

FORMAT

DETAIL

FRONT LABEL

Label Print Combination Setup (Format No.) Screen: Front Label

LABEL PRINT COMB. SETUP (FMT No.)				
* Select the label format number and printing setup. * Press FRONT LABEL to set in PLU Master.				
LABEL TYPE	PRINTER	FORMAT No	LABEL PRINT	
BARCODE LABEL	PRINTER 1	52	YES	NO
INGREDIENTS ONLY LABEL	PRINTER 1	61	YES	NO
INGREDIENTS BARCODE LABEL	PRINTER 1	62	YES	NO
			YES	NO
			YES	NO
			YES	NO
			YES	NO
			YES	NO

LABEL GROUP

FRONT LABEL

BOTTOM LABEL

SUB LABEL

TOTAL LABEL

- PRINTER CHANGE
- LABEL ADDITION
- LABEL CONDITION
- LABEL INFORM

↓
PRESS [DETAIL] KEY

FORMAT FOR FEED
(PRN BLUE TEXT)

↓
PRESS [PRINT]

INPUT

MENU

BACK

CANCEL

FORMAT

DETAIL

FRONT LABEL

Label Print Combination Setup (Format No.) Screen: Bottom Label

LABEL PRINT COMB. SETUP (FMT No.)				
* Select the label format number and printing setup. * Press FRONT LABEL to set in PLU Master.				
LABEL TYPE	PRINTER	FORMAT No	LABEL PRINT	
			YES	NO
			YES	NO
			YES	NO
			YES	NO
			YES	NO
			YES	NO
			YES	NO

LABEL GROUP

FRONT LABEL

BOTTOM LABEL

SUB LABEL

TOTAL LABEL

- PRINTER CHANGE
- LABEL ADDITION
- LABEL CONDITION
- LABEL INFORM

↓
PRESS [DETAIL] KEY

FORMAT FOR FEED
(PRN BLUE TEXT)

↓
PRESS [PRINT]

INPUT

MENU

BACK

CANCEL

FORMAT

DETAIL

FRONT LABEL

Label Print Combination Setup (Format No.) Screen: Sub-label

LABEL PRINT COMB. SETUP (FMT No.)				
* Select the label format number and printing setup. * Press FRONT LABEL to set in PLU Master.				
LABEL TYPE	PRINTER	FORMAT No	LABEL PRINT	
TOTAL/SUBTOTA	PRINTER 1	97	YES	NO
			YES	NO
			YES	NO
			YES	NO
			YES	NO
			YES	NO
			YES	NO

LABEL GROUP

FRONT LABEL

BOTTOM LABEL

SUB LABEL

TOTAL LABEL

- PRINTER CHANGE
- LABEL ADDITION
- LABEL CONDITION
- LABEL INFORM

↓
PRESS [DETAIL] KEY

FORMAT FOR FEED
(PRN BLUE TEXT)

↓
PRESS [PRINT]

INPUT

MENU

BACK

CANCEL

FORMAT

DETAIL

FRONT LABEL

Label Print Combination Setup (Format No.) Screen: Total Label

LABEL PRINT SETUP (FRONT LB)		
<p>* Following information is referred when front label type is set to fixed in PLU file. * The label is printed based on setup data such as printer number, label format and cassette. * In case the label type is set to fixed in PLU file, the label printing configuration will not be referred. * Set the following step 1-3. 1. Set the printer number to print the front label. 2. Set the label format number to print the front label. (Press FORMAT key to edit the label format) 3. Set the cassette number if the printer is set with cassette.</p>		
PRINTER	FORMAT No.	CASSETTE No
PRINTER 1	52	1

INPUT

Label Print Setup (Front Label) Screen

LABEL PRINT COMBINATION SETUP						
Label Printing Setup						
LABEL TYPE	PRINTER	FORMAT	CASS	LABEL PRINT		LB PRINT CONDITION
NORMAL LABEL	PRINTER 1	52	1	YES	NO	NO CONDITION
EYECATCH IMAGE LABEL	PRINTER 1	23	1	YES	NO	W/Eyecatch image
EYECATCH PRICE LABEL	PRINTER 1	28	1	YES	NO	W/Campaign price
CAMPAIGN COMMENT LABEL	PRINTER 1	0	1	YES	NO	W/Campaign comment
CAMPAIGN ORIGIN LABEL	PRINTER 1	0	1	YES	NO	W/Campaign origin
BARCODE LABEL	PRINTER 1	52	1	YES	NO	B LB: barcode

* Press [LABEL DETAIL] key for further setup for label print.
 * Press [INITIALIZATION] key to return to the DEFAULT setting.

*Unable change bottom label's print conditions.

INPUT

Label Print Combination Setup Screen

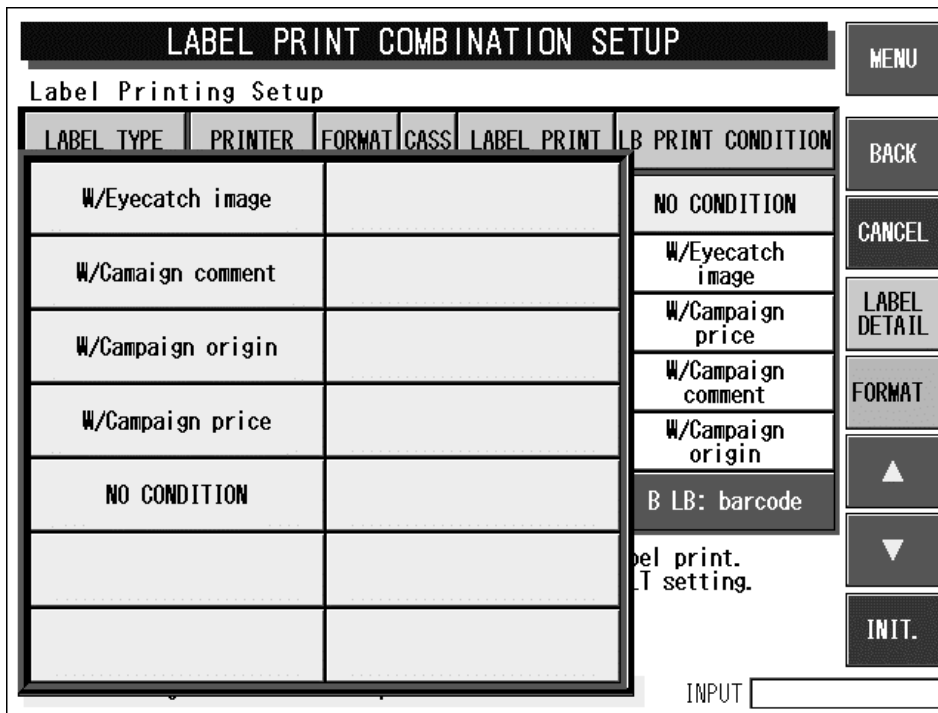

Label Print Condition Pop-up Screen

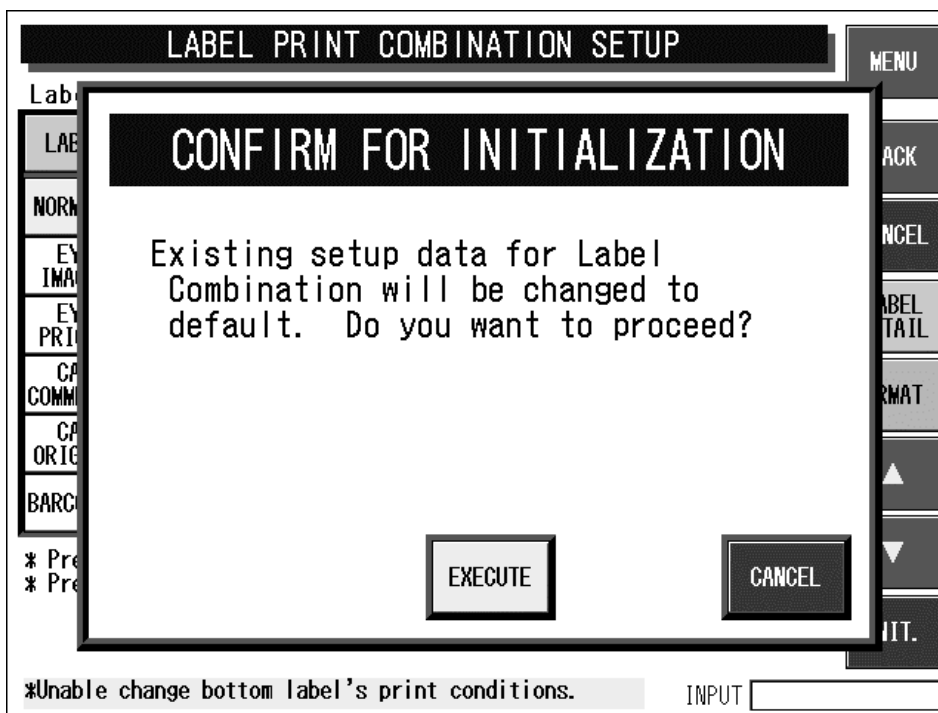

Execution Confirmation Screen

Buttons/Display Fields	Function
MENU	Returns to System Menu 1/2 screen.
BACK	Saves data changes and returns to the Label Print Combination Setup screen.
CANCEL	Cancels data changes and returns to the Label Print Combination Setup screen.
FORMAT	Pressing without numeric entry changes to the format edit screen for the format number of the selected label type. Pressing after numeric entry changes to the format edit screen for the entered number.
DETAIL	Changes to the Print Combination Detail Setup screen. <ul style="list-style-type: none"> • Printer selection • Print item addition • Format number setting • Print condition setting • Label print detail information setting • Label type addition
FRONT LABEL	Changes to the printer, format number, and cassette number setup screen for a label to be attached on the tray top.
INITIALIZE	Returns the print combination data to the default data.
▼ ▲	Moves the cursor up or down.
LABEL DETAIL	Change to the label detail setup data (print density, sensor distance, etc.). The current label format number displayed on the label detail setup screen becomes the format number at the present cursor position (highlighted yellow).
Label Type	Displays the printer name for each label type. Press the label type field to enable the current label selection. Edit the format number of the selected label type after selection by pressing the [FORMAT] button.
Printer	Select the printer (number) that will be used to print the labels. Press to display the pop-up screen. Select the printer on the pop-up screen.
Format No.	Displays the set format number for each label variation. The default format number is displayed at the initial setting. Press the display field after entering a format number to set the number. The format number is automatically set as the default printer format for the specified format number. When two or more format numbers are set to one printer, the higher-ranked format number will be enabled.
Label Print	Select label printing. “Yes”: Labels will be printed. “No”: Labels will not be printed. In this case, the item will not be displayed on the Format Setup screen the next time it is displayed. The selected data will become invalid for total labels.
Label Group	Press the desired button to display the label type items of the selected group and change the color to blue.
Label Print Condition	Set the label print condition. The priority level when a number of print conditions agree is fixed in the order that is displayed on the pop-up screen (from top left to bottom right of the screen). Press to display the pop-up screen.

4.6.3 LABEL DETAIL SETUP

L A B E L S E T U P			
1. Select PRINT No. and set the label No. 2. Set the detail data of the label No. *Up to 99 labels can be registered. Any one can link to printer. *Print check format No. is used only for test printing.			
PRINTER No.	No. 1	CASSET No.	01
		LABEL No.	01
THERMAL PAPER TP.	1:STANDARD LA	SENSOR TYPE	1:LABEL
LABEL GAP	2.5 mm	SENSOR DISTANCE	41.0 mm
PREPRINT FEED	7.5 mm	PRINTING SPEED	2:100 mm/sec
FEED END LEN	3.5 mm	PRINTING DENSITY	5
PRINT DIRECTION	NORMAL REVERSE	2 CLR PRINT DENS.	5 5
BACK FEED	NO YES		
Print Check	Format Info.	Print Check PLU	Cassette No 01
FORMAT No.	Label Wid Label Len	ITEM No.	INPUT
52	60.0 mm 37.0 mm	00000	

Label Print Pattern (Label Details) Setup Screen

Buttons/Display Fields	Function
BACK	Save data changes and return to the label print pattern detail setup screen.
Printer No.	Press after numeric entry to display the label information of the entered printer and enable label information change and confirmation (test print). Printer numbers are defined as follows: Printer #1: Main printer 1 Printer #2: Main printer 2 Printer #3: PP printer (and Sub printer)
Cassette No.	Press after numeric entry to display the label information of the entered cassette and enable label information change and confirmation (test print). The data range is 1-7. An error screen is displayed if the corresponding cassette is not inserted. The cassette number becomes "1" when a non-applicable printer is called.
Label No.	This is used when label print information is different for each printer and cassette. Press after numeric entry to call the label print information. The data range is 1-99. The same default number is set for each printer and cassette. This data is not usually changed. The label sensor distance is associated with the label number. For example, if the same number is set for printers #1 and #3, the label sensor distance will be the same for both printers and will result in a misalignment.
Thermal Paper Type	Set label type. Press one of these buttons after numeric entry to set the paper type. Press one of these buttons without numeric entry to display the pop-up screen. Next, press the desired button to set the paper type.

Buttons/Display Fields	Function
Label Gap	Set label gap. Press after numeric entry to set the gap length. The data range is 0-999 (0.0 mm – 99.9 mm on the screen). Default data: 2.0 mm
Preprint Feed	Set the preprint feed length. Press after numeric entry to set the feed length. The data range is 0-999 (0.0 mm – 99.9 mm on the screen). Default data: 7.5 mm
Feed End Length	Displays the set feed end length (unit: mm). Press after numeric entry to set the feed end length. The data range is 1-999 (0.1 mm – 99.9 mm on the screen). Default data: 3.0 mm The label is issued leaving the set length behind and fed immediately before the label is sucked.
Print Direction	“Normal rotation” and “Reverse rotation” can be set as the label print direction. The selected item will change color to blue. Default data: “Normal rotation”
Back Feed	Select the back feed availability at the start of label printing. The selected item will change its color to blue. Default data: “Yes” When “Yes” is selected the label is back fed in the above-mentioned preprint feed length and printing starts. Make sure “Yes” is selected at all times.
Sensor Type	Set the label feed availability using the label sensor control. Press after numeric entry to set the sensor type. Press without numeric entry to display the pop-up screen. Press the desired button to make a selection. Default data: “1” (Label sensor)
Sensor Distance	Set the distance between the label sensor position and the printer head end. Press after numeric entry to set the distance. The data range is 0-999 (0.0 mm – 99.9 mm on the screen). Default data: 17.5 mm The label feed amount will increase when the data is increased, and decrease when the data is decreased.
Printing Speed	Set the label print speed. Enter either “1” or “2” (1: 80mm/sec 2: 100mm/sec) and press this button. Press without numeric entry to display the pop-up screen. Press the desired button to make a selection. Default data: “2” (100 mm/sec)
Printing Density (0 - 9)	Set the print density when using the monochrome thermal head. Press after numeric entry to set the density. The data range is 0-9. (0: lightest 9: darkest) Default data: “5”
2 Color Print Density (0 - 9)	Set the print density for black and red when the two color thermal head is used. Press one of these buttons after numeric entry to set the density. The data range is 0-9. (0: lightest 9: darkest) Default data: “5” for both black and red
Print Check Format No.	Set the test print format. Press after numeric entry to set the number. The data range is 1-99. Default data: 52 (37 x 60 mm) for printers #1, #3, and #4 20 (55 x 60 mm) for printer #2
Format Information	Displays the label size of the set default format number. Confirm that the set format number is correct. This function is display only and the data cannot be changed.

Buttons/Display Fields	Function
Item No.	Set the test item number for print confirmation. Press after numeric entry to set the number. The checker pattern is printed when the item number is "0."
Cassette No.	This is effective only when the cassette applicable printer number is selected. Displays the number of the inserted cassette. "1" is displayed when the cassette non-applicable printer is used. Make sure the cassette number called is same as the inserted cassette number. An error screen will appear if it is different. This function is display only and the data cannot be changed.

4.7 FORMAT SETTING

With this machine, a maximum of 99 label formats can be set from “1” to “99”.
A maximum of 63 items can be printed in one format that is called as “unit”.

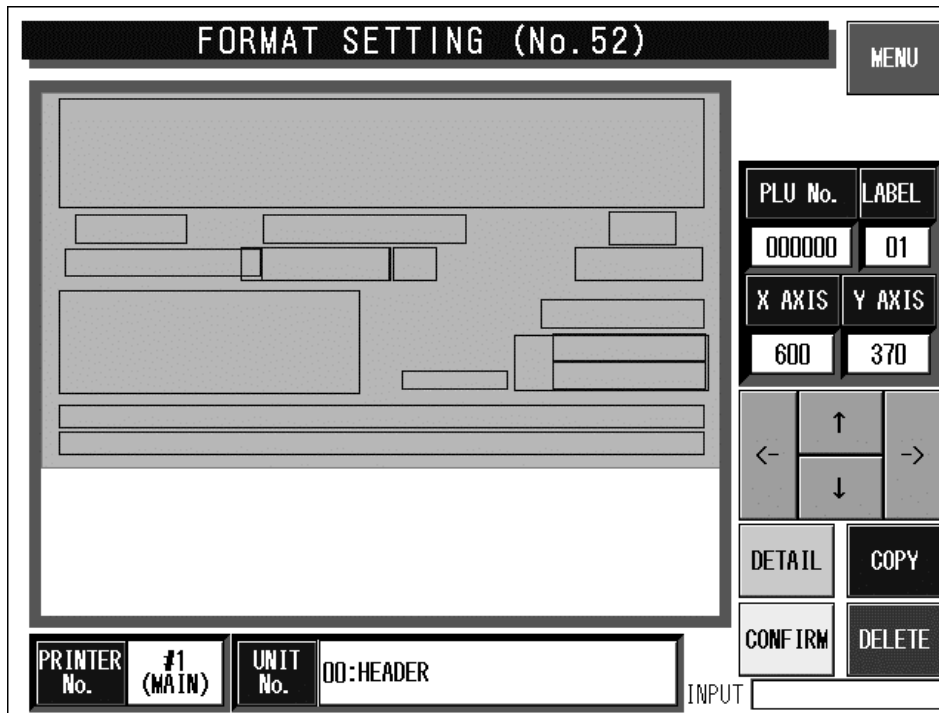

Format Setting Screen

Buttons/Display Fields	Function
MENU	Displays the copy confirmation screen to finish settings.
[←] [↑] [→] [↓]	Moves the selected unit position. “X “ and “Y” axis coordinates change accordingly.
Unit No.	Displays the called unit. Enter the numeric value and press this field to call up the desired unit.
DETAIL	Checks the detailed data for the selected unit,
CONFIRM	Confirms that the change has been made on the screen. Returns to the Format Setting screen.
COPY	Specifies the copy source by entering a numeric value.
DELETE	Deletes the called screen data.

4.8 PRINT ITEM SETTING

On this Print Item Setting screen, select the setting for each print item.

Print Item Setting Screen

Buttons/Display Fields	Function
MENU	Apply the set data and return to the Setup Menu 1/2 screen.
5 X 7 Print Select	Select one of the print items to be printed in 5 X 7 size. Press the desired button to select the item and change the button color to blue.
M Price Print Select	Select either "Label print price" or "Barcode price" when printing the mark down price label. Select one of the following 3 types: Barcode Only: The markdown price is reflected only in the barcode, and the normal price (before markdown) is printed in the price print field. Barcode and Double line The markdown price is reflected only in the barcode, and two strikeout lines are printed over the normal price (before markdown). Double line and M price: The markdown price is reflected in the barcode and two strikeout lines are printed on the normal price (before markdown) and the price after markdown is printed. Press the desired button to select the type and change the button color to blue. Default data: "Double line and M price" <i>Note: Two strikeout lines and the markdown price are printed for commodities which the markdown price is registered.</i>

Buttons/Display Fields	Function
Comment Print Position Select	<p>Select the comment character string print position when it is included in the PLU name extension field. Select one of the following 4 types:</p> <p>Format: Printed in the position specified by the format. Under: Printed under the PLU name. Under Ingredient: Printed under the ingredient. Over: Printed above the PLU.</p> <p>Press the desired button to select the type and change the button color to blue. Default data: "Format"</p>
Origin Print Position Select	<p>Select the origin name character string print position when it is included in the PLU name extension field. Select one of the following 3 types:</p> <p>Format: Printed in the position specified by the format. Left: Printed on the left of the PLU. Right: Printed on the right of the PLU.</p> <p>Press the desired button to select the type and change the button color to blue. Default data: "Format"</p>
Register Code Print Select	<p>Select the item to be printed in the register code print field. Select either "Register" or "Store No." Press the desired button to select the type and change the button color to blue. Default data: "Register"</p>
Repack Mark Print Select	<p>Select the printing of "." and the Use-by date on the end of each pack. Select either "No Print" or "Print." Press the desired button to select the type and change the button color to blue. Default data: "Print"</p>
Register Code Print Position Select	<p>Select register code print position when it is included in the PLU name extension field. Select one of the following 3 types:</p> <p>Format: It is printed at the position specified by the format. Left: It is printed on the left of the PLU name. Right: It is printed on the right of the PLU name.</p> <p>Press the desired button to select the type and change the button color to blue. Default data: "Format"</p>
POP Print Position Select	<p>Select POP character string print position when it is included in the PLU name extension field. Select one of the following 3 types:</p> <p>Format: Printed at the position specified by the format. Left: Printed on the left of the PLU name. Right: Printed on the right of the PLU name.</p> <p>Press the desired button to select the type and change the button color to blue. Default data: "Format"</p>

4.9 FILE CHECK

This screen is used to confirm master files such as PLU master, Store master, Extra message master files, etc. registered in this machine.

FILE CHECK			Memory Information	
No.	MASTER NAME	NUMBER	REMAINING (BYTE)	PLU MASTER (NUMBER)
1	PLU /UNIT PRICE FILE [WILL BE CLEARED]	583 (583)	1823200	7725
2	STORE FILE [WILL BE CLEARED]	2		
3	EXTRA MESSAGE 1 [WILL BE CLEARED]	3		
4	POP MESSAGE FILE [WILL BE CLEARED]	0		
5	COUPON MESSAGE FILE [WILL BE CLEARED]	0		
6	ORIGIN FILE [WILL BE CLEARED]	0		
7	EXTRA MSG 2 [WILL BE CLEARED]	0		
8	EXTRA MSG 3 [WILL BE CLEARED]	0		

*Press [SELECT] to select Master for initialization..

Buttons: MENU, ▲, ▲, ▼, ▼, SELECT, SELECT ALL, EXECUTE

Memory Information: 100%, 50%, 0%

File Check Screen

Buttons/Display Fields	Function
MENU	Returns to the System Menu 1/2 screen.
Master Name	Displays master names (only master files that can be processed by the IF-21FD and master files with the number "0"). Press the desired field to make a selection and change the color to light blue.
Number	Displays the number of data registered in the machine (only master files that can be processed by the IF-21FD and master files with the number "0"). Press the desired field to make a selection and reverse the color to light blue.
Memory Information	Displays remaining SRAM memory in bytes. (Zero suppression, Max.8 digits)
PLU Master	Calculates the number of items that can be registered based on the amount of remaining memory. Number of Items = Remaining amount ÷ (Fixed PLU master parts + PLU name character string 128 bytes + One unit price master)
Memory Remaining Display Bar	Displays the amount of memory remaining in black.
▼ ▲	Press to move the master information list display page up/down.
▼ ▲	Press to move the cursor position in the master information list display up/down (cursor is yellow).

Buttons/Display Fields	Function
SELECT	<p>Select master files for initialization. Press the desired field where the cursor is positioned to select a master file. This will select an unselected field or unselect a selected field. Selecting a field will change the field where the cursor is positioned light blue. Placing the cursor on a selected item will change the color of the field to green.</p>
SELECT ALL	<p>Select or cancel all master files for initialization. All items on the list will be selected even if there is only one unselected item on the list. When all items are already selected, they will be canceled. Selecting will change the color of the entire field to light blue.</p>
EXECUTE	<p>Press to initialize the selected master files. Processing is different for each master file.</p> <ul style="list-style-type: none"> • Clear: Delete existing master files. • Initialize: Existing master files will be deleted and initialized to default values. • Number reference: Confirm the number of existing master files without execution.

Note: Processing guidance is displayed at the bottom of the screen.

4.10 FILE INPUT/OUTPUT

Master files stored in this machine can be input and output to or from a floppy disk via IF21 or to the CF card via DataRapid. Note that the PLU master data must be downloaded first when downloading PLU and Unit price master data individually to the main body.

Note: Connect the IF-21FD with the I2NET INLINE (Dsub-9).

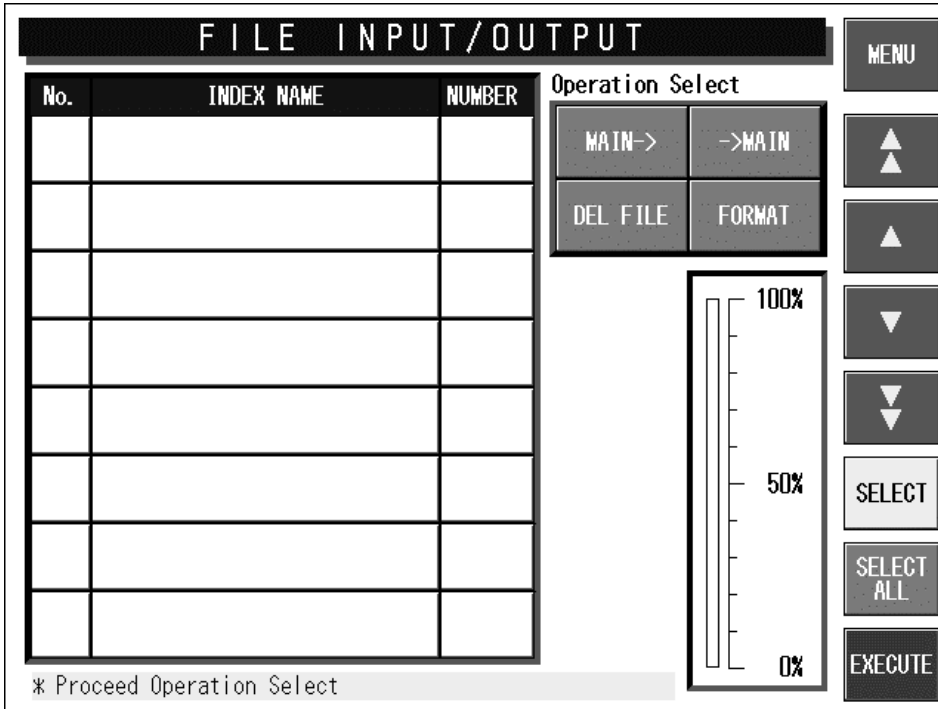

File Input/Output Screen

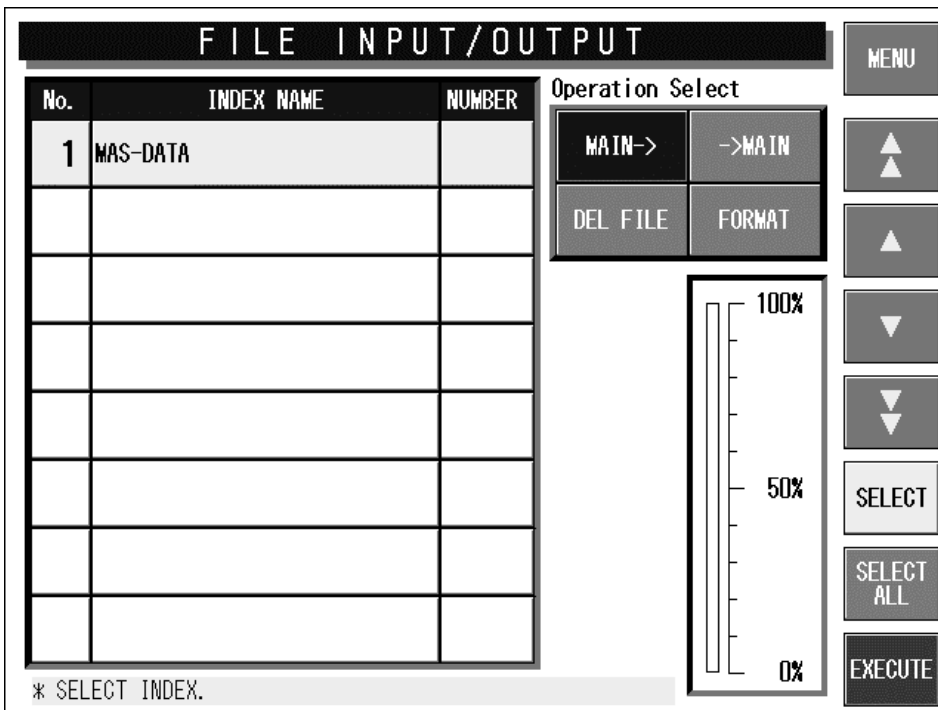

File I/O Index Screen

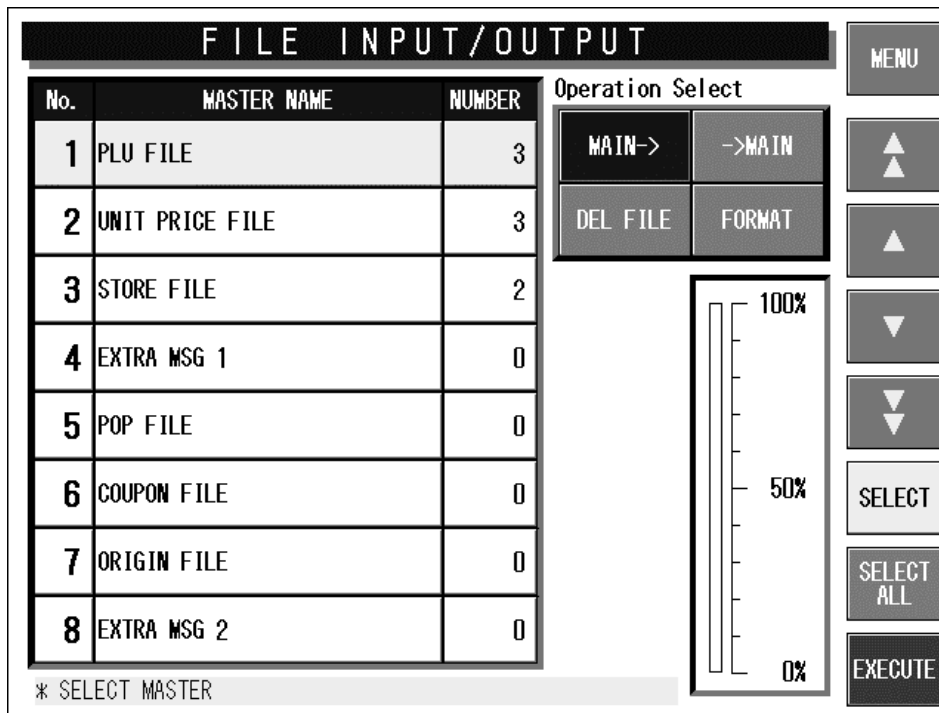

File I/O Master Display Screen

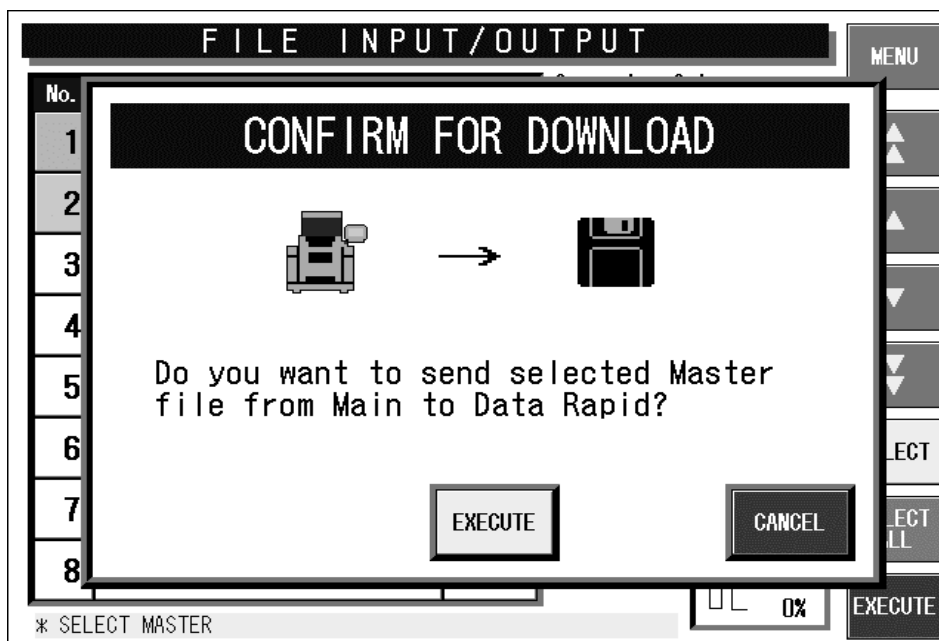

Download Confirmation Screen (Main body → IF21FD)

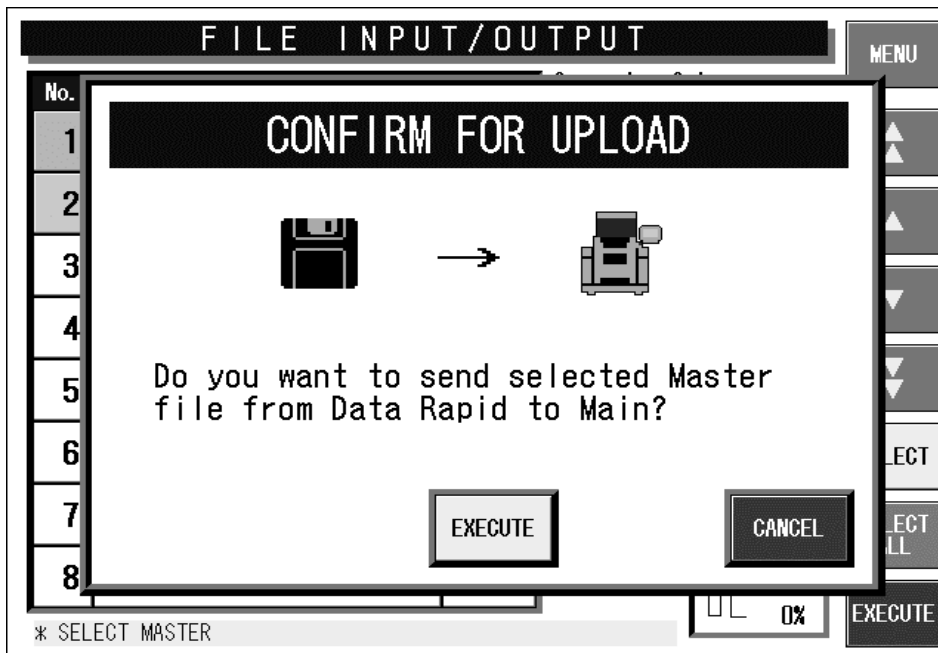

Upload Confirmation Screen (IF21FD → Main body)

Buttons/Display Fields	Function
MENU	Returns to the System Menu 1/2 screen.
Operation Select	Select file I/O processing. Select "Main body →" "→ Main body" "File delete" or "Format". Press the button to request the index information acquisition from the IF-21FD and change to the index screen. Press it again to re-display the index screen.
Bar Graph	Shows the processing progress of each master file.
▼ ▲	Press to move the master information list display page up/down.
▼ ▲	Press to move the cursor position (highlighted yellow) in the master information list display up/down. Only existing index columns can be moved when "→Main body" or "File Delete" is selected.
Index Information	Displays the index numbers and names of files in the IF-21FD. Processing differs according to the processing item selected. Main body→: Changes to the master display screen when the index is selected via the index name edit screen. →Main body: Changes to the master display screen when the index is selected via the index name edit screen. However, it is only possible to select an item displayed in the index list. File Delete: The selected index is displayed in light blue when the indexes are selected. Format: This screen is used solely for confirmation files existing in the IF-21FD and selection is not possible.

Buttons/Display Fields	Function
Master Information	<p>Processing is different according to the selected processing item. The selected field color will reverse light blue.</p> <p>Main body →: The names and counts of existing master group existing in own machine can be listed on the screen. Pressing the field button will perform selection for non-selected data, and cancellation for selected data.</p> <p>→Main body: From the index file acquired from the IF-21FD, the master file information (names and counts) in the IF-21FD can be listed on the screen. Pressing the field button will perform selection for non-selected data, and cancellation for selected data.</p>
SELECT	<p>Select master files for input/output. Press the desired field where the cursor is positioned to select a master file. This will select an unselected field or unselect a selected field. Selecting a field will change the field where the cursor is positioned light blue. Placing the cursor on a selected item will change the color of the field to green.</p>
SELECT ALL	<p>Select or cancel all master files for input/output. All items on the list will be selected even if there is only one unselected item on the list. When all items are already selected, they will be canceled. Selecting will change the color of the entire field to light blue.</p>
EXECUTE	<p>Pressing this button will input or output the selected master data.</p>

Note 1: Connect the IF-21FD with the INLINE (Dsub-9) of I2NET.

2: When downloading PLU and Unit price master data individually to the main body, ensure to download the PLU master data first.

4.11 FREE MESSAGE NAME REGISTRATION

With this machine, master files are prepared at the factory. On this screen, there are five areas named Free 1 through Free 5 you can freely use. You can change these master name as you like.

Note: When a free master name is changed the updated master name is displayed thereafter.

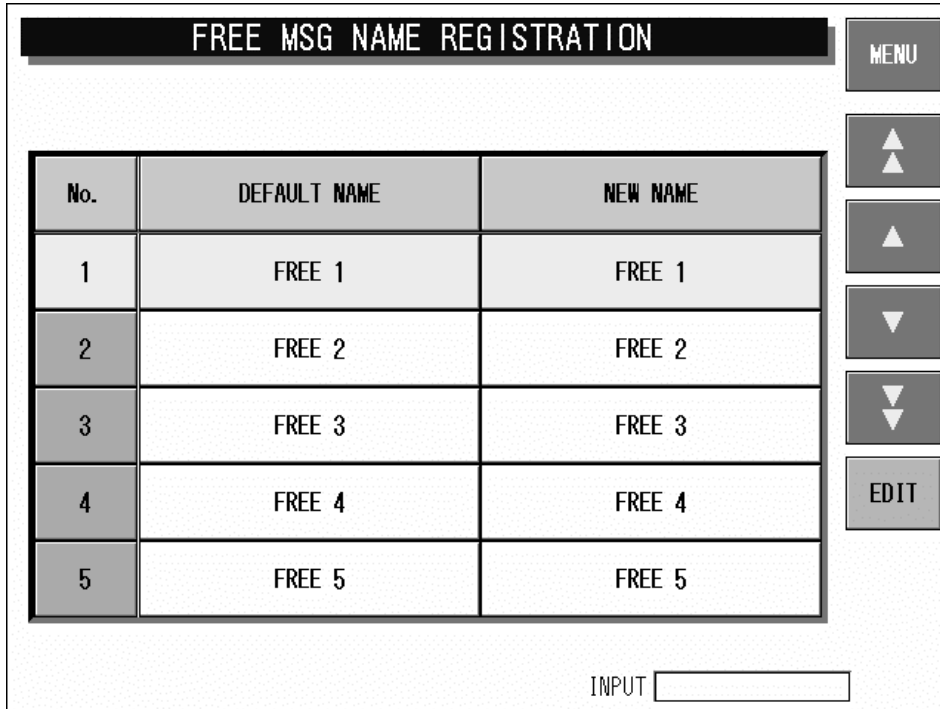

Free Message Name Registration Screen

Buttons/Display Fields	Function
MENU	Returns to the System Menu 1/2 screen.
▼ ▲	Press to move the cursor position (highlighted yellow) up/down.
▼▲ ▼▲	Press to move the cursor position to either Free 1 or Free 5.
EDIT	Press change to the free master name edit screen at the present cursor position.

Note: When the free master name is changed, the updated master name is displayed thereafter.

4.12 LINK MASTER ERROR SETUP

A master data that is linked with the PLU master data is called "Link Master". This "YES" or "No" setting decides whether an error is displayed or not when the PLU master data is called, and the corresponding producer master data is not found.

LINK MASTER ERROR SETUP					
* Set the error control of the unregistered line when Link Master is called.					
* Select YES to display error screen.					
LINK MASTER NAME	ERROR SET		LINK MASTER NAME	ERROR SET	
POP	NO	YES	FREE 1 MASTER	NO	YES
	NO	YES	FREE 2 MASTER	NO	YES
EXTRA MSG 1	NO	YES	FREE 3 MASTER	NO	YES
COUPON MSG	NO	YES	FREE 4 MASTER	NO	YES
EXTRA MSG 2	NO	YES	FREE 5 MASTER	NO	YES
EXTRA MSG 3	NO	YES		NO	YES

Link Master Error Setup Screen

Buttons/Display Fields	Function
MENU	Returns to the System Menu 1/2 screen.
Error Set	Select error screen display for each link master if the character string is not registered when a link master is called. Press either "NO" or "YES" to select and the selected button color will change to blue.

4.13 WRAPPER SETTING

On this screen, perform the required settings and adjust the film conditions.

WRAPPER SETTING 2/2

1. Adjust the brake timing of the right and left film rolls.
 *Set a new film.
 *+ direction: Faster braking.
 *- direction: Slower braking.
 *After setting, press FILM FEED
 to feed the film.
 *Make sure that the film is not caught inside the insertion plate.

BACK

LEFT ROLL STOP POS.

0

+ -

RIGHT ROLL STOP POS

0

+ -

LEFT FILM STOP POS.

5

+ -

RIGHT FILM STOP POS

0

+ -

RETURN

RIGHT FILMSET

RIGHT FILM FD

LEFT FILMSET

LEFT FILM FD

INPUT

Wrapper Setting Screen

Buttons/Display Fields	Function
MENU	Returns to the System Menu 1/2 screen.
Return	Resumes wrapper and applicator operation.
Film Material	Select film material and type. Press to display a pop-up screen. Next, select the desired film type. The heater temperature is set to the default value upon selection.
Heating Time	Set heater temperature. Press the display field after numeric entry to set the heater temperature (°C) and display it in the display field. The data range is 80 - 180 and the default value is determined according to the film material.
Automatic Discharge	Select either "Yes" or "None" for automatic discharge function. Default data: "All trays"
Film Centering Adjustment	Adjust film centering. Press [-] or [+] without numeric entry to adjust film centering in increments of 1 mm. Press [-] or [+] after numeric entry to set the film centering adjustment correction data. The data range is 0 - 99. Default data: 0 mm
Film Length Adjustment	Adjust the film feed length. This procedure is similar to the film centering adjustment procedure.
Film Width Information	Displays film width information (cm). Data setting is not possible.
FILM SET (Right/Left)	Press to start film set operation.
FILM FEED (Right/Left)	Press to start film feeding operation.

4.14 DISPLAY ERROR LOG

With this machine, the display error log can be recorded. To save the error log data to the CF card, press the FILE OUT button. Press to select one of four card types to which the log data is stored. Usually, main program is stored in the CF-1. Therefore, select the card type other than the CF-1.

Note 1: Press the [PRINT] key to print the error log label. (Journal output is performed when the journal printer is connected)

Note 2: Error logs are output in CSV format.

Note 3: The error log can be analyzed by opening spreadsheet software (Excel and Lotus123) or database software (Access).

4.14.1 DISPLAY ERROR LOG SCREEN

DISPLAY ERROR LOG						BACK
DATE	TIME	ERROR No.	PLU No.	TRAY	ERROR DETAIL	
9/30	10:12	0322-0000	000000	0000	Start-point return processing is d	
9/30	10:12	0361-0000	000000	0000	The power supply was switched on	
9/30	09:52	0322-0000	000000	0000	Start-point return processing is d	
9/30	09:52	0361-0000	000000	0000	The power supply was switched on	
9/30	08:55	0322-0000	000000	0000	Start-point return processing is d	
9/30	08:55	0901-1000	000000	0000	It cannot communicate with the pri	
9/30	08:55	0361-0000	000000	0000	The power supply was switched on	
9/30	08:44	0322-0000	000000	0000	Start-point return processing is d	
9/30	08:44	0901-1000	000000	0000	It cannot communicate with the pri	
9/30	08:44	0361-0000	000000	0000	The power supply was switched on	
9/29	18:39	0361-0000	000000	0000	The power supply was switched on	
9/29	17:27	0322-0000	000000	0000	Start-point return processing is d	
9/29	17:26	0361-0000	000000	0000	The power supply was switched on	

▲ ▼ Curr/ALL 1 / 21 DELETE FILE OUT

Display Error Log Screen

Buttons/Display Fields	Function
BACK	Returns to the previous screen.
Date	Press to display the selected items in order.
Time	
Error No.	
PLU No.	
Tray No.	
▼ ▲	Press to change the error list page.
DELETE	Press to initialize the confirmation screen. Press [EXECUTE] to clear the error log information. Press [CANCEL] to close the dialog without deleting data.
FILE OUTPUT	Changes to the error log file output select/execute screen.

Note: When the [PRINT] key is pressed, the error log label print is executed. (When the journal printer is connected, the journal output is performed)

4.14.2 CARD SELECT FOR ERROR LOG FILE OUTPUT

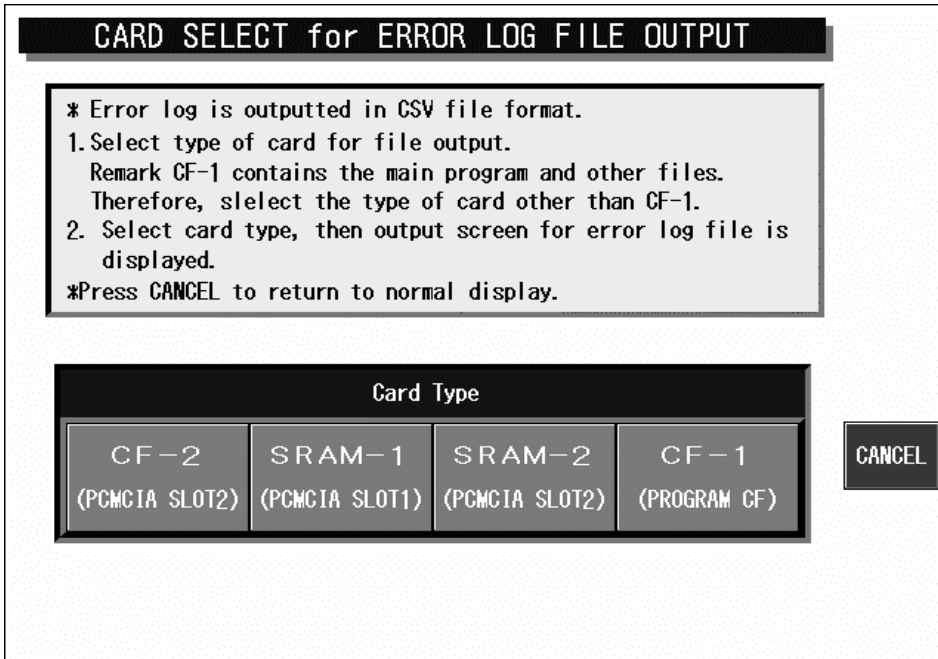

Error Log File Output Screen

Buttons/Display Fields	Function
CANCEL	Pressing this button will not execute the file output, and return to the error log screen.
EXECUTE	Press to output the error log in CSV format to the selected card.
Card Type	Press the corresponding button to select one of the four cards as the error log file output destination. CF-2 / SRAM-1 / SRAM-2 / CF-1 The selected button changes to blue.

Note 1: An error log is output in CSV format.

Note 2: The error log can be analyzed by opening the spread sheet software (Excel and Lotus123, etc.) or the database software (Access etc.).

4.14.3 ERROR LOG FILE OUTPUT PROCEDURE

(1) Select the card type

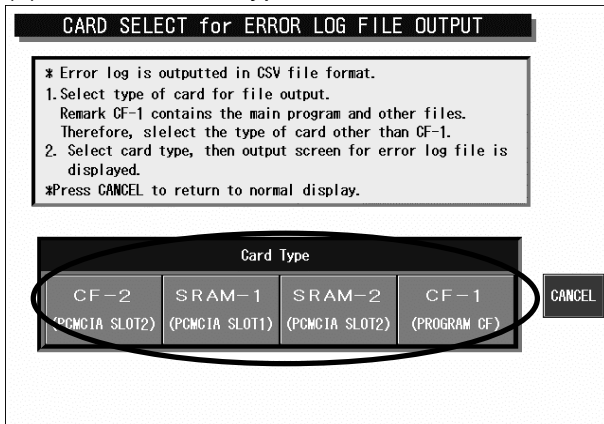

(2) Select the file number.

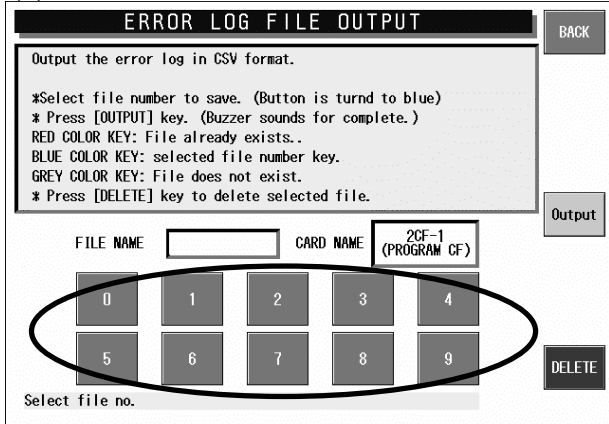

(3) Output the file.

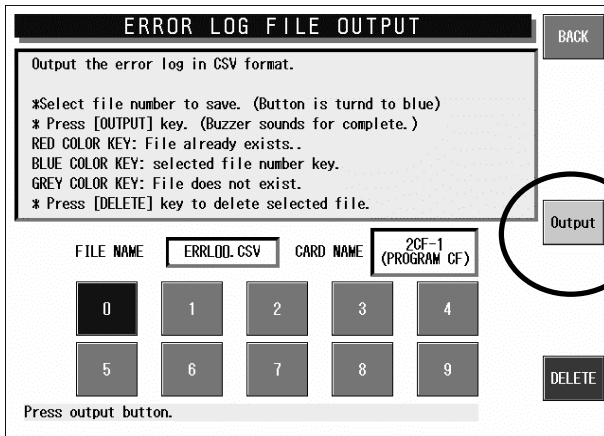

(4) The confirmation screen appears.

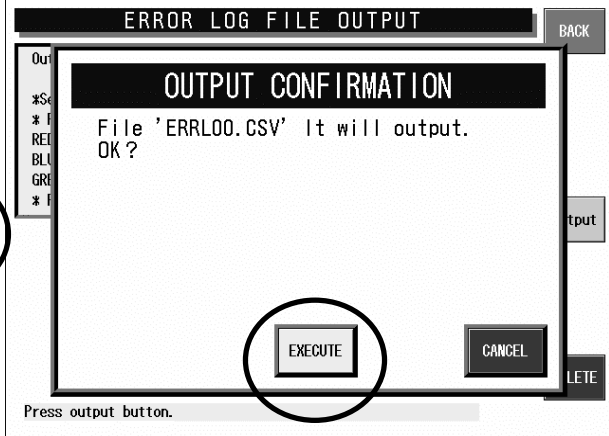

(5) The Display Error Log screen appears.

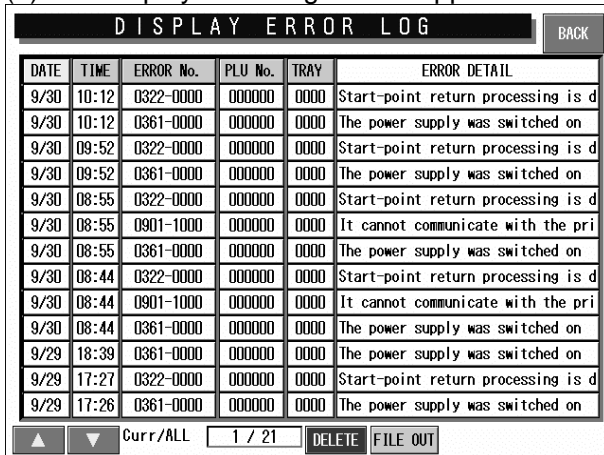

4.14.4 ERROR LOG FILE OUTPUT DELETE PROCEDURE

(1) Select the card type.

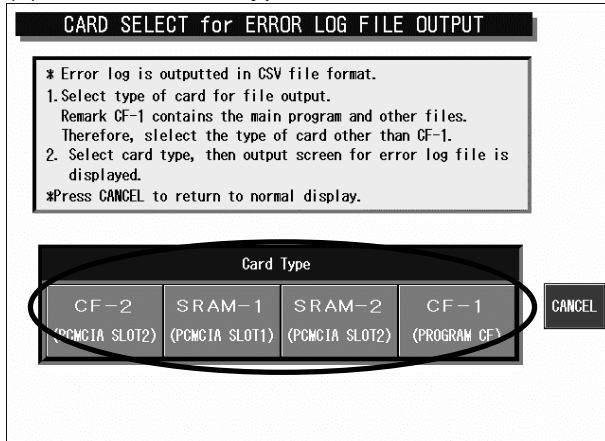

(2) Select the file number.

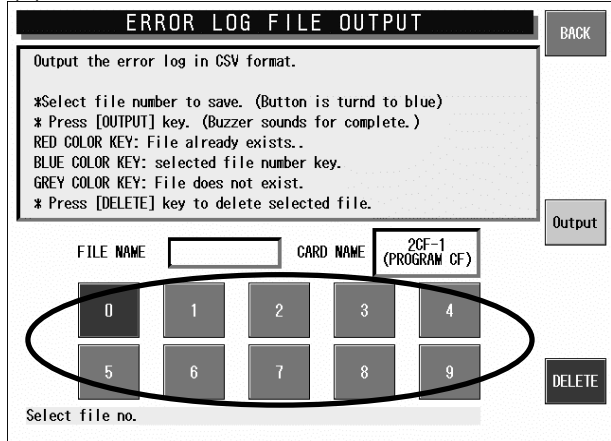

(3) Delete the file.

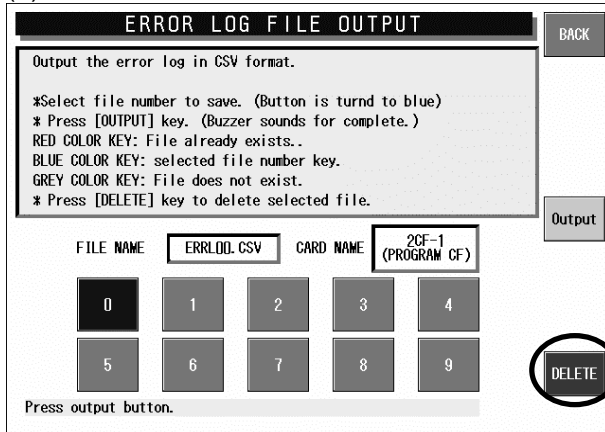

(4) The confirmation screen appears.



(5) The Display Error Log screen appears.

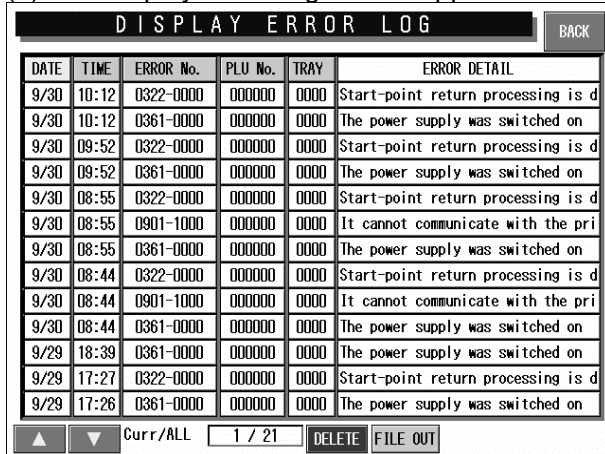

4.15 SRAM DATA INPUT/OUTPUT

This function is used to back up the Static RAM data. The following items are stored in the CF-1 card.

- Items selected in the machine setup screen
- Calendar
- Head run distance
- Wrapping count
- Pasting count
- Wrapper error correction data

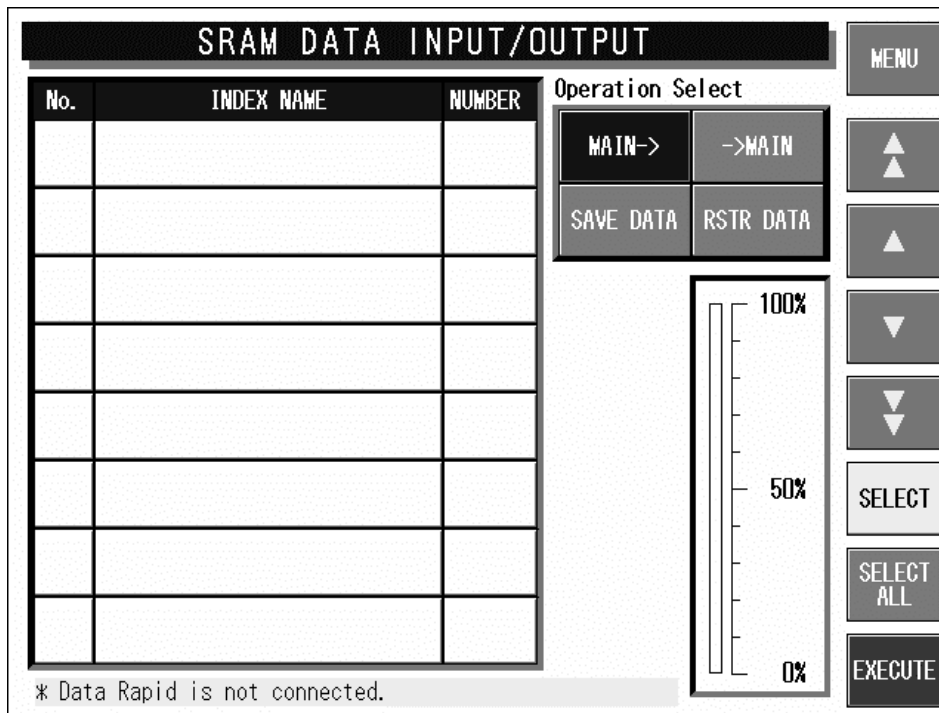

SRAM Data Input/Output Screen

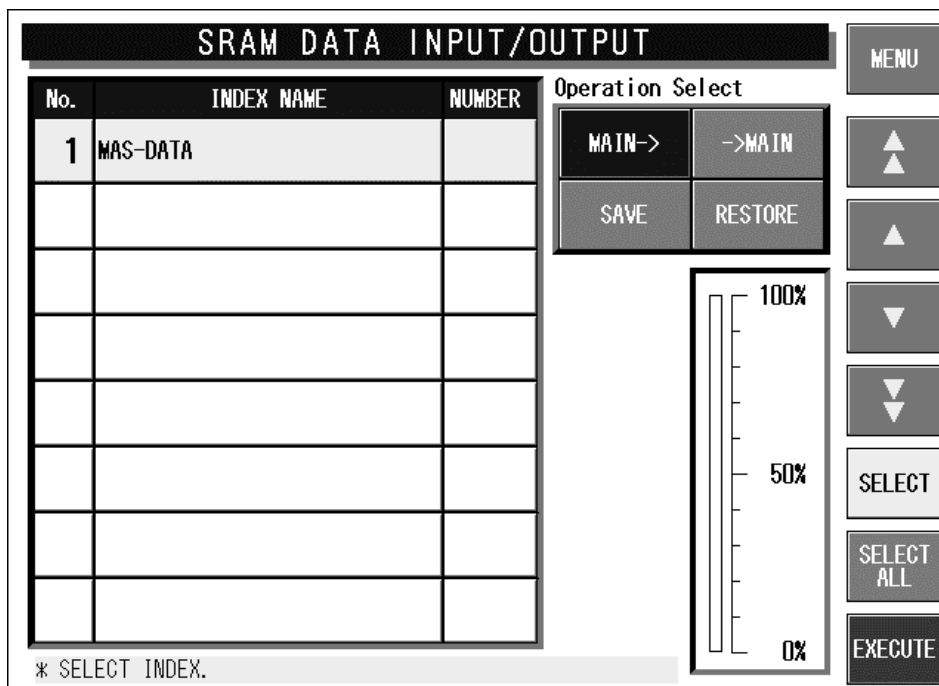

SRAM Data Input/Output (Main body->) Screen

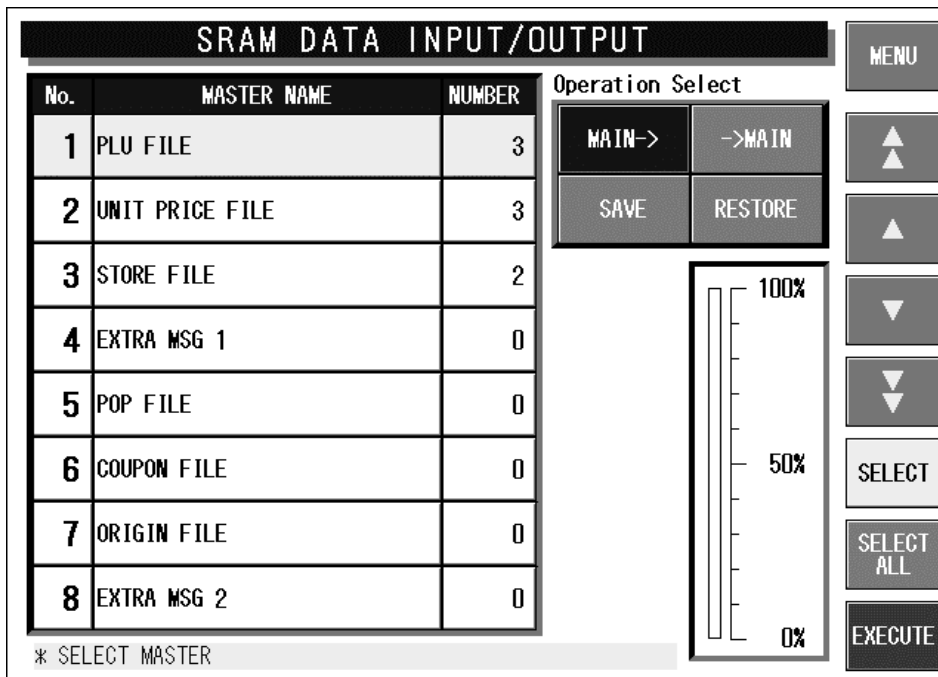

Output Master Data Selection Screen

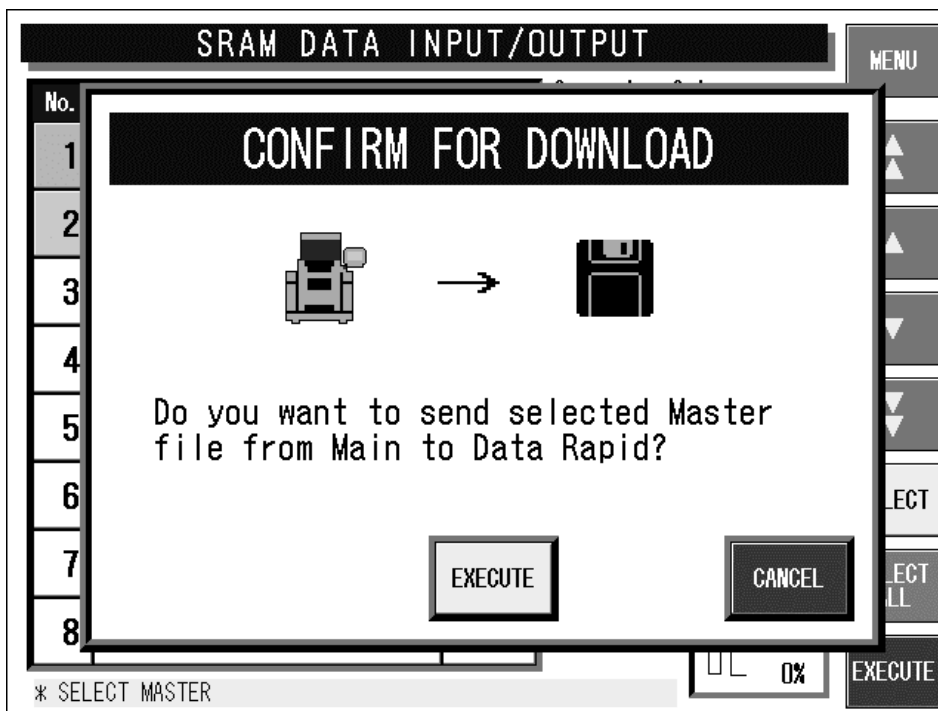

Download Confirmation Screen

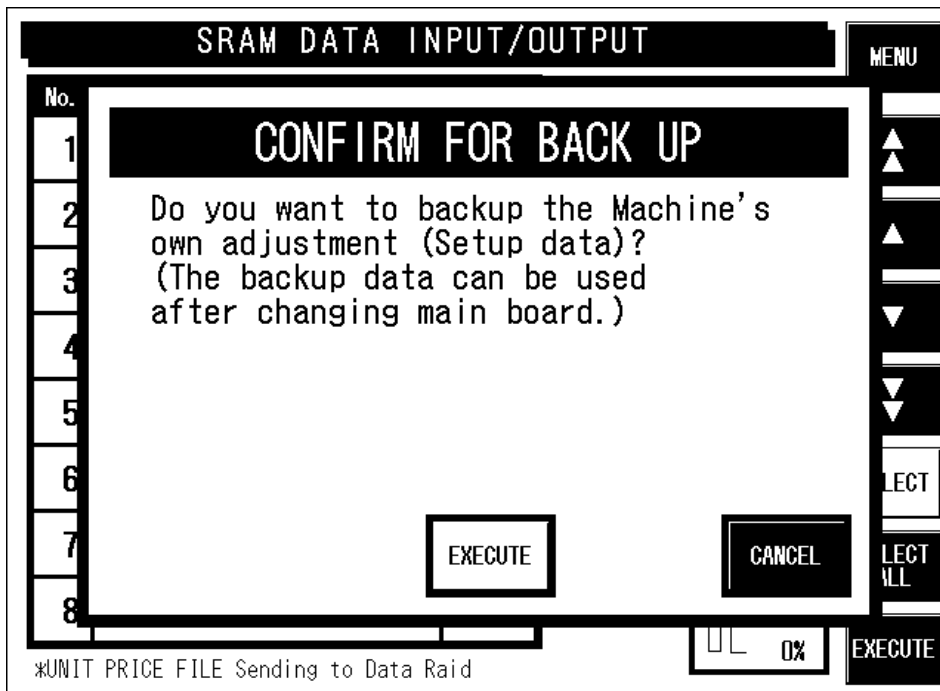

Backup Confirmation Screen

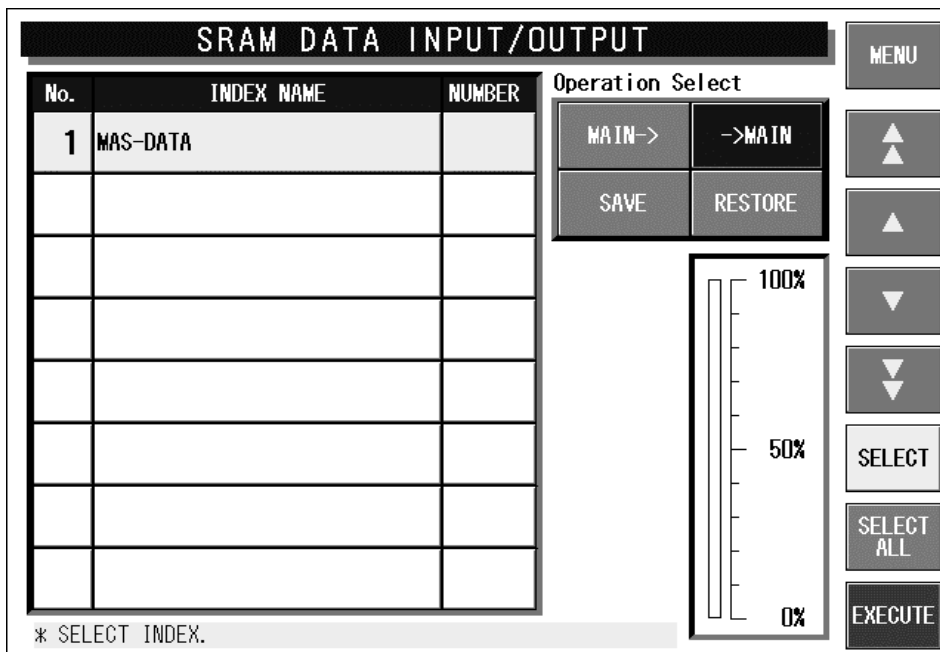

SRAM Data Input/Output (→ Main body) Screen

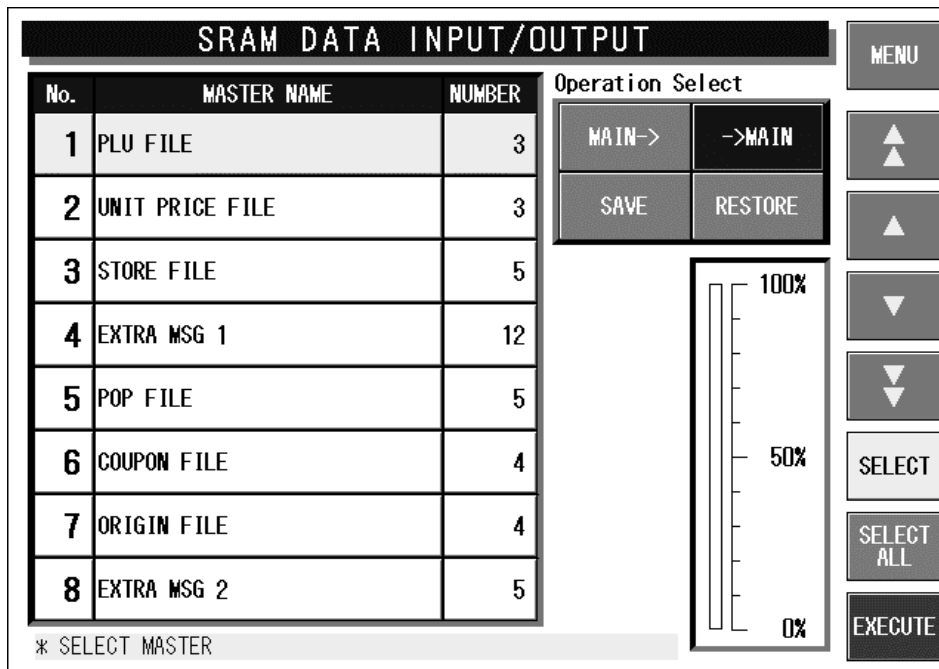

Input Master Data Selection Screen

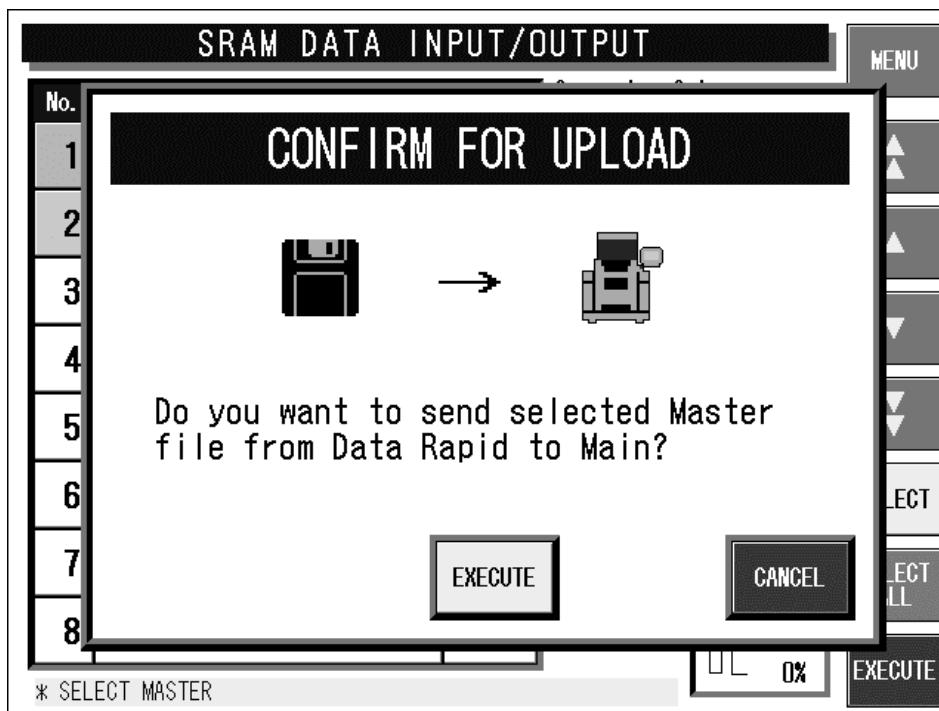

Upload Confirmation Screen

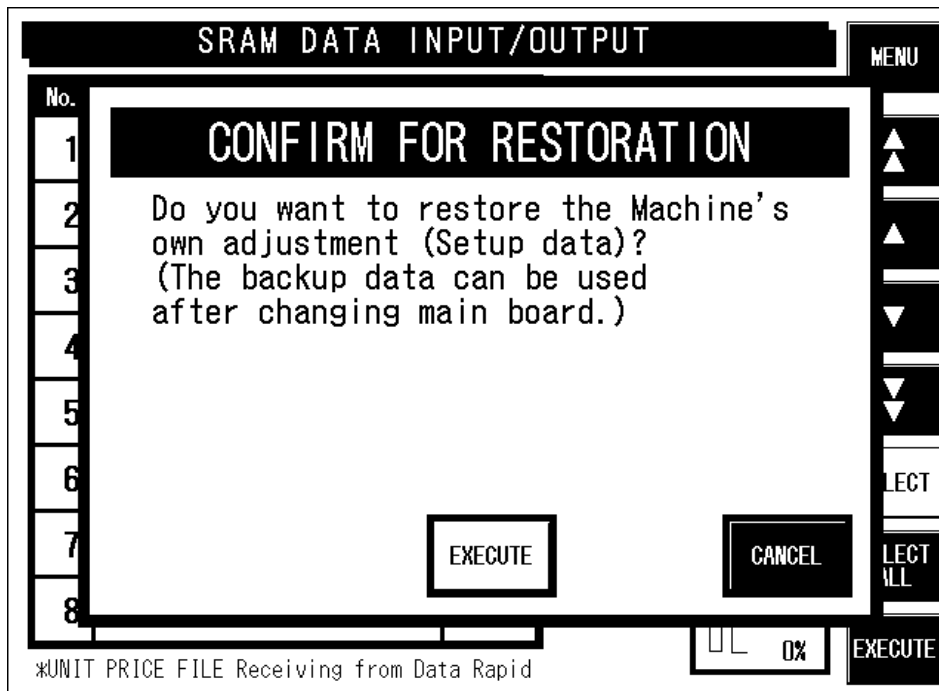

Restoration Confirmation Screen

Buttons/Display Fields	Function
MENU	Returns to the System Menu 1/2 screen.
Operation Select	<p>MAIN→ Select to output main body master data to the IF-21FD FD and SRAM main body data (set system data for each machine) to the CF-1 (main program CF). (File name: sram.dat)</p> <p>→ MAIN Select when replacing the main board or copying all data to another machine. Backup master data and permanent storage field data (system data for each machine) can be input to SRAM. (File name: sram.dat.)</p> <p>SAVE DATA Select to save the set the machine unique data in the CF-1. (File name: sram.dat.)</p> <p>RESTORE DATA Select to restore machine unique data (file name: sram.dat.) stored in the CF-1.</p>
Index Name Setting / Select	Press the corresponding button to set (edit) or select the desired index name(s). The output master data selection screen is displayed when the index name is fixed.
File Name Select (SELECT/ ALL SELECT)	Press one of these buttons to select the desired output file.
▼▲	Press to move the list index information display page up/down.
▼▲	Press to move the cursor position in the index information list display (highlighted yellow) up/down.

Buttons/Display Fields	Function
EXECUTE	<p>Output the selected file. The confirmation screen is displayed. Press [EXECUTE] to initiate processing. Press [CANCEL] to cancel processing and return to the previous screen. The permanent storage data backup confirmation screen is displayed when file output ends normally.</p> <p>Press [EXECUTE] to copy SRAM permanent storage data to the main program CF. (File name: sram.dat)</p>

4.16 FILE TRANSFER MENU

This function is used to copy data stored in the CF card to another CF card.

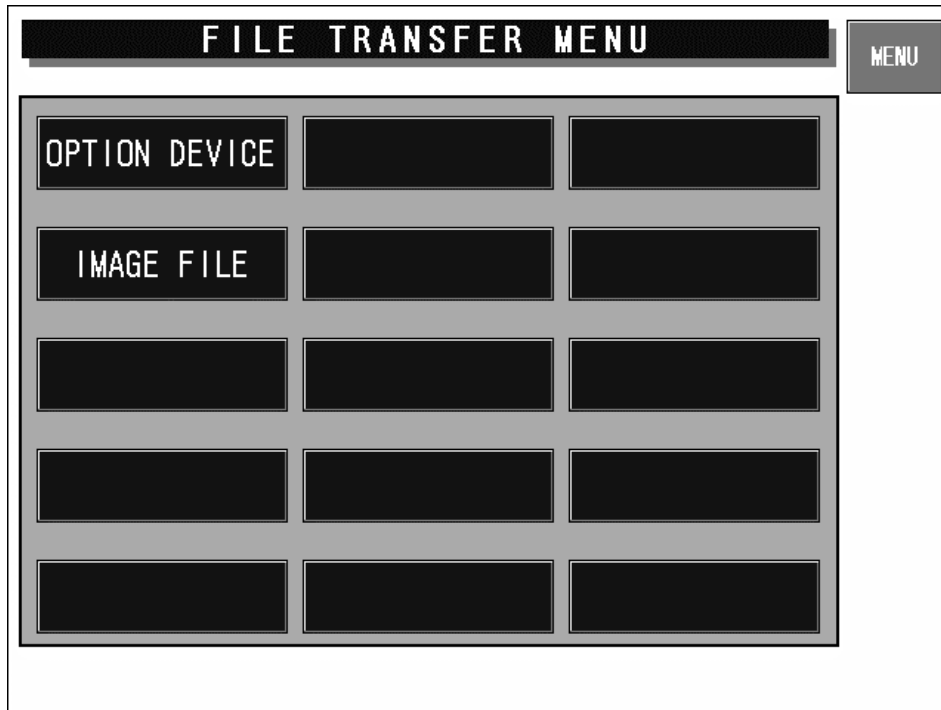

File Transfer Menu Screen

Buttons/Display Fields	Function
MENU	Returns to the System Menu 1/2 screen.
OPTION DEVICE	Press to transfer the option device program.
IMAGE FILE	Press to transfer (copy, delete) the image file.

4.16.1 OPTION DEVICE PROGRAM FILE COPY

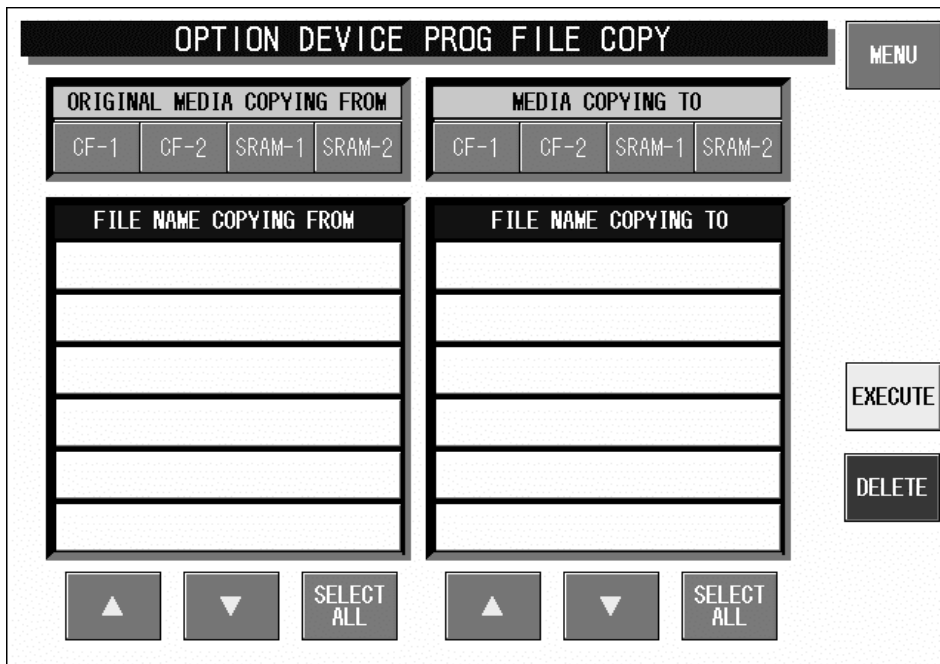

Option Device Program File Copy Screen

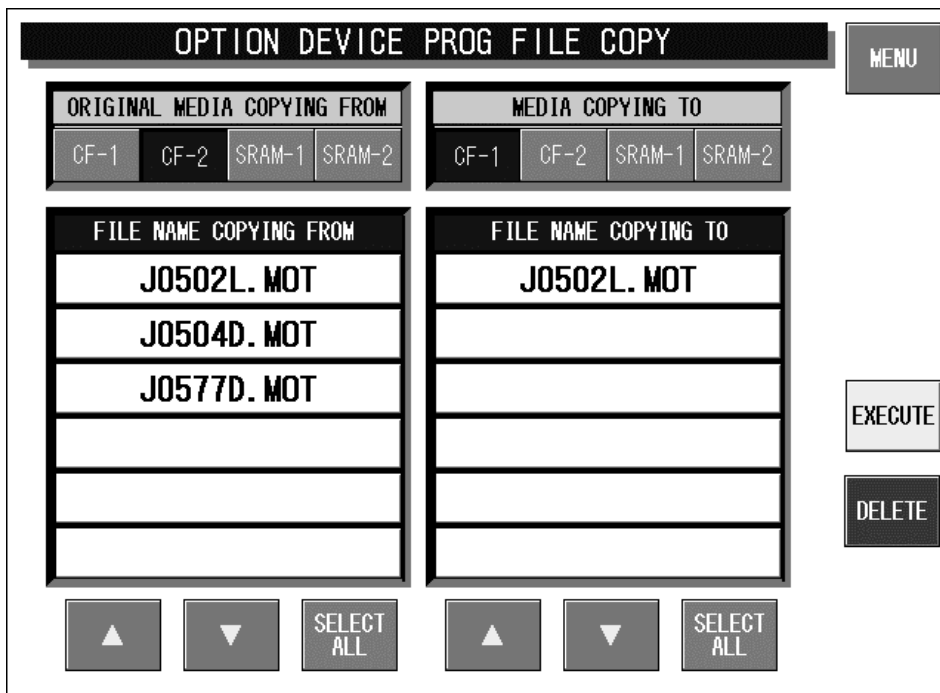

Option Device Program File Copy Screen (Example)

Buttons/Display Fields	Function
MENU	Returns to the System Menu 1/2 screen.
Copying from/ Copying to	Select copy origin and destination from the 4 card types: Press the desired button to make a selection. The selected button will change to blue.
▼ ▲	Press to move the file selection cursor up/down.
EXECUTE	The program file stored in the selected card is copied to the copy destination. Displays the execution confirmation screen. Press [EXECUTE] to copy. Press [CANCEL] to cancel and close the confirmation screen.
DELETE	Deletes the selected file.

Note: Do not turn off the power supply while copying.

4.16.2 IMAGE FILE COPY

I M A G E F I L E C O P Y								
ORIGINAL MEDIA COPYING FROM				MEDIA COPYING TO				MENU
CF-1	CF-2	SRAM-1	SRAM-2	CF-1	CF-2	SRAM-1	SRAM-2	
FILE NAME COPYING FROM				FILE NAME COPYING TO				
								EXECUTE
								DELETE
▲			▼			SELECT ALL		
▲			▼			SELECT ALL		

Image File Copy Screen

I M A G E F I L E C O P Y								
ORIGINAL MEDIA COPYING FROM				MEDIA COPYING TO				MENU
CF-1	CF-2	SRAM-1	SRAM-2	CF-1	CF-2	SRAM-1	SRAM-2	
FILE NAME COPYING FROM				FILE NAME COPYING TO				
00000001. BMP				IMAGE001. BMP				
00000002. BMP				IMAGE002. BMP				
00000003. BMP				IMAGE003. BMP				
00000004. BMP				IMAGE004. BMP				EXECUTE
00000005. BMP				IMAGE005. BMP				DELETE
00000006. BMP				IMAGE006. BMP				
▲			▼			SELECT ALL		
▲			▼			SELECT ALL		

Image File Copy Screen (Example)

Buttons/Display Fields	Function
MENU	Returns to the System Menu 1/2 screen.
Copying from/ Copying to	Select copy origin and destination from the 4 card types: Press the corresponding button to make a selection. The selected button will change to blue.
▼ ▲	Press to move the cursor up/down.
EXECUTE	The image file (BMP) stored in the selected card is copied to the copy destination. Displays the execution confirmation screen. Press [EXECUTE] to copy. Press [CANCEL] to cancel and close the confirmation screen.
DELETE	Deletes the selected file.

5

SETUP MODE

CONTENTS

5.1 STARTING PROCEDURE 5-2

5.2 SETUP MENU 5-4

5.3 EXPIRY DATE SETTING 5-6

5.4 PASSWORD SETTING 5-9

5.5 WORDWRAP WIDTH SETTING 5-10

5.6 REFERENCE DATA SETUP 5-11

5.7 TOTAL ADD SETTING 5-13

5.8 BARCODE SETUP 5-15

5.9 ITEM CODE SETTING 5-17

5.10 PLU DEFAULT DATA SETTING 5-18

5.11 PLU UPDATE SETTING 5-21

5.12 KEY LOCK SETTING 5-23

5.13 PLU DATE/TIME SETTING 5-26

5.14 PLU OPERATION SETTING 5-27

5.15 ERROR SETTING 5-28

5.16 PRINT SELECT SETTING 5-29

5.1 STARTING PROCEDURE

1. Turn the Main Power Switch lever clockwise to power ON the machine.

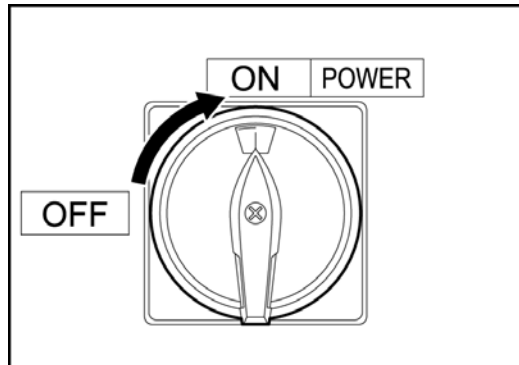

2. The Check of Return Operation screen appears. Press the [RETURN] button.

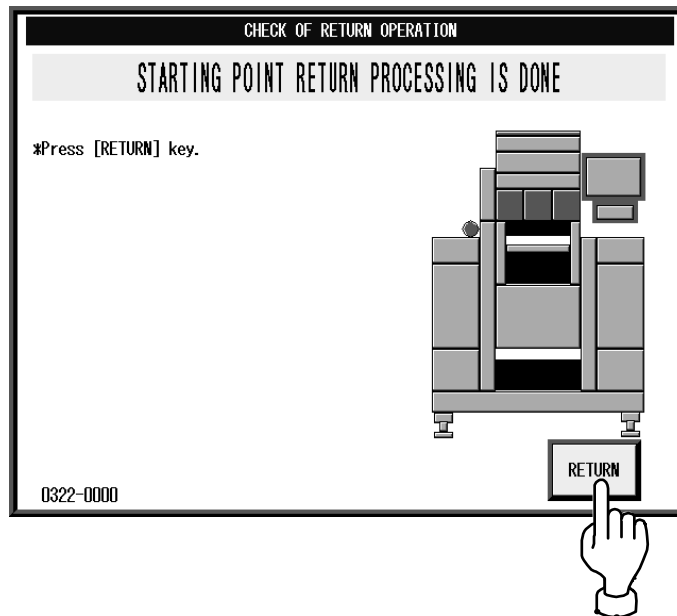

3. The initial screen appears. Press the [MENU] button on the screen.

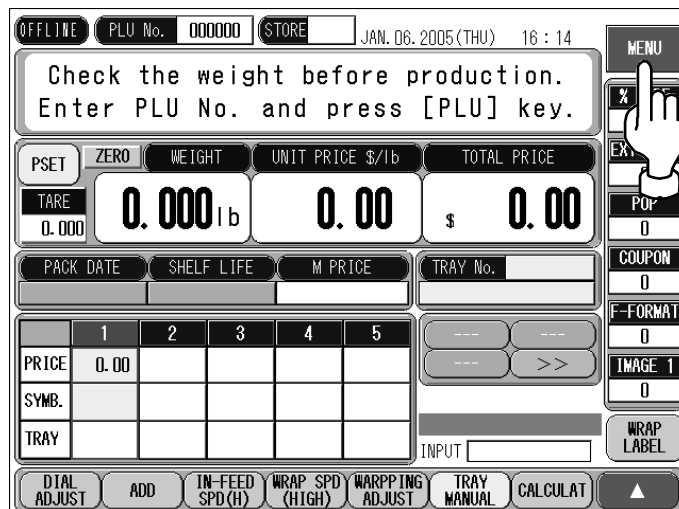

4. Press the [SETUP] button to display the Setup Menu screen.

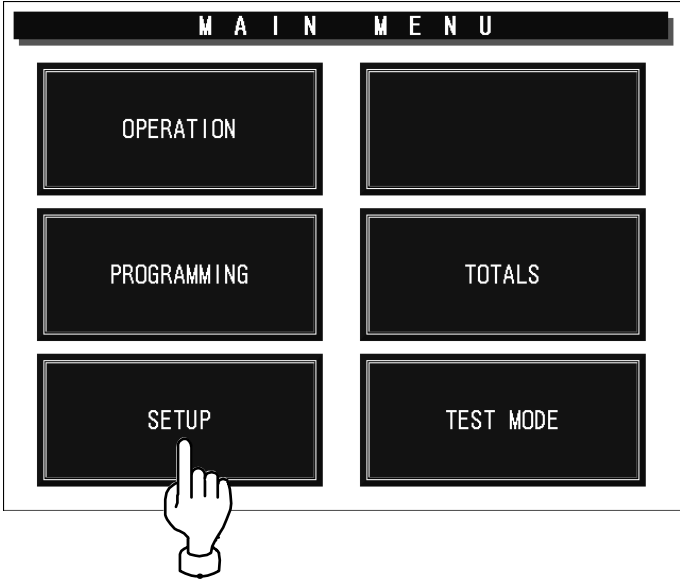

5. The Setup Menu screen appears.

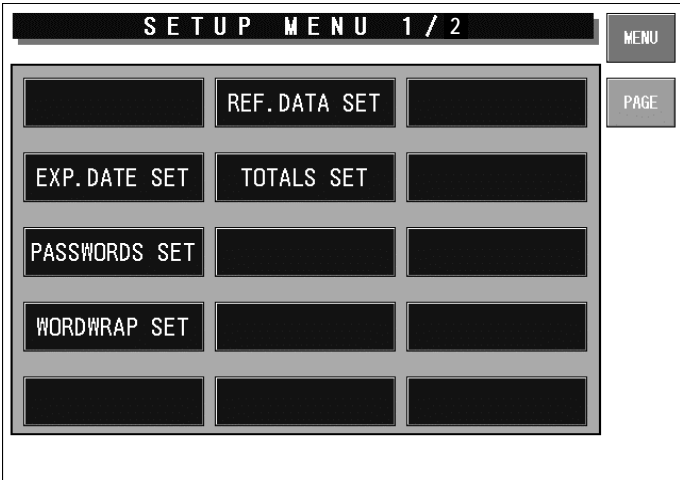

5.2 SETUP MENU

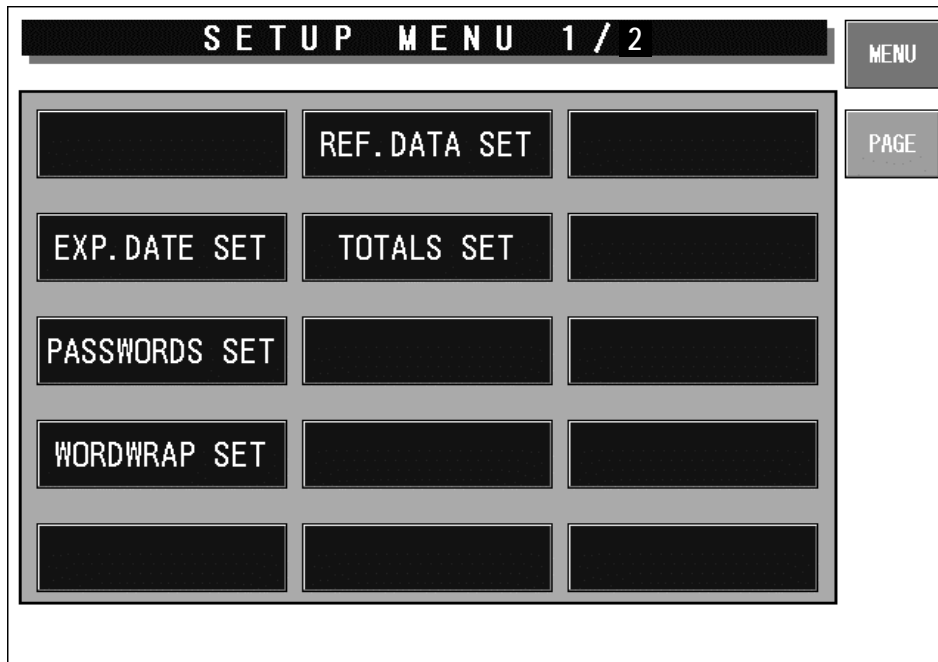

Setup Menu Screen (1/2)

Buttons/Display Fields	Function
MENU	Changes to the first screen of the Setup Menu.
PAGE	Turns over the screens.
Expiry Date Set	Changes to the Expiry Date Setting screen. Set the expiry text change days, cutoff date text, and pack date text.
Password Set	Changes to the Password Setting screen. Set the password for entering Registration, Setup, Total, and Subtraction modes.
Wordwrap Set	Changes to the Wordwrap Width Setting screen. Set the text width in 0.1mm increments for PLU name, Message, etc.for an automatic linefeed.
Reference Data Set	Changes to the Reference Data Setup screen. Specify the operation when "Refer" is selcted in the PLU registration, and set the reference data.
Total Set	Changes to the Total Add Setting screen. <ul style="list-style-type: none"> ▪ Set whether or not to add the data to totals. ▪ Set a maximum of 20 target commodities to be added to hourly totals. ▪ Set the weight data type (fixed weight, actual weight) when a fixed price commodity is added to totals.

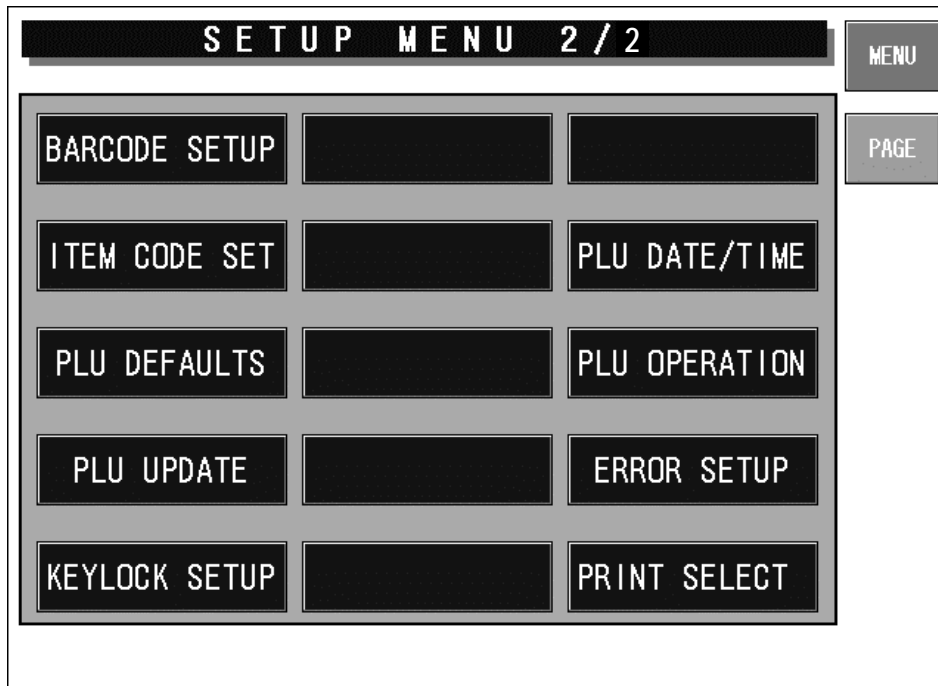

Setup Menu Screen (2/2)

Buttons/Display Fields	Function
MENU	Changes to the first screen of the Setup Menu.
PAGE	Turns over the screens.
Barcode Setup	Changes to the Barcode Setting screen. Set the POS type, POS system, and POS flag (system reference data).
Item Code Set	Changes to the Item Code Setting screen. Assign the classification code (position/digit number) in an item code, and set the code position and the digit number for a barcode.
PLU Defaults	Changes to the PLU Default Data Setting screen display. Set the default master data when newly created in the PLU registration.
PLU Update	Changes to the PLU Update screen. Perform the batch data changing process for the master data of existing commodities.
Keylock Setup	Changes to the Keylock Setup screen. Set the key lock password, and the key lock availability for each item.
PLU Date/Time	Changes to the PLU Date/Time Setting screen. Set the pack date holding function, accrued pack date processing, and time rounding.
PLU Operation	Changes to PLU Operation Setting screen. Set the number of digits for calling a PLU code, register code, wrapping mode, unit price holding function, and shop change processing.
Error Setup	Changes to the Error Setup screen. Set the processing procedure when a PLU code is not found, a price data is "0", a PLU in which the tare weight is not registered is called, or the head failure is detected.
Print Select	Changes to the Print Select screen. <ul style="list-style-type: none"> ▪ Set whether to print the barcode on the top of the tray when two labels are issued, and the barcode is set to print on the bottom label. ▪ It is referred when "System Reference" is set in the barcode print selection when two labels are issued in the store master registration.

5.3 EXPIRY DATE SETTING

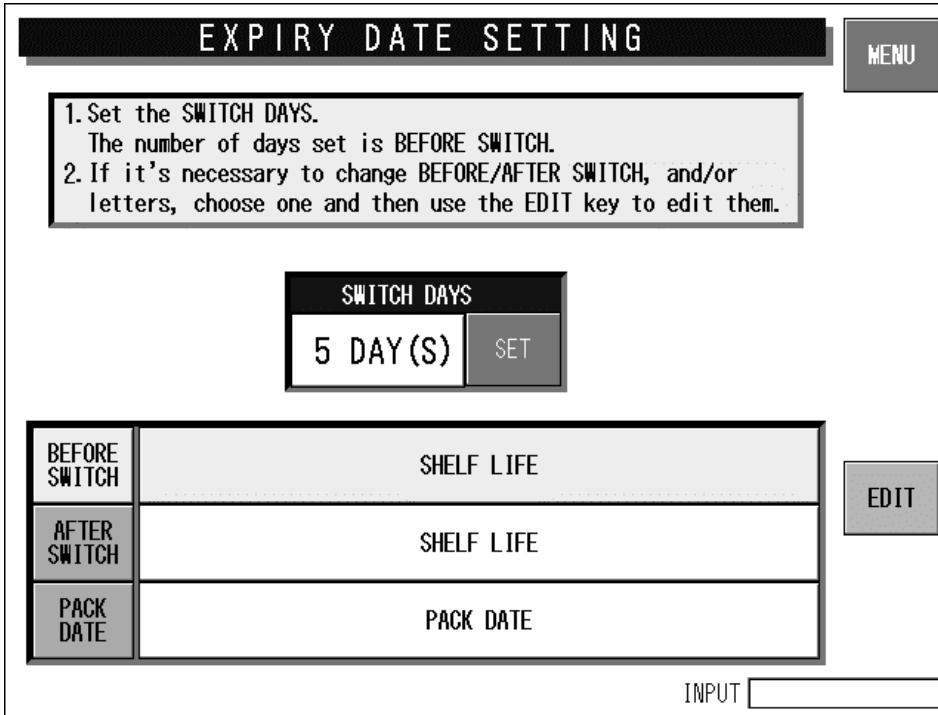

Expiry Date Setting Screen

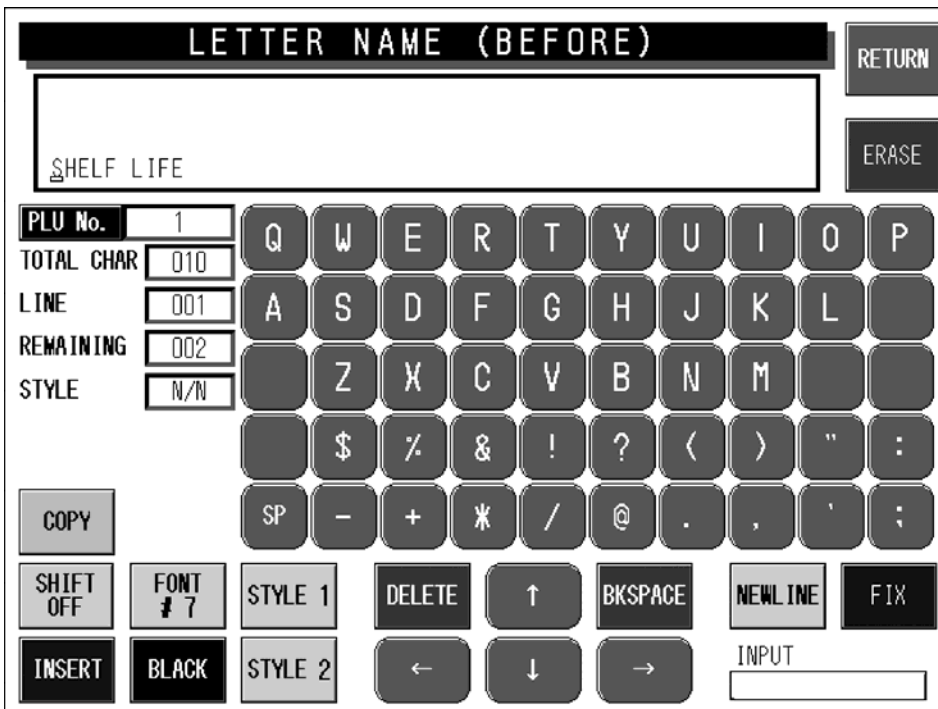

Text Edit (Before) Screen

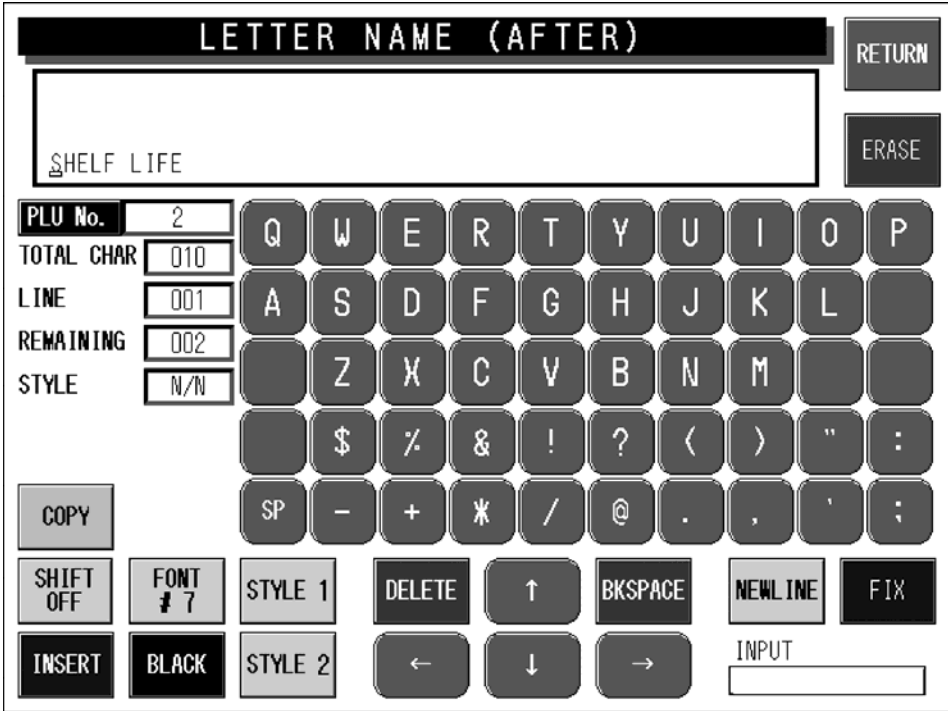

Text Edit (After) Screen

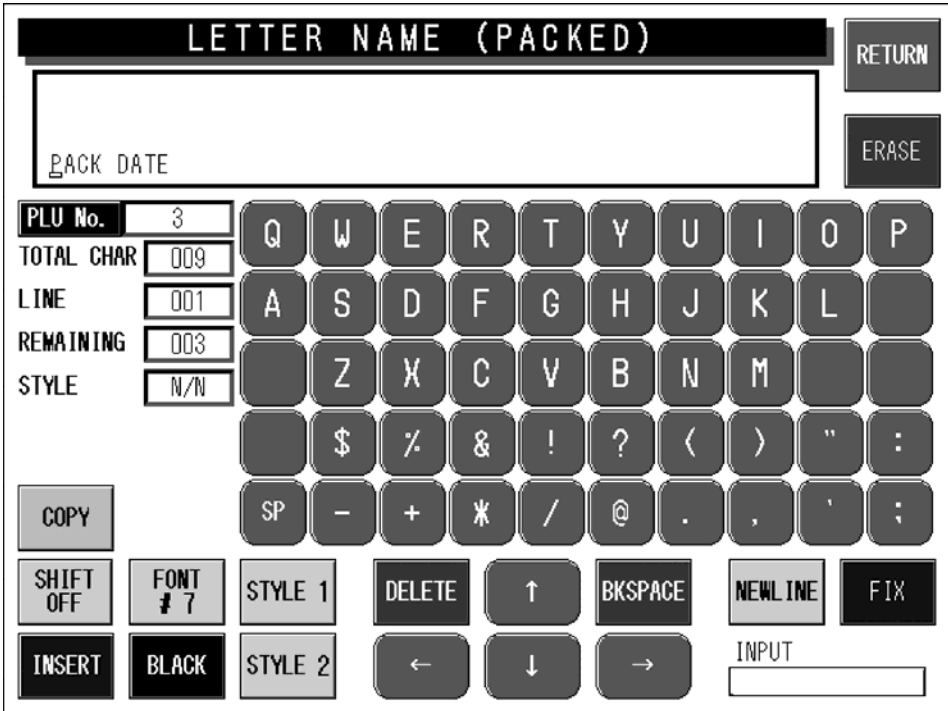

Text Edit (Packed) Screen

Buttons/Display Fields	Function
MENU	Changes to the first screen of the Setup Menu.
Switch Days	Press the [SET] button after numeric entry (0-99) to set the entered data as switching days. When the expiry date is same as or before the "Switch Days", the text in the "Before Switch" field is printed. When "0" is set in this field, switching does not happen and the text in the "Before Switch" field is printed.
Before Switch	Selects "Before Switch" field and the field color changes yellow. Press the [EDIT] button to display the text edit screen. Up to 6 characters can be registered.
After Switch	Selects "After Switch" field and the field color changes yellow. Press the [EDIT] button to display the text edit screen. Up to 6 characters can be registered.
Pack Date	Selects "Pack Date" field and the field color changes yellow. Press the [EDIT] button to display the text edit screen. Up to 6 characters can be registered.

5.4 PASSWORD SETTING

PASSWORDS SETTING

MENU

1. Password numbers could be set for different modes.
 2. Digits of Numbers could be 1 - 6.
 3. Password will be canceled if 0 is set.
 4. Leading 0(s) will be ignored as password.

PROGRAM

SET

SETTING

SET

SUB/ADD

SET

TOTALS

SET

INPUT

Password Setting Screen

Buttons/Display field	Function
MENU	Changes to the first screen of the Setup Menu.
Password	Set the password data by pressing this button after 6-digit numeric entry. Press this button after "000000" entry to cancel the password and the mode selection. Only one password can be registered.
Mode Selection Buttons	Press the desired button(s) to select the mode that requires the password entry. The selected mode button becomes blue.

Note: When you cannot access the desired mode because you forgot your password, enter "147963" and press the [SETUP] button on the screen.

5.5 WORDWRAP WIDTH SETTING

WORD WRAP WIDTH SETTING

MENU

1. Input number then push the "SET" button.
 2. Be sure to input a 3~4 digit number.
 Note: For 60mm and 64mm Set as 600.

PLU NAME

570

SET

EXTRA MSG2 WIDTH

200

SET

EXTRA MSG3 WIDTH

200

SET

EXTRA MSG2 PITCH

2

SET

EXTRA MSG3 PITCH

2

SET

INPUT

Wordwrap Width Setting Screen

Buttons/Display Fields	Function
MENU	Changes to the first screen of the Setup Menu.
PLU Name	Enter a numeric value (1-9999) and press the [SET] button to set the entered value (unit: 0.1mm) as a wordwrap width value.
Extra Message 1,2 Width	Enter a numeric value (1-9999) and press the [SET] button to set the entered value (unit: 0.1mm) as a wordwrap width value.
Extra Message 1,2 Pitch	Enter a numeric value (1-99) and press the [SET] button to set the entered value (unit: 0.1mm) as a gap between characters.

5.6 REFERENCE DATA SETUP

REFERENCE DATA SETUP 1 / 2									
					MENU				
PACK DATE PRINT	YES	NO			PACK TIME PRINT	YES	NO		
SELL BY DATE PRINT	YES	NO			PACK TIME FLAG	Design	Clock		
SHELF LIFE (days)	0				SB TIME PRINT	YES	NO		
USE BY DATE PRINT	YES	NO			SB TIME FLAG	Design	Relate		
USE BY DATE (days)	0								
UNIT TYPE	oz	lb	kg	g	PC.	BOX	BUNDLE	PACK	CUT
	SLICE	CUP	PKT	BAG	BUNCH	BOTTLE	LB	NO PRN	
INPUT <input style="width: 100px;" type="text"/>									

Reference Data Setup 1/2 Screen

REFERENCE DATA SETUP 2 / 2			
			MENU
OPEN PRICE SELECT	ON	OFF	
STANDARD TARE	0.000 lb		PAGE
LOGO #1	0		
LOGO #2	0		
LOGO #3	0		
SAFE HANDLING IMAGE No.	0		
			INPUT <input style="width: 100px;" type="text"/>

Reference Data Setup 2/2 Screen

Buttons/Display Fields	Function
MENU	Determines the settings and returns to the first screen of the Setup Menu.
PAGE	Turns over the screen.
Pack Date Print	Press "YES" or "NO" to set whether to print the Pack Date or not. This setting is effective only when "REFER" is specified by the Pack Date Print setting in the PLU registration.
Sell By Date Print	Press "YES" or "NO" to set whether to print the Sell By Date or not. This setting is effective only when "REFER" is specified by the Sell By Date Print setting in the PLU registration.
Shelf Life (days)	Enter a numeric value (0-9999) and press this field to set the entered value as the Shelf Life data. This setting is effective only when "REFER" is specified by the Shelf Life Date Print setting in the PLU registration.
Use By Date Print	Press "YES" or "NO" to set whether to print the Use By Date or not. This setting is effective only when "REFER" is specified by the Use By Date Print setting in the PLU registration.
Use By Date (days)	Enter a numeric value (0-9999) and press this field to set the entered value as the Use By Date data. This setting is effective only when "REFER" is specified by the Use By Date print setting in the PLU registration.
Pack Time Print	Press "YES" or "NO" to set whether to print the Pack Time or not. This setting is effective only when "REFER" is specified by the Pack Time Print setting in the PLU registration.
Pack Time Flag	Specify the pack time to be used. Clock: Use the system clock. Designated: Use the time designated on the following screen. <div data-bbox="673 1012 1252 1444" data-label="Image"> </div>
Sell By Time Print	Press "YES" or "NO" to set whether to print the Pack Time or not. This setting is effective only when "REFER" is specified by the Pack Time Print setting in the PLU registration.
Sell By Time Flag	Not used
Unit Type	Set the unit type of quantity data for fixed price items. This setting is effective only when "REFER" is specified by the Unit Type setting in the PLU registration.
Open Price Select	Select whether or not to allow price change in Normal Mode. This setting is effective only when "REFER" is specified by the Open Price setting in the PLU registration.
Standard Tare	Set the standard tray weight. Enter a numeric value (max. 3 digits) and press this field, then the entered data becomes the standard tray weight. This setting is effective only when "REFER" is specified by the Forced Tare setting in the PLU registration.
Logo #1, #2, #3	Enter a numeric value (max. 3 digits) and press this field, then the entered data becomes the logo data. This setting is effective only when "REFER" is specified by the Logo setting in the PLU registration.

5.7 TOTAL ADD SETTING

TOTAL ADD SETTING

MENU

- * Select ADD or NON ADD for each totals.
- * Select the weight addition mode of fixed price PLU.
- * Press [SPECIFY] key to designate PLU for the total time zone is possible. (Designation screen is displayed.)
- * Daily Total Auto Clear: YES clears daily total when 1st power on

ITEM SPECIFY

Daily Total

NON ADD

ADD

Accumulative Total

NON ADD

ADD

Periodical Total

NON ADD

ADD

Time Zone Total

NON ADD

ADD

Daily Total Auto Clear

NO

YES

Tray Total

NON ADD

ADD

Fixed Pri PLU Weight Addition Mode

FIXED WEIGHT

REAL WEIGHT

Total Add Setting Screen

TIME ZONE SET FOR INDIV. PLU

CONFIRM

PLU LIST	
000001	TEST ITEM 0001
000002	TEST ITEM 0002
000003	TEST ITEM 0003

CANCEL

INDIVIDUAL PLU BY TIME ZONE	

ADD

DELETE

Press [ADD] key to register the selected PLU. INPUT

Time Zone Set for Individual PLU Screen

OMNi-4000ST Service Manual No.085-6694-06

5-13

Buttons/Display Fields	Function
MENU	Determines the settings and returns to the first screen of the Setup Menu.
Daily Total	Select whether or not to add the data to Daily Total. The selected button color will change to blue. This is not displayed at a satellite machine in master/satellite specification.
Accumulative Total	Select whether or not to add the data to Accumulative Total. The selected button color will change to blue. This is not displayed at a satellite machine in master/satellite specification.
Periodical Total	Select whether or not to add the data to Periodical Total. The selected button color will change to blue. This is not displayed at a satellite machine in master/satellite specification.
Time Zone Total	Select whether or not to add the data to Time Zone Total. The selected button color will change to blue. This is not displayed at a satellite machine in master/satellite specification.
Daily Total Auto Clear	Select whether or not to clear Daily Total when turning off the machine. The selected button color will change to blue. This is not displayed at a satellite machine in master/satellite specification.
Tray Total	Select whether or not to add the data to Tray Total. The selected button color will change to blue. This is not displayed at a satellite machine in master/satellite specification.
Fixed Price PLU Weight Addition Mode	Select to add either "Fixed Weight" or "Real Weight" for a fixed price item to total. The selected button color will change to blue.
ITEM SPECIFY	Displays the Time Zone Set For Individual PLU screen.
CONFIRM	Determines the settings and returns to the Total Add Setting Screen. Clears the existing Daily PLU Time Zone Total.
CANCEL	Cancel the settings and returns to the Total Add Setting Screen.
ADD	Add a commodity to target commodities by pressing this button after selecting the desired PLU or entering the PLU number.
DELETE	Delete a commodity from target commodities by pressing this button after selecting the PLU to be deleted.

5.8 BARCODE SETUP

B A R C O D E S E T U P
MENU

NON-PLU13

02

SET

PLU13

49

SET

NON-PLU8

2

SET

PLU8

49

SET

Pos Code Type

NON-PLU13
NON-PLU8
PLU13
PLU8

Pos Code Kind

BARCODE FORMAT
1:FFCCCC(C/P)PPPP(C/D)

INPUT

Barcode Setup Screen

Buttons/Display Fields	Function
MENU	Determines the settings and returns to the first screen of the Setup Menu.
Non PLU 13	This is referred when "System" is set in the flag reference of the PLU registration and the code type is set as "Non PLU 13". The set flag data is displayed. Enter a numeric value (max. 2 digits) and press the [SET] button to set the entered data as a flag data.
Non PLU 8	This is referred when "System" is set in the flag reference of the PLU registration and the code type is set as "Non PLU 8". The set flag data is displayed. Enter a numeric value (max. 2 digits) and press the [SET] button to set the entered data as a flag data.
PLU 13	This is referred when "System" is set in the flag reference of the PLU registration and the code type is set as "PLU 13". The set flag data is displayed. Enter a numeric value (max. 2 digits) and press the [SET] button to set the entered data as a flag data.
PLU 8	This is referred when "System" is set in the flag reference of the PLU registration and the code type is set as "PLU 8". The set flag data is displayed. Enter a numeric value (max. 2 digits) and press the [SET] button to set the entered data as a flag data.
POS Code Type	Select the code type to be referred to when the code type is set as "Refer" in the PLU master file. Press the desired button to select among Non PLU 13, Non PLU 8, PLU 13, and PLU 8.

Buttons/Display Fields	Function																																													
POS Code Kind	<p>Select the code kind to be referred to when the code kind is set as "Refer" in the PLU master file. Press the desired field to select among 31 different kinds.</p> <div data-bbox="502 324 1412 996" style="border: 1px solid black; padding: 5px;"> <table border="1" style="width: 100%; border-collapse: collapse; text-align: center;"> <thead> <tr> <th colspan="3" style="background-color: black; color: white; padding: 2px;">R A R C O N F S E T I P</th> </tr> </thead> <tbody> <tr> <td style="width: 33%; padding: 2px;">FFCCCC (C/P)PPPP (C/D)</td> <td style="width: 33%; padding: 2px;">FFCCCCWWWWW (C/D)</td> <td style="width: 33%; padding: 2px;">FFCCCCQQQQ (C/D)</td> </tr> <tr> <td style="padding: 2px;">FFCCCCPPPP (C/D)</td> <td style="padding: 2px;">FFCCCCPPPP (C/D)</td> <td style="padding: 2px;"></td> </tr> <tr> <td style="padding: 2px;">FCCCCC (C/P)PPPP (C/D)</td> <td style="padding: 2px;">FCCCCC (C/P)PPPP (C/D)</td> <td style="padding: 2px;"></td> </tr> <tr> <td style="padding: 2px;">FFCCCCPPPP (C/D)</td> <td style="padding: 2px;">FFCCCC (C/P)WWWW (C/D)</td> <td style="padding: 2px;"></td> </tr> <tr> <td style="padding: 2px;">FCCCCC (C/P)PPPP (C/D)</td> <td style="padding: 2px;">FCCCCPPPP (C/D)</td> <td style="padding: 2px;"></td> </tr> <tr> <td style="padding: 2px;">FFCCCCWWWW (C/D)</td> <td style="padding: 2px;">FCCWWWWPPPP (C/D)</td> <td style="padding: 2px;"></td> </tr> <tr> <td style="padding: 2px;">FCCCCCWWWW (C/D)</td> <td style="padding: 2px;">FFCCCCQPPPP (C/D)</td> <td style="padding: 2px;"></td> </tr> <tr> <td style="padding: 2px;">FCCCCI IIIII (C/D)</td> <td style="padding: 2px;">FIIIIIIPPPPP (C/D)</td> <td style="padding: 2px;"></td> </tr> <tr> <td style="padding: 2px;">FFCCCCPPPP (C/D)</td> <td style="padding: 2px;">FFIIIIIIPPPPP (C/D)</td> <td style="padding: 2px;"></td> </tr> <tr> <td style="padding: 2px;">FFCCCCWWWW (C/D)</td> <td style="padding: 2px;">FCCCCPPPPPP (C/D)</td> <td style="padding: 2px;"></td> </tr> <tr> <td style="padding: 2px;">FFCCCC (C/P)WWWWW (C/D)</td> <td style="padding: 2px;">FIIIIIIPPPPP (C/D)</td> <td style="padding: 2px;"></td> </tr> <tr> <td style="padding: 2px;">FFMMCCPPPP (C/D)</td> <td style="padding: 2px;">FFIIIIIIPPPPP (C/D)</td> <td style="padding: 2px;"></td> </tr> <tr> <td style="padding: 2px;">FFMMCCPPPP (C/D)</td> <td style="padding: 2px;">FCCCCPPPPPP (C/D)</td> <td style="padding: 2px;"></td> </tr> <tr> <td style="padding: 2px;">FFCCCC (D)PPPP (C/D)</td> <td style="padding: 2px;">FFCCCCPPPP (C/D)</td> <td style="padding: 2px;"></td> </tr> </tbody> </table> <div style="margin-top: 10px;"> <p>Pos Code NO</p> <p>Pos Code </p> <p style="text-align: right; margin-top: 10px;">INPUT </p> </div> </div>	R A R C O N F S E T I P			FFCCCC (C/P)PPPP (C/D)	FFCCCCWWWWW (C/D)	FFCCCCQQQQ (C/D)	FFCCCCPPPP (C/D)	FFCCCCPPPP (C/D)		FCCCCC (C/P)PPPP (C/D)	FCCCCC (C/P)PPPP (C/D)		FFCCCCPPPP (C/D)	FFCCCC (C/P)WWWW (C/D)		FCCCCC (C/P)PPPP (C/D)	FCCCCPPPP (C/D)		FFCCCCWWWW (C/D)	FCCWWWWPPPP (C/D)		FCCCCCWWWW (C/D)	FFCCCCQPPPP (C/D)		FCCCCI IIIII (C/D)	FIIIIIIPPPPP (C/D)		FFCCCCPPPP (C/D)	FFIIIIIIPPPPP (C/D)		FFCCCCWWWW (C/D)	FCCCCPPPPPP (C/D)		FFCCCC (C/P)WWWWW (C/D)	FIIIIIIPPPPP (C/D)		FFMMCCPPPP (C/D)	FFIIIIIIPPPPP (C/D)		FFMMCCPPPP (C/D)	FCCCCPPPPPP (C/D)		FFCCCC (D)PPPP (C/D)	FFCCCCPPPP (C/D)	
R A R C O N F S E T I P																																														
FFCCCC (C/P)PPPP (C/D)	FFCCCCWWWWW (C/D)	FFCCCCQQQQ (C/D)																																												
FFCCCCPPPP (C/D)	FFCCCCPPPP (C/D)																																													
FCCCCC (C/P)PPPP (C/D)	FCCCCC (C/P)PPPP (C/D)																																													
FFCCCCPPPP (C/D)	FFCCCC (C/P)WWWW (C/D)																																													
FCCCCC (C/P)PPPP (C/D)	FCCCCPPPP (C/D)																																													
FFCCCCWWWW (C/D)	FCCWWWWPPPP (C/D)																																													
FCCCCCWWWW (C/D)	FFCCCCQPPPP (C/D)																																													
FCCCCI IIIII (C/D)	FIIIIIIPPPPP (C/D)																																													
FFCCCCPPPP (C/D)	FFIIIIIIPPPPP (C/D)																																													
FFCCCCWWWW (C/D)	FCCCCPPPPPP (C/D)																																													
FFCCCC (C/P)WWWWW (C/D)	FIIIIIIPPPPP (C/D)																																													
FFMMCCPPPP (C/D)	FFIIIIIIPPPPP (C/D)																																													
FFMMCCPPPP (C/D)	FCCCCPPPPPP (C/D)																																													
FFCCCC (D)PPPP (C/D)	FFCCCCPPPP (C/D)																																													

5.9 ITEM CODE SETTING

ITEM CODE SETTING

MENU

Set the code digit after the code type is selected.
 The classification code/JAN code can be chosen 4/8 digits.

CODE SELECT 1 DIGIT		
DEPT CODE	GROUP CODE	SECTION CD

1	2	3	4	5	6	7	8
---	---	---	---	---	---	---	---

JAN CODE 2 DIGIT	
JAN 8	JAN 13

1	2	3	4	5	6	7	8
---	---	---	---	---	---	---	---

Item Code Setting Screen

Buttons/Display Fields	Function
MENU	Determines the settings and returns to the first screen of the Setup Menu.
Code Digit Display	The set digit(s) is displayed.
Classification Code Select	Select one of code types "Department Code" "Group Code" and "Section Code" of which code digit(s) is displayed.
Classification Code Digit Set	Set the code digit position (max. 4 digits) for the selected code type by pressing the contiguous fields.
JAN Code Select	Select one of code types "JAN 8" and "JAN 13" of which code digit(s) is displayed.
JAN Code Digit Set	Set the code digit position (max. 8 digits) for the selected code type by pressing the contiguous fields.

5.10 PLU DEFAULT DATA SETTING

PLU DEFAULT DATA SETTING 1					
Set the default data to be used when a new PLU is created.					
SALES MODE	0:WEIGH	TARE (0~9.995)	0.000	BARCODE TYPE	0:REFER
PRICE	0.00				
MARKDOWN FLAG	0:NORMAL	PACK DATE PRINT	0:REFER	POS FLAG	02
MARKDOWN AMOUNT	0.00	SB DATE PRINT	0:REFER	BARCODE	0000000000
FIXED WEIGHT	0.000	SHELF LIFE (days)	1	OPEN PRICE	0:REFER
PACK QUANTITY	0	USE BY PRINT	0:REFER	FORCED TARE	0:REFER
NUTRITION NO.	0	USE BY (days)	0	PROP. TARE (0~50.0)	0.0%

INPUT

PLU Default Data Setting 1 Screen

PLU DEFAULT DATA SETTING 2					
Set the default data to be used when a new PLU is created.					
EXTRA MESSAGE 1	0	FREE MSG1 No.	0	COUPON MESSAGE	0
EXTRA MESSAGE 2	0	FREE MSG2 No.	0	LOGO #1 (0~999)	0
EXTRA MESSAGE 3	0	FREE MSG3 No.	0	LOGO #2 (0~999)	0
PACK TIME PRINT	0:REFER	FREE MSG4 No.	0	LOGO #3 (0~999)	0
PACK TIME DATA	--:--	FREE MSG5 No.	0	LABEL FORMAT	0
SB TIME PRINT	0:REFER			SECOND LABEL	1:YES
SB TIME DATA	--:--	POP MESSAGE	0	2nd LABEL FORMAT	0

INPUT

PLU Default Data Setting 2 Screen

PLU DEFAULT DATA SETTING 3					
Set the default data to be used when a new PLU is created.					
DEPARTMENT	0	TRAY No.	0	LABELING MODE	1:AUTO LAB
GROUP	00	WRAP MODE	1:WRAP/LAB		
ITEM CODE	00000000	INFEED SPEED	1:HIGH SPE		
UNIT TYPE	0:REFER	WRAP SPEED	0:TRAY REF		
UPPER WT. LIMIT	0.000	LABEL ROTATION	0:NORMAL L		
LOWER WT. LIMIT	0.000	TRAY VOLUME	0:NO VOLUM		
SH IMAGE No(0~999)	0	AUTO DETECTION	2:AUTO TRA		

INPUT

PLU Default Data Setting 3 Screen

Buttons/Display Fields	Function
MENU	Determines the settings and returns to the first screen of the Setup Menu.
PAGE	Turns over the screen.
Default Data Settin Items	Each button color has its meaning: <ul style="list-style-type: none"> ● Background → Green: Unit price master data, Blue: PLU master data ● Characters → Black: Requires numeric entry, White: Make a selection

PLU DEFAULT DATA SETTING 1					
Set the default data to be					
SALES MODE	0:WEIGH	TAY (0~9)		REFER	
PRICE	0.00				
MARKDOWN FLAG	0:NORWAL	PACK. PRI		2	
MARKDOWN AMOUNT	0.00	SB T. PRI		00000	
FIXED WEIGHT	0.000	SHELF (da)		REFER	
PACK QUANTITY	0	USE PRI		REFER	
NUTRITION NO.	0	USE (da)		0%	

INPUT

PLU DEFAULT DATA SETTING 1					
Set the default data to be					
SALES MODE	0:WEIGH	TAY (0~9)		REFER	
PRICE	0.00				
MARKDOWN FLAG	0:NORWAL	PACK. PRI		2	
MARKDOWN AMOUNT	0.00	SB T. PRI		00000	
FIXED WEIGHT	0.000	SHELF (da)		REFER	
PACK QUANTITY	0	USE PRI		REFER	
NUTRITION NO.	0	USE (da)		0%	

INPUT

PLU DEFAULT DATA SETTING 2 MENU

Set the default data to be

EXTRA MESSAGE 1	0	FREE	NO	REFER	
EXTRA MESSAGE 2	0	FREE	NO	PROHIBIT	
EXTRA MESSAGE 3	0	FREE	NO	DESIGNATE	
PACK TIME PRINT	0:REFER	FREE	NO	CLOCK	
PACK TIME DATA	--:--	FREE	NO		
SB TIME PRINT	0:REFER				YES
SB TIME DATA	--:--	PC	MESS		

INPUT

PLU DEFAULT DATA SETTING 2 MENU

Set the default data to be

EXTRA MESSAGE 1	0	FREE	NO	REFER	
EXTRA MESSAGE 2	0	FREE	NO	PROHIBIT	
EXTRA MESSAGE 3	0	FREE	NO	RELATIVE	
PACK TIME PRINT	0:REFER	FREE	NO		
PACK TIME DATA	--:--	FREE	NO		
SB TIME PRINT	0:REFER				YES
SB TIME DATA	--:--	PC	MESS		

INPUT

PLU DEFAULT DATA SETTING 3 MENU

Set the default data to be

DEPARTMENT	0	TRAY		REFER	CUT
GROUP	00	WRAP		oz	SLICE
ITEM CODE	0000000	INER	SPE	lb	CUP
UNIT TYPE	0:REFER	WR	SPE	kg	PKT
UPPER WT. LIMIT	0.000	LAE	ROTA	g	BAG
LOWER WT. LIMIT	0.000	TR	VOLU	PC.	BUNCH
SH IMAGE No (0~999)	0	AU	DETEC	BOX	BOTTLE
				BUNDLE	LB
				PACK	NON PRN

INPUT

PLU DEFAULT DATA SETTING 3 MENU

Set the default data to be

DEPARTMENT	0	TRAY		REFER	CUT
GROUP	00	WRAP		oz	SLICE
ITEM CODE	0000000	INER	SPE	lb	CUP
UNIT TYPE	0:REFER	WR	SPE	kg	PKT
UPPER WT. LIMIT	0.000	LAE	ROTA	g	BAG
LOWER WT. LIMIT	0.000	TR	VOLU	PC.	BUNCH
SH IMAGE No (0~999)	0	AU	DETEC	BOX	BOTTLE
				BUNDLE	LB
				PACK	NON PRN

INPUT

PLU DEFAULT DATA SETTING 3 MENU

Set the default data to be

DEPARTMENT	0	TRAY		WRAP/LABEL	
GROUP	00	WRAP		LABEL	
ITEM CODE	0000000	INER	SPE	WRAP	
UNIT TYPE	0:REFER	WR	SPE		
UPPER WT. LIMIT	0.000	LAE	ROTA		
LOWER WT. LIMIT	0.000	TR	VOLU		
SH IMAGE No (0~999)	0	AU	DETEC		

INPUT

PLU DEFAULT DATA SETTING 3 MENU

Set the default data to be

DEPARTMENT	0	TRAY		HIGH SPEED	
GROUP	00	WRAP		MEDIUM SPEED	
ITEM CODE	0000000	INER	SPE	LOW SPEED	
UNIT TYPE	0:REFER	WR	SPE		
UPPER WT. LIMIT	0.000	LAE	ROTA		
LOWER WT. LIMIT	0.000	TR	VOLU		
SH IMAGE No (0~999)	0	AU	DETEC		

INPUT

PLU DEFAULT DATA SETTING 1 MENU

Set the default data to be

SALES MODE	0:WEIGH	TA	(0~9)	NORMAL	
PRICE	0.00			SPECIAL	
MARKDOWN FLAG	0:NORMAL	PACK	PR	-3	REFER
MARKDOWN AMOUNT	0.00	SB	PR	-X	
FIXED WEIGHT	0.000	SHELF	(da)	SPL U/P	2
PACK QUANTITY	0	USE	PR	-U/P	00000
NUTRITION No.	0	USE	(da)	-XU/P	REFER

INPUT

5.11 PLU UPDATE SETTING

P L U U P D A T E			
1. Select the column & U.Price No., then set data both before/after. 2. Use FULL EXECUTE key to change all selected column data at once. (2. SELECT EXECUTE key:Effective only for selected matched column.)			
U. PRICE No.	1	2	3
	4	5	
SELECT	ITEM NAME	BEFORE	AFTER
	PLU CODE	0000000	
	PACK DATE PRINT	YES	
	PACK TIME PRINT	NO	
	PACK TIME SELECT	CLOCK	
	PACK TIME	0:00	
	USE BY DATE PRINT	YES	
PLUNo. RANGE	000000	~	000000
	INPUT		

PLU Update Screen

Buttons/Display Fields	Function
MENU	Determines the settings and returns to the first screen of the Setup Menu.
▲ ▼ ▲ ▼	Changes to the previous or next screen.
▲ ▼	Moves the cursor up or down.
SELECT	Selection can be made for items to be collectively changed. Master data at the cursor position is selected. When selected, "●" is displayed in the selected field at the cursor position on the list. Selection cannot be made when no data is set in "After" field.
SELECT EXECUTE	Executes changes in "After" field for the selected items only to the PLU master file of which "Before" data matches.
FULL EXECUTE	Executes changes in "After" field for the selected items only to all PLU master files.
Unit Price No.	Select the desired unit price master file among "1" through "5".
Item Name	The name of master item to be collectively changed is displayed. (See the master name list below)
Before	Data can be set in this field when pressed after numeric entry. Selection items appear when pressed without numeric entry.
After	Data can be set in this field when pressed after numeric entry. Selection items appear when pressed without numeric entry.
PLU No. Range	Specifies the PLU range to be collectively changed.

Master Name	Before / After Data Range	Default Value
Sales Mode	Weigh / Non-Weigh / Weigh & Fixed Price	Weigh
Unit Price	0.00 - 999.99	0.00
Fixed Price	0.00 - 999.99	None
Markdown Price Mode	Refer to "PLU Data Registration" in Programming Mode.	Normal
Markdown Price	Depending on "Markdown Price Mode"	0.00
Fixed Weight	0.000 - 99.999	0.000
Pack Quantity	0 - 999	0
Tare	0.000 - 5.998	0.000
Pack Data Print	Refer / Yes / No	Refer
Sell-By Data Print	Refer / Yes / No	Refer
Shelf Life Time	1 day - 9999 day(s)	1 day(s)
Use-By Print	Refer / Yes / No	Refer
Use-By (day)	0 day(s)	0 day(s)
Barcode Type	Refer / Non-PLU 13 / Non-PLU 8 / PLU 13/ PLU 8	Refer
POS Flag	00 - 99	02
POS Code	0000000000 - 9999999999	0000000000
Open Price	Refer / Prohibit / Allow	Refer
Forced Tare	Refer / Yes / No	Refer
Extra Message 1	0 - 999999	0
Extra Message 2	0 - 999999	0
Extra Message 3	0 - 999999	0
Pack Time Print	Refer / Yes / No	Refer
Pack Time Mode	Refer / Designate / Clock	Refer
Pack Time Data	0:00 - 23:59	0:00
Sell-By Time Print	Refer / Yes / No	Refer
Sell-By Time Mode	Refer / Relative	Refer
Use-By Time	0 hour(s) - 9999 hour(s)	0 hour
Free 1 No.	0 - 999999	0
Free 2 No.	0 - 999999	0
Free 3 No.	0 - 999999	0
Free 4 No.	0 - 999999	0
Free 5 No.	0 - 999999	0
POP No.	0 - 999	0
Coupon Message	0 - 999999	0
Image 1 No.	0 - 999	0
Image 2 No.	0 - 999	0
Image 3 No.	0 - 999	0
Label Format	0 - 999	0
Second Label	Yes / No	YES
Second Label Format	0 - 99	0
Item Code	00000000 - 99999999	00000000
Unit Type	Refer to "PLU Data Registration" in Programming Mode.	Refer
Upper Weight Limit	0.000 - 99.999	0.000
Lower Weight Limit	0.000 - 99.999	0.000
Tray No.	0 - 9999	0
Wrapping Mode	Wrap & Label / Label / Wrap	Wrap & Label
Infeed Speed	High Speed / Medium Speed / Low Speed	High Speed
Wrapping Speed	Tray Refer / High Speed / Medium Speed / Low Speed	Tray Refer
Label Rotation	Normal Label / Horizontal Label / Vertical Label	Normal Label
Tray Volume	No Volume / Low Volume / Medium Volume / High Volume	No Volume
Auto Detection	Auto Tray / Tray Designate	Auto Tray
Labeling Mode	Auto Label / Manual Label	Auto Label

5.12 KEY LOCK SETTING

KEYLOCK SETTING

MENU

PAGE

UNLOCK PASSWORD

FUNCTION
NUM FUNCTION
TOUCH PANEL
STROKE KEY

AUTO	NONE	DELETE	NONE	TotalModif	NONE
ADD	NONE	DEL PLU(S)	NONE	ERROR LOG	NONE
Weigh/F.Pr	NONE	ORDER	NONE	WRAP ADJUS	NONE
B-LabelTyp	NONE	WeightChec	NONE	VOLUMN	NONE
SUBTOTAL	NONE	B-LABEL PR	NONE	IN-FEED SP	NONE
TOTALS	NONE	F-LABEL PR	NONE	WRAP SPEED	NONE

FUNCTION
1 / 2

INPUT

Key Lock Setting 1/5 Screen

KEYLOCK SETTING

MENU

PAGE

UNLOCK PASSWORD

FUNCTION
NUM FUNCTION
TOUCH PANEL
STROKE KEY

TODAY	NONE	BAR YES/NO	NONE		
SubLabelPR	NONE	One/TwoCol	NONE		
EyeCatchPR	NONE	CALCULATOR	NONE		
TRAY AUTO	NONE	F-Label Typ	NONE		
LABEL POS	NONE	B-LABEL PO	NONE		
Hor/Ver. Lb	NONE				

FUNCTION
2 / 2

INPUT

Key Lock Setting 2/5 Screen

KEYLOCK SETTING

UNLOCK PASSWORD	0000
-----------------	------

FUNCTION	NUM FUNCTION	TOUCH PANEL	STROKE KEY
----------	--------------	-------------	------------

POP	NONE	B-LabelFrm	NONE	FREE MSG 3	NONE
COUPON	NONE	IMAGE 1 No	NONE	FREE MSG 4	NONE
EXT MSG 3	NONE	IMAGE 2 No	NONE	FREE MSG 5	NONE
EXT MSG 2	NONE	ORIGIN	NONE		
EXT MSG 1	NONE	FREE MSG 1	NONE		
F-LabelFrm	NONE	FREE MSG 2	NONE		

NUM FUNC	1 / 1	INPUT	
----------	-------	-------	--

Key Lock Setting 3/5 Screen

KEYLOCK SETTING

UNLOCK PASSWORD	1234
-----------------	------

FUNCTION	NUM FUNCTION	TOUCH PANEL	STROKE KEY
----------	--------------	-------------	------------

LINE STATE	NONE	DATE AREA	NONE		
PLU No.	NONE	M PRICE	NONE		
STORE	NONE	TRAY AREA	NONE		
ITEM AREA	NONE	5PRICE	NONE		
MEMO	NONE	ACT MODE	NONE		
WT/PRICE	NONE				

TOUCH PANEL	1 / 1	INPUT	
-------------	-------	-------	--

Key Lock Setting 4/5 Screen

KEYLOCK SETTING

UNLOCK PASSWORD

0000

MENU

FUNCTION

NUM FUNCTION

TOUCH PANEL

STROKE KEY

PAGE

PRESET	NONE				
FIX	NONE				
UNIT PRICE	NONE				
TARE	NONE				

STROKE KEY

1 / 1

INPUT

Key Lock Setting 5/5 Screen

Buttons/Display Fields	Function
MENU	Determines the settings and returns to the first screen of the Setup Menu.
PAGE	Truns over the screen.
Unlock Password	Press this filed after numeric entry (4 numeric digits) to set a password to make "Key Unlock" of a function key effective.
Key Lock Objective Group	Slect one of the the following key groups: <ul style="list-style-type: none"> • Function key group • Numeric function key group • Touck panel key group • Stroke key group
Key Lock Items	Select "Yes" to lock the key, or "None" not to lock the key.

5.13 PLU DATE/TIME SETTING

PLU DATE/TIME SETTING

MENU

1. FIX: Keeps data until main power off.
 BY PLU: Keeps data until the next PLU is called.
 REAL: Print date of the calendar inside the machine.

2. When Accrued Pack Date is set as +1 day, Pack Date of Accrued PLU is set as +1 day to actual date. (NOTE: It is unable to set +1 day when Pack Date Hold is set as FIX) When HOLD is set, temporary change data is retained.

3. The time rounding is set at 0/1/2/5/10/15/30.
 0: [00 min] fixed; 1: no rounding

Pack Date Hold

FIX

BY PLU

REAL

Accrued Pack Date

NO PROCESS

+1 DAY

HOLD

TIME ROUNDING

1

SET

INPUT

PLU Date/Time Setting Screen

Buttons/Display Fields	Function
MENU	Determines the settings and returns to the first screen of the Setup Menu.
Pack Date Hold	Select one of the following items: <ul style="list-style-type: none"> • Fix: Pack date and time which have been set after the power was turned on will be held until the power will be turned on again, or data will be changed. When "+1 Day" is selected in the Accrued Pack Date, the date changes to holding condition. • By PLU: Pack date and time at the time of PLU call is held until next PLU is called. • Real: Pack date and time are printed when the label is printed.
Accrued Pack Date	Select one of the the following items: <ul style="list-style-type: none"> • No process: Temporary change data is canceled when next PLU is called and becomes the date of that day. • +1 day: The pack date will become the date added by one day to that day. When "Fix" is selected in the Pack Date Hold, this selection cannot be made. • Hold: Data that has been changed temporarily as an accrued pack date will be held until next PLU is called.
Time Rounding	Select one of the the following items: <ul style="list-style-type: none"> • 0: 00 minute fixed • 1: No rounding • 2: Touch panel key group • 5: 05 minutes • 10: 10 minutes • 15: 15 minutes • 30: 30 minutes

5.14 PLU OPERATION SETTING

PLU OPERATION SETTING

MENU

1. Unit Price and Printer Change Selection is effective only when Store Selection is YES.

2. FIX: Keeps data until main power off.
BY PLU: Keeps data until the next PLU is called.

3. Unit Price Call Sel: Set Default Unit Price No. at PLU calling.

PLU Digit

4 DIGIT
6 DIGIT
8 DIGIT

Reg. Code HOLD

FIX
BY PLU

Wrapping Mode HOLD

FIX
BY PLU

Unit Price Call Selection

U. Price No. 1
LAST U. PRICE

Store Selection

NO
YES

Unit Price Selection

NO
YES

Printer Change Selection

BY STORE
BY EYECATCH

PLU Operation Setting Screen

Buttons/Display Fields	Function
MENU	Determines the settings and returns to the first screen of the Setup Menu.
PLU Digit	Select the number of digits (4/6/8) when calling a PLU.
Store Selection	Select whether or not to call a store in the normal mode.
Unit Price Selection	Select whether or not to fix the Unit Price No. that is set to the called store.
Register Code Hold	Select one of following items to hold the register code: <ul style="list-style-type: none"> • Fix: The register code which has been set after the power was turned on will be held until the power will be turned on again, or data will be changed. • By PLU: The register code will be updated every time the PLU is called.
Wrapping Mode Hold	Select one of the the following items to hold the wrapping mode: <ul style="list-style-type: none"> • Fix: The wrapping mode which has been set after the power was turned on will be held until the power will be turned on again, or data will be changed. • By PLU: The wrapping mode will be updated every time the PLU is called.
Printer Change Selection	When the machine is set as "Store change available", select one of the the following items to determine the printer changing method: <ul style="list-style-type: none"> • By Store: This is effective only when the machine is set as "Store change available", the printer number registered in the store master file is given priority. • By Eye-catch: The printer is selected according to the eye-catch (label print pattern).
Unit Price Call Selection	Perform the holding selection for the Unit Price No. in the normal mode. <ul style="list-style-type: none"> • Unit Price No.1: The Unit Price No.1 is always selected when any PLU is called. • Last Unit Price: The Unit Price No. which was processed last is memorized, and it will be called when the PLU is called next time.

5.15 ERROR SETTING

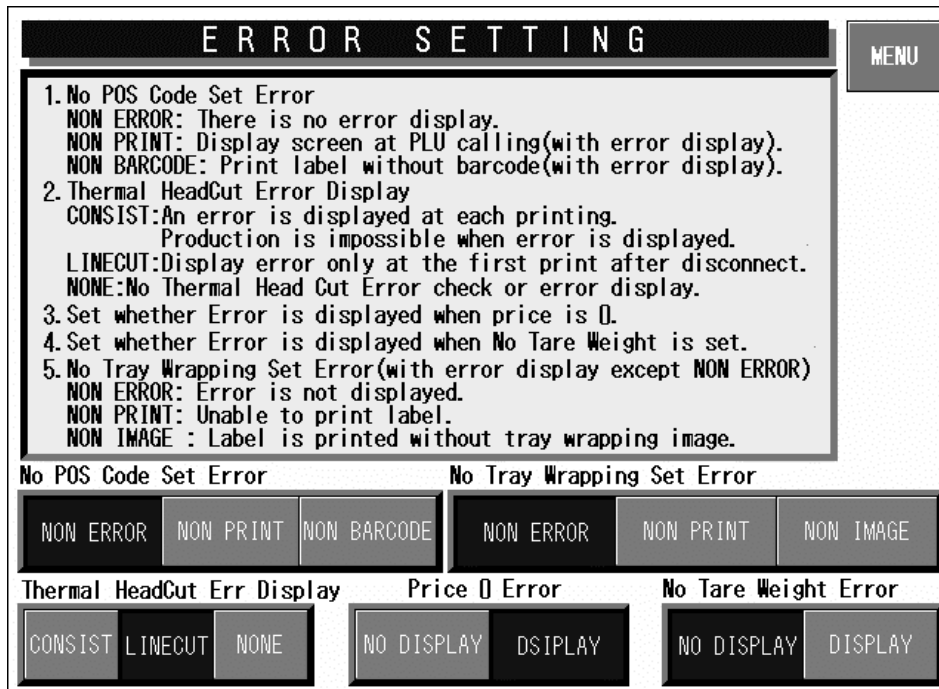

Error Setting Screen

Buttons/Display Fields	Function
MENU	Determines the settings and returns to the first screen of the Setup Menu.
No POS Code Set Error	Select one of the following items to determine the procedure when calling a PLU of which POS code is not set. <ul style="list-style-type: none"> • Non Error: No error screen appears. • Non Print: An error screen appears. When the error screen is released, calling the PLU will be canceled. • Non Barcode: An error screen appears. When the error screen is released, the barcode will be blanked on the label.
Price 0 Error	Select whether or not to display an error screen when "0" price is entered.
Thermal Head Cut Error Display	Select one of the following items to determine the procedure when a head failure occurs. <ul style="list-style-type: none"> • Consistent: An error screen always appears once a failure occurs. • Line Cut: An error screen appears when a failure occurs. • None: No error screen appears.
No Tare Weight Error	Select whether or not to display an error screen when printing is performed without tare weight setting.
No Tray Wrapping Set Error	Select one of the following items to determine the procedure when no tray wrapping is set. <ul style="list-style-type: none"> • Non Error: No error screen appears even when the tray wrapping image is not set. • Non Print: Even after the error screen is released, it appears every time until the tray wrapping image is normally set. Operation is prohibited when the tray wrapping image is not set. • Non Image: An error screen appears when the tray wrapping image is not set. After the error screen is released, it will not appear until next call.

5.16 PRINT SELECT SETTING

PRINT SELECT SETTING

MENU

1. Following Selection is effective only when barcode print on bottom label in two label printing.

Front Label BarCode Print Selection

PRINT
NO PRINT

Item Name Over Print Selection

ERR
MAX PRINT

Buttons/Display Fields	Function
MENU	Returns to the first screen of the Setup Menu.
Front Label Barcode Print Selection	This function is effective only when two labels are issued, and the bottom label type is selected to print the barcode. Select whether or not to print the barcode on the first label. (See the table below)
Item Name Over Print Selection	Select one of the following items to determine an expansion error procedure. <ul style="list-style-type: none"> • Error: Output the expansion error, and stop processing. • Max. Print: Expand to a maximum and print within the range.

■ When front label barcode is printed
(PLU master file)

Bottom Label Type	Front Label Barcode Print Selection			
	Print		No print	
	Front	Bottom	Front	Bottom
None	○	-	○	-
Barcode	○	○	×	○
Additive	○	×	○	×
Barcode + Additive	○	○	×	○
Collective display	○	-	○	-
Collective display + Barcode	○	○	×	○
Collective import	○	-	○	-
Collective import + Barcode	○	○	×	○

○: With barcode print ×: Without barcode print

■ When front label barcode is not printed
(PLU master file)

Bottom Label Type	Front Label Barcode Print Selection			
	Print		No print	
	Front	Bottom	Front	Bottom
None	×	-	×	-
Barcode	×	○	×	○
Additive	×	×	×	×
Barcode + Additive	×	○	×	○
Collective display	×	-	×	-
Collective display + Barcode	×	○	×	○
Collective import	×	-	×	-
Collective import + Barcode	×	○	×	○

6

TRAY PROGRAM

CONTENTS

6.1 TRAY PROGRAM (LABEL).....	6-2
6.2 LABEL POSITION ADJUSTMENT	6-3
6.3 TRAY PROGRAM (DETAIL)	6-4

6.1 TRAY PROGRAM (LABEL)

Tray program can be performed on the following screens in Program Mode.

Display Fields	Function
Label Position	Either standard or rotated label position can be selected.
Label Position (Horizontal/Vertical)	A desired position can be set among 8 different positions as shown on the screen.
Position Adjustment	When pressed, Label Position Adjustment screen appears for the selected position number. Label positioning and rotation angle can be adjusted. The standard label position information is displayed in each cell and the rotation angle is displayed in the middle.

6.2 LABEL POSITION ADJUSTMENT

Label Position Adjustment screen will appear when the [Position Adjustment] field is pressed.

Display Fields	Function
Label Position	The selected label position number is displayed. Key in a numeric value (1 – 8) and press this field to call a desired label position number.
Label Position Image	A tray image is illustrated in green lines. Label image that has not changed its position is illustrated in black lines. Label image that has changed its position is illustrated in red lines.
Clockwise Rotate	A rotating angle for label position can be set. The angle can be “0”, “90”, or “-90”.

As soon as a tray is placed on the in-feed platter, the machine will start its operation, and the label position can be visually checked.

6.3 TRAY PROGRAM (DETAIL)

Detailed Tray Program screen will appear when the [DETAIL] button is pressed.

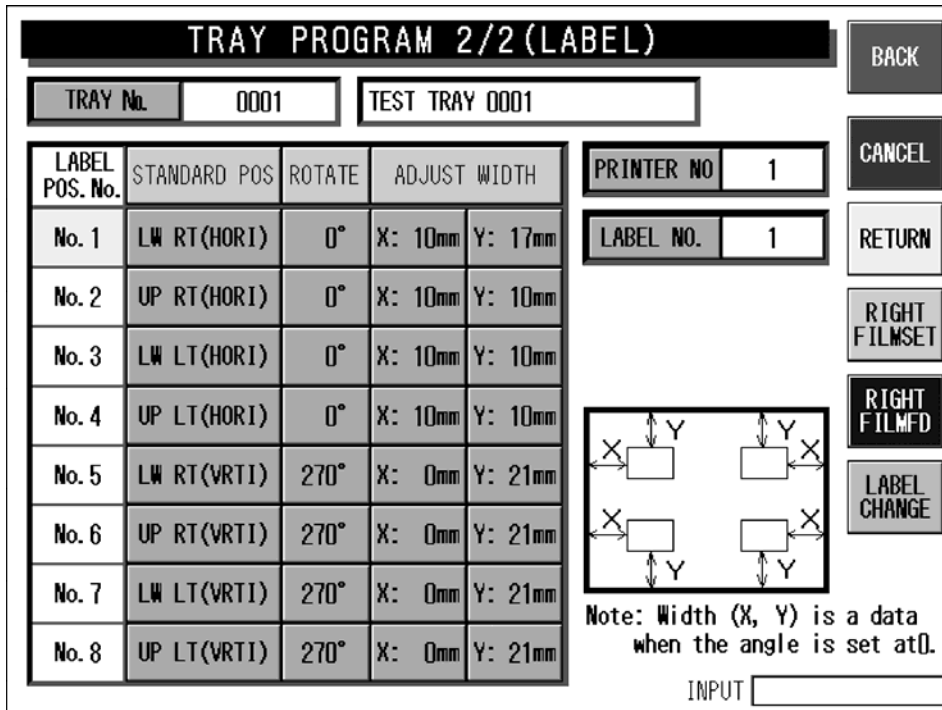

Display Fields	Function
Tray Position No.	Eight different tray position numbers are displayed. The selected area is displayed in yellow.
Standard Position	Four positions are allocated for each horizontal and vertical labeling. A pop-up screen appears when this field is pressed. Selection can be made on this screen.
Rotate	A rotating angle for each label position number is displayed. Key in a numeric value and press this field to set a desired angle.
Adjust Width	Adjustment width (mm) for each X and Y position registered for each label position number is displayed. Key in a numeric value (max. 999mm) and press this field to set a desired width.

As soon as a tray is place on the in-feed platter, the machine will start its operation, and the label position can be visually checked.

7

LABEL ADJUSTMENT

CONTENTS

7.1	LABEL GUIDE WIDTH ADJUSTMENT	7-2
7.2	LABEL SENSOR POSITION CHANGE	7-3
7.3	G. ROLLER/LABEL PRESS BRACKET POSITION ..	7-4
7.4	PRINTING ADJUSTMENT	7-6
7.5	FEEDING STOP AMOUNT	7-8
7.6	LABEL EDGE CUTTING	7-9
7.7	LABEL STANDBY PART	7-10
7.8	PEEL SENSOR OPTICAL AXIS ADJUSTMENT	7-13
7.9	HEAD-UP SENSOR ADJUSTMENT	7-14

7.1 LABEL GUIDE WIDTH ADJUSTMENT

The label position is the center reference. Change the guide positions described below depending on the label width to be applied. For use in the label width 71mm - 80mm, turn the stepped collar inside out, switch the order of the roller guide and the guide label, and add the plain washer.

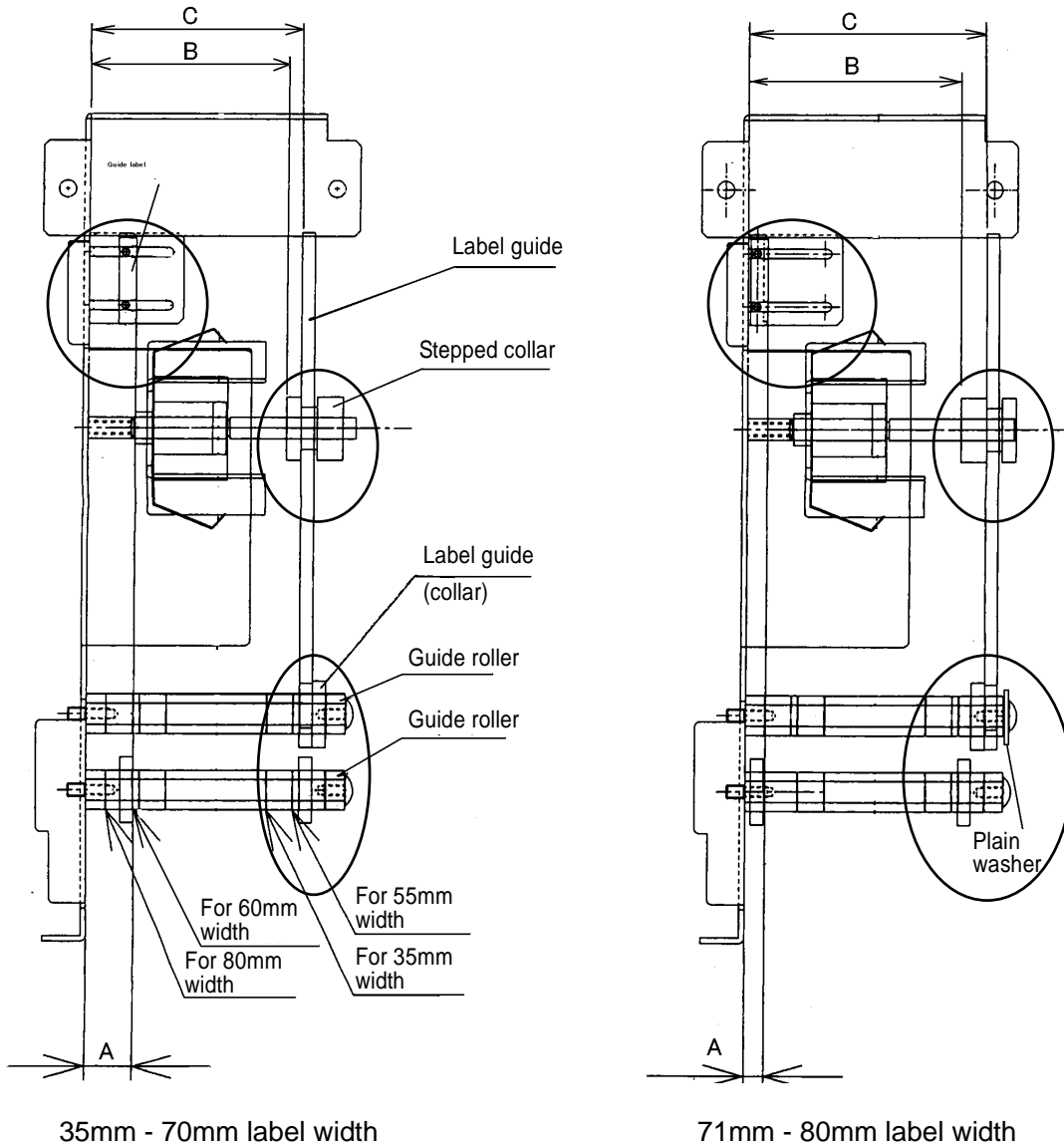

Label width	A	B	C
35mm	30.0mm	62.0mm	67.5mm
55mm	20.0mm	72.0mm	77.5mm
60mm	17.5mm	74.5mm	80.0mm
80mm	7.5mm	80.2mm	90.0mm

7.2 LABEL SENSOR POSITION CHANGE

Depending on the label size (length and gap) the number of preliminary feeling increases to meet the prescribed position when the label gap stops at the label sensor position. A label size error might sometimes occur at regular use.

To avoid this issue, reinstall the sensor to either to the front or rear position that is further than the other one if the label gap overlaps with the label sensor.

Pitch size is 5mm.

Whenever the change takes place, change the label sensor pitch to -5mm when installed in the front position, and +5mm when installed in the rear.

1. Install the label sensor horizontal to the frame and make sure it functions smoothly.
2. Ensure that the label sensor does not move much when printing labels.

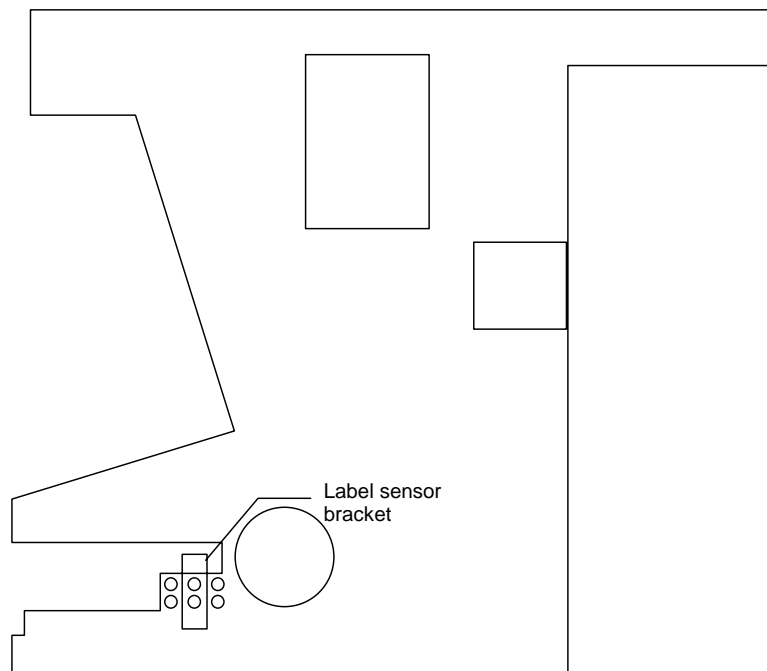

7.3 G. ROLLER/LABEL PRESS BRACKET POSITION

In a stand-by condition, the labels tend to curl up when the rear end of the label meets the roller guide, and come off above the peel shaft before the applicator adsorb them after printing. The installation position is determined by the formula based on (Label top/bottom sizes) + (Label gap). Change the installation positions (5mm intervals) depending on the label top/bottom sizes.

Standard Printer Label Position before Shipping

- Printer#1: "A" position (Label size 60 x 37 Label gap 2.2mm)
- Printer#2: "B" position (Label size 60 x 55 Label gap 3.0mm)

When changing the label size, change the guide roller and label retainer bracket as well.

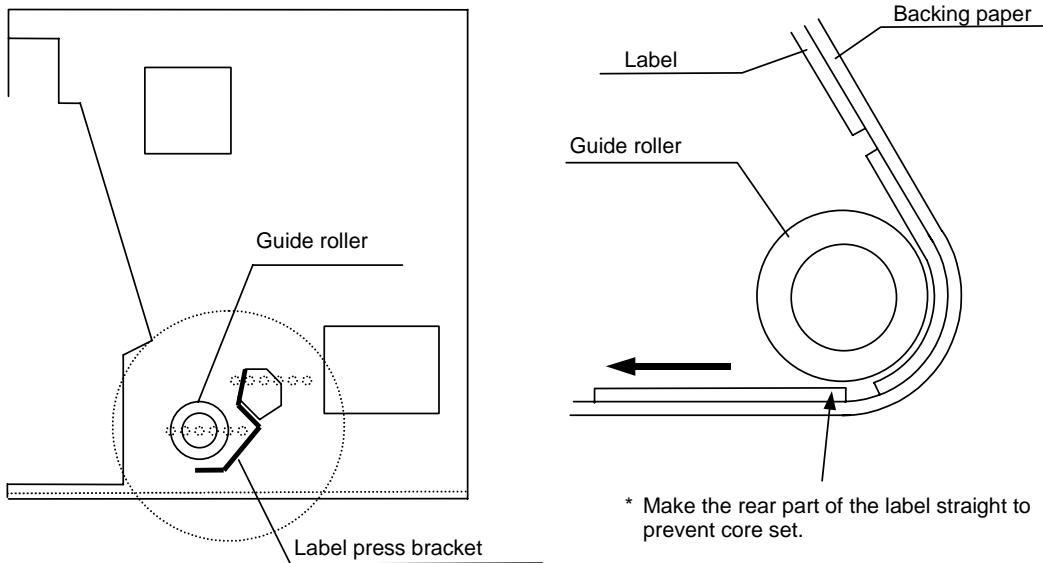

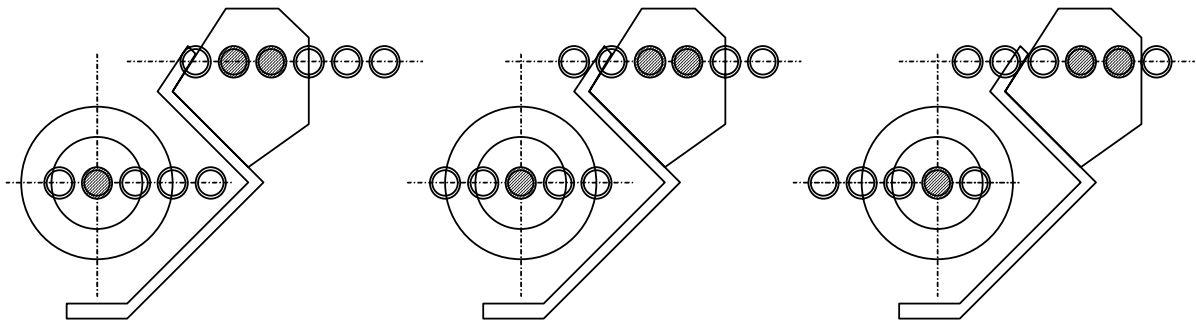

A
Label top/bottom size 37mm
Label gap 2.2mm

- B { Label top/bottom size 42mm
Label gap 2.5mm
- C { Label top/bottom size 55mm
Label gap 3.0mm
- D { Label top/bottom size 58mm
Label gap 3.0mm

C
Label top/bottom size 60mm
Label gap 2.5mm

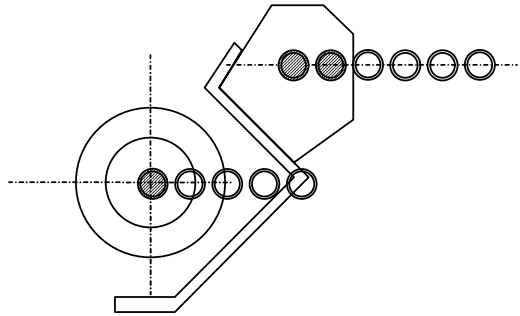

D
Label top/bottom size 38mm
Label gap 2.0mm

Set the actual label for use, and confirm the label gap position after several preliminary feedings.

7.4 PRINTING ADJUSTMENT

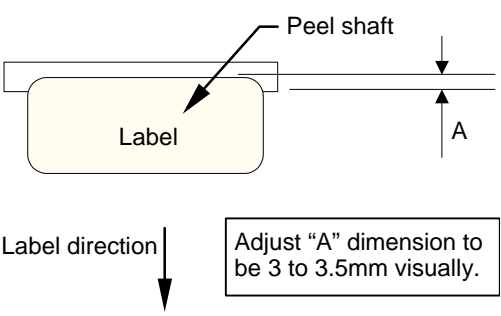
Adjusting Items	Procedures	Criteria for adjustment
Check printing <ul style="list-style-type: none"> Label sensor distance Test label length Gap length Front feeding amount Front feeding stop amount Printing right/left positions Printing quality Printing positions Print inclination 	<ol style="list-style-type: none"> Start with the printing adjustment mode of the test mode. Press the Checkerboard and Back Feed keys. Input the actually measured label and gap lengths. The standard label sizes are: Printer #1: 60mm(W) x 37mm(L) Gap length 2.2mm Printer #2: 60mm(W) x 55mm(L) Gap length 3.0mm Front feeding amount: 7.5mm Set the print density to "5". Press the Preliminary Feed key several times. (about 5 times) Press the Print key. 	<ul style="list-style-type: none"> Adjust the print position so that the label printing meets the ruled line. For the pre-feeding amount, adjust the label printing position to the position described below after printing the labels. (Refer to Exhibit and the following diagram.)  <ul style="list-style-type: none"> The print density of the printed pattern (checkerboard) should be entirely clear and bisymmetric. Adjust the right and left positions of the label. (For the right/left reference line, it is considered acceptable if more than one out of ten labels is printed within the label.) Check the print inclination with eyes and adjust it within $\pm 0.3\text{mm}$. It is considered acceptable if more than 2 labels come off from the peel shaft. (Refer to Exhibit "How to confirm edge cutting.") The head does not come off with its head lever being released.
<ul style="list-style-type: none"> Confirm edge cutting Head opening/shutting check 	<p>Input 7.5mm as the pre-feeding stop amount, and print 10 labels.</p> <p>With its head being set, try to pull out the inner frame slightly several times.</p>	<ul style="list-style-type: none"> Input 7.5mm as the pre-feeding stop amount, and print 10 labels. With its head being set, try to pull out the inner frame slightly several times.

* If any adjustment was made after confirming the edge cutting, adjust the front feeding amount again.

* When adjusting the pre-feeding volume, the label printing position (the ruled line) can be the reference, however, the printing is not always output 7.5mm below the label bottom due to the printing precision problems.

CHECK ITEMS

Item	Working method
Unclear printing Uneven print density for the left and right	Detach the head cover, loosen the screw of the print bracket, and adjust the position of the thermal head in relation to the print roller.
Print inclination	Detach the head cover, loosen the screw of the print bracket, and adjust the inclination of the thermal head.
When the right and left print positions are misaligned.	Adjust the guide roller position of the printer.
Pre-feeding stop amount	Change the pre-feeding numerical value for the mode of print adjustment. (Reference value: 3.8mm for the first printing, and 3.5mm for the 2 nd printing.)
Edge cutting	In an automatic application specification, the priority is placed on edge cutting. Change the numerical value of the label sensor distance for the mode of print adjustment. (After the adjustment is made, printing can be misaligned in relation to the item line and ruled lines on the label. This is attributed to the problem of print precision, and ask the label supplier for correction. If you have no choice but to use the label, align the printing position by adjusting the coordinates of the label format. Ref.: As the numerical value of the label sensor distance becomes greater, the entire printing shifts upwardly in relation to the label. (Refer to the label sample shown below.)
Check the head change	Adjust the lengthwise position of the inner frame when it is installed. Detach the head cover, loosen the print bracket screw, and readjust printing.

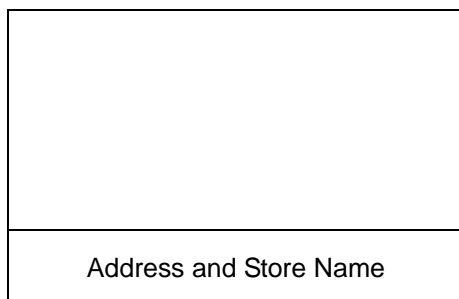

Distance for the Label Sensor
(Regular Sample)

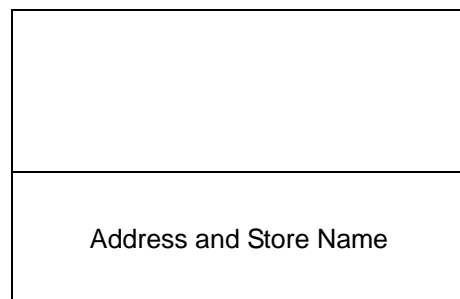

Greater Distance for the Label
Sensor

7.5 FEEDING STOP AMOUNT

Set the value for the front feeding stop amount between C_{min} – C_{max} , and adjust C depending on the degree of exfoliation of the label from the base paper.

C_{min} : Front feeding stop amount (mm) = B (9.5mm) – A (3.0mm) - gap length

C_{max} : Front feeding stop amount (mm) = B (9.5mm) – A (3.5mm) - gap length

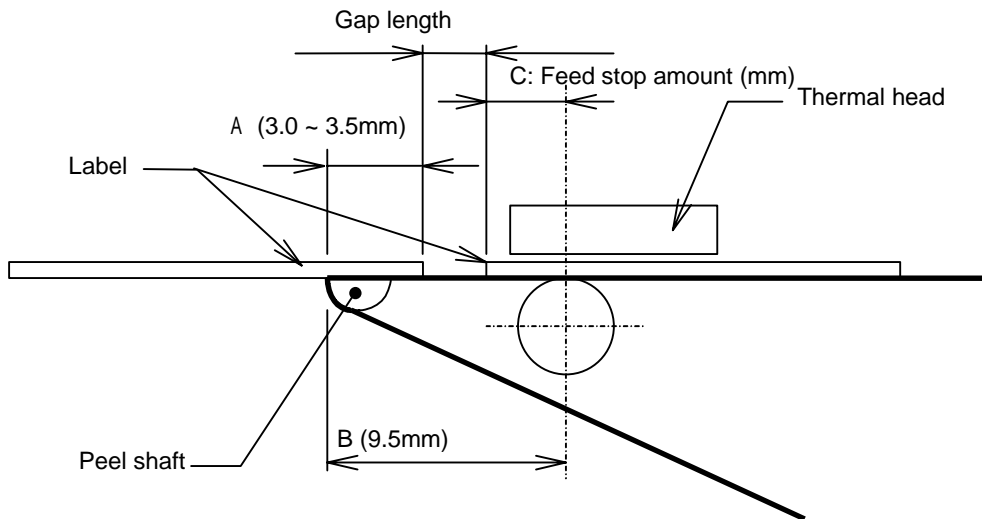

Adjustment of label feeding stop amount

7.6 LABEL EDGE CUTTING

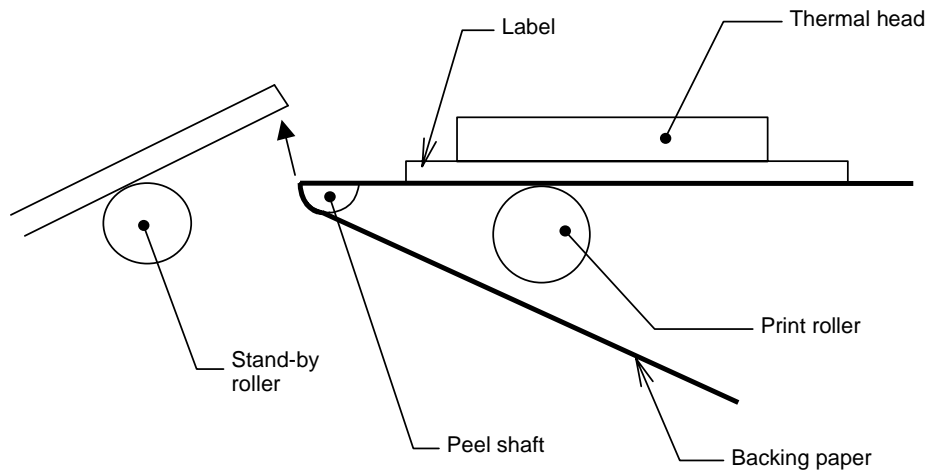

Set the value of feeding stop amount and feeding amount equally. It is acceptable if the label falls down to the lower part as shown in the fig. (The label might not fall down after the repetitive process in regard to the print precision and the paste condition, but it is still within the acceptable range.) At this point, check if the label is sent forth to the point where the label is peeled off. Adjustment can not be performed if the edge cutting is not good, and the adjustment is not necessary for manual pasting.

7.7 LABEL STANDBY PART (AUTOMATIC APPLICATION ONLY)

7.7.1 STANDBY ROLLER HEIGHT ADJUSTMENT

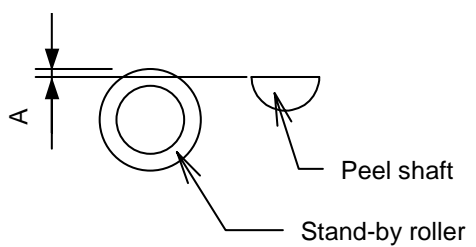
Procedures	Adjustment Criteria
<ol style="list-style-type: none"> 1. Start with the printing adjustment mode of the test mode. 2. Press the Checkerboard and Back Feed keys. 3. Press the preliminary feeding key several times. (about ten times) 	<ul style="list-style-type: none"> • Adjust it so as not to issue defective labels due to the labels touching the standby roller. • Adjust the standby roller height to the level shown in the fig. below. <div style="text-align: center; margin: 10px 0;">  <p style="margin: 0;">"A" dimension (top of the peel shaft and top of the roller) is 0 to 0.5mm</p> </div> <ul style="list-style-type: none"> • Adjust the peel shaft and standby roller positions parallel to each other.

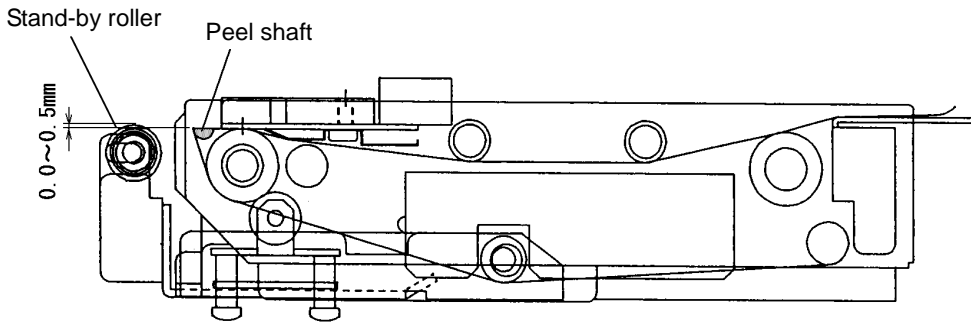

7.7.2 STANDBY ROLLER POSITION ADJUSTMENT

To improve the label retain ability, adjust the position of the roller in the standby segment depending on the length of the label.

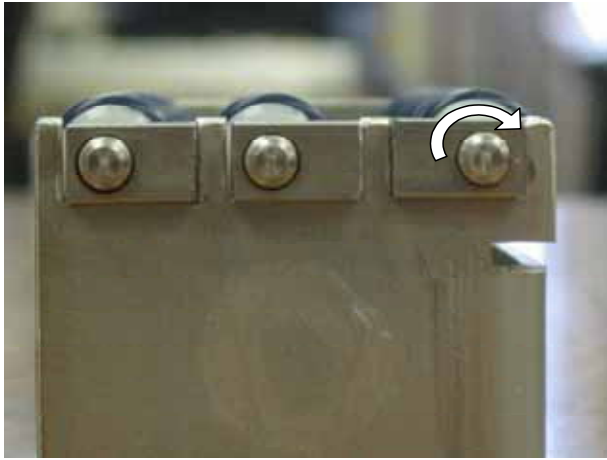

Rotate the block to adjust the roller position.

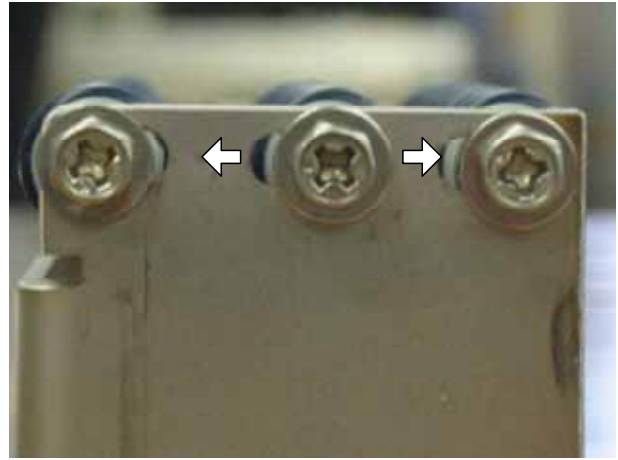

Slide the screw left or right to adjust the roller position.

7.7.3 ROLLER ALIGNMENT CHANGE

When both the right and left label edges locate either on the roller slope or front edge, misalignment of the label or adsorption failure might be caused as both ends get stuck in the roller during the label feeding. Make necessary changes depending on the label width and the number of collars (3mm in width) between the rollers.

35mm of width of label, 60mm, and 80mm

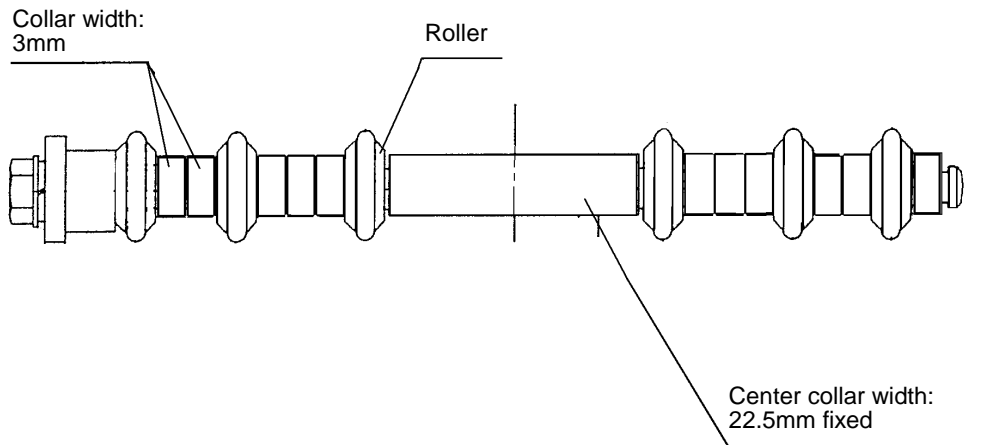

55mm in width of label

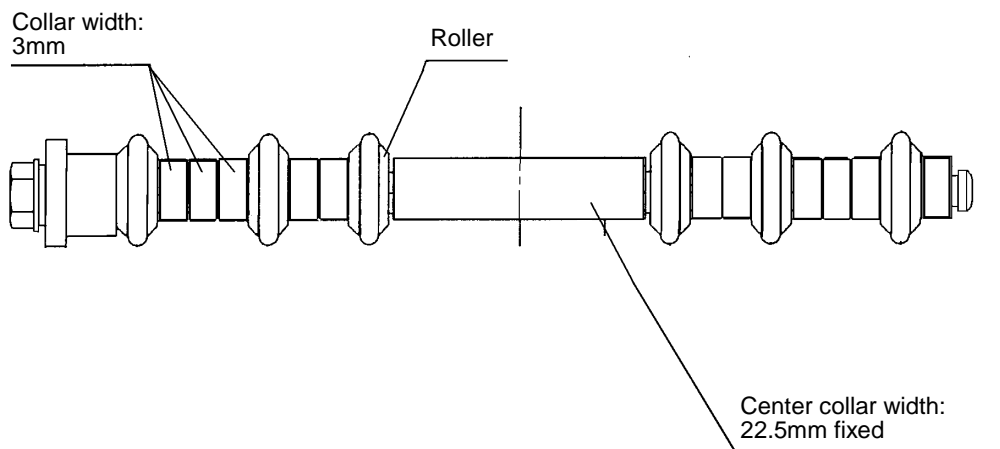

7.8 PEEL SENSOR OPTICAL AXIS ADJUSTMENT

Adjust the peel optical axis to be within 3 – 5mm from the front end of the peel shaft.

When the label is printed, adjust the rear end of the label top/bottom to make the peel sensor level within 10 in the optical axis segment shown in the fig. below.

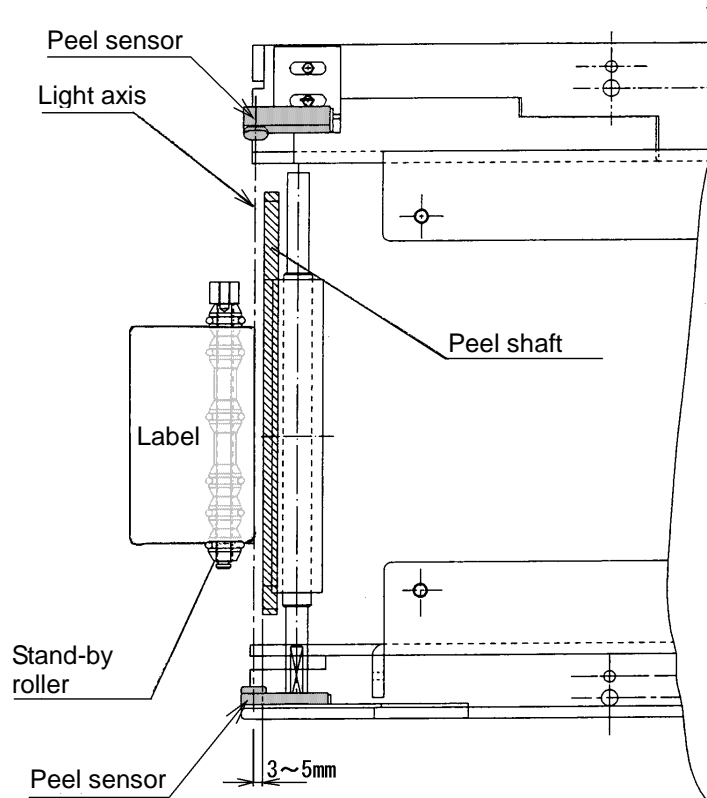

7.9 HEAD-UP SENSOR ADJUSTMENT

Adjust the gap to be 2 to 3mm as shown in the fig. below with the printer surely locked.

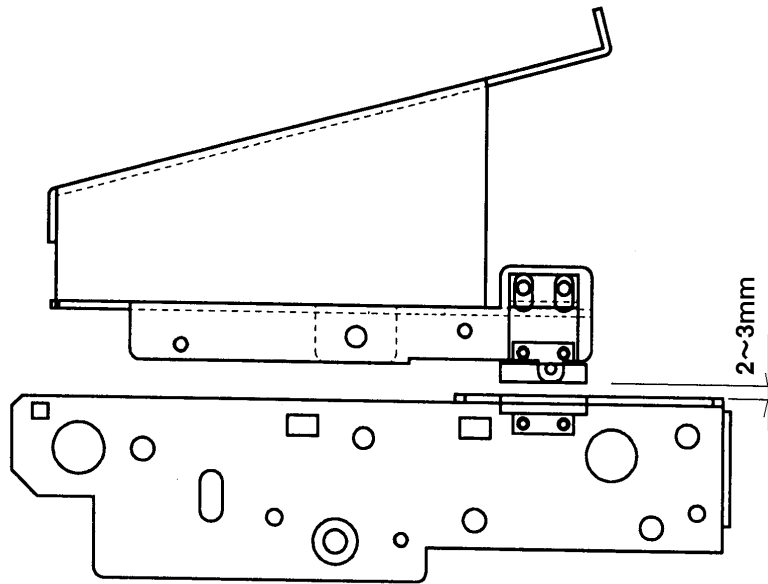

8

LOAD CELL UNIT

CONTENTS

8.1 MAIN PARTS 8-2
8.2 LOAD CELL UNIT REPLACEMENT 8-3
8.3 SPAN ADJUSTMENT 8-6

8.1 MAIN PARTS

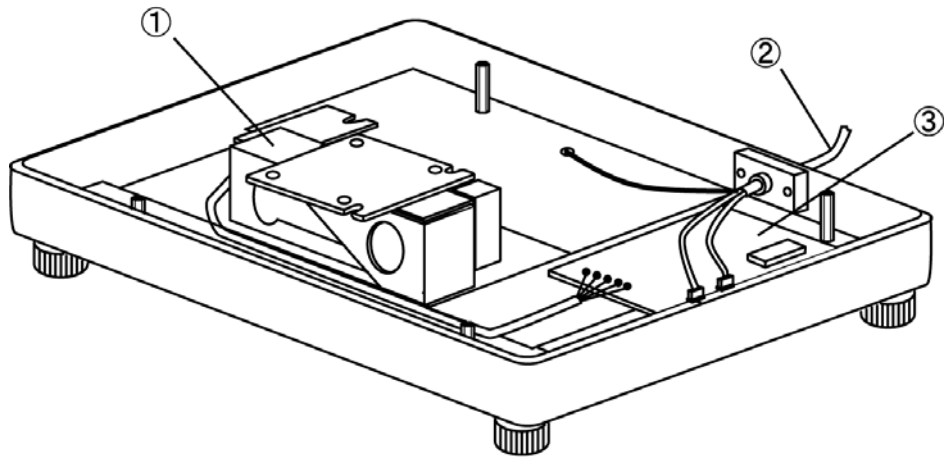

Location of main parts

No.	Part Name
1	LC unit CLC-25N
2	Harness C3' scale 1
3	A/D board PWB' 830

8.2 LOAD CELL UNIT REPLACEMENT

8.2.1 INFEED AND ROLLER UNITS

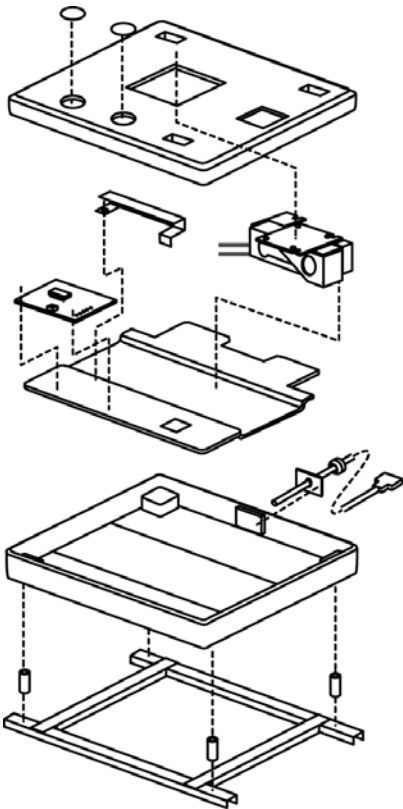

Infeed unit

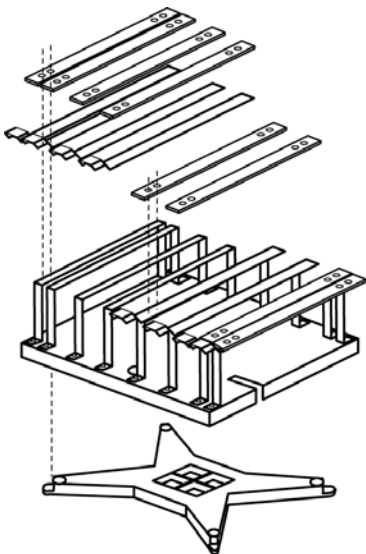

Roller unit

8.2.2 WEIGH PLATTER

1. Cut the seal wire.
2. Loosen the seal screws #1 and #2, and remove the weigh platter.

⚠ CAUTION

Do not cut the base seal wire if not required since it is necessary to replace the sanction seal when the seal wire is cut.

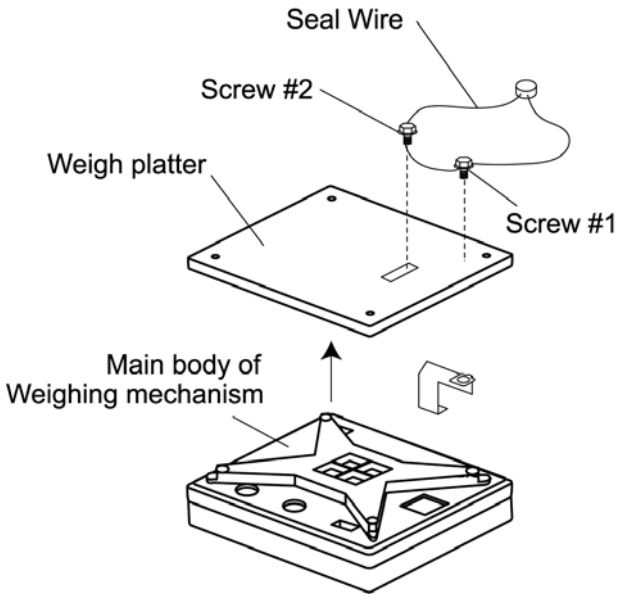

Seal wire and weigh platter

8.2.3 PLATTER SUPPORT

1. Loosen the four (4) screws holding the platter support.

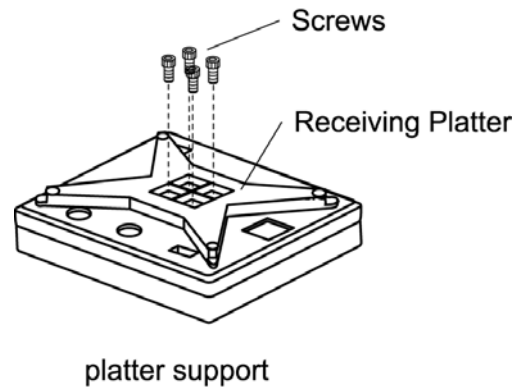

8.2.4 WEIGH MECHANISM COVER

1. Loosen the screw located underneath the seal.
2. Lift the weigh mechanism cover slowly.

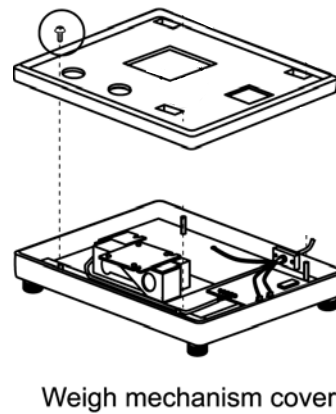

8.2.5 A/D BOARD

1. Disconnect the connector #1 and #2 from the A/D board.
2. Remove the A/D board locking support (4 locations).
3. Remove the load cell connection cable soldering (5 locations).

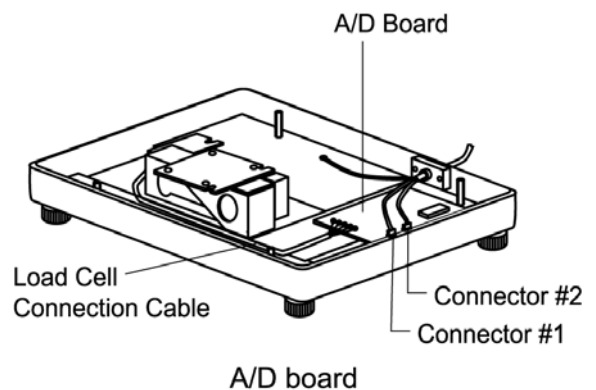

8.2.6 LOAD CELL UNIT

1. Loosen the load cell unit screws (2).
2. Remove the load cell unit.
The load cell output cable is soldered to the board.

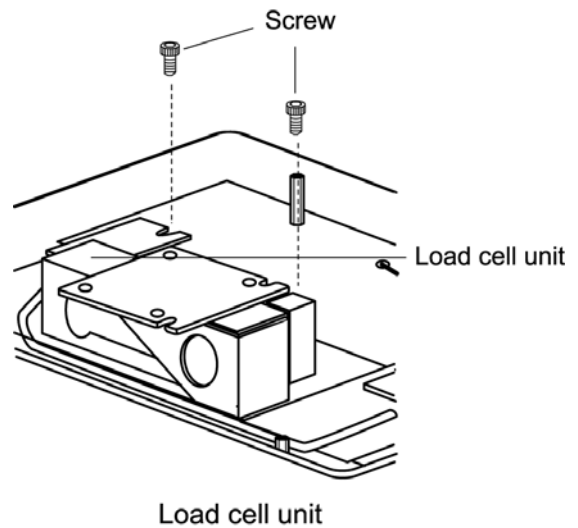

3. Be careful not to mistakenly connect the wrong wires when soldering the load cell cables.

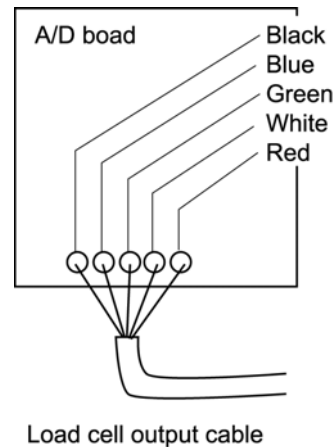

8.2.7 FOUR-CORNER LIMIT POSITION

- With the roller unit, weigh platter, and platter support installed, adjust and confirm the position of the four-corner limit screws.
- The four-corner limit screws are designed to protect the load cell from being damaged when excessive load is applied to the weigh platter.
- Adjustment of the four-corner limit screws is required when the load cell was replaced or the main body was jolted.

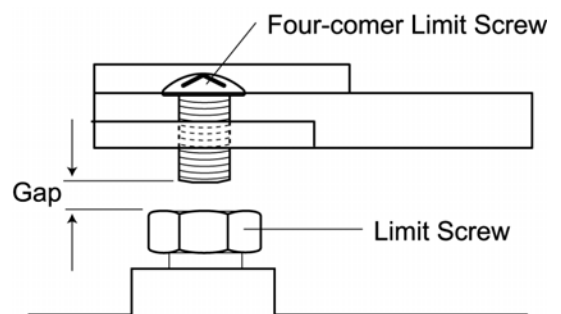

8.3 SPAN ADJUSTMENT

8.3.1 ADJUSTMENT PROCEDURE

Span adjustment is performed in test mode. Refer to "Test Mode" for the starting test mode procedures.

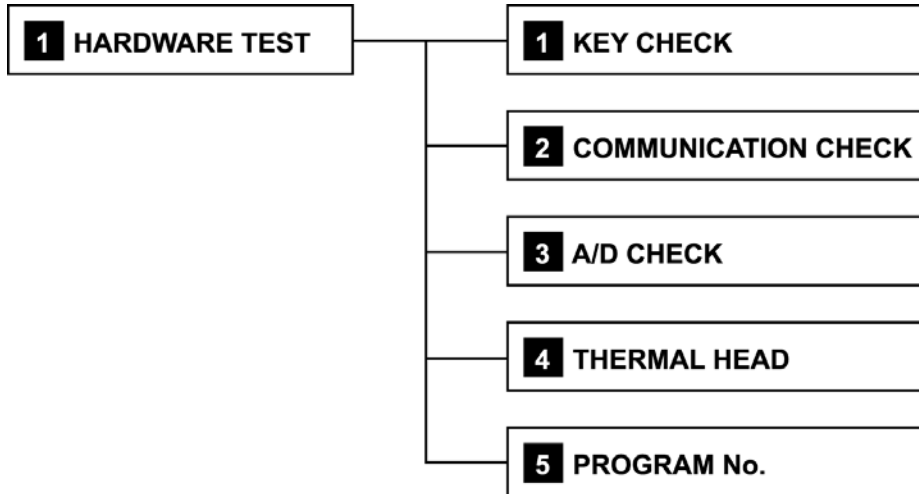

8.3.2 SPAN ADJUSTMENT FLOWCHART

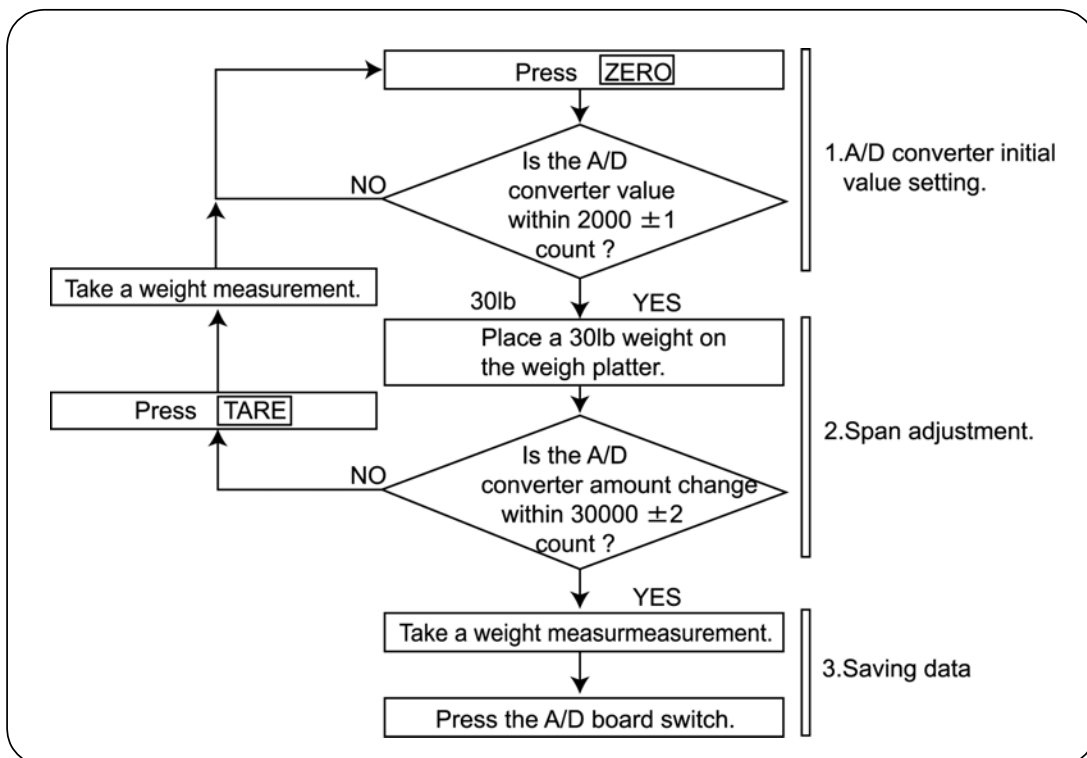

1. A/D Converter Initial Value

- Press **[ZERO]**.
- The A/D converter initial value is displayed in the unit price column.
- Check that the initial value is within 2000 ± 1 count.
- If it is within 2000 ± 1 count, perform span adjustment.
- If it is not within 2000 ± 1 count, press **[ZERO]**.

2. Span Adjustment

- Place an item weighing 30lb on the weigh platter.
- The A/D converter weight change is shown in the weight column.
- Check that the span adjustment is within 30000 ± 2 count.
- If it is within 30000 ± 2 , save the data. If span adjustment is not within 30000 ± 2 count, press either the **[TARE]** or **[SPAN]** button to take a weight measurement.
- Repeat procedures beginning with "1. A/D converter initial value".

*Note: When SPAN is positioned at 30lb, continue to press the **[30000]** button until the counter reaches to **[37500]**. Refer to A/D check in Test Mode.*

3. Saving the data

- Save the data to E 2 ROM.
- Remove the weight from the platter and then remove the platter.
- Remove a seal and press the switch from the top.

4. Removing load cell unit

- Turn off power to finish span adjustment.

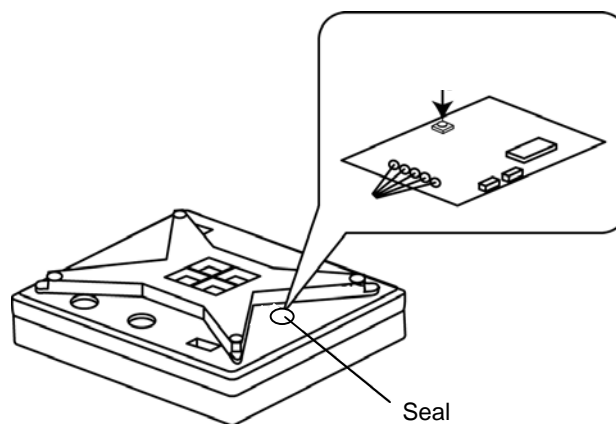

Disconnecting power

⚠ CAUTION

Do not touch the switch with a screwdriver or any other metallic objects.
Do not cut the base seal wire if not required since it is necessary to replace the sanction seal when the seal wire is cut.

9

WRAPPING KNOWLEDGE

CONTENTS

9.1	TRAY PUSHER SPEED	9-2
9.2	APPROPRIATE FILM WIDTH.....	9-2
9.3	WRAPPING SPEED	9-2
9.4	SENSOR ORIGIN POSITION ADJUSTMENT	9-3
9.5	TRAY SURFACE FILM TENSION ADJUSTMENT	9-4
9.6	SETTINGS TRAY WIDTH AND LENGTH	9-5
9.7	ADJUSTMENT OF SENSOR ORIGIN POSITION	9-6
9.8	SELECTION OF FILM WIDTH.....	9-7
9.9	ADJUSTMENT OF LIFT HEAD HEIGHT	9-8
9.10	FILM PINCH SOLENOID POSITION ADJUSTMENT	9-10

9.1 TRAY PUSHER SPEED

Example: Width = 28cm; Length = 22cm

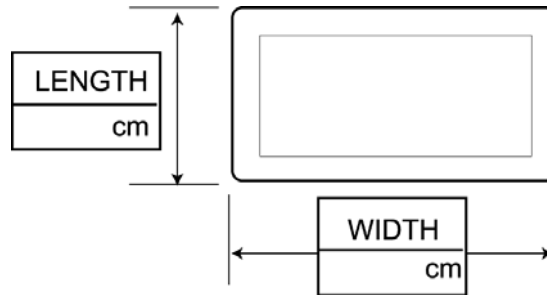

The default setting for the pusher speed is "45". In this case, the tray is 26cm long.

Length	20cm	21cm	22cm	23cm	24cm	25cm	26cm
	↓	↓	↓	↓	↓	↓	↓
Speed	51	50	49	48	47	46	45

9.2 APPROPRIATE FILM WIDTH

The appropriate film width can be obtained by adding 4cm to the tray circumference.
 Example: Length = 22cm, Height = 3cm makes $22\text{cm} + 22\text{cm} + 3\text{cm} + 3\text{cm} = 50\text{cm}$
 For this dimension, the 54cm film is most appropriate.

9.3 WRAPPING SPEED

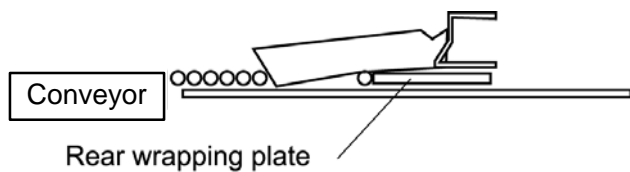

The pusher pushes the tray when the rear wrapping plate does not reach its limit. If the wrapping is performed at this point, the tray will be crushed forward.

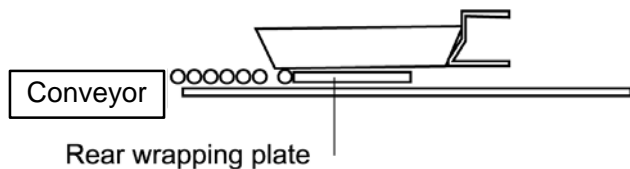

The pusher pushes the tray smoothly if the rear wrapping plate reaches its limit.

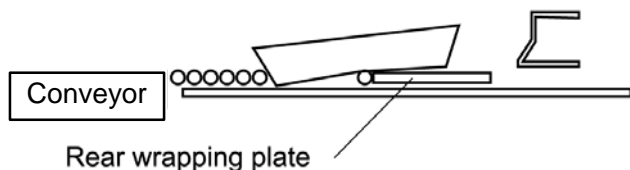

Adjust the volume to delay the timing of the pusher. The pusher pushes the tray when the rear wrapping plate reaches its limit.

Note: Applicator position must be adjusted again after the pusher volume adjustment was made.

9.4 SENSOR ORIGIN POSITION ADJUSTMENT

When OMNi-4000ST is shipped out from the Ishida factory, it is adjusted to the Ishida's original tray. So it needs to be readjusted to match the customer's tray.

It is better to adjust the tray as much closer as possible to the edge of the discharge roller.

- Adjusting the sensor origin position (Clearance (1): Ex-factory standard adjustment) the sensor position can be adjusted to place the tray closer to the discharge roller area. When adjusting the position, select the longest tray.
The sensor origin position should be adjusted without crashing the tray and the tray comes much closer to the edge of the discharge roller (Clearance (1) to Clearance (2)).
- When adjusting the position, please set STOP POSITION of TRAY PROGRAM 1/2 as BACK (default = FRONT: refer to Chapter 5.12 TRAY FILE, page 5-47).
- When above adjustment is completed, please check if all other trays can be wrapped properly. In this case, please set back STOP POSITION of TRAY PROGRAM 1/2 as FRONT.

Note: The other trays may be crashed while checking, or the message "No item" appears. In this case, please set STOP POSITION as BACK. If the error still occurs, please adjust the sensor origin position again using the tray.

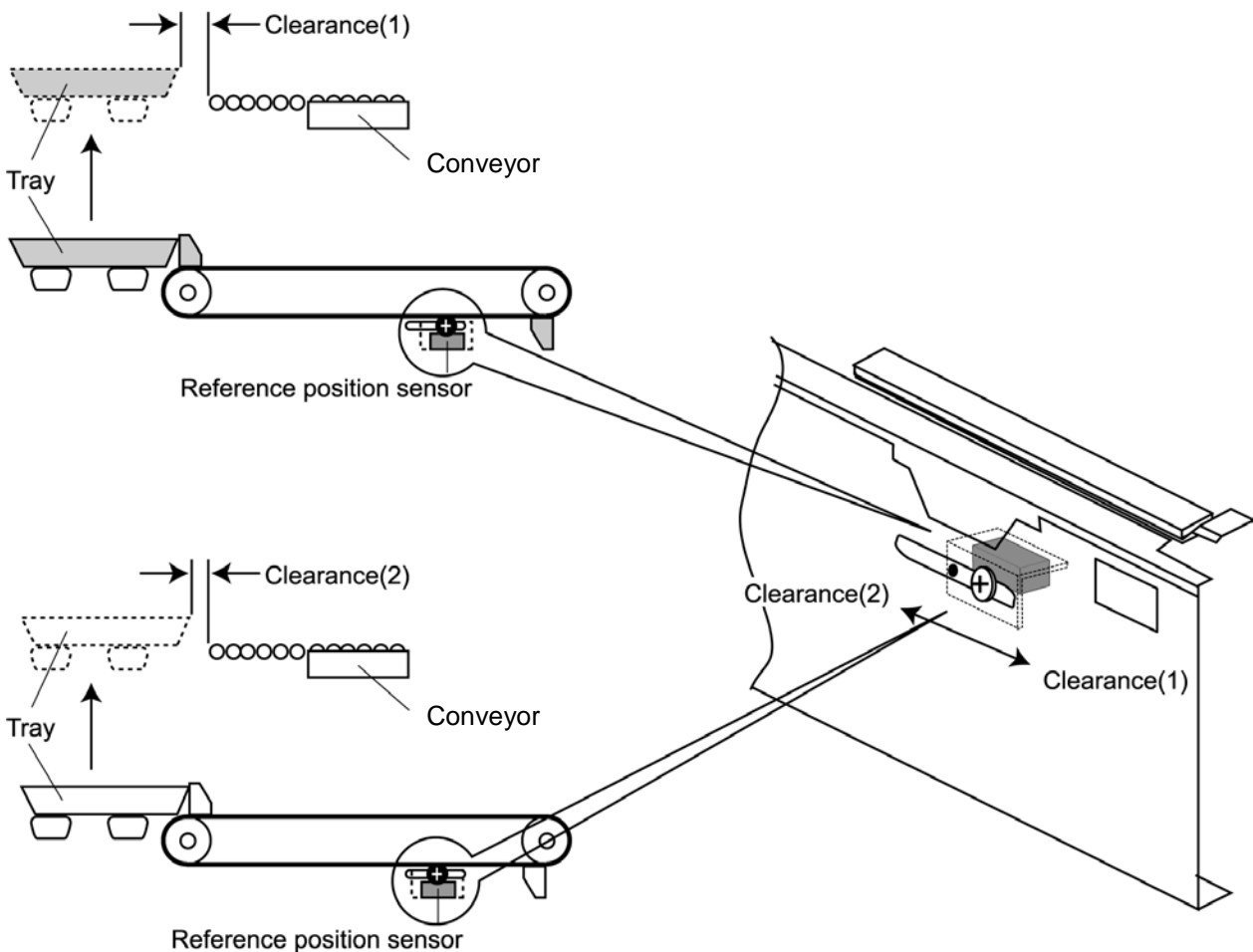

9.5 TRAY SURFACE FILM TENSION ADJUSTMENT

Adjust the overall film tension of the tray surface using the [+] and [-] buttons. The film tension can be adjusted by adjusting the movement timing of the rear wrapping plate, left and right wrapping plates, and the pusher as well as the solenoid strength.

Film tension can be adjusted by changing the clumping time. Increasing a value will make clumping time longer, tension will be increased when wrapping plates fold film.

Rear tension
0
+ -

← Adjust the rear tension using the solenoid.

The rear tension of the tray can be adjusted by using the rear wrapping plate.



Side tension
0
+ -

← Adjust the tension of the tray side surface using the solenoid.

The tension of the tray side surface can be adjusted by using the side wrapping plate.



Front tension
0
+ -

← Adjust the front tension of the tray using the solenoid.

The rear tension of the tray can be adjusted by using the rear wrapping plate.



The difference between rear tension and side tension may not exceed three. Adjust it by changing the setting for the tray length and width.

9.6 SETTINGS TRAY WIDTH AND LENGTH

Start timing of wrapping plates can be programmed by entering the tray length and width. The timing of the rear wrapping plate and side wrapping plates slightly differs depending on the machine when the tray size is set as "19" or "20", such as "19.5cm".

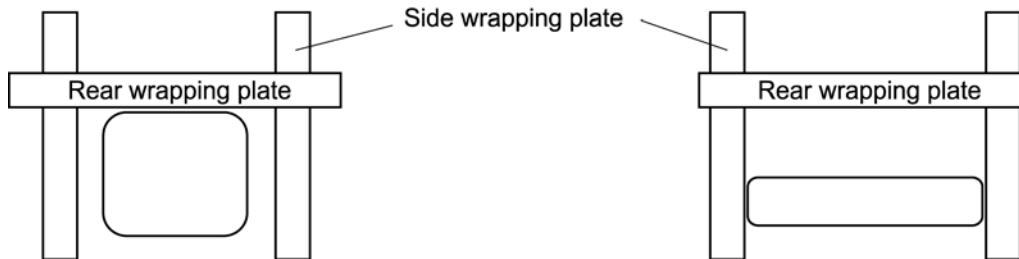

Side wrapping plates reach slightly earlier than rear wrapping plate.

Side wrapping plates reach the tray faster than the rear wrapping plate.

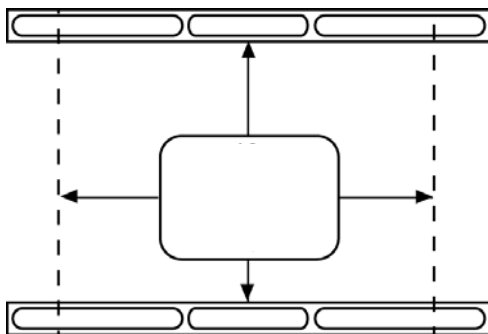

When adjusting, adjust it not only by setting the solenoid clumping time but also by changing the tray dimensions.

9.7 ADJUSTMENT OF SENSOR ORIGIN POSITION

This has to be done according to customer's requirements (At the time of shipment from the factory, it is set to a position where all types of trays can be accommodated).

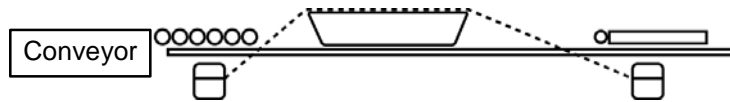

The film length between the front and rear does not differ because the tray is raised too early. This makes it difficult for the rear wrapping plate to be inserted under the tray and causes the tray to be hit by the plate.

This will also occur when an inappropriate film width is selected.



The rear wrapping plate is easily inserted because the rear side of the tray raises as the tray is lifted towards the discharging roller.

- “Sensor position”: To be adjusted to lift high or fragile trays.
- Set the sensor origin position to lift trays when they come close to the discharging rollers. When an inappropriate film width is selected, smooth wrapping might not be carried out even after adjustments have been performed.

9.8 SELECTION OF FILM WIDTH

How to better select film width is described in the previous item 1. Is it possible to select the width by only imagining the wrapped condition? You may think that it is "OK" because the film is overlapped 1cm, but you have to take the strength of the tray into consideration as well.

There are various problems such as broken trays, the film was not folded into the rear side of the tray and so on.

The illustrations below show what the film length causes.



The wrong film width was selected. The film length at the rear and front are almost the same.

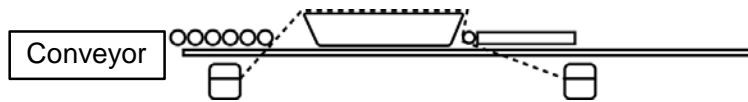

The rear wrapping plate cannot be inserted because the film at the rear side cannot be stretched. If it cannot be stretched, the tray is pushed down by the rear wrapping plate.



A correct film width is selected. The film length at the rear is longer than that of the front.



The rear wrapping plate can be easily inserted under the tray because the film at the rear can be stretched.

9.9 ADJUSTMENT OF LIFT HEAD HEIGHT

Lift head height must be adjusted according to the shape of the tray bottom.

(At the time of shipment from the factory, the head height is set not lower than the surface of the rear wrapping plate.)

- Wrapping conditions must be adjusted by selecting a correct film width, tray lifting position, tray size and the solenoid strength. A trouble should not be removed only by raising the lift head height when a tray is damaged.
- Lift Head Height

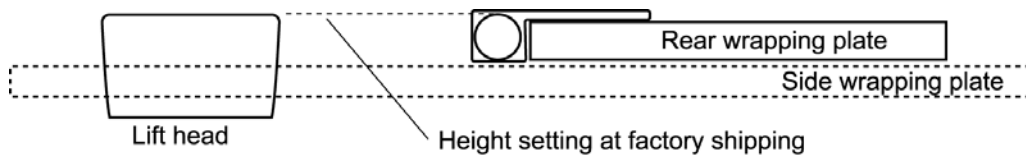

The above figure shows the setting condition when the machine is shipped out from factory.

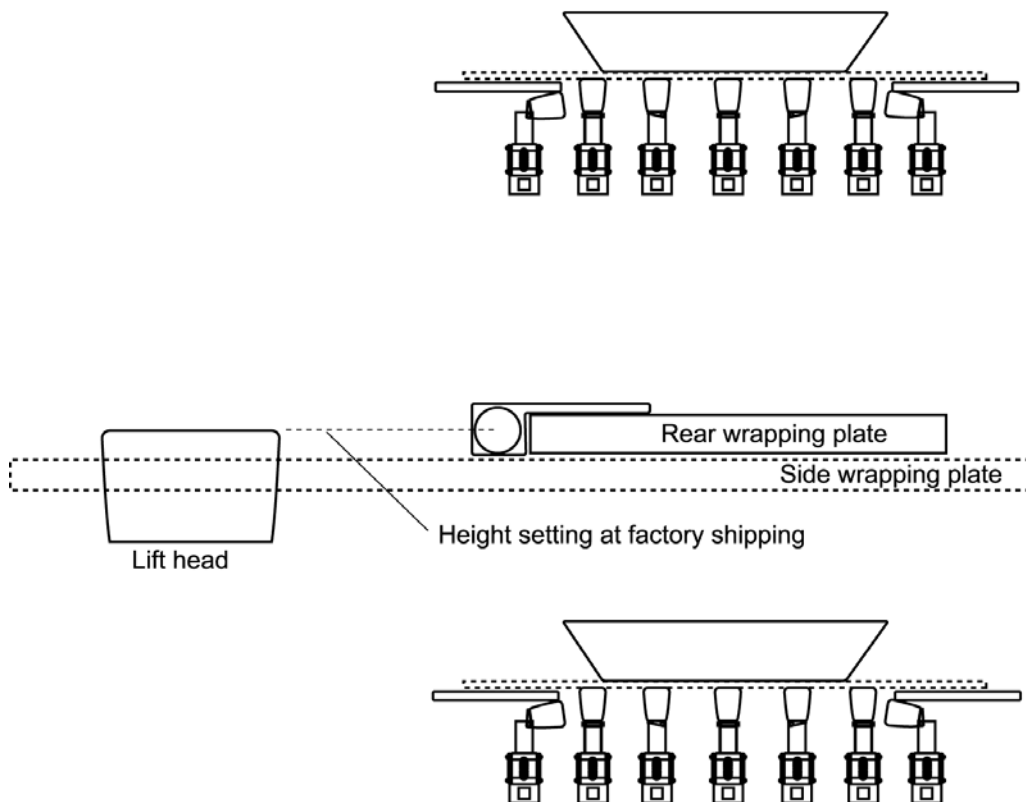

Find and set the best positions after carrying out wrapping tests for each tray type. The positions will differ depending on strength and shape of the tray.

When the lift head is set too high and/or the film is too wide.

Usually, the lift head height is higher than the surface of the rear wrapping plate by 5mm or so. Lift heads are pushed down by the rear wrapping plate moving forward, and the tray comes down on the plate. In this case, film tension gets loosened at the front of the tray, side and tightened at the rear side.

If the lift head is set too high (A), the tray is pushed onto the discharging rollers (C) by the rear wrapping plate (B) and the film from the rear cannot be folded underneath the tray bottom.

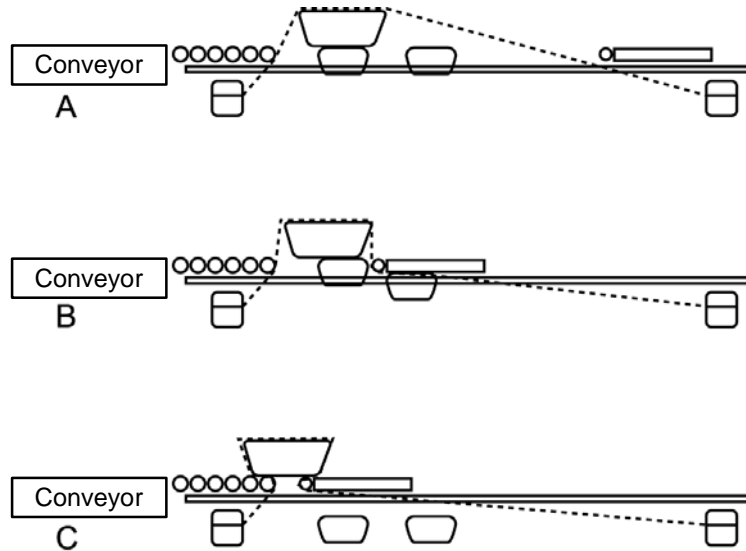

When the lift head height is appropriate, the film at the rear is properly folded under the tray bottom (D) because the tray is not pushed onto the discharging rollers.

If the film is too wide, the film at the rear will become too loose to be folded under the tray bottom.

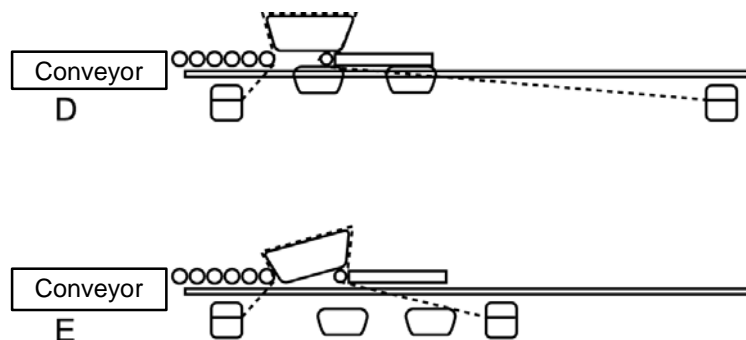

9.10 FILM PINCH SOLENOID POSITION ADJUSTMENT

1. Remove the bottom cover of the feeder.
2. Push the bracket in the direction shown in the following illustration while pressing the link resin toward the clamp plate, and return the bracket 1-3mm from the place where resistance is felt and fix it.

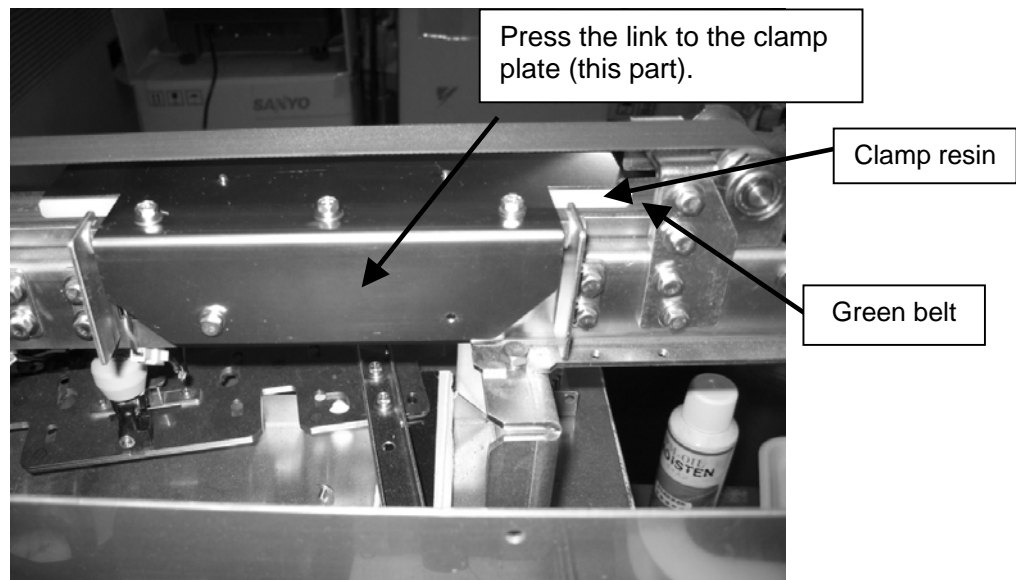
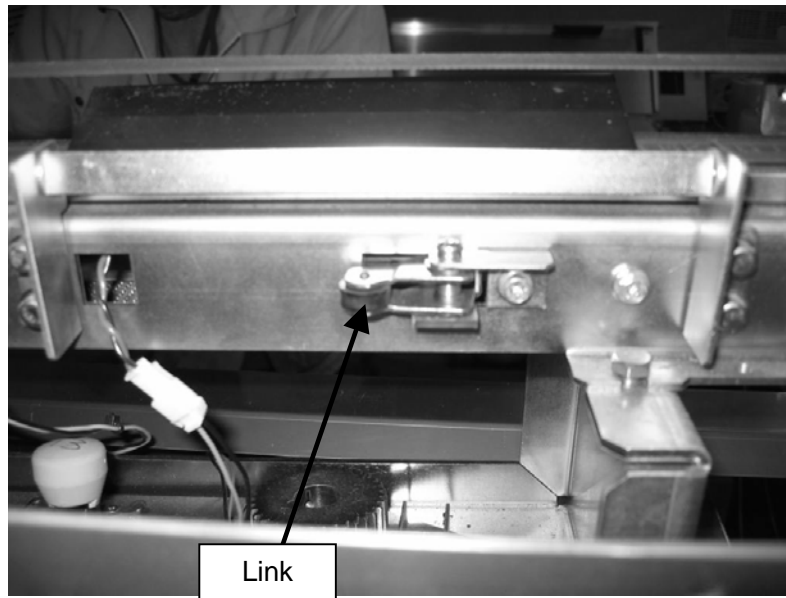

3. Loosen the two screws, move the bracket in the arrow direction, and fix it.

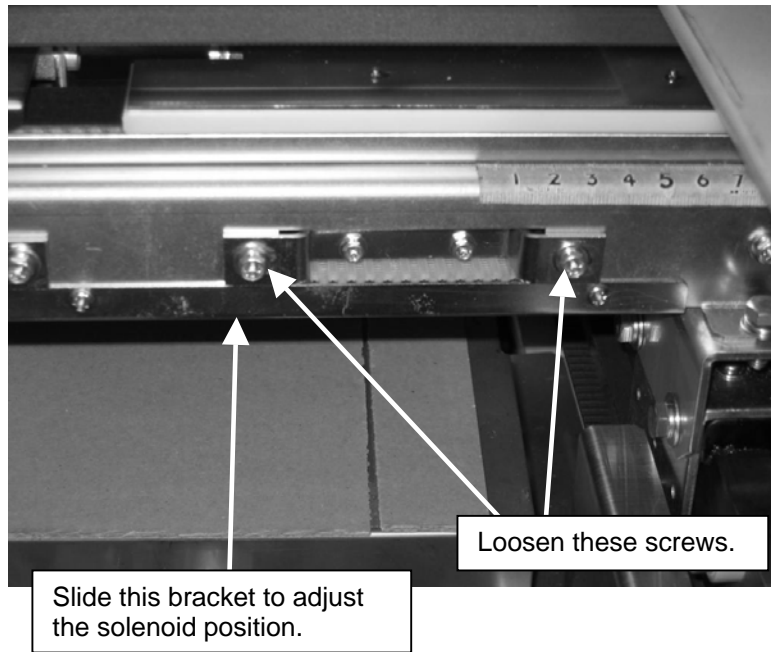

Rear feeder

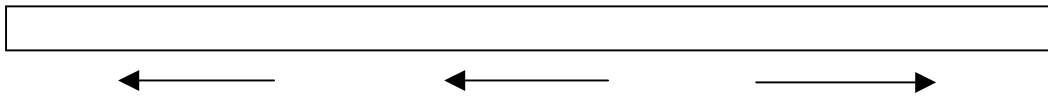

Front feeder

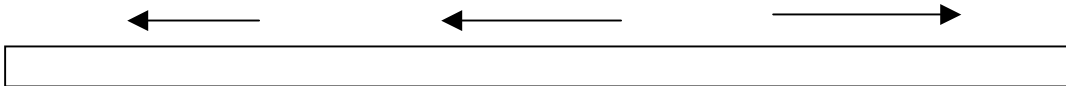

DETAILED ADJUSTMENT EXPALNATION

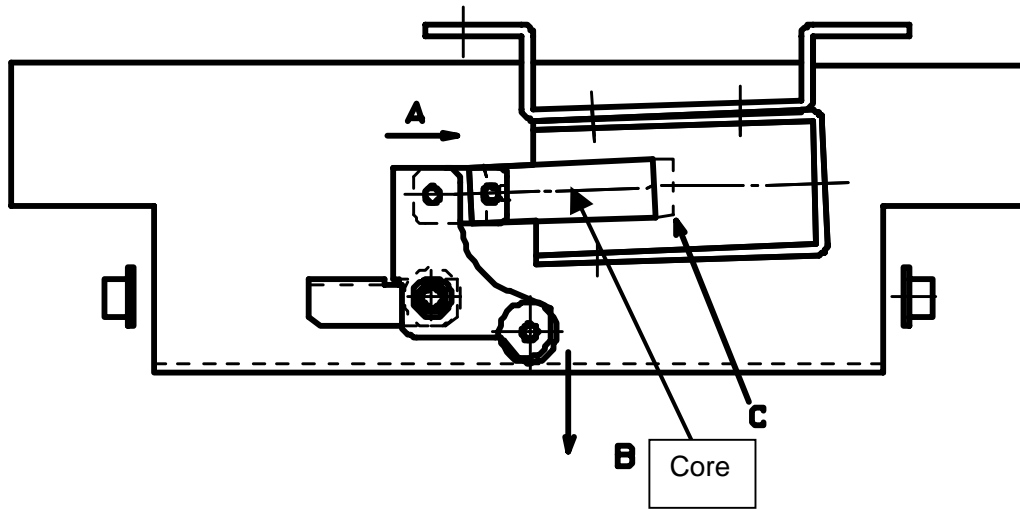

Clamping Operation

- (1) The core is pulled toward “C” point (limit) when the solenoid is energized.
- (2) The link end moves in “A” direction when the core is pulled. Then, the other end moves in “B” direction according to the seesaw principle.
- (3) When the link end is pressed in “B” direction, the clamp resin presses the green belt according to the seesaw principle.

To maximize the clamping power based on above, the solenoid core must be fixed at the position where it can reach “C” point when the clamp resin is pressing the belt.

- 1: However, in consideration of the clamp deflection and the link gap, fix the solenoid after moving it 1 –3 mm in the reverse direction from the position where the core hits “C” point.
- 2: Similarly, when moving the solenoid, the link is pushed by the solenoid and the solenoid will move in the counter direction of “B” and being if the link end is not strongly pressed against the plate in “B” direction. If the solenoid is fixed at this position and energized, the solenoid will not perform of 100% power because the clamp resin comes in contact with the belt before the core reaches “C”. Therefore, when moving the solenoid, it is important to press the link end in “B” direction strongly.

10

**PRINTER PARTS
REPLACEMENT**

CONTENTS

10.1 THERMAL HEAD REPLACEMENT.....	10-2
10.2 PEEL SENSOR REPLACEMENT.....	10-5
10.3 LABEL SENSOR / HEAD-UP SENSOR REPLACEMENT ...	10-7
10.4 PRINT ROLLER REPLACEMENT.....	10-9

10.1 THERMAL HEAD REPLACEMENT

1. Lift the printer head.

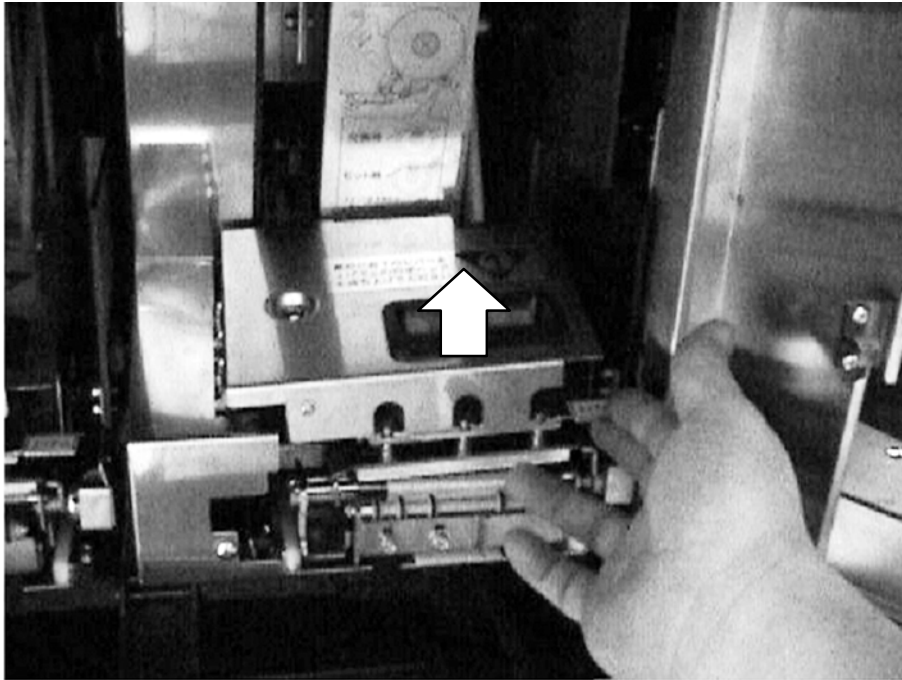

2. Remove the connector in the direction of the arrow.



3. Remove a thermal head with a bracket attached.



4. Remove a thermal head from the bracket. A thermal head comes off from the bracket when two screws of the arrow are removed. Install a new thermal head in the bracket.

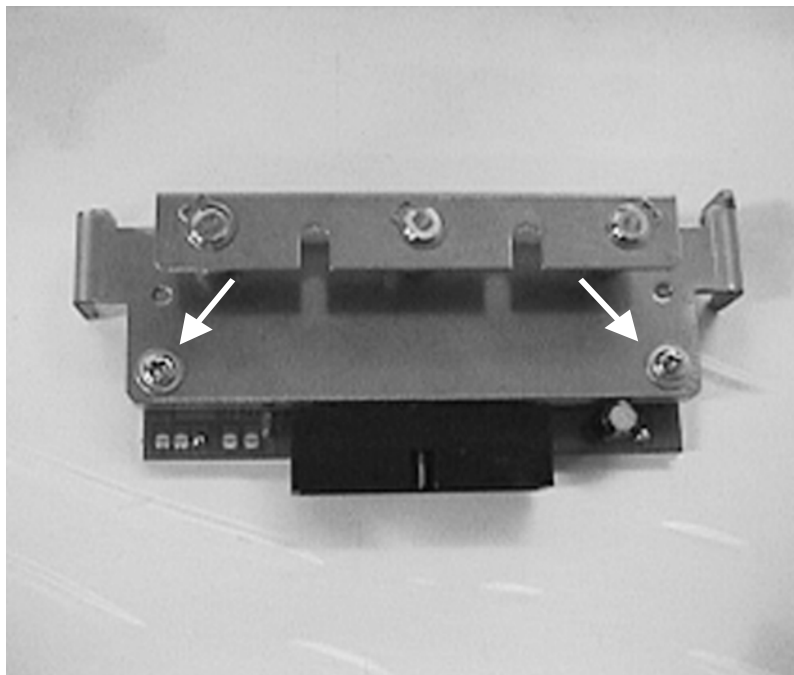

- 5.** Reinstall it, and connect the connectors.



- 6.** Reinstall a thermal head. Start the test mode and set a resistance value. Perform the test print and confirm if the printing is done properly. If it is not done so, readjust the position of the thermal head as it might not be in the right position. Remove the cover of the printer, loosen the screws holding the bracket (refer to above fig.), readjust the position and reinstall it.

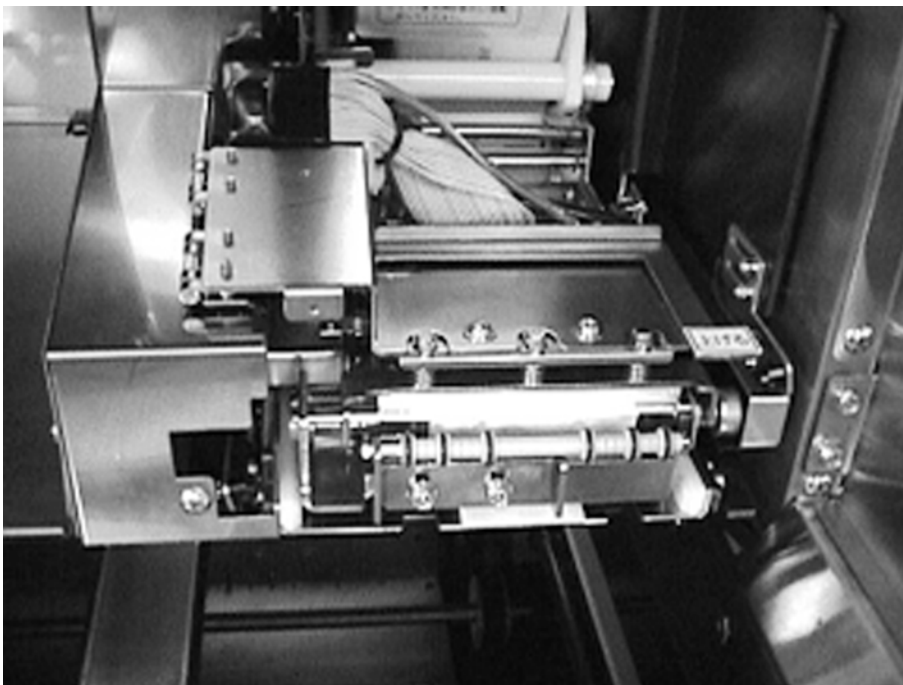

10.2 PEEL SENSOR REPLACEMENT

Emitter side

1. Remove the cover and the two screws.

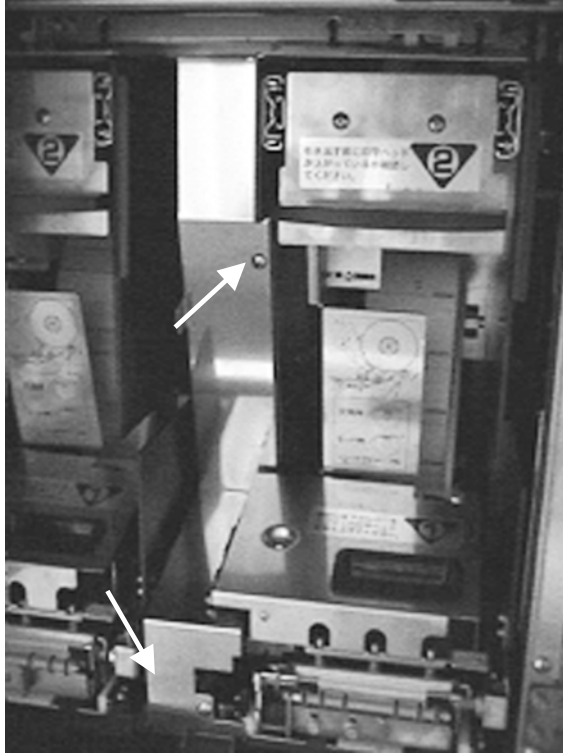

2. Remove the sensor bracket and then the harness from the sensor bracket because these are connected to each other. Remove the sensor from the bracket and replace it with a new one.

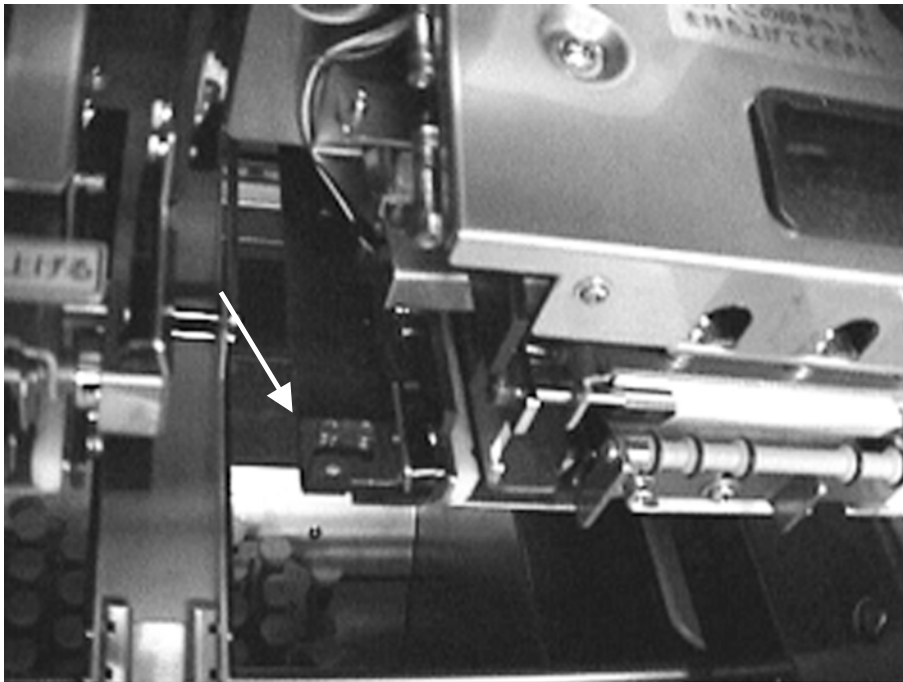

Receiving optical side

1. Remove the harness from the sensor bracket because these are connected to each other. Remove the sensor from the bracket and replace it with a new one.

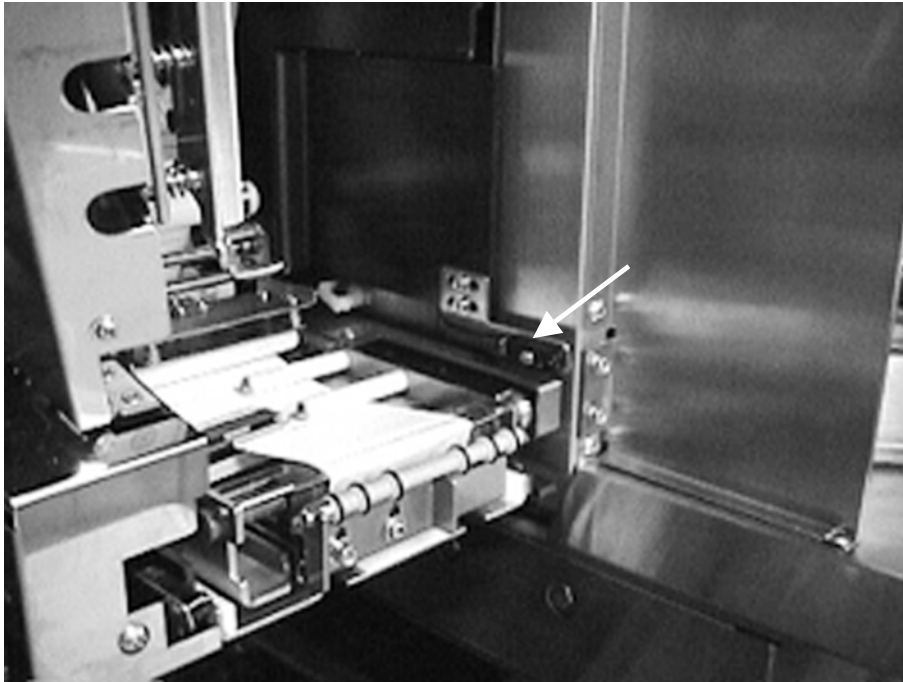

10.3 LABEL SENSOR / HEAD-UP SENSOR REPLACEMENT

The label sensor is made up of the emitter, receiver, head-up sensor and peel sensor.. Replace all of them at the same time.

Note: After the replacement, the sensor level adjustment of the label sensor is needed.

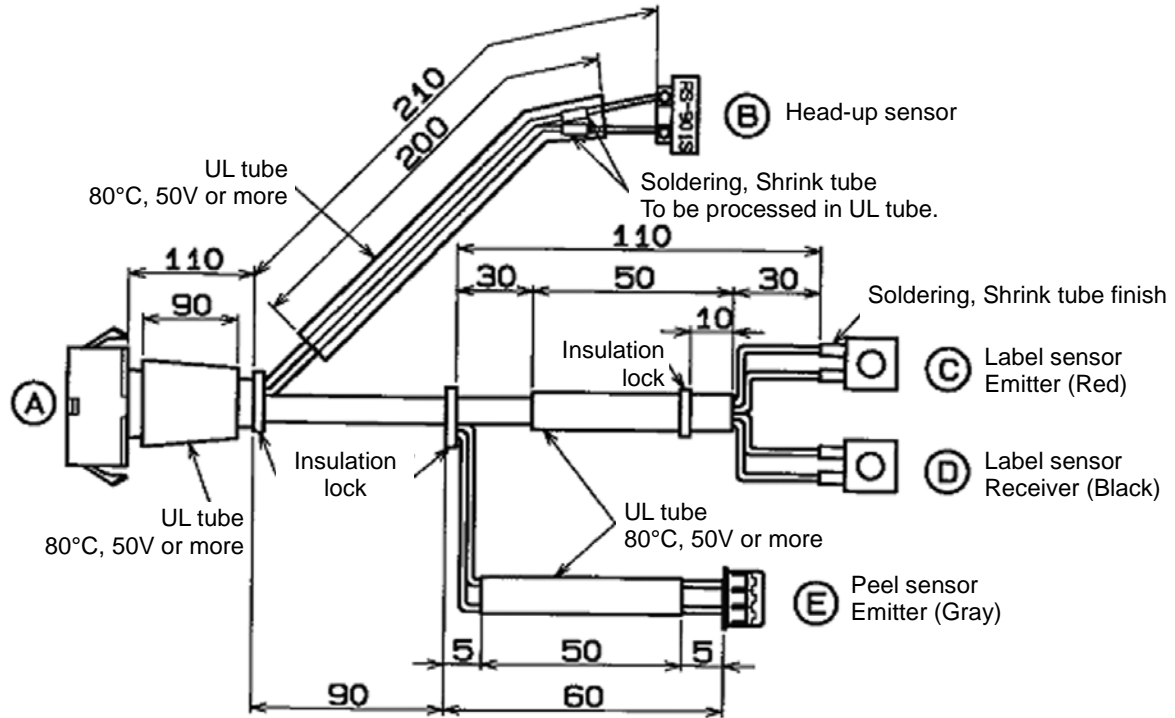

1. Remove the cover and the two screws.

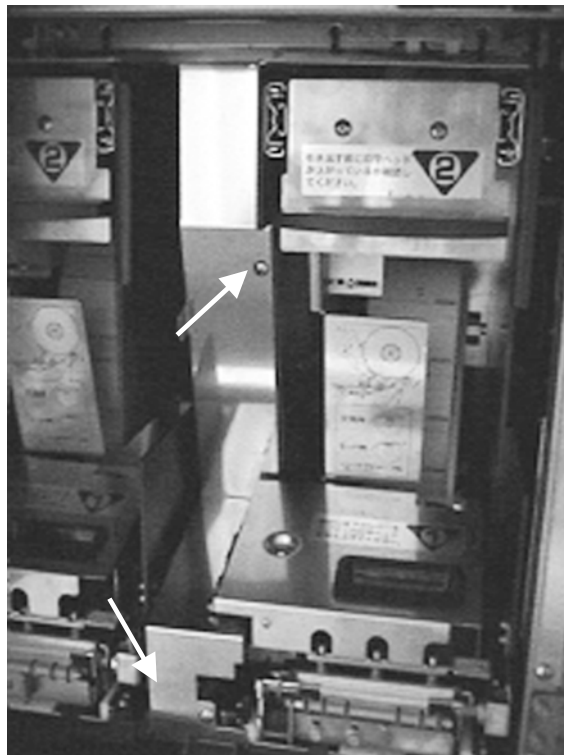

2. Remove the harness and the connectors.

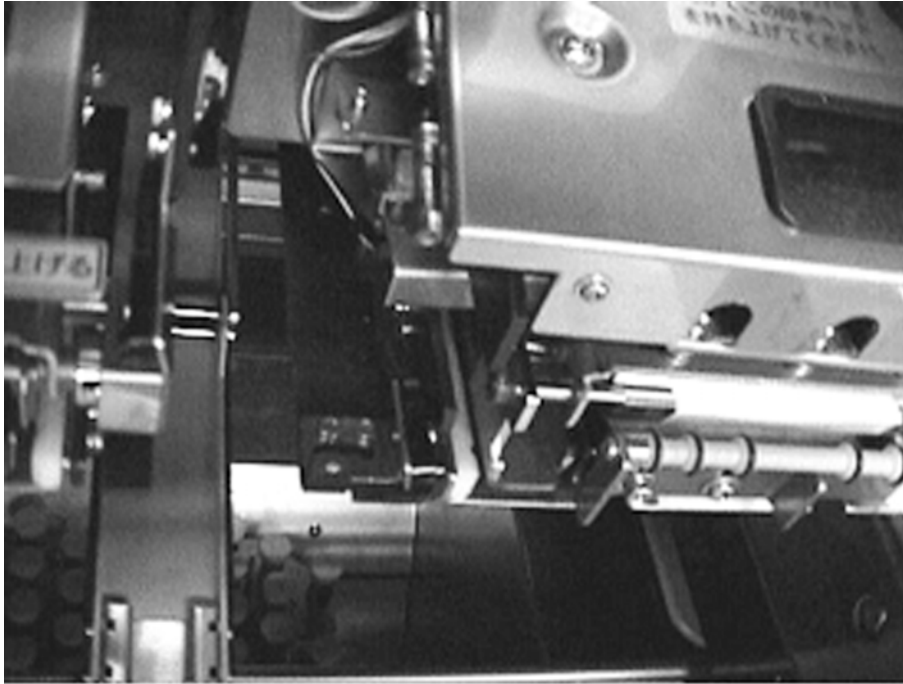

10.4 PRINT ROLLER REPLACEMENT

1. Lift the printer head.

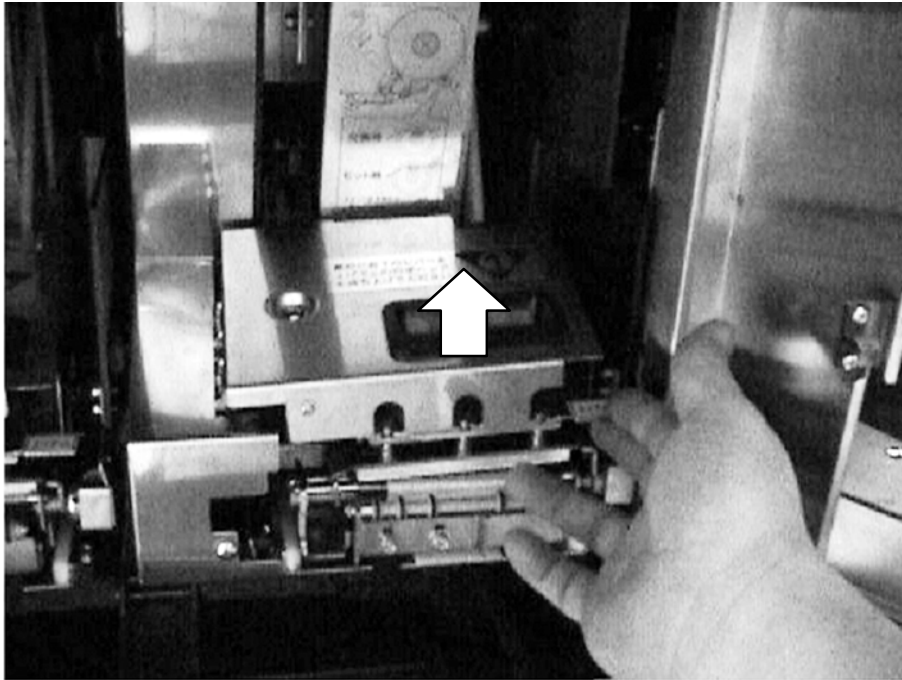

2. Pull out the printer.

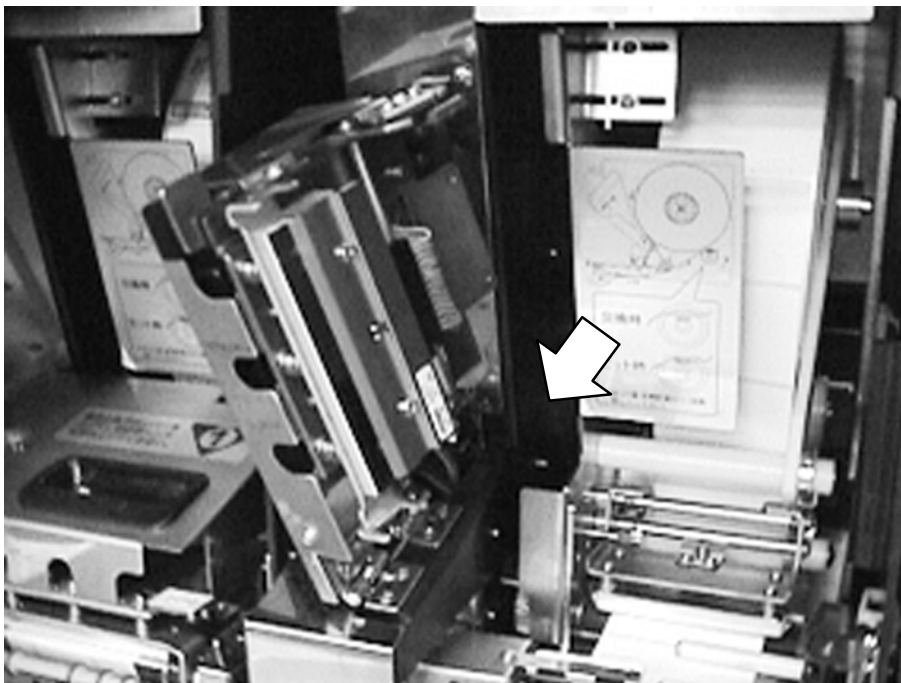

3. Remove the cover and loosen and remove the two screws pointed with the arrow.

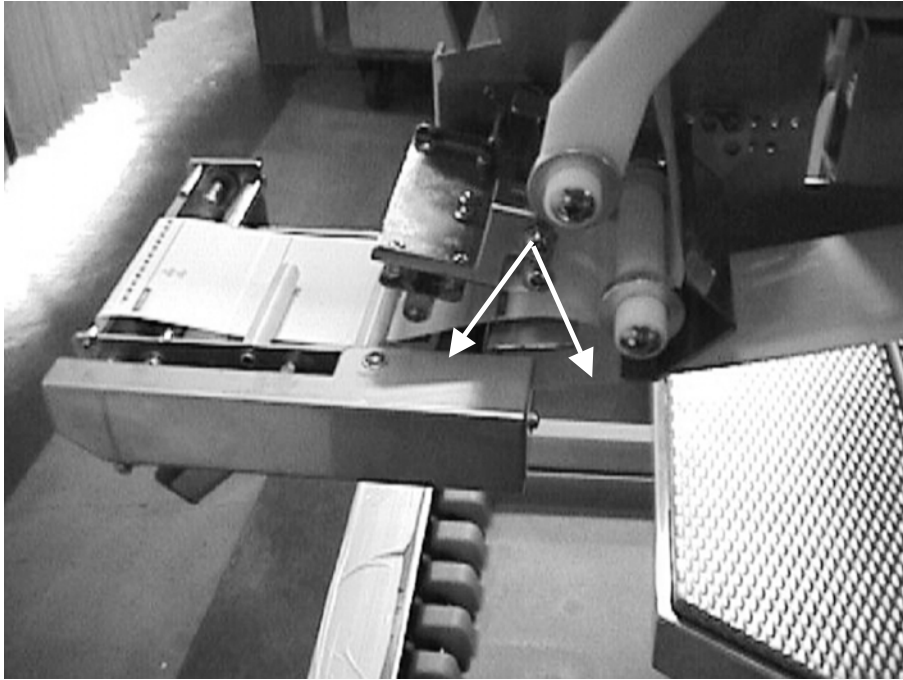

4. Loosen the tension pulley and remove the timing belt.

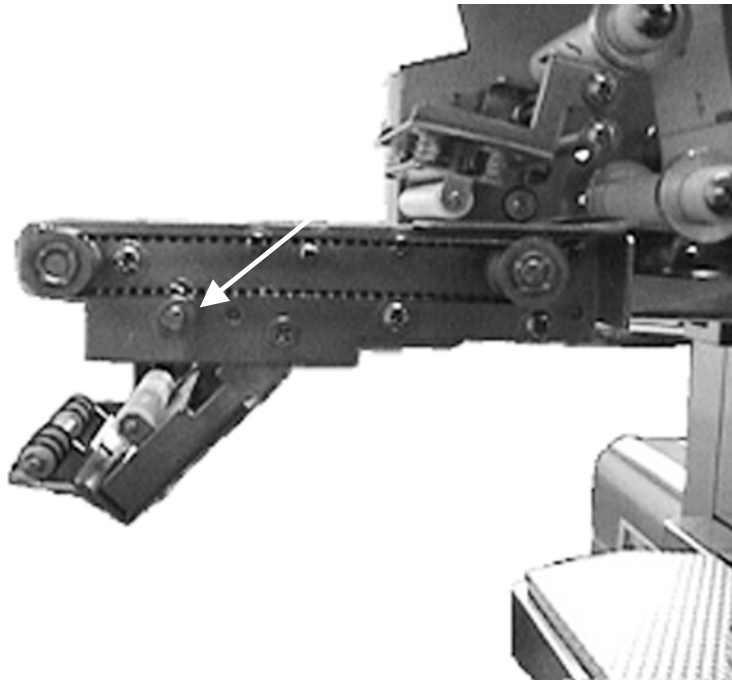

- 5.** Remove the tension pulley and loosen and remove the two screws with the arrow.

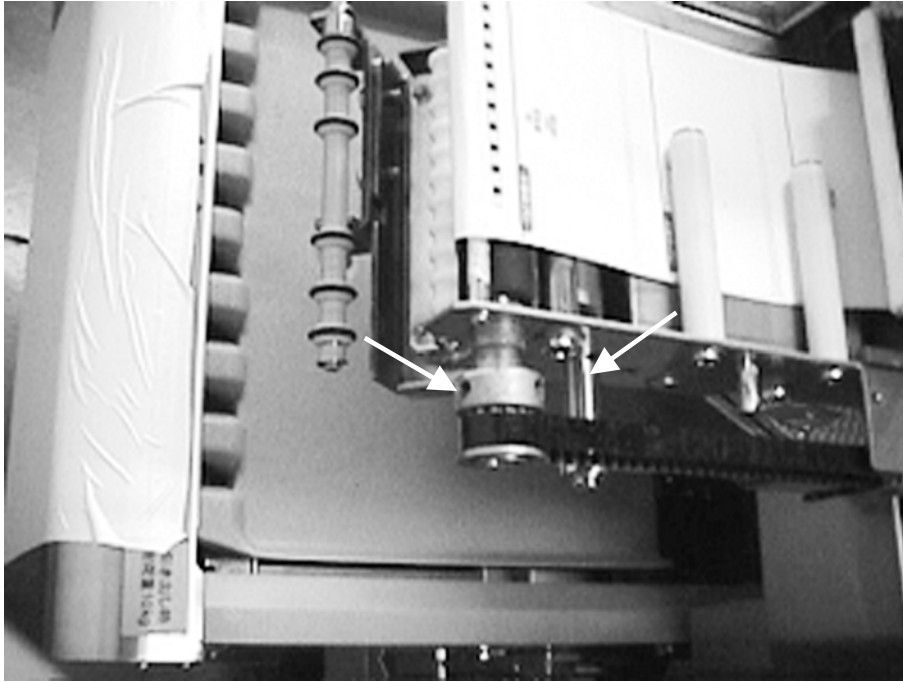

- 6.** Remove the frame and remove the print roller. Loosen the four screws with the arrow.

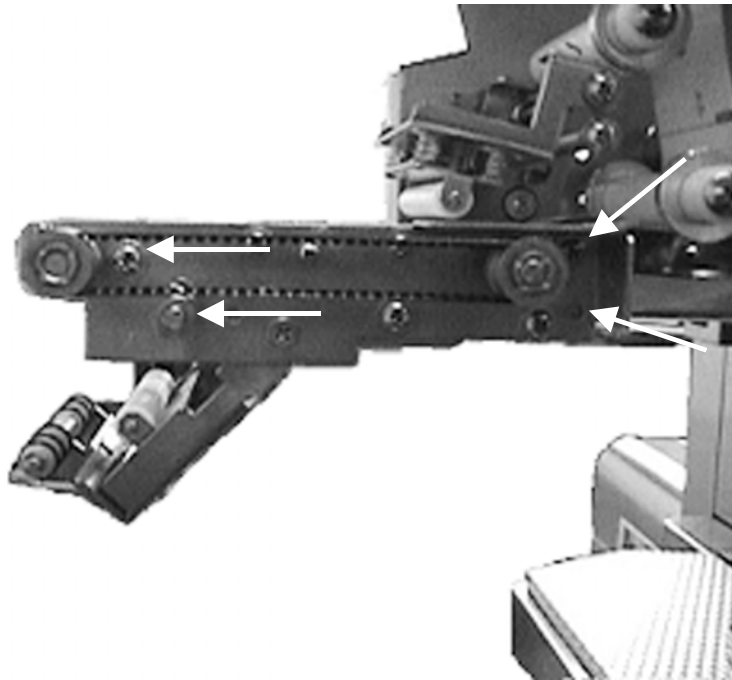

11

ELECTRICAL SIGNALS

CONTENTS

11.1 MAIN PC BOARD (P-910H-2)	11-2
11.2 WRAPPER MAIN BOARD (P-857*)	11-6
11.3 WRAPPER I/O BOARD (P-858A-*) A TYPE	11-11
11.4 WRAPPER I/O BOARD (P-858A-*) B TYPE	11-15
11.5 WRAPPER I/O BOARD (P-858A-*) C TYPE	11-19
11.6 EMERGENCY STOP BUTTON (IDEC'2B[HW1B-V402R]:064-9296-**)	11-22
11.7 SAFETY COVER SWITCH	11-23
11.8 SAFETY SWITCH ASSY. (091-0690-**)	11-24
11.9 DISCHARGE PUSHER	11-25
11.10 THERMAL PC BOARD (P-909C-3)	11-26
11.11 APPLICATOR CONTROL PC BOARD (P-916B)	11-29
11.12 CONTROL CONSOLE PC BOARD (P-917-1)	11-34
11.13 CONNECTOR RELAY PC BOARD (P-918A-1) ...	11-36
11.14 DISPLAY JUNCTION PC BOARD (P-919B-3)	11-38
11.15 THERMAL HEAD RELAY PC BOARD (P-925*) ..	11-39
11.16 SCALE PC BOARD (P-930A-1)	11-40
11.17 LAN PC BOARD (P-967-1)	11-42
11.18 SW POWER SUPPLY (DL912W) U220	11-43
11.19 SW POWER SUPPLY (DL912W-1) U51	11-45

11.1 MAIN PC BOARD (P-910H-2)

This board controls the entire machine. It is located in the right side cover of the main body.

- **Main storage data**
 - Master data such as PLU master, etc.
- **Work after PC board replacement**
 - When there is backup data, load it directly into "CF".
 - Turn on the battery switch when the PC boards is replaced.
 - The lithium battery is installed on the PC board. When discarding the battery, discard it to the specified place.
- **I/O signal**

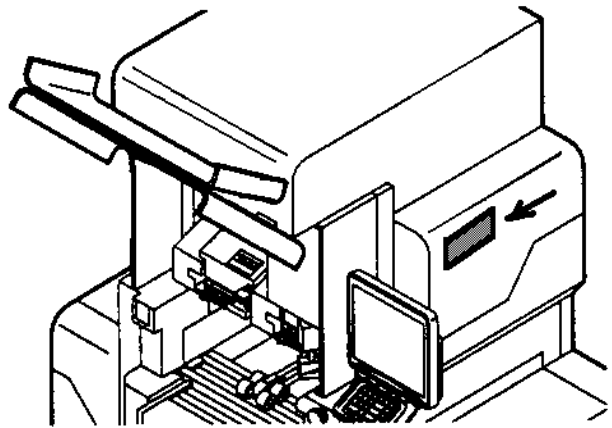

XJ1 (Harness C2 communication: 069-4846-**)

No.	Signal name	Color	Other side	No.	No.	Signal name	Color	Other side	No.
1	RS-232C	Brown	P-918 (XJ5)	1	21	Not used	-	P-918 (XJ5)	-
2		Red		2	22		-		
3		Orange		3	23		-		
4		Yellow		4	24		-		
5		Green		5	25		-		
6		Blue		6	26		-		
7		Purple		7	27		-		
8		Gray		8	28		-		
9	I2NET (ELAN)	White		9	29	-			
10		Black		10	30	-			
11		Brown		11	31	-			
12	I2NET (ILAN)	Red		12	32	DC+24[V]	Red		19
13		Orange		13	33		Orange		20
14		Yellow		14	34	GND	Yellow		21
15		Green		15	35		Green		22
16	Blue	16		36	Blue		23		
17	RS-485	Purple		17	37		Purple		24
18		Gray		18	38		-		-
19	Not used	-		-	39	Not used	-		-
20		-		-	40		-		-

XJ2 (Harness C3 power supply: 069-6685-**)

No.	Signal name	Color	Other side	No.	Other side	No.
1	+5[V]	Red	Switching power supply (CN7)	1	P-919 (XJ7)	-
3	+12[V]	Yellow		2		1
-	-	-		3		-
2	5[V]GND	Black		4		-
4	12[V]GND	Black		5		2

XJ3 (Jiont PC boards)

No.	Signal name	Direction	Other side
A1 - A60 B1 - B60	Signal between P-909 and P-910		P-909 (XJ100)

XJ5 (Harness S2 RS-232C:069-6688-)**

No.	Signal name	Color	Direction	Other side	No.
1	RS232C TxD	Brown	→	To P-917 (XJ13) via P-919 (XJ4)	3
2	RS232C RTS	Red	→		4
3	RS232C RxD	Orange	←		1
4	RS232C CTS	Yellow	←		2
5	RS232C +5[V]	Green	→		5
6	RS232C SG	Blue	-		6
7	RS232C FG	Purple	-		7

XJ6 (Harness S2 power supply relay: 063-8454-)**

No.	Signal name	Color	Direction	Other side	No.
1	DC+24[V]	Brown	←	P-909 (XJ9)	1
2	GND	Red	-		2

XJ7 (Harness C2 peripheral INT 4847 1:069--)**

No.	Signal name	Color	Other side	No.	No.	Signal name	Color	Other side	No.	
1	-	-	P-918 (XJ5)	-	16	-	-	P-918 (XJ5)	-	
2	-	-		-	17	-	-		-	-
3	-	-		-	18	-	-		-	-
4	-	-		-	19	Wrapper state inquiry request signal	White			6
5	-	-		-	20	General-purpose input 1	Black			5
6	-	-		-	21	General-purpose input 2	Brown			4
7	-	-		-	22	Applicator state inquiry request signal	Red			3
8	-	-		-	23	Not used	Orange			2
9	-	-		-	24	Applicator label issue timing signal	Yellow			1
10	-	-		-	25	DC+5[V]	Green			7
11	-	-		-	26	DC+5[V]	Blue			8
12	-	-		-	27	-	-			-
13	-	-		-	28	GND	Gray			9
14	-	-		-	29	GND	White			10
15	-	-		-	30	-	-			-

XJ8 (Harness C2 scale: 090-0940-)**

No.	Signal name	Direction	Color	Other side	No.
1	IN+	←	Brown	To X291 via the X292 connector To Scale unit	1
2	-	-	-		2
3	IN-	-	Orange		3
4	D	← →	Yellow		4
5	D	← →	Green		5
6	VH+	→	Blue		6
7	GND	-	Purple		7
8	VH-	-	Gray		8
9	FG	-	Black		9

XJ9 (Harness C4LCD junction: 098-3157-)**

No.	Signal name	Color	Other side	No.	No.	Signal name	Color	Other side	No.
1	LCD control signal	Brown	To P-917 (XJ13) via P-919 (XJ3)	1	8	LCD control signal	Gray	To P-917 (XJ13) via P-919 (XJ3)	8
2		Red		2	9	DC+5[V]	White		9
3		Orange		3	10	GND	Black		10
4		Yellow		4	11	-	Brown		11
5		Green		5	12	-	Red		12
6		Blue		6	13	-	Orange		13
7		Purple		7	14	-	Yellow		14

XJ10 (One harness for XJ9 and XJ10)

No.	Signal name	Color	Other side	No.	No.	Signal name	Color	Other side	No.
1	LCD control signal	Brown	P-919 (XJ3) Relay it. P-917 (XJ13)	1	9	LCD control signal	White	P-919 (XJ3) Relay it. P-917 (XJ13)	9
2	-	Red		2	10		Black		10
3	LCD control signal	Orange		3	11		Brown		11
4	LCD control signal	Yellow		4	12		Red		12
5	GND	Green		5	13		Orange		13
6	LCD control signal	Blue		6	14		Yellow		14
7	GND	Purple		7	15		Green		15
8	LCD control signal	Gray		8					

XJ11 (Harness C2 inverter junction: 069-6689-)**

No.	Signal name	Color	Direction	Other side	No.
1	DC+12[V]	Brown	→	To P-917 (XJ13) via P-919 (XJ6).	1
2	GND	Red	-		2
3	Buzzer ON/OFF	Orange	→		3
4	Not used	-	-		-
5		-	-		-

XJ18 (Harness S2 Ethernet: 096-7500-)**

No.	Signal name	Color	Direction	Other side	No.	No.	Signal name	Color	Direction	Other side	No.
1		Yellow	→	P-967-1 (XJ1)	1	5		Black	→	P-967-1 (XJ1)	5
2		Black	→		2	6		Black	→		6
3		Black	←		3	7		Black	←		7
4		Black	←		4	8		Black	←		8

11.2 WRAPPER MAIN BOARD (P-857*)

This board controls output from the main board concerning the wrapping machine. It is located in the lower cover of the left side of the main body.



- DIP switch 1: OFF from 1 through 4.
- DIP switch 2: ON from 1 through 3 and 6, OFF at 4, 5, 7, and 8 (default)
- Work after board replacement
 - After board replacement, use the main ROM with the same version, and confirm the mask ROM number.
- I/O Signals

J1 (Harness C2 power supply: 108-0224-**)

No.	Signal Name	Color	Other Side	No.
1	24V power supply input	Brown	Power supply switching SLS150PW (CN1:6P)	1
2		Red		2
3		Orange		4
4		Yellow		5

J2 (Harness S2 24V:108-0233-**)

No.	Signal Name	Color	Other Side	No.
1	+24[V]	White	P-858 A (J4)	1
2	+24[V]	White		2
3	24[V] GND	Black		3
4	24[V] GND	Black		4

J3 (Harness S2 24V:108-0232-**)

No.	Signal Name	Color	Other Side	No.
1	+24[V]	White	P-858 B (J4)	1
2	+24[V]	White		2
3	24[V] GND	Black		3
4	24[V] GND	Black		4

J4 (Buzzer AS:040-6902-**)

No.	Signal Name	Color	Other Side
Red 1	+24[V]	White	FDK DC24V
Black 2	+24[V]	White	EB4015B-28C150-24V

J5 (Harness C5 outside signal: 103-3934-) Refer to * P-916 XJ18.**

No.	Signal Name	Color	Other Side	No.
1	-	-	Applicator fixed part To P-916 XJ18 Labeling timing signal	-
2	GND	Black		15
3	Out	Green		16
4	-	-		-
5	-	-		-

J6 (J7 and union goods)

No.	Signal Name	Color	Other Side	No.
1	24V	Brown	Discharge speed controller DC brushless motor To each terminal	D1
2	24G	Red		D10
3	CW	Orange		D3
4	CCW	Yellow		D4
5	EXT·VR	Green		D2
6	-	-		-
7	-	-		-

J7 (Harness C 3947 19:103--)**

No.	Signal Name	Color	Other Side	No.	No.	Signal Name	Color	Other Side	No.
1	-	-	-	-	17	24V	White	Film detection sensor (rear right) BBR	3
2	Vcc	White	Infeed safety sensor B21	1	19	S	Blue		1
4	GND	Black		2	20	GND	Black		2
5	-	-	-	-	21	24V	White	Film detection sensor (front left) BFL	3
3	-	Brown	P-858 AJ20 3-phase circuit check	1	23	S	Purple		1
7	-	Orange		2	24	GND	Black	2	
11	-	Yellow		3	25	24V	White	Film detection sensor (rear left) BBL	3
12	GND	Black	4	27	S	Gray	1		
9	-	-	-	-	28	GND	Black	2	
10	-	-	-	-	26	-	-	-	
6	Vcc	White	Infeed safety sensor B22	1	30	-	-	-	
8	GND	Black		2	29	24V	White	Origin of side squeezing B7	+
14	-	-	-	-	31	S	Brown		Out
13	24V	White	Film detection sensor (front right) BFR	3	32	GND	Black	-	
15	S	Green		1	33	-	-	-	
16	GND	Black		2	35	ALM	Orange	DC Brushless alarm origin D12	10
18	-	-	-	-	34	Vcc	White	Foreign article detection sensor B13	1
22	-	-	-	-	36	GND	Black		2

J9 (Harness C6 sensor: 103-3850-)**

No.	Signal Name	Color	Other Side	No.	No.	Signal Name	Color	Other Side	No.
1	24V	White	Feeder count CT1	Plus	13	-	-	Safety sensor (Infeed unit 2) B22	-
2	-	-		-	14	Vcc	White		1
3	S	Brown		OUT	15	S	Green		2
4	GND	Black		Minus	16	GND	Black		3
5	24V	White	Left/Right squeezing count CT2	Plus	17	-	-	Foreign article detection B13	-
6	-	-		-	18	Vcc	White		1
7	S	Orange		OUT	19	S	Blue		2
8	GND	Black		Minus	20	GND	Black		3
9	-	-	Safety sensor (Infeed unit 1) B21	-	21-28 pins are not used.				
10	Vcc	White		1					
11	S	Yellow		2					
12	GND	Black		3					

J14, J15 (Harness C3 communication: 103-3955-)**

No.	Signal Name	Color	Other Side	No.
J14 1	OUT-	Red	Relay the X270(6P) connector. To P-918 XJ2, 8, 9, and 11	2
2-9 is not used.		-		
J15 1	D#	Orange		4
2	D	Yellow		3
3	SG	Green		5
4	FG	Blue		6
5-8 is not used.		-		

J16 (Harness S2 I/ONET:040-6839-)**

No.	Signal Name	Color	Other Side	No.
1	Control I/O +	Brown	To P-858 A J1 IONET	1
2	Control I/O -	Red		2
3	I/O Control +	Orange		3
4	I/O Control -	Yellow		4
5	SG	Green		5
6	FG	Blue		6

J17 (Assembled with J7, same part number as J16 in single unit)

No.	Signal Name	Color	Other Side	No.
1	Control I/O +	Brown	To P-858 B J1 IONET	1
2	Control I/O -	Red		2
3	I/O Control +	Orange		3
4	I/O Control -	Yellow		4
5	SG	Green		5
6	FG	Blue		6

J18 (Harness S2 earth: 040-6856-)**

No.	Signal Name	Color	Other Side	No.
1	FG	-	Frame ground	

J20 (Harness C3 servo communication: 103-3945-)**

No.	Signal Name	Color	Other Side	No.	No.	Signal Name	Color	Other Side	No.
1	STB	Brown	Servo amplifier X5	24	12		-	Servo amplifier X5	-
2	CCWL	Red		19	13	VH	White		1
3	CWL	Orange		20	14	GND	Black		17
4	-	-		4	15	EMG-STP	Yellow		12
5	-	Green		5	16	-	-		13
6	-	-		6	17	SD	Blue	Servo amplifier X7	3
7	BUSY	Purple		32	19				6
8	-	-		8	18	SD#	White		-
9	-	-		-	20				2
10	-	-		-	21				5
11	ALM	Brown		15	22	GND	Orange Green		

J21 (Harness C3 sensor: 108-0241-)**

No.	Signal Name	Color	Other Side	No.
1	-	-	-	-
2	-	-	-	-
3	-	-	-	-
4	-	-	-	-
5	-	-	-	-
6	24V	White	To the lift lower limit sensor via LSN connector	1
7	S	Orange		2
8	GND	Black		3
9	-	-	-	-
10	-	-	-	-
11	S	Yellow	To electromagnetic contactor via MGNT connector. (13,14,X9)	1
12	GND	Black		2

J22 (Harness C2ST driver: 076-1891-)**

No.	Signal Name	Color	Other Side	No.
1	-	-	Oriental 24V Sstepping motor driver To CN2 [059-8058-**:G0070-044]	-
2	-	-		-
3	-	-		-
4	-	-		-
5	Vcc	Brown		1
6	GND	Red		2
7	CW	Orange		3
8	CCW	Yellow		4
9	PD	Green		5
10	F/H	Blue		6

J24 (Harness C4 Infeed: 076-1892-)**

No.	Signal Name	Color	Other Side	No.
1	DC+24[V]	White	To the Infeed original point sensor via S16 connector	3
2	-	-		-
3	S	Brown		1
4	GND	Black		2
5	-	-		-
6	-	-		-
7	-	-		-
8	-	-		-

[DIP switch 2]

No.	Contents	ON	OFF
1	Availability of automatic labeling	Automatic labeling	Manual labeling
2	Availability of lift change	Yes	No
3	Availability of film change	Yes	No
4	Lower right film loading	Yes	No
5	Reserve	-	-
6	Availability of manual insertion error	Yes	No
7	Selection of film width (3 for right)	Yes	No
8	Not used film existence sensor	Execution	Invalidity

Note: Set JP14 and JP15 to 'ROM256'.

24V Infeed Stepping Motor Driver: 059-8058-: G0070-044****CN1 (Harness C2 stepping: 103-3835-**))**

No.	Signal Name	Color	Other Side	No.
1	-	White	To SMT24 junction connector	1
2	-	Black		2

Refer to P-858B J24 for SMT24 junction connector and thereafter.

CN2 (P-857 J22 harness C2ST driver: Refer to 076-1891-.)****CN3 (Harness C4 Infeed: 076-1892-**) Same part number as P-857 J24.**

No.	Signal Name	Color	Other Side	No.
1	-	Blue	To Infeed stepping motor 059-8057-**: Oriental DC24V A5800-9415K	1
2	-	Red		2
3	-	Orange		3
4	-	Green		4
5	-	Black		5
6	-	-		-

11.3 WRAPPER I/O BOARD (P-858A-*) A TYPE

This board controls input and output signals from the wrapper main board. It controls each squeezing plate, feeder motor and brake, feeder move sensor, discharge pusher sensor, commodity detection sensor on the lift, etc. movement sensor, etc.
It is located in front of the wrapper main board (P-857*) at the left side of the main body.



Note 1: Settings of the DIP switch on the board are different for each P-857* installation location(A/B/C).

For "A" type, set the DIP switch of the board as follows.

Dip switch
1: ON
2: OFF
3: OFF
4: OFF

Note 2: A number is described on the version seal for P-858*.

The number 2 can only be used for P-858B and P-858C though the number 1 can be used for all positions.

● I/O Signals

Refer to J1 (P-857 J16: harness IONET:040-6839-**).

J3 (Harness S2 earth: 040-6856-**))

No.	Signal Name	Direction	Other Side
1	FG	-	Frame ground

J4 (P-857 J2: Refer to harness S2 24V.)

J5 (Harness S2 24V:076-1888-**))

No.	Signal Name	Color	Other Side	No.
1	+24[V]	White	P-858 C (J4)	1
2	+24[V]	White		2
3	24[V] GND	Black		3
4	24[V] GND	Black		4

J8 (Harness C5 DC drive: 108-0467-**))

No.	Signal Name	Color	Other Side	No.
1	24V	White	Left/Right squeezing motor brake D0A	1
2	OUT	Brown		2
3	24V	White	Front/Rear squeezing motor brake D1A	1
4	OUT	Red		2
5	-	-	-	-
6	24V	White	Feeder move motor brake D2A	1
7	OUT	Orange		2
8	24V	White	Feeder motor brake D3A	1
9	OUT	Yellow		2

J9 (Harness C5 DC drive L: 103-3949-) Refer to P858C J10 and J11.**

No.	Signal Name	Color	Other Side	No.
1	-	-	Not used	-
2	-	-		-
3	-	-		-
4	-	-		-
5	-	-		-
6		White	Front left feeder. (each solenoid and fan)	1
7		Orange	FCFL connector (16P)	2
8		White	Rear left feeder (each solenoid and fan)	1
9		Yellow	FCBL connector (16P)	2

* Class goods composition of FCFL/FCBL connector of above-mentioned connector (P-858A J9) and P-858C J10 and J11.

FCFL connector (Harness C5 feeder FL front: 103-3952-)**

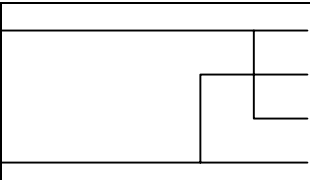
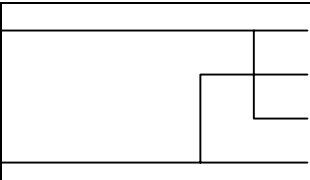
No.	Signal Name	Color	Other Side	No.
1		White	The right junction connector in front of the clamp solenoid. CFR	1
		Brown		2
2		White	The left junction connector in front of the clamp solenoid. CFL	1
		Brown		2
3		White	The left junction connector in front of the separation solenoid.	1
4		Orange		2
5		White	The left junction connector in front of the film fan. FFL	1
6		Yellow		2

7-16 are not used.

FCFL connector (Harness C5 feeder FL front: 103-3952-)**

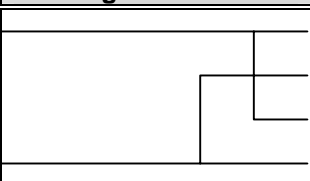
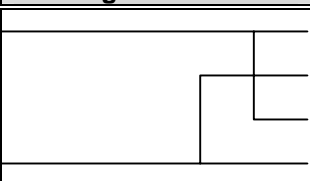
No.	Signal Name	Color	Other Side	No.
1		White	Junction connector for rear right clamp solenoid CBR	1
		Brown		2
2		White	Junction connector for rear left clamp solenoid CBL	1
		Brown		2
3		White	Junction connector for rear left separation solenoid	1
4		Orange		2
5		White	Junction connector for front left film fan. FBL	1
6		Yellow		2
7		Green	Junction connector for rear left film detection sensor	1
8		Black		2
9		White		3

10-16 are not used.

J10 (Harness C2 magnet coil: 103-3822-)**

No.	Signal Name	Color	Direction	Other Side	No.
1	VH	White	←	Junction connector (XL2P) Relay, and to the safety switch	1
2	-				
3	VH	Black	←		2
4	-		-		

J12 (Harness C8 board power supply: 103-3942-)**

No.	Connector name	Color	Other Side	No.
1	P-858A J12	Red	f22	-
2		White	f21	-
3		Black	f23	-
1	P-858C J12	Red	f22	-
2		White	f21	-
3		Black	f23	-

* f = Fuse

J13, J14, J15, J16 (Harness C6 squeezing: 108-0223-)**

No.	Signal Name	Color	Other Side	No.	
J13 1	P-858A	Brown	Left/Right squeezing motor (M1)	1	
2		Red		2	
J14 1	P-858A	-		-	
2		Orange		3	
J15 1	P-858A	Brown		Front/Rear squeezing motor (M2)	1
2		Red			2
J16 1	P-858A	-	-		
2		Orange	3		

J17, J18 (Harness C3 Feeder move: 108-0130-)**

No.	Signal Name	Color	Other Side	No.
J17 1	P-858A	Brown	Feeder move motor (M3)	1
2		Red		2
J18 1	P-858A	-		-
2		Orange		3

J19 (Harness C4 thermal relay: 103-3818-)**

No.	Signal Name	Color	Other Side	No.
1	P-858A	Black	Thermal relay (TK-0NH1.4-2.2A) 017-5673-**)	L3
2		White		L2
3		Red		L1
-		-		-

Refer to J20 (P-857 J7 harness C 3947-**) 19:103-).

J21 (Harness C7 sensor: 108-0133-)**

No.	Signal Name	Color	Other Side	No.	No.	Signal Name	Color	Other Side	No.
1	V24	White	Front/Rear squeezing original point B0A	+	13	V24	White	Pusher front limit B3A	+
2	-	-		-	14	-	-		-
3	S	Brown		OUT	15	S	Green		OUT
4	GND	Black		-	16	GND	Black		-
5	V24	White	Front/Rear squeezing front limit B1A	+	17	V24	White	Full sensor B311	1
6	-	-		-	18	-	-		-
7	S	Orange		OUT	19	S	Blue		2
8	GND	Black		-	20	GND	Black		3
9	V24	White	Pusher Original point B2A	+	21	V24	White	On-lift commodity detection B5A	3
10	-	-		-	22	-	-		-
11	S	Yellow		OUT	23	S	Purple		1
12	GND	Black		-	24	GND	Black		2

* Photo-interrupter (transparent): 012-8583 -**(OMRON: EE-SX671)

J22 (Harness C4 sensor: 108-0126-)**

No.	Signal Name	Color	Other Side	No.
1-12, 14, 18, 22, 25, and 26 are Not used.				
13		White	Feeder rear limit B 9A	+
15		Green		OUT
16		Black		-
17		White	Feeder middle point B10A	+
19		Blue		OUT
20		Black		-
21		White	Feeder front limit B11A	+
23		Purple		OUT
24		Black		-

J23 (P-857 J16: Harness IONET:040-6839-)**

No.	Signal Name	Color	Other Side	No.
1	Control → I/O +	Brown	To P-858 C J1 IONET	1
2	Control → I/O -	Red		2
3	I/O → control +	Orange		3
4	I/O → control -	Yellow		4
5	SG	Green		5
6	FG	Blue		6

11.4 WRAPPER I/O BOARD (P-858A-*) B TYPE

This board controls input and output signals from the wrapper main board. It controls IONET communication, lift head position sensor, discharge motor drive, lift change motor drive, and others related to the right film drive.

It is located in the right side cover (above the insert film) of the main body.

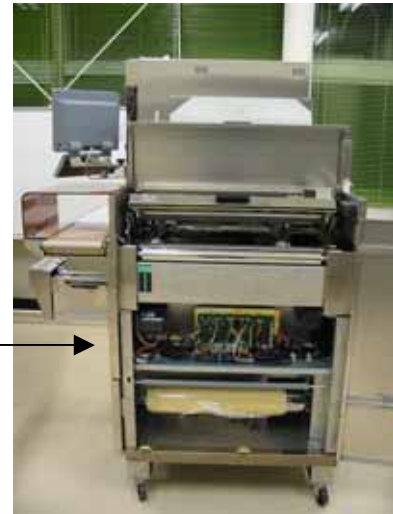

Note 1: Settings of the DIP switch on the board are different for each P-858* installation location (A/B/C).

For "B" type, set the DIP switch on the board as follows.

Dip Switch
1: OFF
2: ON
3: OFF
4: OFF

Note 2: A number is described on the version seal for P-858*.

The number 2 can only be used for P-858B and P-858C though the number 1 can be used for all positions.

● I/O Signals

J1 (Harness S2 I/ONET: 040-6839-**)

No.	Signal Name	Color	Other Side	No.
1	Control → I/O +	Brown	To P-857 J17 IONET	1
2	Control → I/O -	Red		2
3	I/O → Control +	Orange		3
4	I/O → Control -	Yellow		4
5	SG	Green		5
6	FG	Blue		6

J3 (Harness S2 earth: 040-6856-**))

No.	Signal Name	Direction	Other Side
1	FG	-	Frame ground

J4 (Refer to P-857 J3 harness S2 24V: 108-0232-**.)

* Harness of 103-3846-** includes J6, J7, J8, and J21.

J6 (Harness C12R: 103-3846-)**

No.	Signal Name	Color	Other Side	No.
1	OUT1	Red	Film pinch motor R DC0	1
2	-	-		-
3	OUT2	Brown		2

J7 (Harness C12R: 103-3846-)**

No.	Signal Name	Color	Other Side	No.
1	OUT1	Red	Film up and down motor R DC1	1
2	-	-		-
3	OUT2	Brown		2

J8 (Harness C12R: 103-3846-)**

No.	Signal Name	Color	Other Side	No.
1	V24	White	Feeder roller right clutch D0B	1
2	OUT	Brown		2
3	V24	White	Cutter right clutch D1B	1
4	OUT	Red		2
5	-	-	-	-
6	V24	White	Feeder roller right brake D2B	1
7	OUT	Orange		2
8	V24	White	Cutter right brake D3B	1
9	OUT	Yellow		2

J21 (Harness C12R: 103-3846-)**

No.	Signal Name	Color	Other Side	No.	No.	Signal Name	Color	Other Side	No.
1	V24	White	Film pinch right close B5	1	13	V24	White	Film up/down lower right B5	10
2	-	-		-	14	-	-		-
3	S	Brown		2	15	S	Green		11
4	GND	Black	3	16	GND	Black	12		
5	V24	White	Film pinch right opening B5	4	17	V24	White	Film width detection right B5	11
6	-	-		-	18	-	-		-
7	S	Orange		5	19	S	Blue		12
8	GND	Black	6	20	GND	Black	13		
9	V24	White	Film up/down upper right B5	7	21	V24	White	Cutter original point right B5B	+
10	-	-		-	22	-	-		-
11	S	Yellow		8	23	S	Purple		OUT
12	GND	Black		9	24	GND	Black		-

J9, J10, J11 (Harness C6 DC drive R: 103-3948-)**

No.	Signal Name	Color	Other Side	No.
J9B 1		White	Film retention solenoid right 38W3	1
2		Brown		2
3	-			
4	-			
5	-			
6		White	Front film feeder right FCFR	1
7		Orange		2
8		White		3
9		Brown		4
J11B 1		White		5
2		Brown		6
3				
4				
5		White	Rear film feeder right FCBR	1
J10B 1		Yellow		2
2		White		3
3		Red		4
4		White		5
5		Red		6

J12 (Harness C4 board power supply: 103-3943-)**

No.	Signal Name	Color	Other Side	No.
1	P-858B J12	Red	f25	-
2		White	f24	-
3		Black	f26	-

J13, J14 (Harness C3 lift switch: 108-0466-)**

No.	Signal Name	Color	Other Side	No.
J13 1	P-858B J13	Brown	Lift switch motor (M4)	1
2		Red		2
J14 1	P-858B J14	-		-
2		Orange		3

J23 (P-857 J16: Harness IONET: 040-6839-)**

No.	Signal Name	Color	Other Side	No.
J15 1	P-858B J15	Brown	Discharge motor (M6)	1
2		Red		3
J16 1	P-858B J16	Brown	Discharge motor (M7)	1
2		Red		3

J22 (Harness C7 sensor: 103-3847-)**

No.	Signal Name	Color	Other Side	No.	No.	Signal Name	Color	Other Side	No.
1	-	-	-	-	13	V24	White	Lift head position sensor front	+
2	-	-	-	-	14	-	-		-
3	S	Brown	Door switch front right DR-F	1	15	S	Green		OUT
4	GND	Black		2	16	GND	Black		-
5	V24	White	Lift head position sensor rear	+	17	-	-	-	
6	-	-		-	18	-	-	-	
7	S	Orange		OUT	19	S	Brown	Door switch upper right DR-T	1
8	GND	Black	-	20	GND	Black	2		
9	V24	White	Lift head position sensor middle	+	21	-	-	-	
10	-	-		-	22	-	-	-	
11	S	Yellow		OUT	23	S	Brown	Door right switch DR-S	1
12	GND	Black	-	24	GND	Black	2		

* The sensor is a photo-interrupter (transparent): 012-8583 -**. (OMRON: EE-SX671)

J24 (Harness relay assy.: 103-3843-)**

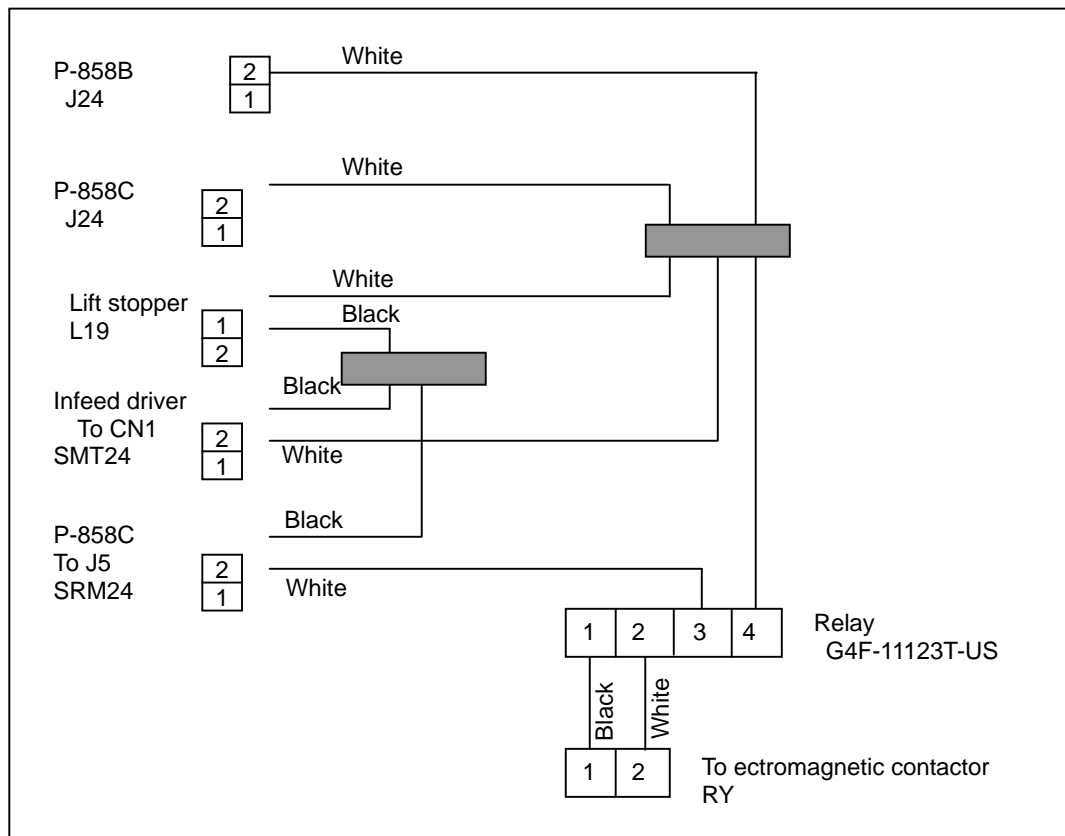

11.5 WRAPPER I/O BOARD (P-858A-*) C TYPE

This board controls input and output signals from the wrapper main board. It controls IONET communication, roll retention motor (L/R), and other drives related to the right film. It is located in the left side cover.



Note 1: Settings of the DIP switch on the board are different for each P-858* installation location (A/B/C).

For "C" type, set the DIP switch on the board as follows.

Dip Switch
1: ON
2: ON
3: OFF
4: OFF

Note 2: A number is described on the version seal for P-858*.

The number 2 can only be used for P-858B and P-858C though the number 1 can be used for all positions.

● I/O Signals

J1 (Harness C2/ONET: 040-6839-) Refer to P-858A J23.**

J3 (Harness S2 earth: 040-6856-) Refer to P-858A J23.**

No.	Signal Name	Direction	Other Side	No.
1	FG	-	Frame ground	

J4 (Harness C2 24V: 076-1888-) Refer to P-858A J5.**

J5 (Harness C2 24V: 103-3836-) Refer to P-858A J5.**

No.	Signal Name	Direction	Other Side	No.
1	V24	White	Relay AS SRM24	1
-	-	-		-
3	G24	Black		2

* Harness of 108-0270-** includes J6, J7, J8, and J21.

J6 (Harness C12L: 108-0270-) Refer to P-858A J5.**

No.	Signal Name	Color	Other Side	No.
1	OUT1	Red	Film pinch motor L DC0	1
2	-	-		-
3	OUT2	Brown		2

J7 (Harness C12L: 108-0270-)**

No.	Signal Name	Color	Other Side	No.
1	OUT1	Red	Film up/down motor L DC1	1
2	-	-		-
3	OUT2	Brown		2

J8 (Harness C12L: 108-0270-)**

No.	Signal Name	Color	Other Side	No.
1	V24	White	Feeder Roller left clutch	1
2	OUT	Brown	D0C	2
3	V24	White	Cutter left clutch	1
4	OUT	Red	D1C	2
5	-	-	-	-
6	V24	White	Feeder roller left brake	1
7	OUT	Orange	D2C	2
8	V24	White	Cutter left brake	1
9	OUT	Yellow	D3C	2

J21 (Harness C12L: 108-0270-)**

No.	Signal Name	Color	Other Side	No.	No.	Signal Name	Color	Other Side	No.
1	V24	White	Film pinch left close C1	1	13	V24	White	Film up/down lower left C1	10
2	-	-		-	14	-	-		-
3	S	Brown		2	15	S	Green		11
4	GND	Black		3	16	GND	Black		12
5	V24	White	Film pinch left opening C1	4	17	V24	White	Film width detection left C1	11
6	-	-		-	18	-	-		-
7	S	Orange		5	19	S	Blue		12
8	GND	Black		6	20	GND	Black		13
9	V24	White	Film up/down upper left C1	7	21	V24	White	Cutter original point left B5C	+
10	-	-		-	22	-	-		-
11	S	Yellow		8	23	S	Purple		OUT
12	GND	Black		9	24	GND	Black		-

J9 (Harness C2 DC drive: 108-0131-)**

No.	Signal Name	Color	Other Side	No.
1	24V	White	Film retention solenoid left 38W3	1
2	OUT	Brown		2
3-9 are not used.				

J10, J11 (Harness C5 DC drive L: 103-3949-). Refer to P-858A J9.**

No.	Signal Name	Color	Other Side	No.
P-858A J1 1	-	-	Not used	-
2	-	-		-
3	-	-		-
4	-	-		-
5	-	-		-
6		White		Front feeder left (each solenoid and fan)
7		Orange	FCFL connector (16P)	2
8		White	Rear feeder left (each solenoid and fan)	1
9		Yellow	FCBL connector (16P)	2
P-858C J11 1		White	Front feeder left (each solenoid and fan)	3
2		Brown	FCFL connector (16P)	4
3	-	-	Not used	-
4		White	Rear feeder left (each solenoid and fan)	3
5		Red	FCBL connector (16P)	4
P-858C J10 1		White	Front feeder left (each solenoid and fan)	5
2		Brown	FCFL connector (16P)	6
3	-	-	Not used	-
4		White	Rear feeder left (each solenoid and fan)	5
5		Red	FCBL connector (16P)	6

Note: FCFL/FCBL connector is composed of the above-mentioned connector (P-858C J10, J11) and P-858A J9.

J12 (Harness C8 board power supply: 103-3942-). Refer to P-858A J12.****J13 (Harness C2 roll retention: 076-9603-**)**

No.	Signal Name	Color	Other Side	No.
1		Brown	To roll retention motor L M5 L	1
2		Red		3

J14 (Harness C2 roll retention: 076-9603-)**

No.	Signal Name	Color	Other Side	No.
1		Brown	To roll retention motor R M5 R	1
2		Red		3

J22 (Harness C7 safety switch: 103-3849-)**

No.	Signal Name	Color	Other Side	No.	No.	Signal Name	Color	Other Side	No.
1	-	-	Door switch Printer D-PRT	-	13	-	-	Door switch Side left D-LS	-
2	-	-		-	14	-	-		-
3	S6	Brown		1	15	S9	Brown		1
4	GND	Black		2	16	GND	Black		2
5	-	-	Emergency stop EST	-	17	-	-	Door switch Front left D-LF	-
6	-	-		-	18	-	-		-
7	S7	Brown		1	19	S10	Brown		1
8	GND	Black		2	20	GND	Black		2
9	-	-	Door switch Upper left D-LT	-	21	-	-	Door switch Front middle D-FM	-
10	-	-		-	22	-	-		-
11	S8	Brown		1	23	S11	Brown		1
12	GND	Black		2	24	GND	Black		2

J24 (Harness relay assy.: 103-3843-). Refer to J24 P-858B.**

11.6 EMERGENCY STOP BUTTON (IDEC'2B[HW1B-V402R]:064-9296-**))

- I/O Signals

(Harness C7 emergency stop: 108-0274-**))

No.	Signal Name	Color	Other Side	No.
1Y	Contact type No monitoring	Orange	Via EST junction connector To P-858C J22 S7	1
2	GND	Yellow		2
1	-	Brown	Safety cover switch Printer front cover	2
		Black	PRT → P-858C J22 S6	1
		Black	Safety cover switch Printer front cover	1
2Y		Red	PRT → P-858C J22 S6	2

11.7 SAFETY COVER SWITCH

● Block diagram

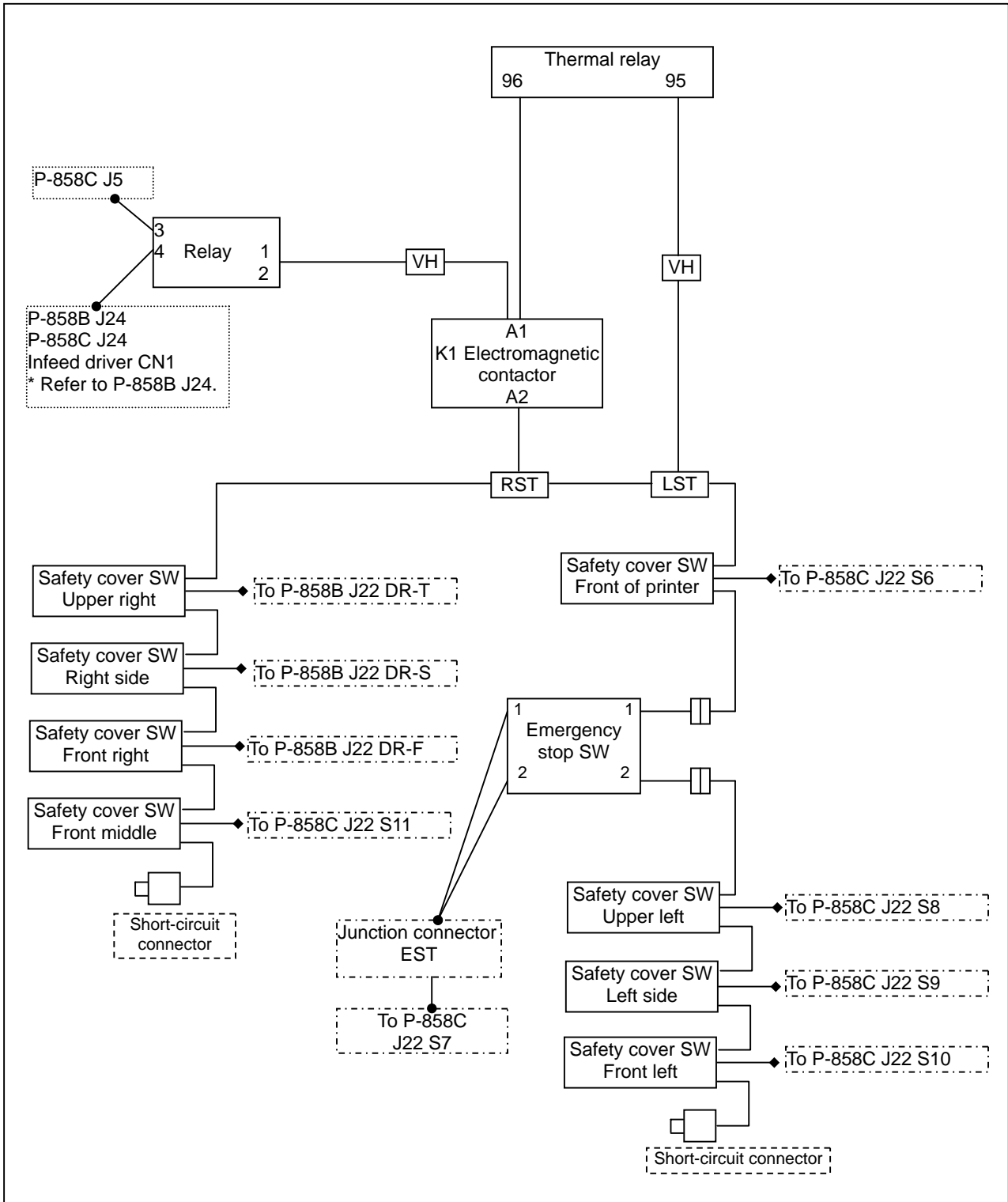

11.8 SAFETY SWITCH ASSY. (091-0690-**)

Safety switch IDEC (single unit): 072-2080 -**

No.	Color
1	Brown
2	Red
3	Orange
4	Yellow

11.9 DISCHARGE PUSHER

Discharge controller inputs AC200V from the terminal block, and communicates with P-857 J5 and J6.

- Block diagram

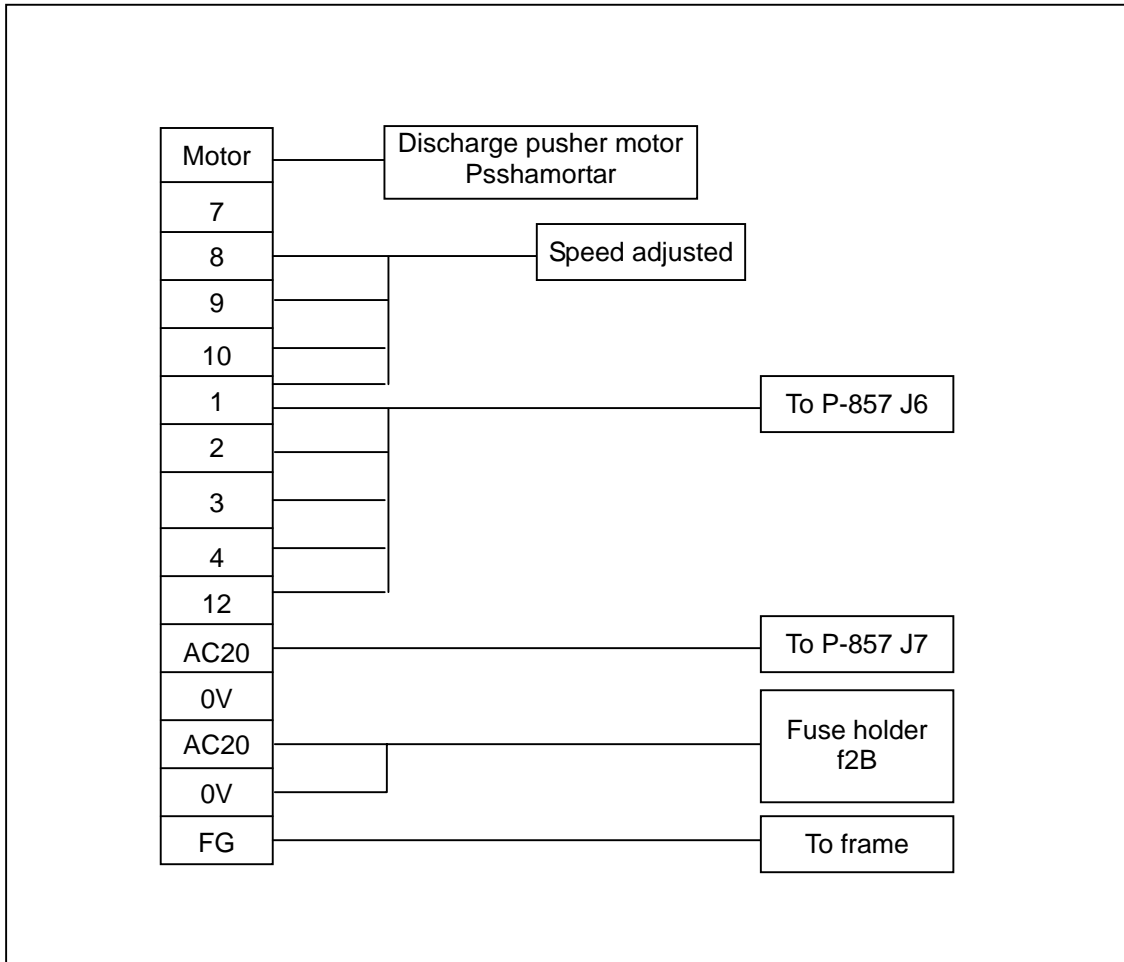

11.10 THERMAL PC BOARD (P-909C-3)

This board controls the printer. It is jointed on the main PC board.

Program downloading is required after the board has been replaced because this is activated by the data downloaded from program "CF".

*Note: One thermal PC board is necessary for one printer.
Two thermal PC boards are needed for two printer specification.
Moreover, jumper switch settings (JP3, JP7) are different for two printer specification.*

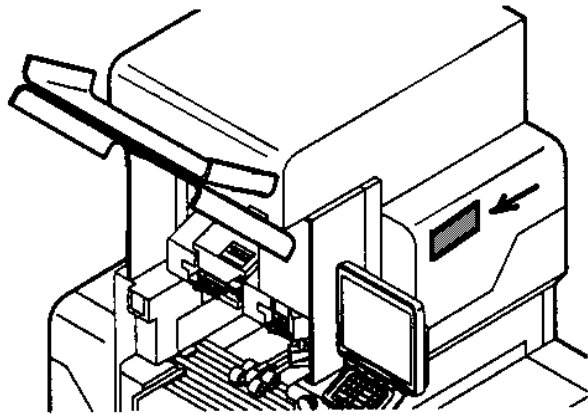

Set the jumper switches as follows:

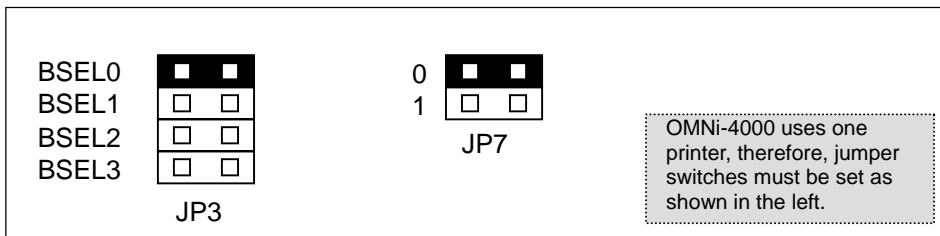

• PC board of the first printer

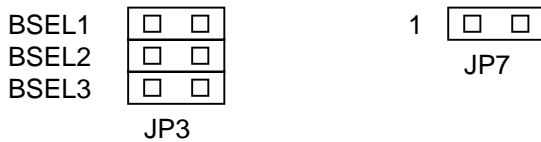

• PC board of the second printer

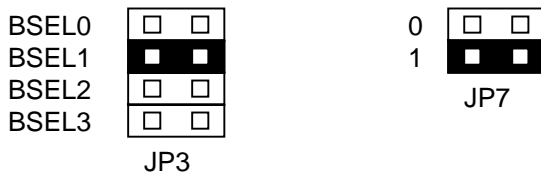

Note: Set the DIP switch (S1) on the PC board to all "OFF".

I/O signal

XJ1

No.	Signal name	Direction	Other side
A1 - A26 B1 - B26	Signal between P-909 and P-909	←→	First printer (Second printer) P-909 (XJ1)

Note: Used for two printer specification.

XJ3, XJ7 (Harness C4 motor junction: 071-4551-**)

No.	Signal name	Color	Direction	Other side	No.
XJ3 1	\overline{B} phase	Brown	→	Junction connector X100-P1 Stepping motor for label feeding	1
2	B phase	Red	→		2
3	\overline{A} phase	Orange	→		3
4	A phase	Yellow	→		4
5	B COM	Green	-		5
6	A COM	Blue	-		6
XJ7 2	DC+24[V]	Purple	-	Junction connector X100-P1 DC motor for paper take up	1
1	GND	Gray	→		3

X101-P1~ (Motor assy. paper take up: 072-5467-**)

No.	Signal name	Color	Other side
1	DC+24[V]	Brown	24V DC motor for paper take up
2	-	-	
3	GND	Red	

X100-P1~ (Motor assy. stepping: 092-8406-**)

No.	Signal name	Color	Other side
1	\overline{B} phase	Tiao	24V DC stepping motor
2	B phase	Red	
3	\overline{A} phase	Green	
4	A phase	Black	
5	B COM	White	
6	A COM	Yellow	

XJ6 (Harness S2 thermal head: 069-6673-**)

No.	Signal name	Direction	Other side
1·3·5·7·9·11	GND	-	To thermal head via P-925 thermal junction board XJ1
2·4·6·8·10	DC+24[V]	→	
13	DC+5[V]	→	
12·14 - 34	Thermal head control signal	←→	

XJ7 (Refer to P-909 XJ3)

XJ9 (Harness S2 power supply junction: 063-8454-**)

No.	Signal name	Color	Direction	Other side	No.
1	DC+24[V]	Brown	→	P-910 (XJ6)	1
2	GND	Red	-		2

XJ10 (Harness S2 power supply 24V:069-6674-)**

No.	Signal name	Color	Direction	Other side	No.
1	DC+24[V]	White	←	Switching power supply (CN5) (CN6) for 2 nd printer	1
2	DC+24[V]	White	←		2
3	DC+24[V]	White	←		3
4	GND	Black	-		4
5	GND	Black	-		5
6	GND	Black	-		6

XJ13, XJ14, XJ16 (Harness C5 sensor junction: 071-4550-)**

No.	Signal name	Color	Direction	Other side	No.
XJ13 1	Power supply for receiver of peel sensor (black)	Brown	→	Peel sensor relay bracket X103-P1	9
4	Peel sensor input signal (receiver side)	Red	←		10
2	GND (emitter)	White	-	Sensor junction bracket X102-P1 Peel sensor emitter Label sensor receiver (black) Label sensor emitter (red) Head-up sensor Switch lead magnet	2
3	Power supply for emitter of peel sensor (Gray)	Black	→		3
XJ14 1	Power supply for receiver of label sensor	Orange	→		3
2	GND (emitter)	Yellow	-		4
3	Power supply for emitter of label sensor	Green	→		5
4	Label sensor input signal (receiver)	Blue	←		6
XJ16 1	Head-up sensor input signal	Brown	←		1
2	GND	Red	-		2

XJ18 (for complementary sensor)**X102-P1~ (Sensor assy,:098-8086-**)**

No.	Signal name	Color	Other side	No.
1		Brown	Head-up sensor relay M100	1
2		Red		2
3		Orange	Label sensor emitter (red)	C
6		Blue		E
4		Yellow		K
5		Green	Label sensor receiver (blue)	A
7		Purple		-
8		Gray	Not used	-
9		White		-
		White	Peel sensor emitter (gray)	3
10		Black		1

X103-P1~ (Harness C2 sensor junction: 071-4549-)**

No.	Signal name	Color	Signal name	Other side	No.
1		Black	C	Peel sensor receiver (black)	1
2		Black	E		3

XJ100

No.	Signal name	Direction	Other side
A1 - A60 B1 - B60	Signal between P-909 and P-910	↔	P-910 (XJ3)

B100: Head-up sensor (098-8087-**)

2P connector-proximity switch: RS-901S (067-2608-**)

B101: Head-up sensor magnet (067-2609-**) Proximity switch: RS-901M

11.11 APPLICATOR CONTROL PC BOARD (P-916B)

This board controls the applicator. It is located in the top cover of the main body.

Program downloading is required after the board has been replaced because this is activated by the data downloaded from program "CF".

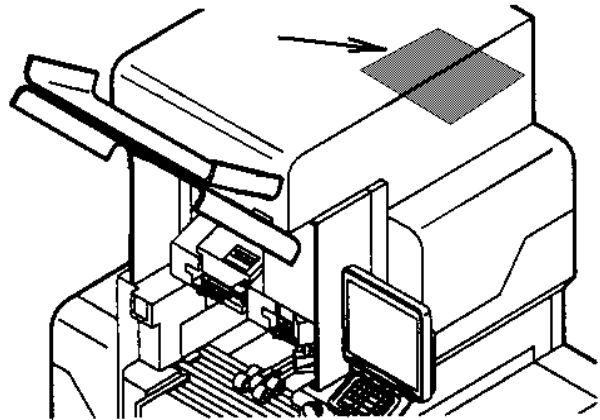

- **Main storage data**
 - Suction position data
 - Pasting position data
- **Work after PC board replacement**
 - Initialize the applicator.
 - Confirm the suction and pasting positions.



The suction position data and the pasting position data are memorized in the PC board of the applicator. Moreover, it is backed up in the program CF of the main control PC board (P-910) (file name: Haridata.csv). You will receive an inquiry whether to restore data in the program CF when the applicator PC board is initialized.

DIP Switch Settings

Switch No.	1	2	3	4
S1	OFF	OFF	OFF	OFF

I/O signal

XJ1, XJ8, XJ9 (Harness C6 motor operation X: 079-3007-**)

No. ring	(A) Terminal No.	Wire No.	Wire/Spiral color	(D) Terminal No.	No. ring	Signal name	Wire No.		
A51-XJ9	1	1	Black/None	1	M52	B	Motor Y		
	2	2	White/None	2		B			
	3	3	Red/None	3		A			
	4	4	Green/None	4		A			
	5	5	Yellow/None	5		BCOM			
	6	6	Brown/None	6		ACOM			
	(B) Terminal No.			(E) Terminal No.					
A51-XJ8	1	7	Blue/None	1	X55	B	Motor Z		
	2	8	Gray/None	2		B			
	3	9	Orange/None	3		A			
	4	10	Light blue/None	4		A			
	5	11	Black/Pink	5		BCOM			
	6	12	White/Black	6		ACOM			
	(C) Terminal No.			(F) Terminal No.					
A51-XJ1	1	13	Red/Black	1	X56	B	Motor rotation		
	2	14	Green/Black	2		B			
	3	15	Yellow/Black	3		A			
	4	16	Brown/Black	4		A			
	5	17	Blue/Black	5		BCOM			
	6	18	Gray/Black	6		ACOM			
		Blank	19	Orange/Black		Blank			
		Blank	20	Light blue/Black		Blank			

XJ3, XJ20, XJ21, XJ24, XJ25 (Harness C8 sensor operation X:079-3009-))**

No. ring	(A) Terminal No.	Wire No.	Wire/Spiral color	(F) Terminal No.	No. ring	Signal name	Wire No.
A51-XJ3	1	1	Black/None	1	M61	FAN	Fan suction
	2	2	White/None	2		GND	
	(B) Terminal No.						
A51-XJ20	2	3	Red/None	3		Vcc	Pasting sensor
	3	4	Green/None	4		Out	
	4	5	Yellow/None	5		GND	
	7	6	Brown/None	6		C	Sensor label check
	8	7	Blue/None	7		E	
	9	8	Gray/None	8		A	
	10	9	Orange/None	9		K	
	(C) Terminal No.						
	6	10	Light blue/None	10		Vcc	Middle sensor Z
	7	11	Black/Pink	11		Out	
	8	12	White/Black	12		GND	
	(D) Terminal No.						
A51-XJ24	2	13	Red/Black	13		Vcc	Sensor rotation (right)
	3	14	Green/Black	14		Out	
	4	15	Yellow/Black	15		GND	Sensor rotation (left)
	6	16	Brown/Black	16		Vcc	
	7	17	Blue/Black	17		Out	
	8	18	Gray/Black	18		GND	
	(E) Terminal No.			(G) Terminal No.			
A51-XJ25	2	19	Orange/Black	1	X62	Vcc	Sensor Y (front)
	3	20	Light blue/Black	2		Out	
	4	21	Black/Red	3		GND	Sensor Y (rear)
	6	22	White/Red	4		Vcc	
	7	23	Red/Pink	5		Out	
	8	24	Green/Red	6		GND	
	(C) Terminal No.			(H) Terminal No.			
A51-XJ21	2	25	Yellow/Red	1	X60	Vcc	Sensor Z (upper)
	3	26	Brown/Red	2		Out	
	4	27	Blue/Red	3		GND	

XJ4 (Fan assy.:090-5391-))**

No.	Signal name	Color	Direction	Other side
1	OUT	Red	→	Cooling fan
2	GND	Black	-	

XJ5 (motor assy. stepping: 079-3002-))**

No.	Signal name	Color	Direction	Other side
1	B#	Blue	←	X axis motor
2	B	Red	←	
3	A#	Green	←	
4	A	Black	←	
5	BCOM (DC+24[V])	White	→	
6	ACOM (DC+24[V])	Yellow	→	

XJ8 (Refer to XJ1) and XJ9 (Refer to XJ1))

XJ11, XJ17 (harness C3 console IF:072-8552-)**

No.	Signal name	Color	Direction	Other side	No.
XJ11 1	OUT+	Purple	←	Console communication To RS485 X271	1
2	OUT-	Gray	←		2
XJ17 1	OUT+	Brown			3
2	OUT-	Red			4
3	OUT+	Orange			5
4	OUT-	Yellow			6
5	SG	Green			7
6	FG	Blue			8

XJ13 (Harness C2 earth: 072-2104-28)

No.	Signal name	Direction	Other side
1	FG	-	Frame gland

XJ15 (not used), XJ16 (not used), XJ17 (Refer to P-916 XJ11)**XJ18 (Harness C5 external signals: 103-3934-**)**

No.	Signal name	Color	Direction	Other side	No.
1	-		-	Applicator safety sensor Right emitter	-
2	VCC(DC+5[V])	Red	→		1
3	-		-		-
4	GND	Black	-	Applicator safety sensor Left receiver	2
5	-		-		1
6	VCC(DC+5[V])	Red	→		2
7	OUT	Orange	←	To the electromagnetic contactor via X9.	3
8	GND	Black	-		-
9	-		-	Pasting timing signal (P-857 J5)	-
10	-		-		-
11	OUT	Brown	←		1
12	GND	Black	-	Pasting timing signal (P-857 J5)	2
13	-		-		-
14	-		-		-
15	OUT	Green	←		3
16	GND	Black	-		2

XJ19, XJ22 (Harness C6 sensor X:079-3005-)**

No.	Signal name	Color	Direction	Other side	No.
XJ19 1	-	-	-	B54 connector X printer 2 Sensor	-
2	VCC (DC+5[V])	Red	→		3
3	OUT	Green	←		2
4	GND	Black	-		1
XJ22 1	-	-	-	B51 connector Right limit of sensor X	-
2	VCC (DC+5[V])	Red	→		3
3	OUT	Brown	←		2
4	GND	Black	-	B52 connector Sensor X Printer 1	1
5	-	-	-		-
6	VCC (DC+5[V])	Red	→		3
7	OUT	Orange	←		2
8	GND	Black	-	B53 connector Left limit of sensor X	1
9	-	-	-		-
10	VCC (DC+5[V])	Red	→		3
11	OUT	Yellow	←		2
12	GND	Black	-		1

XJ20 (Refer to XJ3)
 XJ21 (Refer to XJ3)
 XJ22 (Refer to XJ19)
 XJ23 (Not used)
 XJ24 (Refer to XJ3)
 XJ25 (Refer to XJ3)

XJ27 (Harness C2 DC power supply: 103-3933-)**

No.	Signal name	Color	Direction	Other side	No.
1	VH(DC+24[V])	White	←	To P-918 XJ7	3
2	-	-	-		-
3	-	-	-		-
4	-	-	-		-
5	-	-	-		-
6	GND	Black	-		1

XJ28 (Harness S2 power supply motor: 090-5392-)**

No.	Signal name	Color	Direction	Other side	No.
1	VH(DC+24[V])	White	←	Applicator power supply CN5	1
2	VH(DC+24[V])	White	←		2
3	VH(DC+24[V])	White	←		3
4	GND	Black	-		4
5	GND	Black	-		5
6	GND	Black	-		6

M52 Motor assy. stepping Y (079-3003-)**

No.	Signal name	Color	Other side
1	\bar{B}	Blue	Front/Rear applicator motors Model: Oriental PK264-02A-C45
2	B	Red	
3	\bar{A}	Green	
4	A	Black	
5	BCOM	White	
6	ACOM	Yellow	

M53 Motor assy. stepping Z (077-0000-)**

No.	Signal name	Color	Other side
1	\bar{B}	Blue	Upper/Lower applicator motors Model: Oriental C8841-9212H
2	B	Red	
3	\bar{A}	Green	
4	A	Black	
5	BCOM	White	
6	ACOM	Yellow	

M54 Motor assy. stepping rotation (079-3001-)**

No.	Signal name	Color	Other side
1	\bar{B}	Blue	Applicator rotation motor Model: Oriental PK243-01A-C132
2	B	Red	
3	\bar{A}	Green	
4	A	Black	
5	BCOM	White	
6	ACOM	Yellow	

X65 Fan assy. suction (094-0414-)**

No.	Signal name	Color	Other side
1	X 65 Junction connector	Light blue	Suction fan
5		Gray	Suction fan
4		Orange	Label existence sensor
3		Light green	
2		Pink	

1-K
2-A
3-E
4-C

X64 Harness C3 sensor operation Z (079-1443-)**

No.	Signal name	Color	Other side	Signal name	No.
1	Vcc	White	X65 Junction connector	FAN	1
2	Out	Yellow		C	2
3	FAN	Green		E	3
4	C	Blue		A	4
5	A	Red		K	5
6	GND	Black	B60 Pasting detection sensor	GND	1
7	GND	Brown		Out	2
8	GND	Orange		Vcc	3

X63 Harness C5 sensor Z rotation (079-3004-)**

No.	Signal name	Color	Other side	No.
1	Vcc	Red	B61 Sensor Z upper	3
2	Out	Yellow		2
3	GND	Black		1
4	Vcc	Red	B57 Sensor Z middle	3
5	Out	Gray		2
6	GND	Black		1
7	Vcc	Red	B58 Sensor rotation left	3
8	Out	Brown		2
9	GND	Black		1
10	Vcc	Red	B59 Sensor rotation left	3
11	Out	Orange		2
12	GND	Black		1

X62 Harness C3 sensor Y (079-3006-)**

No.	Signal name	Color	Other side	No.
1	Vcc	Red	B55 Sensor Y rear	3
2	Out	Blue		2
3	GND	Black		1
4	Vcc	Red	B56 Sensor Y front	3
5	Out	Purple		2
6	GND	Black		1

11.12 CONTROL CONSOLE PC BOARD (P-917-1)

This board is located in the display unit.

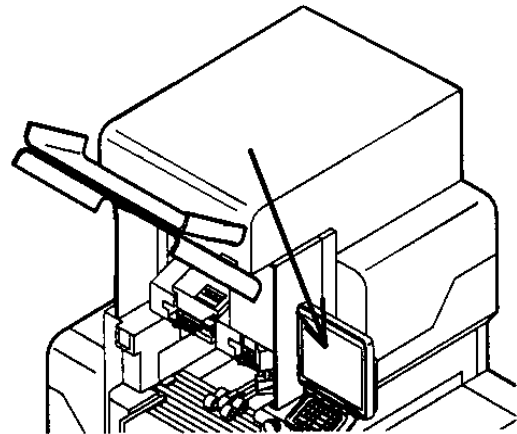

I/O signal

XJ1 (Harness C2 inverter: 098-3155-**)

No.	Signal name	Color	Direction	Other side	No.
1	12V	White		To inverter PC board CN1	7
2	12V	White			6
3	12V	White			3
4	GND	Black			5
5	GND	Black			4
6	VR_2	Red			2
7	VR_1	Orange			1

XJ7 (Option: To preset keys)

XJ8 (Harness C2 numeric keys junction: 069-6731-**)

No.	Signal name	Direction	Other side
1 - 14	Keyboard control signal	←	Relay X280 and to the keyboard

XJ9 (Harness C4 touch panel)

No.	Signal name	Direction	Other side
1 - 4	Touch panel control signal	←	Touch panel

XJ11 Option: To scanner and preset keys

XJ12, XJ14, XJ19 (Harness C4 TFT:098-3156-)**

Ⓐ P-917 XJ14	1	Blue 150	11	R5	Ⓣ TFT CN1		
	2	Black 150	10	R4			
	3	Black 150	9	R3			
	4	Black 150	18	G5			
	5	Black 150	23	G3			
	6	Black 150	8	A2			
	7	Black 150	7	A1			
	8	Black 150	15	G2			
	9	Black 150	28	VCC			
	10	Black 150	1	GND			
Ⓑ P-917 XJ12	1	White 150	4	VSYNC	Ⓣ TFT CN1		
	4	Black 150	3	HSYNC			
	5	Black 150	19	GND			
	7	Black 150	26	GND			
	8	Black 150	17	G4			
	9	Black 150	16	G3			
	10	Black 150	25	B5			
	11	Black 150	24	B4			
	12	Black 150	14	G1			
	13	Black 150	27	DE			
	14	Black 150	22	B2			
	15	Black 150	21	B1			
	Ⓒ P-917 XJ19	1	White 170	29		VCC	Ⓣ TFT CN1
		2	Black 170	5		GND	
		3	Black 170	6		R5	
4		Black 170	12	GND			
5		Black 170	2	GLK			
6		Black 170	13	GO			
7		Black 170	20	BO			

XJ13 (Harness S2LVDS:098-4167-)**

No.	Signal name	Direction	Other side
1 - 26	LCD control signal RS-232C DC+12[V]	-	P-919 (XJ2)

XJ14 (Refer to P-917 XJ12)

XJ17 (Harness S2 volume: 098-8130-)**

No.	Signal name	Color	Direction	Other side
1	LCD contrast adjustment VR	White	-	LCD volume
2	LCD contrast adjustment VR	Black	-	

XJ19 (Refer to P-917 XJ12)

11.13 CONNECTOR RELAY PC BOARD (P-918A-1)

This board connects the I2NET and optional devices.
It is located in the right side cover of the main body,

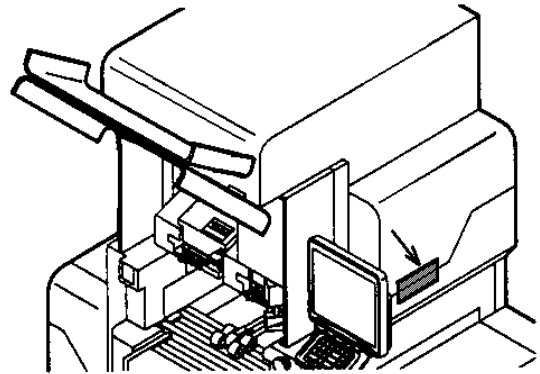

I/O signal

XJ2, XJ8, XJ9, XJ11 (Harness C6 RS 3964 485:103--**)

No.	Signal name	Color	Direction	Other side	No.
XJ2 1	DC+5[V]	Brown	→	Via X271	1
2	Applicator label issue timing signal	Red	←		2
XJ8 1	Not used		-		-
2	Not used		-		-
3	DC+5[V]	Orange			3
4	Applicator state inquiry request signal	Yellow			4
5	RS-485 D	Green			5
6	RS-485 \bar{D}	Blue			6
7	GND	Purple		7	
8	FG	-	-	8	
XJ9 1	-	-	-	To P-857 (XJ14, XJ15) via X270	-
2	OUT-				2
3	-	-	-		-
4	-	-	-		-
5	-	-	-		-
6	-	-	-		-
7	-	-	-		-
8	-	-	-		-
XJ11 1	D+		-		3
2	D	Yellow	-		4
3	-	Green	-	-	
4	-	Red	-	-	
5	SG	Black	-	5	
6	FG	White	-	6	

Note: Refer to P-910 XJ7 for XJ4 (Harness C2 peripheral INT1: 069-4847-**).

Refer to P-910 XJ1 for XJ5 (Harness C2 communication: 069-4846-**).

XJ7 (Harness C2 power supply: 103-3933-**)

No.	Signal name	Color	Direction	Other side	No.
1	VH	Black	→	P-916 XJ27	6
2	GND	White	-		1

XJ12 (Connected on the PC board with solder)

No.	Signal name	Direction	Other side	No.
1	I2NET D	↔	ILAN (Option 1)	1
2	I2NET \overline{D}	↔		2
3	I2NET EN	↔		3
4	I2NET \overline{EN}	↔		4
5	GND	-		5
6	FG	-		6

XJ13 (Connected on the PC board with solder)

No.	Signal name	Direction	Other side	No.
1	Not used	-	ELAN (In-line)	1
2	Not used	-		2
3	GND	-		3
4	I2NET EN	↔		4
5	I2NET D	↔		5
6	Not used	-		6
7	FG	-		7
8	I2NET \overline{EN}	↔		8
9	I2NET \overline{D}	↔		9

XJ14 (Connected it on the PC board with solder)

No.	Signal name	Direction	Other side	No.
1	Not used	-	ELAN (In-line)	1
2	Not used	-		2
3	GND	-		3
4	I2NET EN	↔		4
5	I2NET D	↔		5
6	Not used	-		6
7	FG	-		7
8	I2NET \overline{EN}	↔		8
9	I2NET \overline{D}	↔		9

XJ15 (Connected on the PC board with solder)

No.	Signal name	Direction	Other side	No.
1	RS232C CD	↔	ELAN (In-line)	1
2	RS232C RxD	↔		2
3	RS232C TxD	↔		3
4	RS232C DTR	↔		4
5	RS232C SG	-		5
6	RS232C DSR	↔		6
7	RS232C RTS	↔		7
8	RS232C CTS	↔		8
9	RS232C RI	↔		9

11.14 DISPLAY JUNCTION PC BOARD (P-919B-3)

This board relays the main and display PC boards.
It is located in the right side cover of the main body.

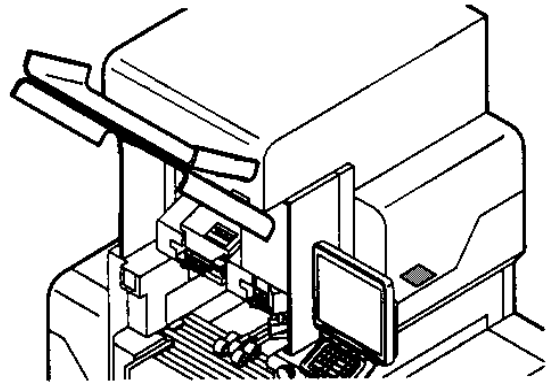

I/O signal

XJ1 (Refer to P-910 XJ10)

No.	Signal name	Direction	Other side
1·3·4·6·8 ~ 15	LCD control signal	↔	P-910 (XJ10)
2	Not used	-	
5·7	GND	-	

XJ2 (Refer to P917 XJ13)

No.	Signal name	Direction	Other side
1 ~ 26	LCD control signal RS-232C DC+12[V]	-	P-917 (XJ13)

XJ3 (Refer to P910 XJ9)

No.	Signal name	Direction	Other side
1 ~ 8	LCD control signal	↔	P-910 (XJ9)
9	DC+5[V]	←	
10	GND	-	
11 ~ 14	Not used	-	

XJ4 (Refer to P910 XJ5)

No.	Signal name	Direction	Other side
1	RS232C TxD	←	P-910 (XJ5)
2	RS232C RTS	←	
3	RS232C RxD	→	
4	RS232C CTS	→	
5	RS232C DC+5[V]	←	
6	RS232C SG	-	
7	RS232C FG	-	

XJ6 (Refer to P910 XJ11)

No.	Signal name	Direction	Other side
1	DC+12[V]	←	P-910 (XJ11)
2	GND	-	
3	Buzzer ON/OFF	←	

XJ7 (Refer to P910 XJ2)

No.	Signal name	Direction	Other side
1	DC+12[V]	←	Switching power supply (CN7)
2	GND	-	

11.15 THERMAL HEAD RELAY PC BOARD (P-925*)

This board relays from the thermal board (P-909) to the thermal head.
It is located at the side of the printer unit.

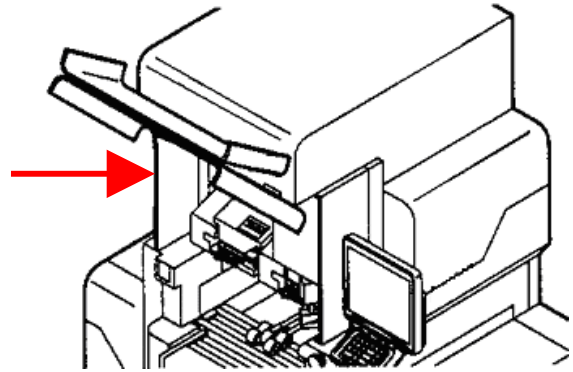

I/O signal

XJ1 (Refer to P-909 XJ6)

XJ2 (Harness C2 thermal head: 071-4583-)**

No.	Signal name	Other side	No.
1 - 26		Thermal head (LH-4114:094-0086-**)	26
27 - 34	Not used		

11.16 SCALE PC BOARD (P-930A-1)

It is located in the scale unit of the infeed unit.

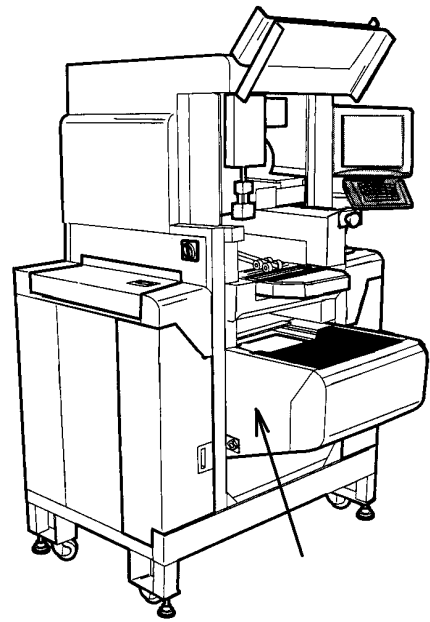

DIP Switch Settings

Switch No.	1	2	3	4	5	6	7	8
S3	OFF	OFF	OFF	OFF	OFF	OFF	OFF	OFF

DIP switch bit	Function	Contents
1	Board number	OFF: Set by command. ON: "0" fixed
2	Storage command	OFF: Command prohibition ON: Command permission
3	Test mode	OFF: Command permission ON: Command prohibition
4	Moving average	OFF: 8 times ON: None
5	Zero bias	OFF: Yes ON: No
6	Wait when transmitting	OFF: None ON: 20 msec
7	A/D data	OFF: ASC-HEX 5byte ON: ASC-HEX 6byte
8	Analog filter	OFF: Soft ON: Hard

I/O signal

XJ1, XJ4, XJ5 (Harness C4 scale communication: 071-4657-)**

No.	Signal name	Color	Direction	Other side	No.
XJ1 1	OUT+1(weighing completion signal)	Brown	←	To X292 junction connector via X291 junction connector. XJ8 of P-910 (main board)	1
2	OUT+2	-	-		
3	OUT- (weighing completion signal)	Red	←		3
XJ4 1	VEX+ (DC+12V power supply input)	White	←		6
2	GND	Black	-		7
3	VEX-	Green	-		8
4	FG	Gray	-		9
XJ5 1	D# (RS485 communication signal)	Orange	↔		4
2	D (RS485 communication signal)	Yellow	↔		5
3	TXVCC	-	-		-
4	TXGND	-	-		-
5	FG	-	-		-

XJ2 (Not used)**XJ3 (Not used)****XJ4 (Refer to P-930 XJ1.)****XJ5 (Refer to P-930 XJ1.)****XJ6 (Not used)****Connector between X291 and X292 (Harness S2 scale junction: 091-0925-**)**

No.	Signal name	Color	Other side	No.
X291 1	OUT+1(measurement completion signal)	Brown	Relay the X292 relay connector. P-910 (main board) To XJ8	1
2	OUT+2	-		-
3	OUT- (measurement completion signal)	Red		3
4	D# (RS485 communication signal)	Orange		4
5	D (RS485 communication signal)	Yellow		5
6	VH+	White		6
7	GND	Black		7
8	VH-	Green		8
9	FG	-		9

11.17 LAN PC BOARD (P-967-1)

This board connects a computer with TCP-IP. It is located in the right side cover of the main body.

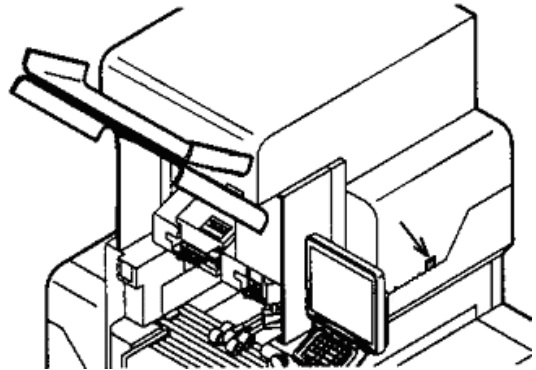

I/O signal

XJ1 (Refer to P-910 XJ18)

No.	Signal name	Direction	Other side
1	LAN TD+	←	P-910 (XJ18)
2	LAN TD-	←	
3	LAN RD+	→	
6	LAN RD-	→	
4.5.7.8	GND	-	

XJ2

No.	Signal name	Direction	Other side
1	LAN TX+	→	LAN
2	LAN TX-	→	
3	LAN RX+	←	
6	LAN RX-	←	
4.5.7.8	GND	-	

11.18 SW POWER SUPPLY (DL912W) U220

This board is located on the right side of the main body.

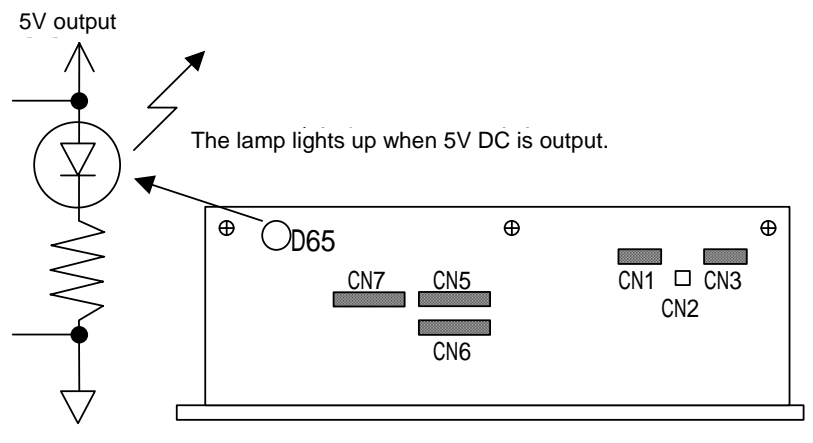
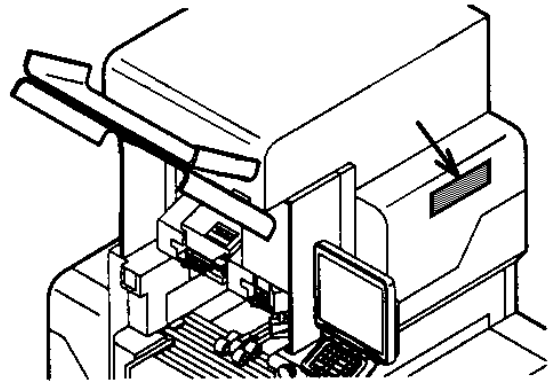

Settings of 200V input specification

Connect the PN3 harness with PN1.
PN2 is not connected.



WARNING

When 200 voltage is applied to the 100V specification, the switching power supply will be damaged. Confirm the specified power-supply voltage.

I/O signals**CN1 (Not used: 3P)****CN2 (Not used: 2P)****CN3 (AC200V power supply)**

No.	Signal name	Direction	Other side
2	AC200[V]	←	Fuse
5	AC200[V]	←	
1,3,4	Not used		

CN5 (Refer to P-910 XJ10.)

No.	Signal name	Direction	Other side
1 - 3	DC24[V]	→	First printer
4 - 6	GND	-	P-909 (XJ10)

CN6 (Second printer specification: To XJ2 of P-910)**CN7 (Refer to XJ2 of P-910 and XJ7 of P-919)**

No.	Signal name	Direction	Other side
1	DC+5[V]	→	P-910 (XJ2)
2	DC+12[V]	→	P-910 (XJ2), P-919 (XJ7)
3	Not used		
4	GND	-	P-910 (XJ2)
5	GND	-	P-910 (XJ2), P-919 (XJ7)

11.19 SW POWER SUPPLY (DL912W-1) U51

This board is located in the top cover of the main body. (Not mounted in the manual labeling specification)

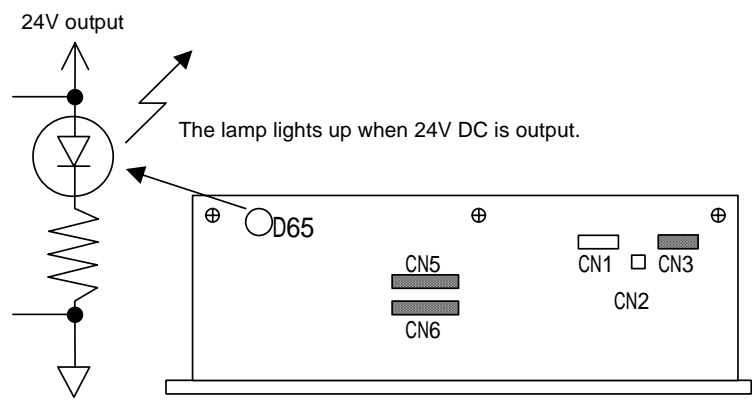
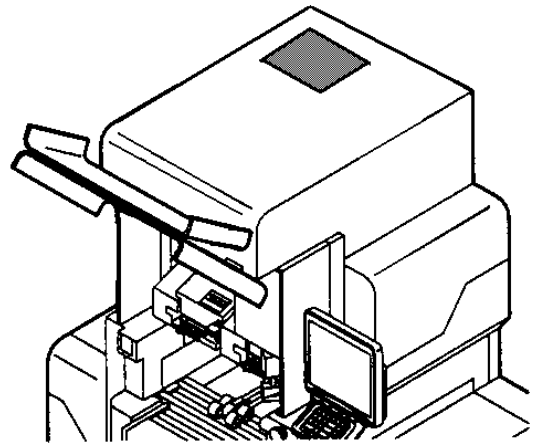

Settings for 200V specification

Connect the harness connected with PN3 to PN1.
PN2 is not connected.



WARNING

When 200 voltage is applied to the 100V specification, the switching power supply will be damaged. Confirm the specified power-supply voltage.

I/O signals

CN1 (Not used: 3P)

CN2 (Not used: 2P)

CN3

No.	Signal name	Direction	Other side
2	AC200[V]	←	To fuses F51 and F52
5	AC200[V]	←	
1,3,4	Not used		

CN5 (Refer to P-916 XJ28.)

No.	Signal name	Direction	Other side
1 ~ 3	DC24[V]	→	P-916 (XJ28)
4 ~ 6	GND	-	

CN6 (Not used: 6P)

12

DIAGRAMS

CONTENTS

12.1 APPEARANCE DIAGRAM.....	12-2
12.2 WIRING DIAGRAM.....	12-3
12.3 CONTROL WIRING DIAGRAM.....	12-4

12.1 APPEARANCE DIAGRAM

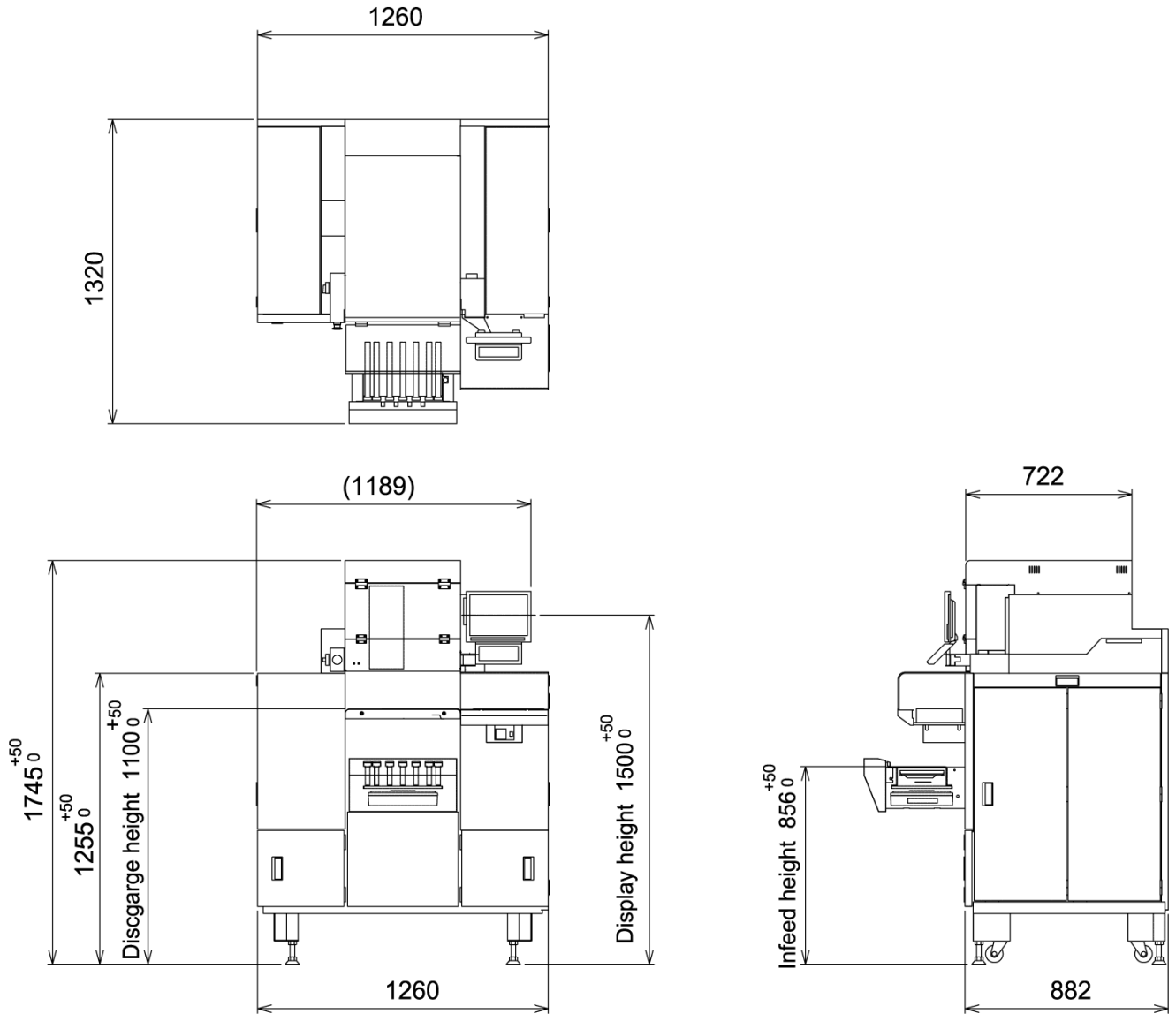

TITLE
Appearance Diagram
DWG.No.
108-8182-06

12.2 WIRING DIAGRAM

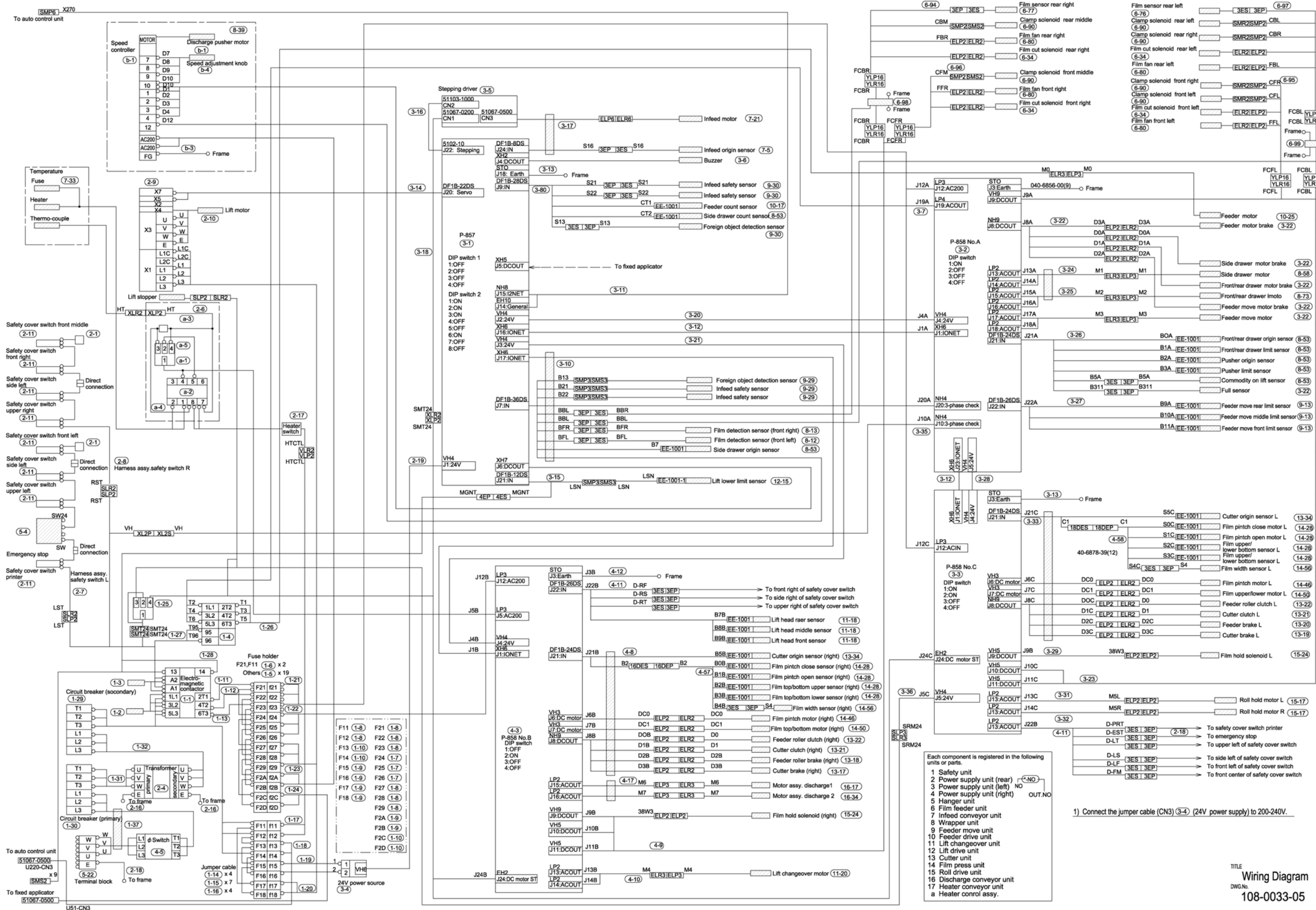

TITLE
Wiring Diagram
DWG.No.
108-0033-05

12.3 CONTROL WIRING DIAGRAM

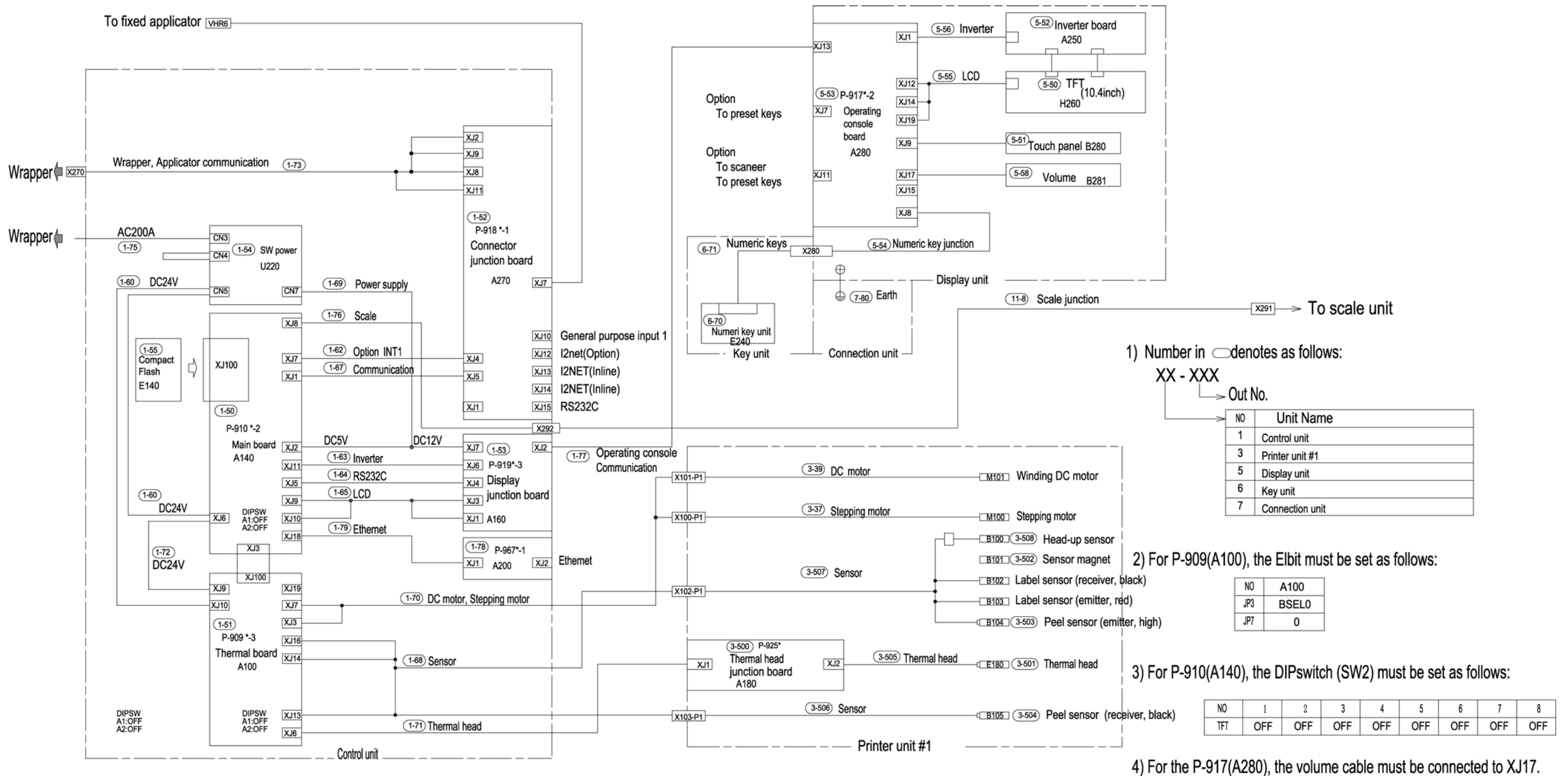

TITLE
Control Wiring Diagram
 DWG.No.
108-8042-08

13

PARTS LIST & DIAGRAMS

CONTENTS

13.1	RECOMMENDED INDENTORY PARTS LIST	13-2
13.2	PREVENTIVE MAINTENANCE PARTS LIST	13-7
13.3	CONNECTION ASSEMBLY DIAGRAM	13-31
13.4	INSIDE COVER ASSEMBLY DIAGRAM.....	13-32
13.5	FILM PRESS ASSEMBLY DIAGRAM	13-33
13.6	TRAY STOPPER ASSEMBLY DIAGRAM	13-34
13.7	PRINTER FRAME ASSEMBLY DIAGRAM	13-35
13.8	TRAY PRESS ASSEMBLY DIAGRAM	13-36
13.9	UPPER COVER ASSEMBLY DIAGRAM	13-37
13.10	LOWER COVER ASSEMBLY DIAGRAM.....	13-38
13.11	POWER SUPPLY ASSEMBLY DIAGRAM	13-39
13.12	MAIN BODY ASSEMBLY DIAGRAM	13-40
13.13	CONTROL ASSEMBLY DIAGRAM	13-41
13.14	FIXED APPLICATOR ASSEMBLY DIAGRAM.....	13-42

13.1 RECOMMENDED INDENTORY PARTS LIST

No.	Unit Name	Part Code	Description	Unit Price C&F J yen by Sea	Qty in Unit	For Rice Lake	For Dealer	Remarks
1	Lift drive	072-2279-26	SENSOR AS		1	1	0	
3	Switching lift	010-4166-09	GEAR HEAD		1	1	0	
4	Switching lift	076-1633-27	MOTOR AS: LIFT CHANGEOVER		1	1	0	
5	Switching lift	091-0795-07	TIMING BELT: XL		1	1	0	
6	Switching lift	12-8583-08	PHOTO INTERRUPTOR TRANS		3	10	5	
7	Power supply unit	72-2230-06	SWITCH: ROTARY		1	1	0	
8	Power supply unit right	61-1532-01	BREAKER: CIRCUIT		1	1	0	
9	Power supply unit right	61-1533-04	BREAKER: CIRCUIT		1	1	0	
10	Power supply unit	90-0514-00	TRANSFORMER: 3 PH		1	1	0	
11	Power supply unit	50-2258-07	ACCESSORY: BUSH: SKINTOP		1	1	0	
12	Power supply unit	50-2281-03	ACCESSORY: LOCK NUT:		1	1	0	
13	Power supply unit right	043-1988-39	PWB: P-858:B		1	2	1	Full mount, Recommend to stock this board. Location B Right.
17	Power supply unit	076-1843-31	SWITCH AS: SEESAW: HEATER		1	1	0	
18	Power supply unit	101-1948-05	RELAY		1	1	0	(Heater Control AS)
19	Power supply unit	16-8922-06	FILTER: SPARK KILLER: VERT		1	1	0	(Heater Control AS)
20	Power supply unit	90-0839-00	CONTROLLER: THERMO		1	1	1	
21	Power supply unit left	092-2886-34	PWB: P-857:A		1	2	1	ROM Size 512
22	Power supply unit left	040-6703-59	PWB: P-858:B		1	2	1	Location A Left
23	Power supply unit left	043-1554-63	PWB: P-858:B		1	2	1	Location C Left, Printed #2
24	Power supply unit left	040-6782-08	Power supply unit: SWITCHING		1	2	1	
25	Power supply unit left	59-8058-06	CONTROLLER: MOTOR		1	1	1	
26	Power supply unit left	40-6902-17	BUZZER AS		1	1	0	
27	Power supply unit rear	092-2515-05	CONTROLLER: MOTOR: AC SERVO		1	2	1	
28	Power supply unit rear	092-2516-09	MOTOR: AC SERVO		1	2	1	
30	Power supply unit safety unit	069-2402-01	ELECTROMAGNETIC CONTACTOR		1	1	0	(Safety unit)
31	Power supply	069-2404-09	ELECTROMAGNETIC		1	1	0	(Safety unit)

No.	Unit Name	Part Code	Description	Unit Price C&F J yen by Sea	Qty in Unit	For Rice Lake	For Dealer	Remarks
	unit safety unit		CONTACTOR					
32	Power supply unit safety unit	072-2108-04	ELECTROMAGNETIC CONTACTOR		1	1	0	(Safety unit)
34	Power supply unit safety unit	17-5673-05	THERMAL RELAY		1	1	0	(Safety unit)
35	Power supply unit safety unit	40-2724-07	FUSE HOLDER: TERMINAL TYPE		19	1	0	(Safety unit)
36	Power supply unit safety unit	00-4119-04	FUSE HOLDER: TERMINAL TYPE		2	1	0	(Safety unit)
37	Power supply unit safety unit	09-5958-01	FUSE: GLASS TUBE		3	3	1	(Safety unit)
38	Power supply unit safety unit	017-5713-01	FUSE: GLASS TUBE		4	4	1	
40	Power supply unit safety unit	09-5960-00	FUSE: GLASS TUBE		6	6	1	(Safety unit)
41	Power supply unit safety unit	70-1052-01	FUSE: GLASS TUBE		8	8	1	(Safety unit)
42	Power supply unit safety unit	101-1948-05	RELAY		1			Common for #18
43	Power supply unit Rear	72-2080-04	SWITCH: SAFETY		8	2	1	(Switch AS safety)
44	Power supply unit	072-5960-02	SWITCH: ACTUATOR: type L		1	1	1	
	Cover under	106-6598-19	SWITCH: ACTUATOR		2	2	2	
	Cover under	106-6599-12	SWITCH: ACTUATOR		2	2	2	
	Cover under	108-0359-09	SWITCH: ACTUATOR		2	2	2	
45	Cover under	108-0360-03	SWITCH: ACTUATOR		1	1	1	
	Feeder move	090-0630-09	MOTOR AS: FEEDER SHIFT		1	1	0	
	Feeder move	072-2099-04	PHOTO INTERRUPTOR: flood		3	3	3	
	Feeder move	072-2100-05	PHOTO INTERRUPTOR		3	3	3	
48	Feeder move	095-4038-04	Sheet Sensor		3	3	3	
48	Feeder move	093-3125-07	TIMING BELT: S5M		2	1	0	
49	Feeder move	12-8583-08	PHOTO INTERRUPTOR: TRANS		3			Common for #2
50	Feeder move	12-4861-09	GEAR HEAD		1	1	0	
53	Feeder drive	033-3078-01	TIMING BELT: S5M		1	1	0	
54	Feeder drive	100-9145-03	TIMING BELT: S5M		1	2	1	
55	Feeder drive	90-0631-02	MOTOR AS: FEEDER		1	1	0	
56	Feeder drive	054-2355-04	TIMING BELT: S5M		2	1	0	
57	Feeder drive	12-8583-08	PHOTO INTERRUPTOR: TRANS		1			Common for #2
58	Film feeder	48-3560-05	SENSOR AS:		1	1	0	Rear left side
59	Film feeder	48-3559-01	SENSOR AS:		1	1	0	Rear right
60	Film feeder	091-0573-07	SOLENOID AS: Grip		4	2	0	
61	Film feeder	45-3604-12	SOLENOID AS: 60W		4	2	0	
62	Film feeder	76-1501-01	TIMING BELT: DT5: P1.5		2	4	2	
63	Film feeder	45-3585-06	TIMING BELT: S5M		2	2	0	
64	Film feeder	76-1551-07	FLAT BELT: ENDLESS		2	4	2	
65	Film feeder	43-1997-14	FAN AS		4	1	0	
	Film feeder	103-3951-09	Herness Relay		1	1	0	
	Film feeder	103-3950-05	Herness Relay		1	1	0	
	Film feeder	103-3817-21	Herness		1	2	0	

No.	Unit Name	Part Code	Description	Unit Price C&F J yen by Sea	Qty in Unit	For Rice Lake	For Dealer	Remarks
	Film feeder	103-3952-11	Herness		1	2	0	
	Film feeder	103-3953-24	Herness		1	2	0	
	Film feeder	103-3954-19	Herness		1	2	0	
66	Film feeder	108-0435-09	FILM FEEDER UNIT		1	1	1	
67	Wrapping unit	45-3628-02	GEAR HEAD		1	1	0	
68	Wrapping unit	25-1669-00	GEAR HEAD		1	1	0	
69	Wrapping unit	48-3558-07	SENSOR AS		1	1	0	Front left side
70	Wrapping unit	43-1671-20	SENSOR AS		1	1	0	Front right side
71	Wrapping unit	45-4372-03	TIMING BELT: S5M		2	1	0	
72	Wrapping unit	45-3583-09	TIMING BELT: S5M		1	1	0	
73	Wrapping unit	12-8583-08	PHOTO INTERRUPTOR: TRANS		6			Common for #2
74	Wrapping unit	90-0629-04	MOTOR AS: L/R WRAPPING		1	1	0	
75	Wrapping unit	90-0628-01	MOTOR AS: F/R WRAPPING		1	1	0	
76	Wrapping unit	90-0840-04	MOTOR: SPEED CONTROLLER UNIT		1	1	1	
77	Heater unit (S)	90-0813-12	HEATER AS:		1	1	0	
78	Cutter unit	108-0221-09	CUTTER: SAW BLADE: KO		2	1	0	
79	Cutter unit	58-8215-16	CLUTCH AS		2	1	1	
80	Cutter unit	58-8216-10	CLUTCH AS		2	1	1	
81	Cutter unit	45-3587-03	TIMING BELT: S5M		4	1	0	
82	Cutter unit	58-8218-17	BRAKE AS		1	1	1	
83	Cutter unit	58-8219-11	BRAKE AS		1	1	1	
84	Cutter unit	90-0806-07	BRAKE AS		1	1	1	
85	Cutter unit	90-0805-03	BRAKE AS		1	1	1	
86	Cutter unit	094-2868-04	ROLLER: THRUST		2	1	1	
87	Cutter unit	76-1590-02	TIMING BELT: AT5		1	1	0	
88	Cutter unit	41-4277-12	TIMING BELT: AT5		1	1	0	
89	Cutter unit	12-8583-08	PHOTO INTERRUPTOR: TRANS		2			Common for #2
90	Set roller unit	53-1937-01	FLAT BELT: ENDLESS		4	2	0	
91	Set roller unit	39-4233-09	ROUND BELT: SEAMLESS		2	1	0	
92	Set roller unit	108-0189-11	MOTOR AS: 4.5W		2	1	0	
93	Set roller unit	108-0190-16	MOTOR AS: 7.2W		2	1	0	
94	Set roller unit	41-4287-10	GEAR HEAD		2	1	0	
95	Set roller unit	108-0188-09	SENSOR AS		2	1	0	
96	Set roller unit	12-8583-08	PHOTO INTERRUPTOR: TRANS		8			Common for #2
97	Film setting roll	001-0102-04	STOPPER		4	8	4	
98	Lift head unit	90-2433-09	LIFT HEAD UNIT		1	1	1	
99	In-feed conveyer	43-1681-27	SENSOR AS		1	1	0	
100	In-feed conveyer	59-8057-02	MOTOR AS: STEPPING		1	1	0	
101	Tray press	49-2456-04	RINK AS		2	1	0	
	Applicator fixed part	069-2405-02	Power supply unit: SWITCHING		1	1	1	

No.	Unit Name	Part Code	Description	Unit Price C&F J yen by Sea	Qty in Unit	For Rice Lake	For Dealer	Remarks
	Applicator fixed part	093-1702-27	PWB'P-916'C		1	1	1	
	Applicator fixed part	090-5391-07	FAN AS		1	1	1	
	Applicator move part	103-3787-13	Cushion		1	2	1	
	Applicator move part	070-5204-14	PHOTO INTERRUPTOR: TRANS		11	11	5	
	Applicator move part	094-0414-28	FAN AS		1	1	0	
	Applicator move part	079-3002-08	MOTOR AS STEPPING		1	1	0	
	Applicator move part	079-3003-11	MOTOR AS: STEPPING		1	1	0	
	Applicator move part	077-0000-14	MOTOR AS: STEPPING		1	1	0	
	Applicator move part	079-3001-04	MOTOR AS: STEPPING		1	1	0	
	Applicator move part	108-8031-07	Applicator move part		1	1	0	
	Applicator move part	079-1443-28	Herness		1	2	1	
105	Maintenance part	76-9928-06	BRUSH: ANT-STATIC		3	10	5	
106	Scale	047-3068-01	LC UNIT: CLC-25N		1	2	1	
107	Scale	070-3480-73	PWB'P-930'A-1		1	2	1	
	Key unit	108-8036-05	Key unit		1	1	0	
109	Display unit	108-8035-01	DISPLAY: LCD		1	1	1	
110	Printer	094-0086-01	PRINTER: THERMAL		1	5	1	
	Printer	064-5587-01	PHOTO INTERRUPTOR		1	1	0	
111	Printer	066-4500-09	PHOTO INTERRUPTOR		1	1	0	
112	Printer	098-8087-12	SENSOR AS: HEAD		1	1	0	
113	Printer	098-8086-00	SENSOR UNIT: NON STOP		1	1	0	
114	Printer	092-8406-04	MOTOR AS: STEPPING		1	1	0	
115	Printer	068-9930-19	PWB'P-925'-1		1	2	1	
	Printer	072-5467-21	MOTOR AS: roll		1	1	0	
118	Main control unit	097-5687-37	PWB'P-910'H-2		1	2	1	
	Main control unit	101-7737-08	PWB'P-909'D-3		1	2	1	
	Main control unit	069-6884-17	PWB'P-918'A-1		1	2	1	
	Main control unit	101-1508-00	PWB'P-919'B-3		1	2	1	
	Main control unit	106-1434-04	Power supply unit: SWITCHING		1	2	0	
	Main control unit	095-4469-06	PWB'P-967'-1		1	2	1	
127	Film brake unit	12-3206-05	CLUTCH:ONE WAY		2	2	1	
128	Film brake unit	76-1632-23	MOTOR SA: ROLL RETAINER		2	1	0	
129	Film brake unit	45-3603-19	SOLENOID AS: 38W		2			Common for #61
130	Film brake unit	76-1686-24	BALT: LEATHER		2	1	0	

No.	Unit Name	Part Code	Description	Unit Price C&F J yen by Sea	Qty in Unit	For Rice Lake	For Dealer	Remarks
132	Film brake unit	030-2864-06	TIMING BELT: S5M		2	1	0	
133	Pusher CV unit (ST)	92-2669-05	FLAT BELT: FINGER JOINT		1	1	0	
134	Pusher CV unit (ST)	108-0489-00	MOTOR AS: PUSHER CV		1	1	0	
135	Heater CV unit (ST)	92-2688-06	FLAT BELT: HEATPROOF		1	1	0	
136	Heater CV unit (ST)	90-0813-12	HEATER AS		1			Common for #78
137	Heater CV unit (ST)	108-0490-04	MOTOR AS: HEATER CV		1	1	0	

13.2 PREVENTIVE MAINTENANCE PARTS LIST

Consumption Parts and Periodical Replacement Parts List

No.	Part name	Part Number	Obtaining method
1	Label		Dealer
2	Film		Dealer
3	Thermal printer	094-0086-01	Factory

Recommended Parts for Periodic Maintenance

No.	Part Name	Check Item	Number in Exploded Drawing	Recommended Period	Remarks	Required Parts	Tools/ Test program/ Oil
1-1	Lift head unit	(1) Loose screws: Tighten the screws.		1 year			
		(2) Surface wear-out and damage of the supporter head	120·130·140·190·200	0.5 year	Replace the head when remarkably worn out. Recommended replacement in 2.5 years	Supporter head	
		(3) Rust on the lift head spring: Restore the spring.	60·70·160	0.5 year	Or, fix the lift head so that it does not jolt.	Spring coil tension	
		(4) Retentivity of the ball plunger	110	0.5 year		Ball plunger	
		(5) Oil run out at the lift changeover driven part: Detach the lift head and wipe it with the cleaning brush cotton waste, etc.		0.5 year	Lubricate the part when oil runs out.	Lift head frame	Grease white alcom No2
		Whole	Every day			Grease white alcom No2	

No.	Part Name	Check Item	Number in Exploded Drawing	Recommended Period	Remarks	Required Parts	Tools/ Test program/ Oil
1-2	Wrapping unit	(1) Loose screws: Tighten the screws.		0.5 year	Test mode operation		
		(2) Luster of the insert plate and the roller: Use sand paper to remove the luster.	290•310•860•870	0.5 year	Grind with sand paper of about # 100.		
		(3) Wear-out of the roller bracket bush	300•100	1 year	Recommended replacement in 2 years.		
		(4) Front/rear drawer is balanced with the discharge roller.	290•920	0.5 year	Replace the part when remarkably worn out. Replace the part when jolting.		
		(5) Run out of oil at the stay: Apply grease.	20	1 year	Lubricate the part when oil runs out.		Grease NITIMORI L-210
		(6) Run out of oil at the shaft: Apply grease.	40•360	1 year	Lubricate the part when oil runs out.		Grease Shell Albanian grease
		(7) Cleaning of the photo sensor	530	1 year			Air release
		(8) Tension of the right/left timing belt	220	1 year			
		(9) The pusher plate must not hit the limit stopper when it stops.	260	0.5 year	Adjust the detection board when intensely hit.		
		(10) Cleaning of the rear side of the pusher plate: Remove the stuck label.	260	Every day			
		(11) Tension and damage of the side drawer timing belt	450	0.5 year	Replace the belt when no more tensible.		

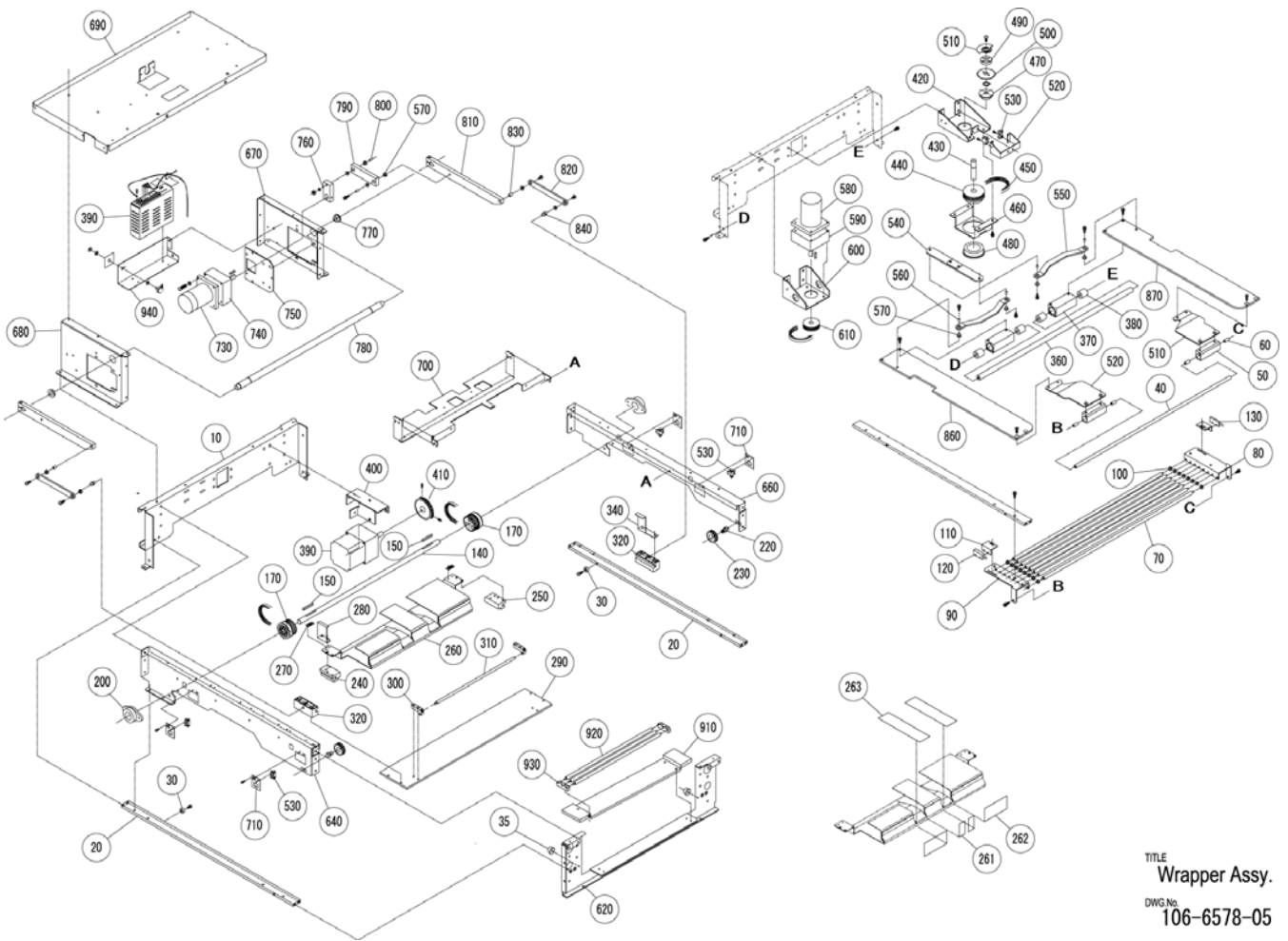

TITLE
Wrapper Assy.
DWG.No.
106-6578-05

No.	Part Name	Check Item	Number in Exploded Drawing	Recommended Period	Remarks	Required Parts	Tools/ Test program/ Oil
1-3	Infeed unit Feeder move unit	(1) Loose screws: Tighten the screws.		0.5 year	Test mode operation		
		(2) Crack of the chain	140·180	0.5 year			
		(3) Run out of oil at the drawer rail (inside cover unit)	12·13	2 years	Lubricate the rail when oil runs out.		Grease Shell Albanian grease
		(4) Cleaning of the infeed tab detection sensor and the and the reflector: Confirm the LED blinking	50	0.3 year	Perform cleaning as frequently as possible.		Air release
		(5) Scale measurement		Every day			
		(6) Space cleaning of the weigh platter and the chain		Every day			
		(7) Cleaning of the foreign material detection sensor (emitter and receiver)	290 (Move unit)				
		(8) Cleaning of the reflector of the commodity detection sensor: Confirm the LED blinking.	160 (Move unit)				

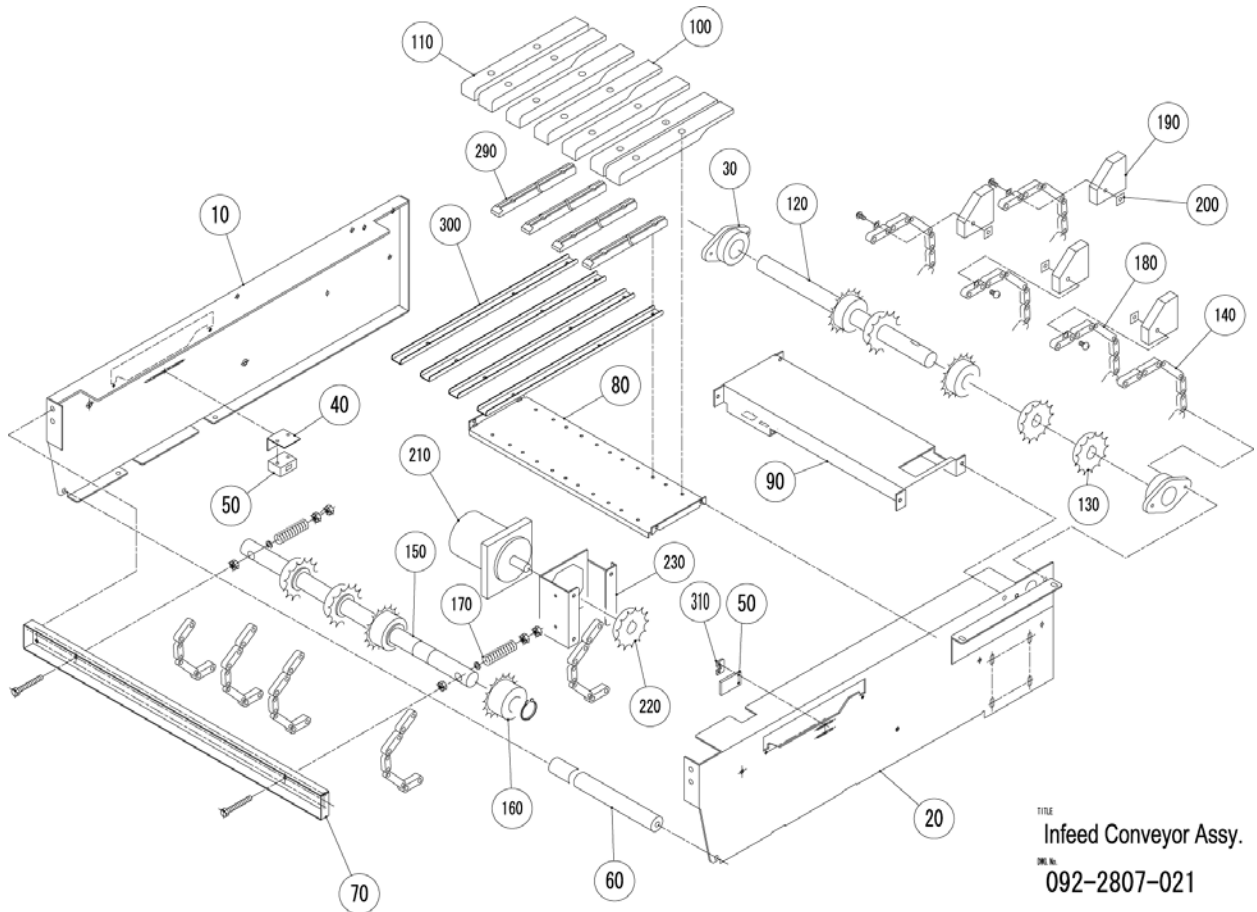

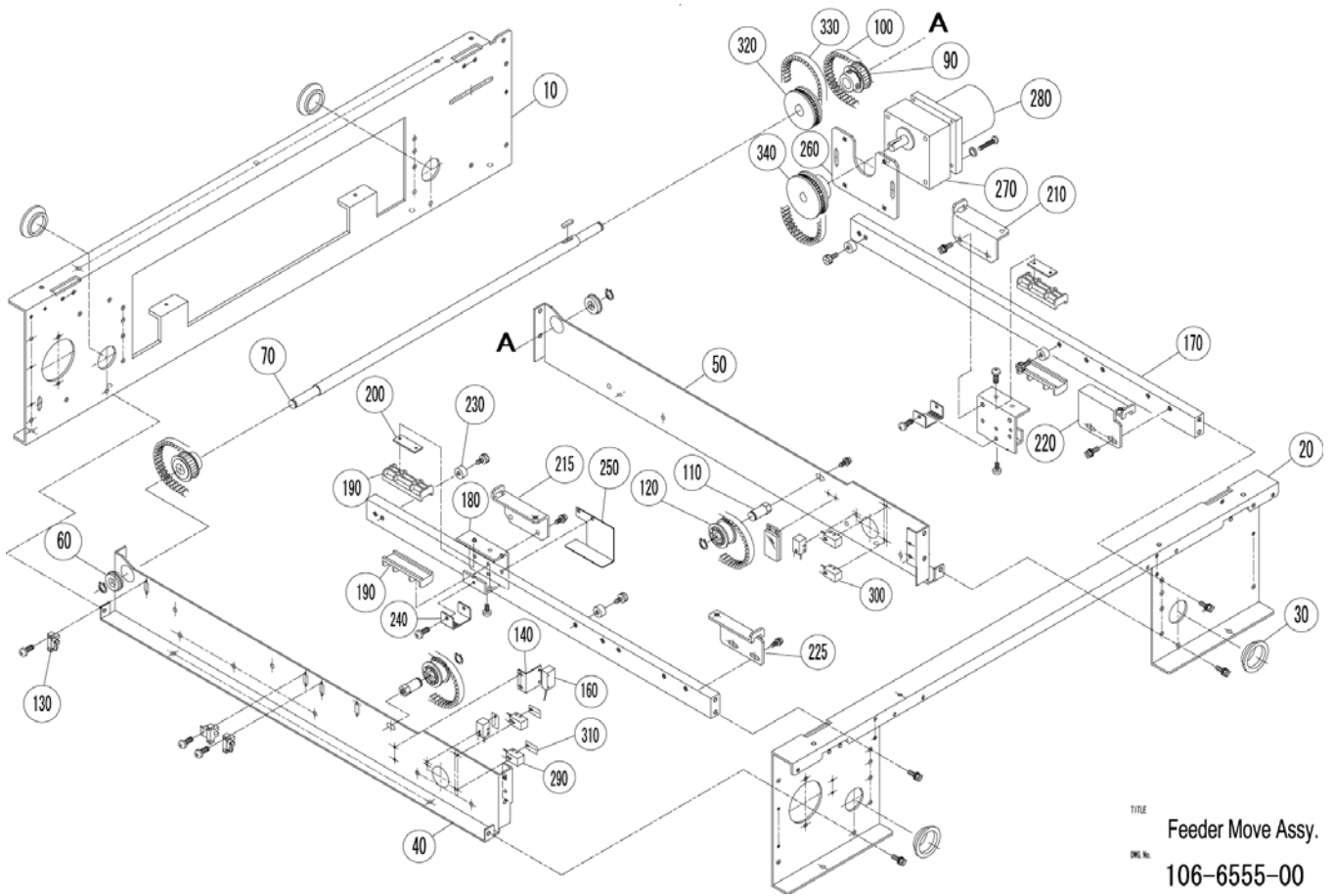

TITLE Feeder Move Assy.
 Dwg. No. 106-6555-00

No.	Part Name	Check Item	Number in Exploded Drawing	Recommended Period	Remarks	Required Parts	Tools/ Test program/ Oil
1-4	Scale unit	(1) Zero span confirmation		1 year			30lb weight, Test modes
		(2) Bias placement check		1 year			30lb weight
		(3) Agreement between the mass display and the printed value. Confirm in the labelling mode.		1 year			
		(4) Level confirmation		1 year			

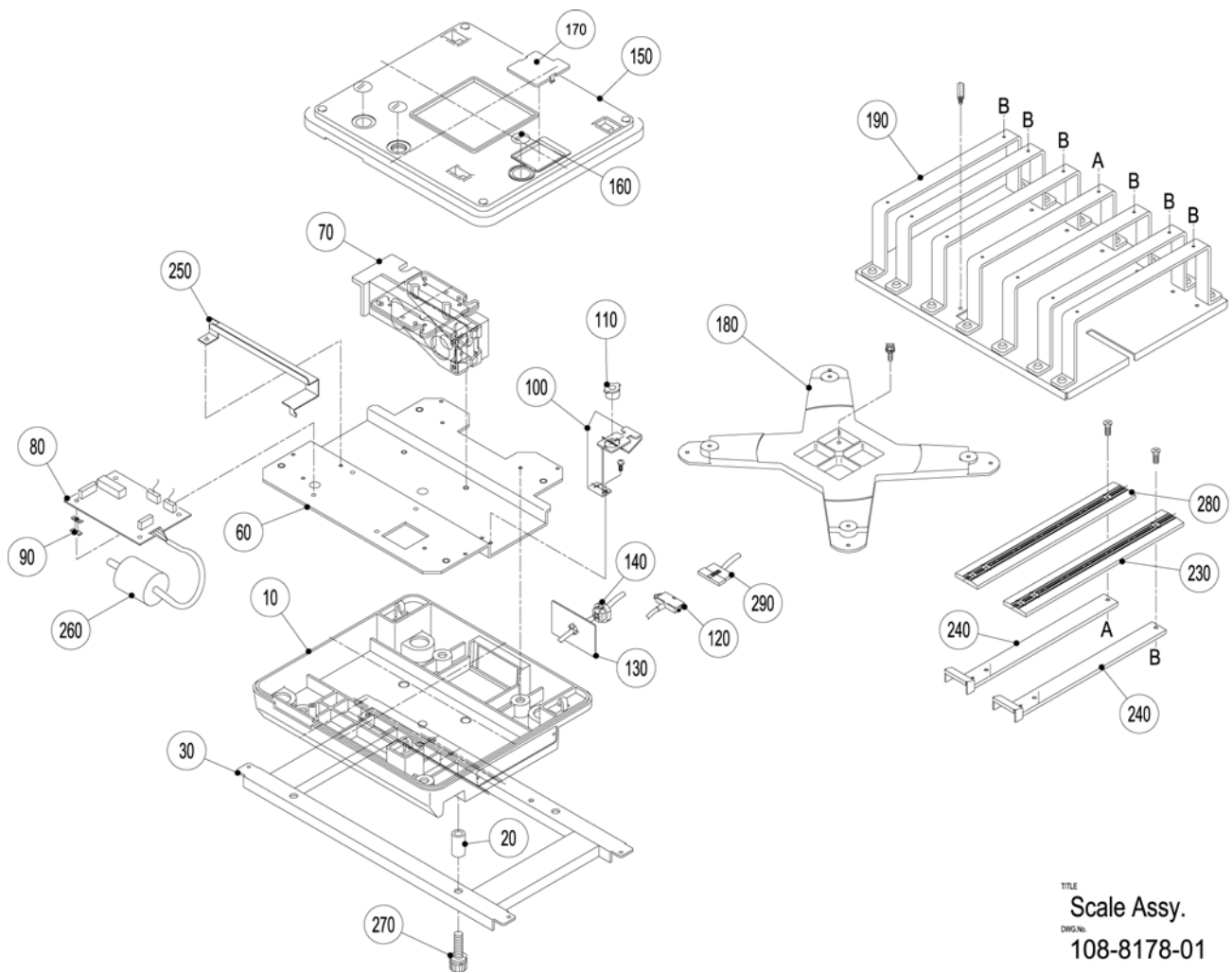

No.	Part Name	Check Item	Number in Exploded Drawing	Recommended Period	Remarks	Required Parts	Tools/ Test program/ Oil
1-5	Film feeder unit	(1) Luster degree, tension, damage of the timing belt (DT5) and the film retentivity	240	1 year	Replace the belt when damaged, expanded, or worn out. Recommended replacement in 2.5 years		
	Feeder drive unit	(2) Tension, damage, and meander of the flat belt endless (green)	650	1 year			
	Cutter unit	(3) Confirmation of tension and meander of the timing belt (375L)	150 (Drive unit)	1 year			
		(4) Check if a film offcut remains around the feeder. Remove the offcut if any.		0.3 year			
		(5) Solenoid operation (releasing and clamping)	340-900	0.5 year			
		(6) Oil run out of the shaft	120 (Drive unit)	0.5 year	Lubricate the shaft when oil runs out.		Grease NITIMORI L-210
		(7) Centering state of the film feeder (right and left)		1 year			
		(8) Tension and damage of the timing belt (AT5)	370-380 (Cutter unit)	1 year			
		(9) Cleaning of the feeder count encoder sensor	170 (Drive unit)	1 year			
		(10) Cleaning of the film detection sensor and the reflection seal. Confirmation of the LED blinking.	760-770	Every day			

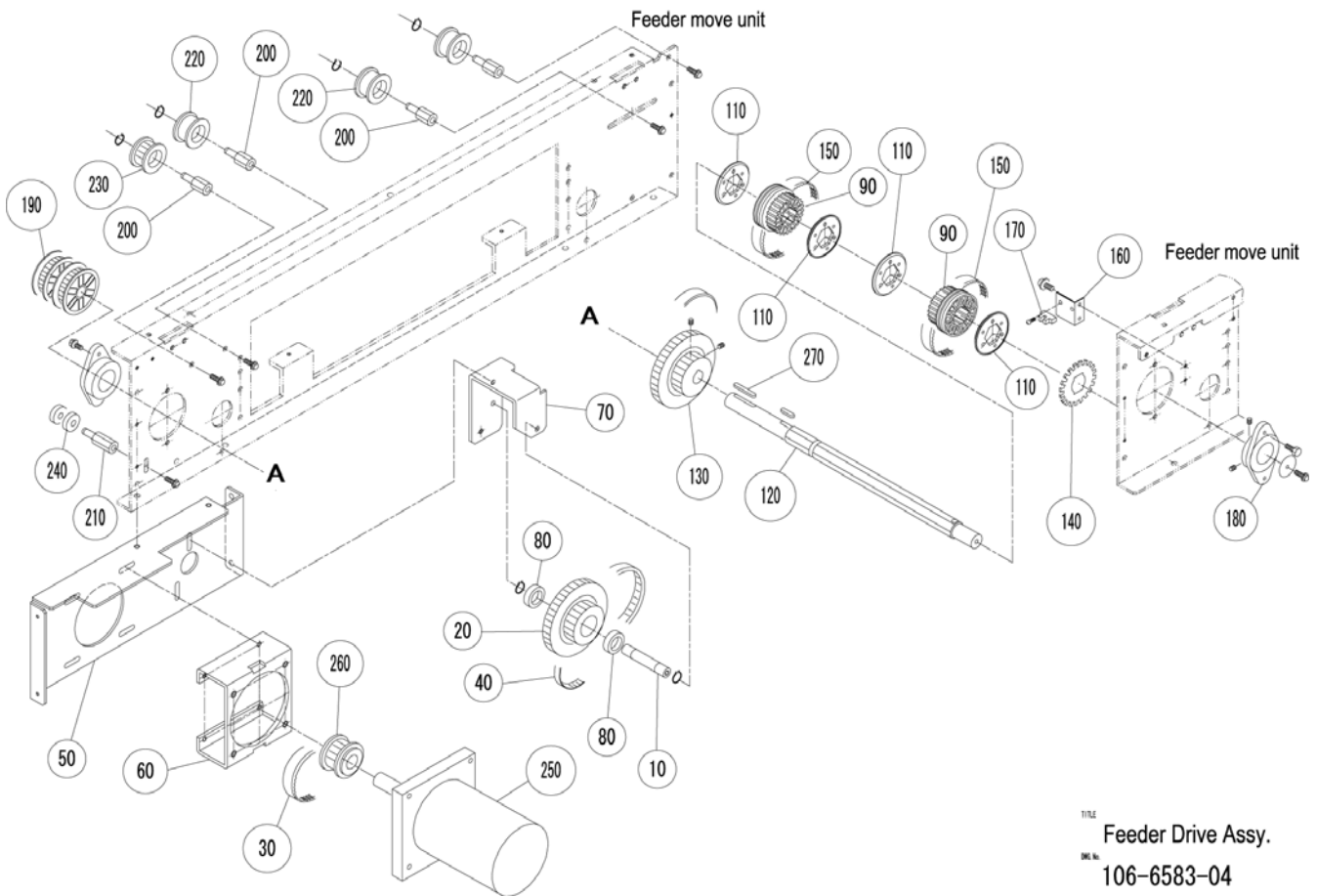

TITLE Feeder Drive Assy.
 DRG. No. 106-6583-04

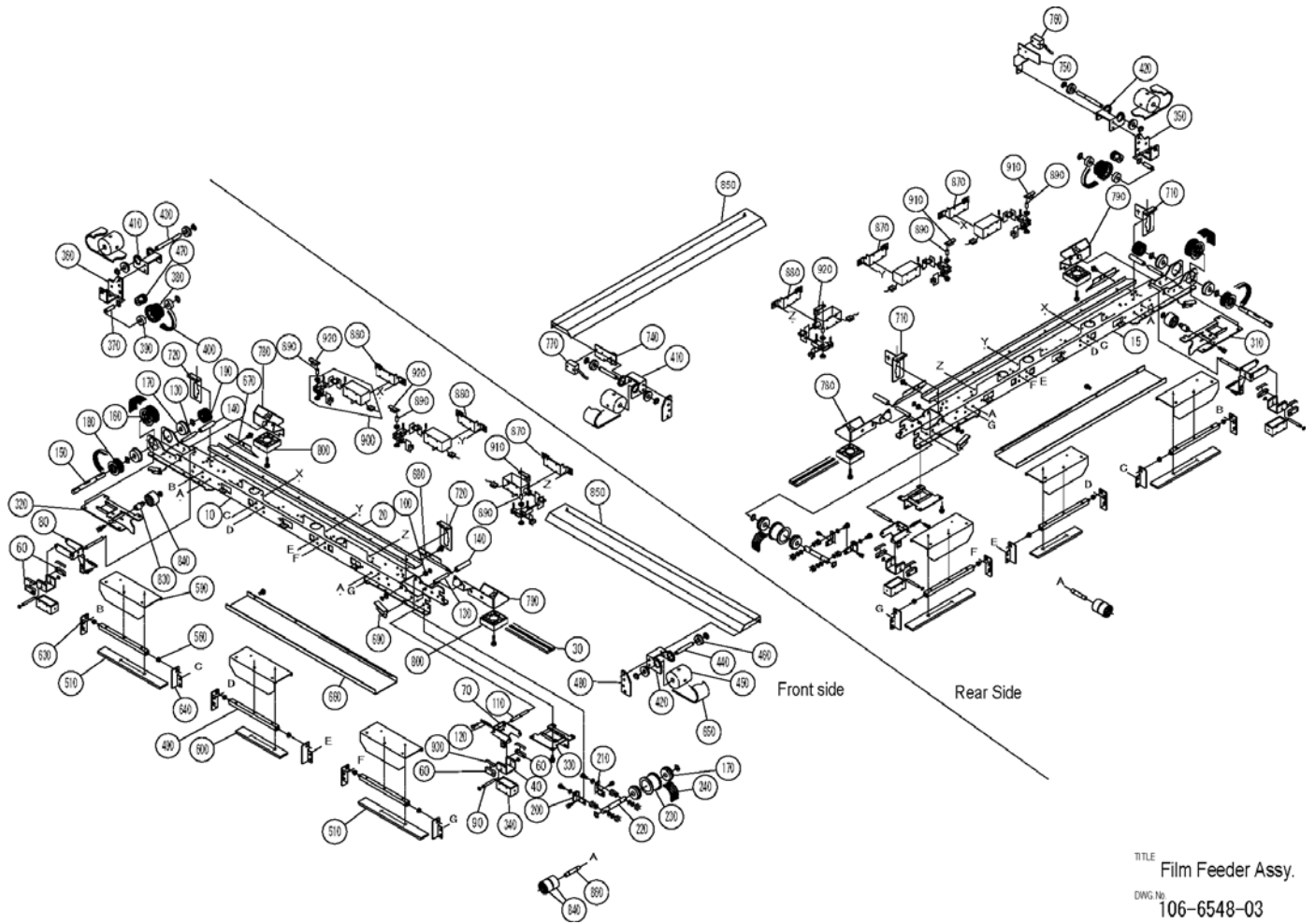

No.	Part Name	Check Item	Number in Exploded Drawing	Recommended Period	Remarks	Required Parts	Tools/ Test program/ Oil
1-6	Cutter unit	(1) DC clutch performance: Film feeding state, Stand-by position	210·220	0.5 year	Replace the clutch when remarkably skidded.		
		(2) DC brake performance: Film feeding state, Stand-by position	170·180· 190·200	0.5 year	Replace the brake when remarkably skidded.		
		(3) Cleaning of the feeder roller	160	0.5 year	Replace the roller when damaged.		
		(4) Securing of upper and lower space size (2mm) for the cutter guide and equability	350·360 (Film press)	0.5 year			
		(5) Rust on the cutter blade		0.5 year			
		(6) Cleaning of the cutter original point photo sensor	340	1 year			Air release

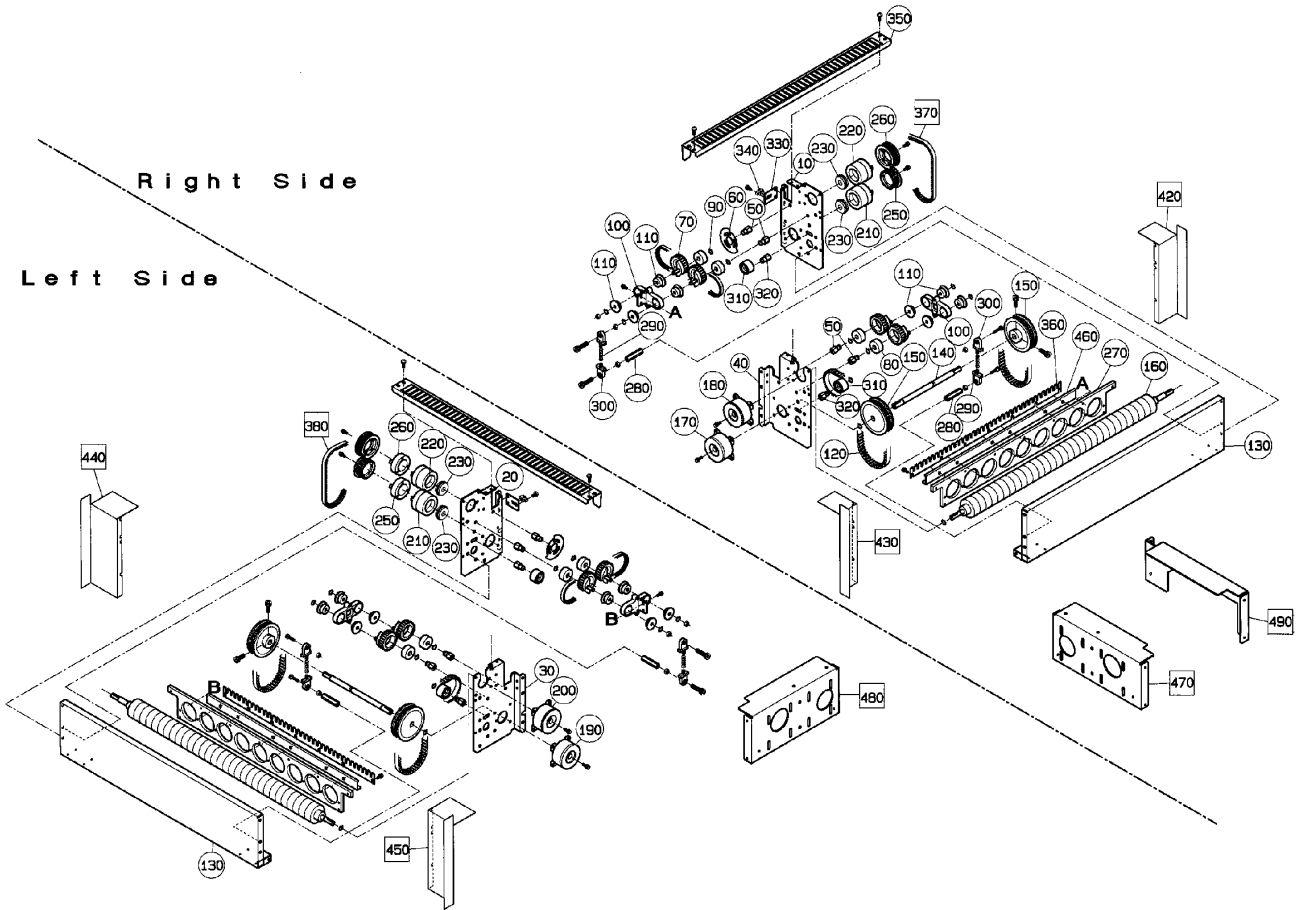

TITLE Cutter Assy.
 DWG.No. 106-6559-04

No.	Part Name	Check Item	Number in Exploded Drawing	Recommended Period	Remarks	Required Parts	Tools/ Test program/ Oil
1-7	Film press unit	(1) Loose screws. Tighten the screws.		1 year			
		(2) Film grip power of the film pinch lever in stand-by state	200·210	0.5 year	Recommended replacement in 2.5 years		
		(3) Tension of the round belt endless	90	0.5 year	Replace the belt when expanded.		
		(4) Cleaning of the film pinch photo sensor: Confirm the LED blinking	280	1 year			
		(5) Position fitting of the film feeder green belt and the film holding green belt	90	0.5 year			
		(6) Cleaning of the film upper and lower photo sensor. Confirmation of the LED blinking.	280	1 year			
		(7) Cleaning of the film width detection sensor and the reflection seal: Confirm the LED blinking.	560	1 year			

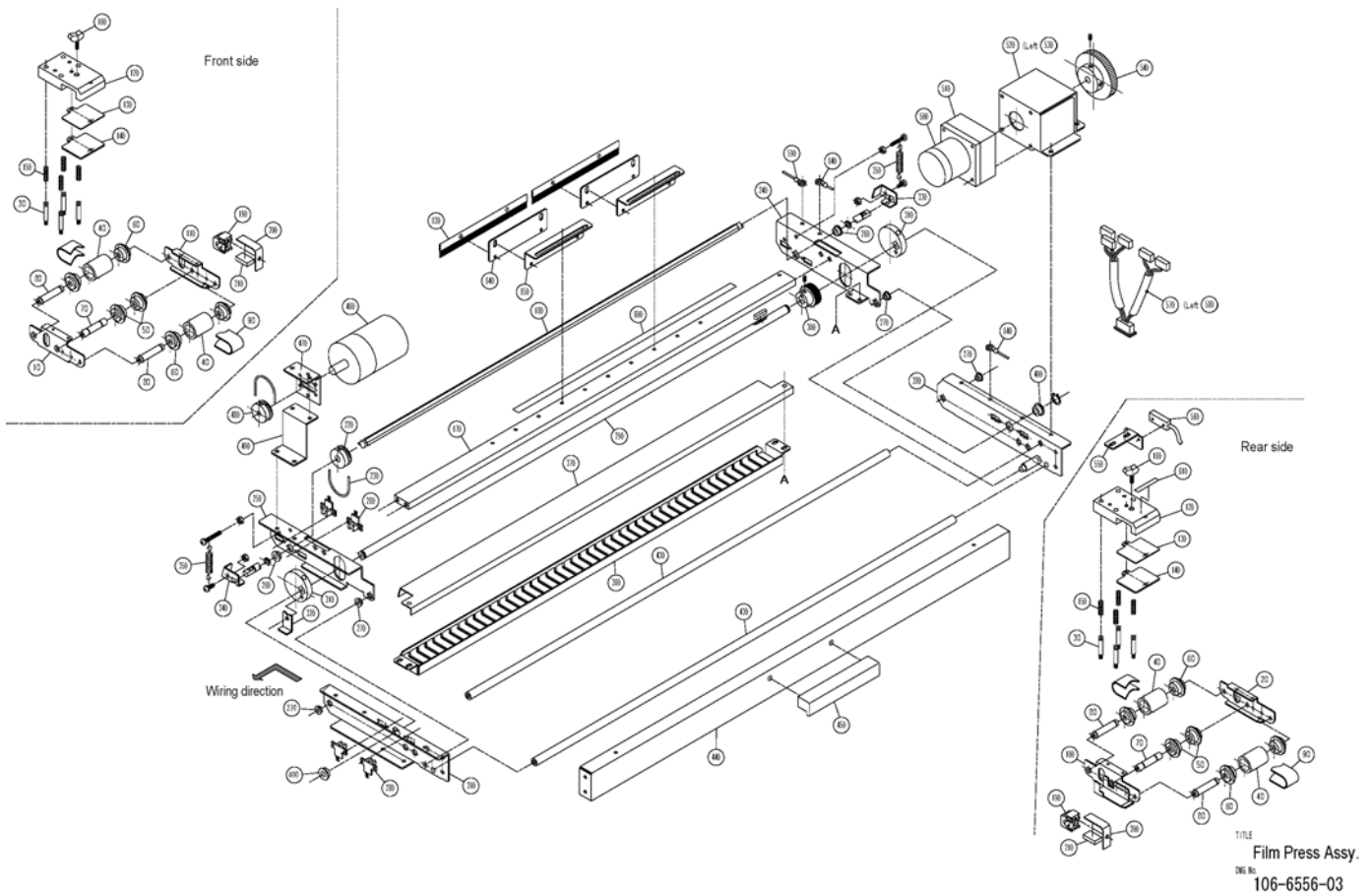

No.	Part Name	Check Item	Number in Exploded Drawing	Recommended Period	Remarks	Required Parts	Tools/ Test program/ Oil
1-8	Lift drive	(1) Cleaning of the lower limit photo sensor: Confirm the LED blinking.	15	0.5 year			
		(2) Oil leakage in the gear box.	3·12	3 years			
		(3) No water splash to the servo controller.	9 (Power supply unit)	0.5 year			
		(4) Abnormal sound when operating.		1 year			Test mode operation

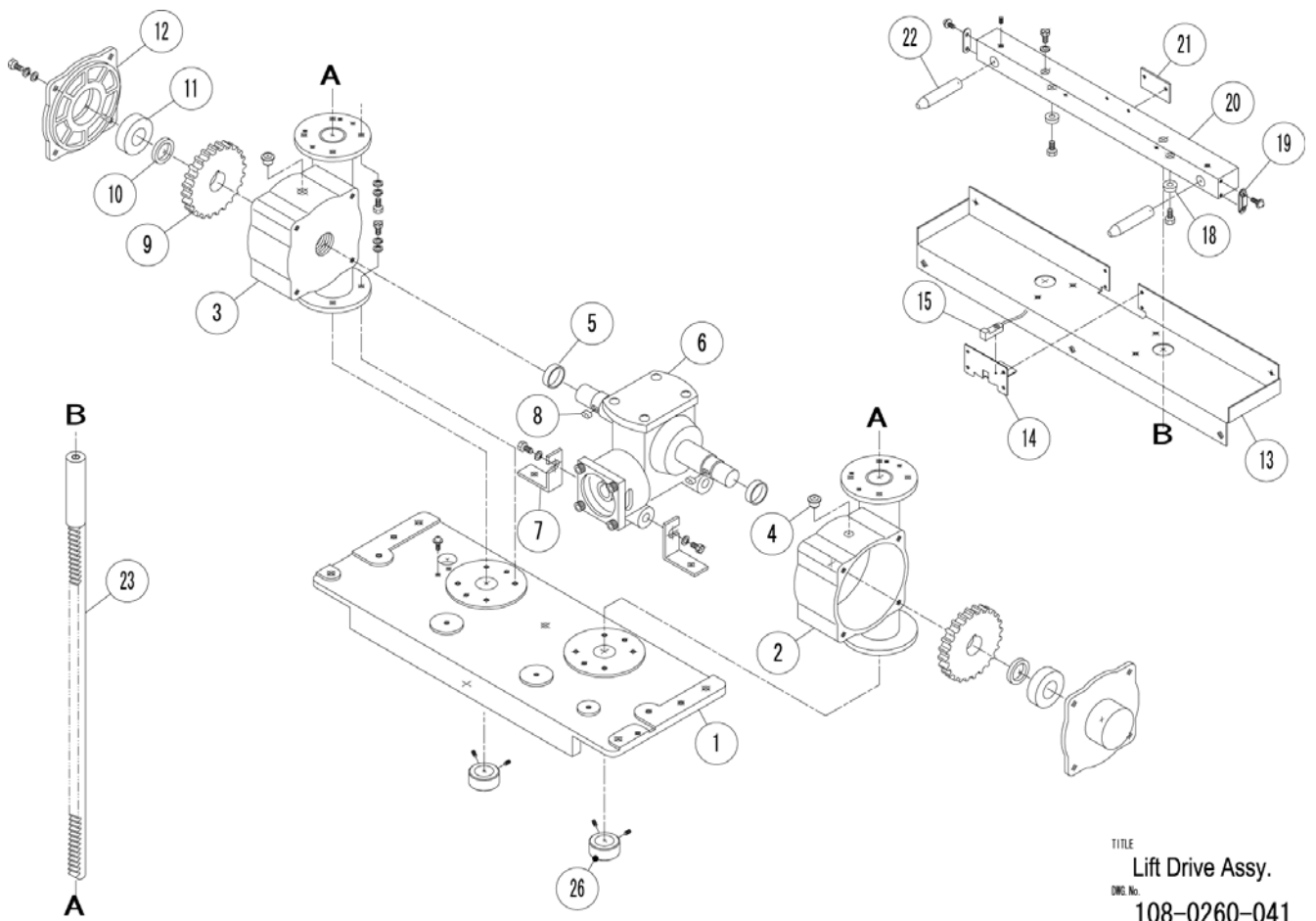

No.	Part Name	Check Item	Number in Exploded Drawing	Recommended Period	Remarks	Required Parts	Tools/ Test program/ Oil
1-9	Lift changeover	(1) Abnormal sound when operating: Confirm large and small lift changeover.		1 year			Test mode operation
		(2) Paralleled.changeover lever.	150	1 year			
		(3) Cleaning of the changeover photo sensor: Confirm the LED lighting.	180	1 year			
		(4) Oil run out of the drive shafts (right and left)	50	1 year	Lubricate the shaft when oil runs out.		

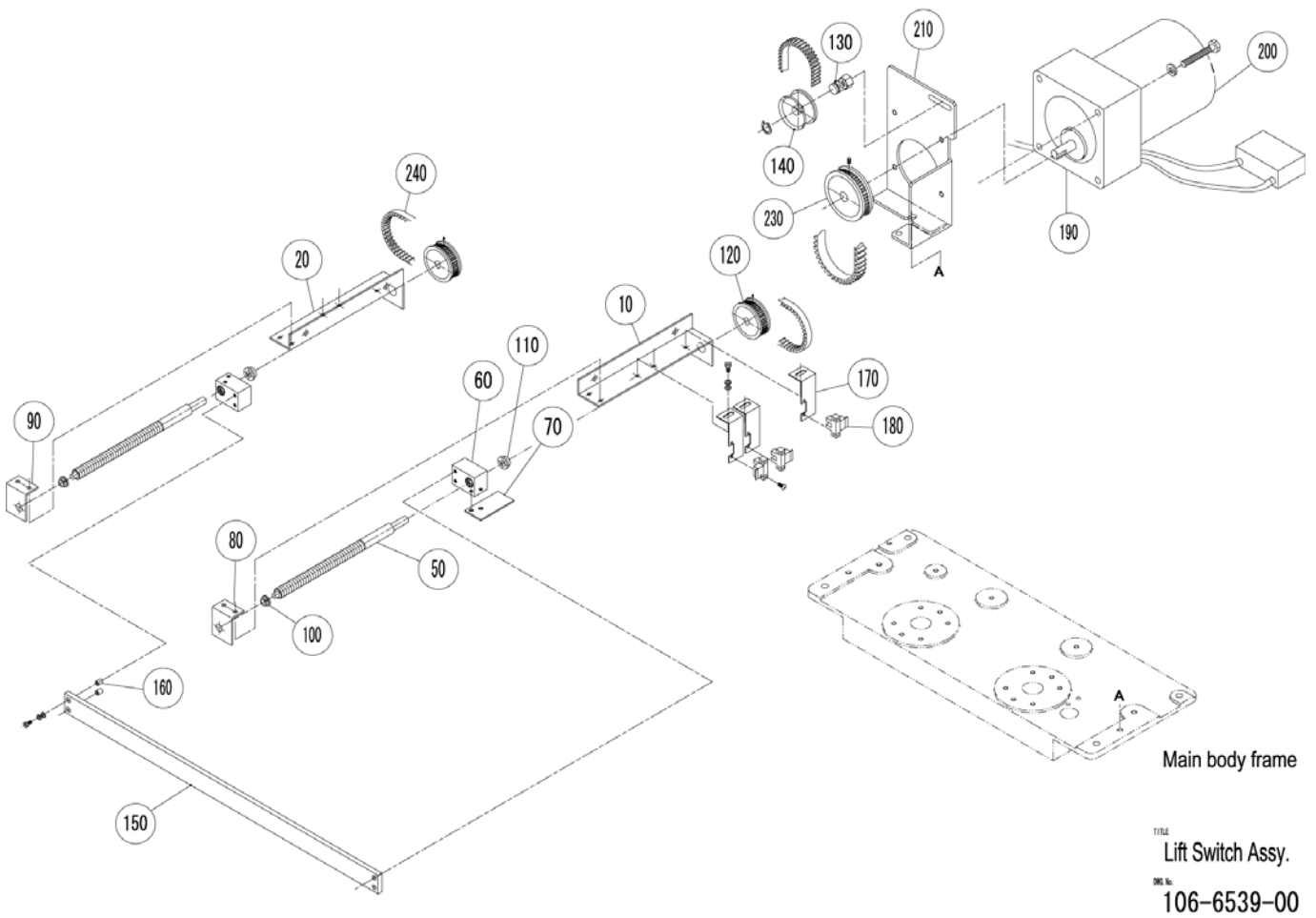

No.	Part Name	Check Item	Number in Exploded Drawing	Recommended Period	Remarks	Required Parts	Tools/ Test program/ Oil
1-10	Roll holder	(1) Clamp lever performance. The paper tube is clipped.		0.5 year			
		(2) Position when the roll is set. of Appropriate film amount is placed on the feeder belt must be secured.		0.5 year			
		(3) Film brake performance: Confirm that the film does not overrun when it stops.		0.5 year	Replace the belt when the leather belt brake cannot be adjusted.		

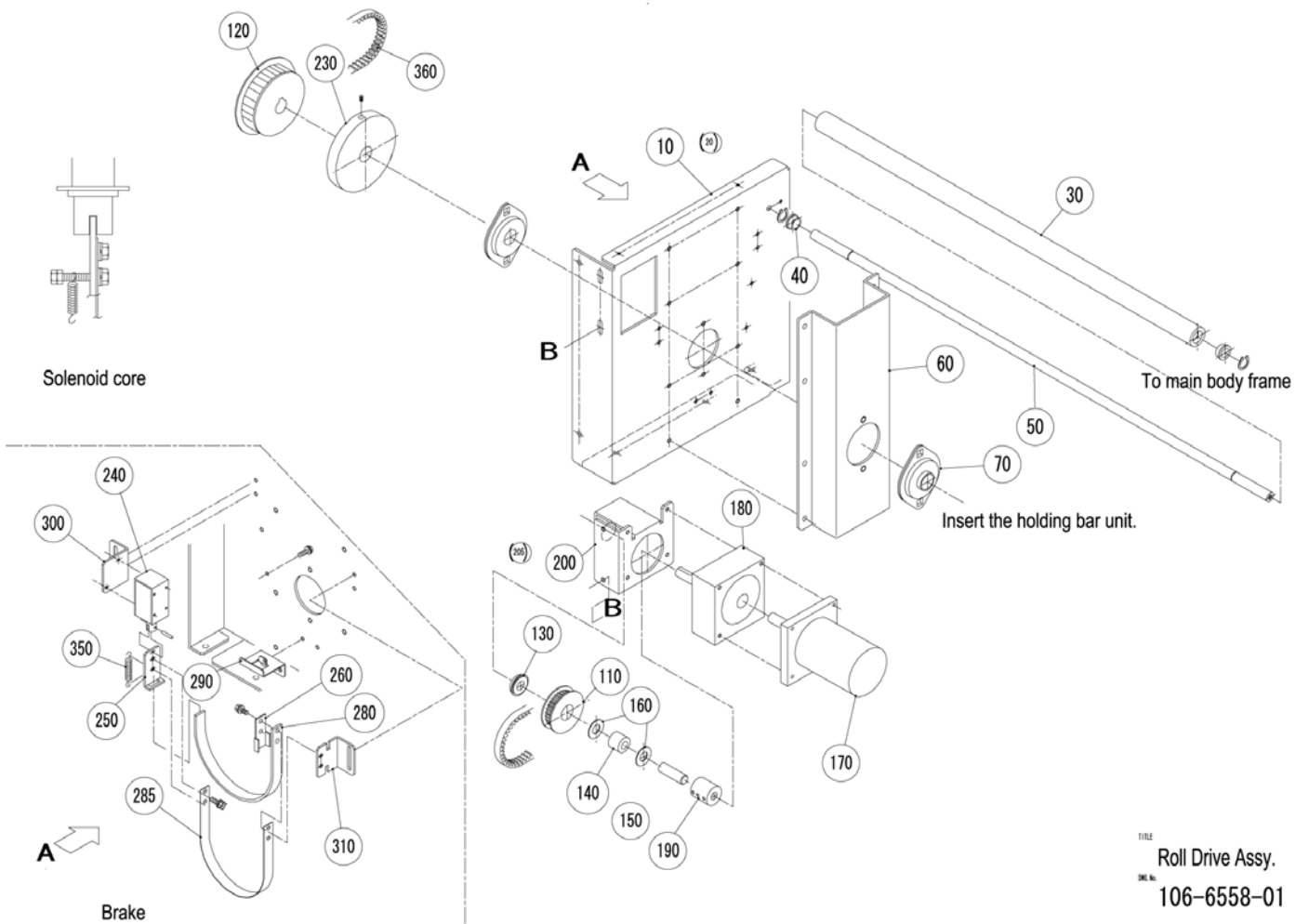

No.	Part Name	Check Item	Number in Exploded Drawing	Recommended Period	Remarks	Required Parts	Tools/ Test program/ Oil
1-11	Feeder move	(1) No abnormal sound when operating		1 year			Test mode operation
		(2) Confirmation of the timing belt (S5M) tension.	100	1 year	Replace the belt when expanded.		
		(3) Oil run out of the stay.	170	1 year			
		(4) Cleaning of 3 photo sensors for move position detection.	130	1 year			

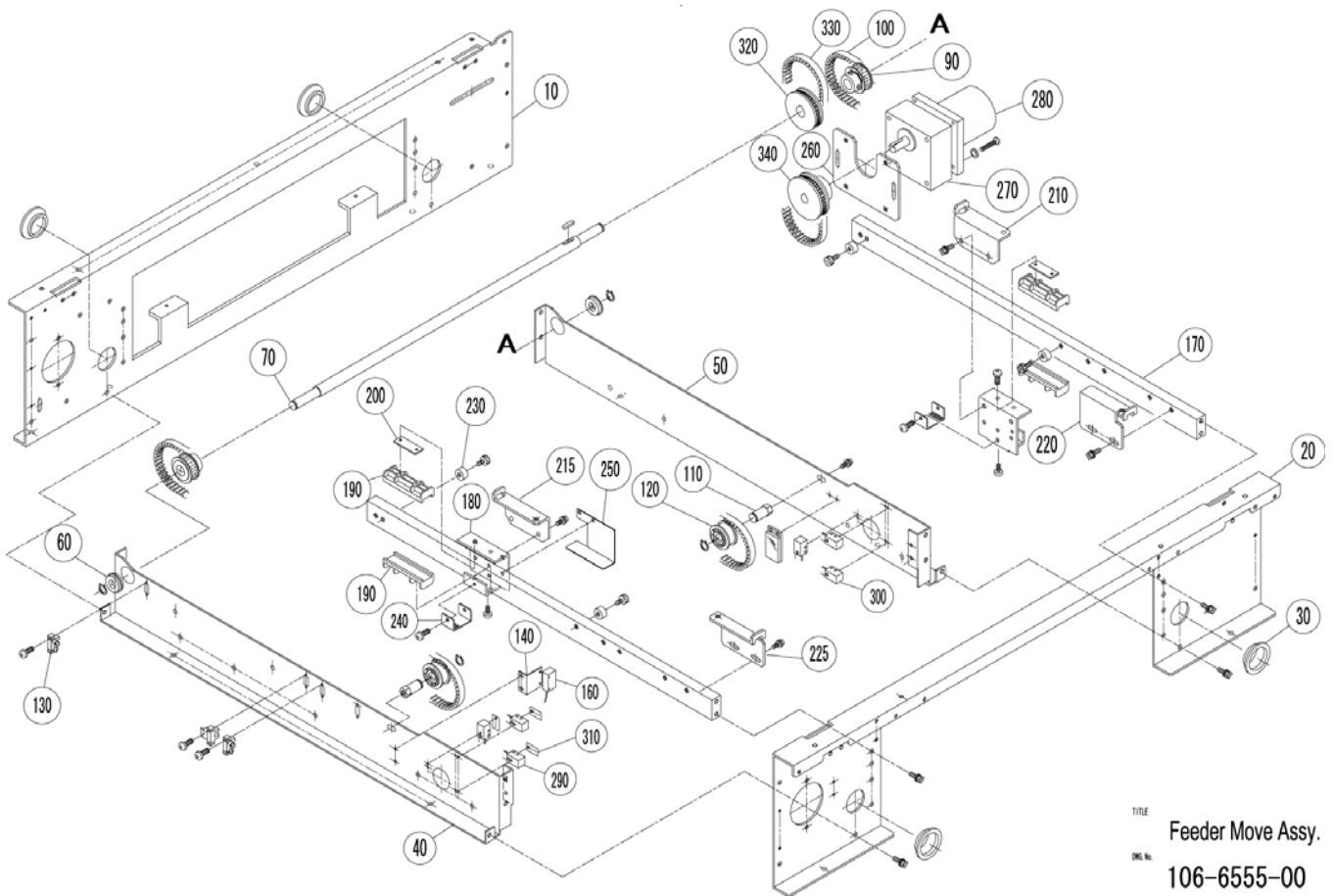

No.	Part Name	Check Item	Number in Exploded Drawing	Recommended Period	Remarks	Required Parts	Tools/ Test program/ Oil
1-12	Applicator unit	(1) Confirmation of up and down, right and left, back and forth, rotation of the arm.		1 year			Test mode operation
		(2) Cleaning of the move photo sensors, right and left (2 pcs.), back and forth (2 pcs.), up and down (2 pcs.), rotation (2 pcs.).	57	1 year			
		(3) Confirmation of the apical end up and down operation.		1 year			
		(4) Confirmation of the label sucking state		0.5 year			
		(5) Wear-out of the sucking sponge	1	0.5 year	Replace the sponge when worn out.	Sucking sponge	
		(6) Cleaning of the label detection sensor (in the sucking sponge).	61	Every day			
		(7) Lubrication to the shafts (right and left (2 pcs.), back and forth (2 pcs.), up and down (1 pc.)).	21·32·38	1 year			Grease Shell Albanian grease

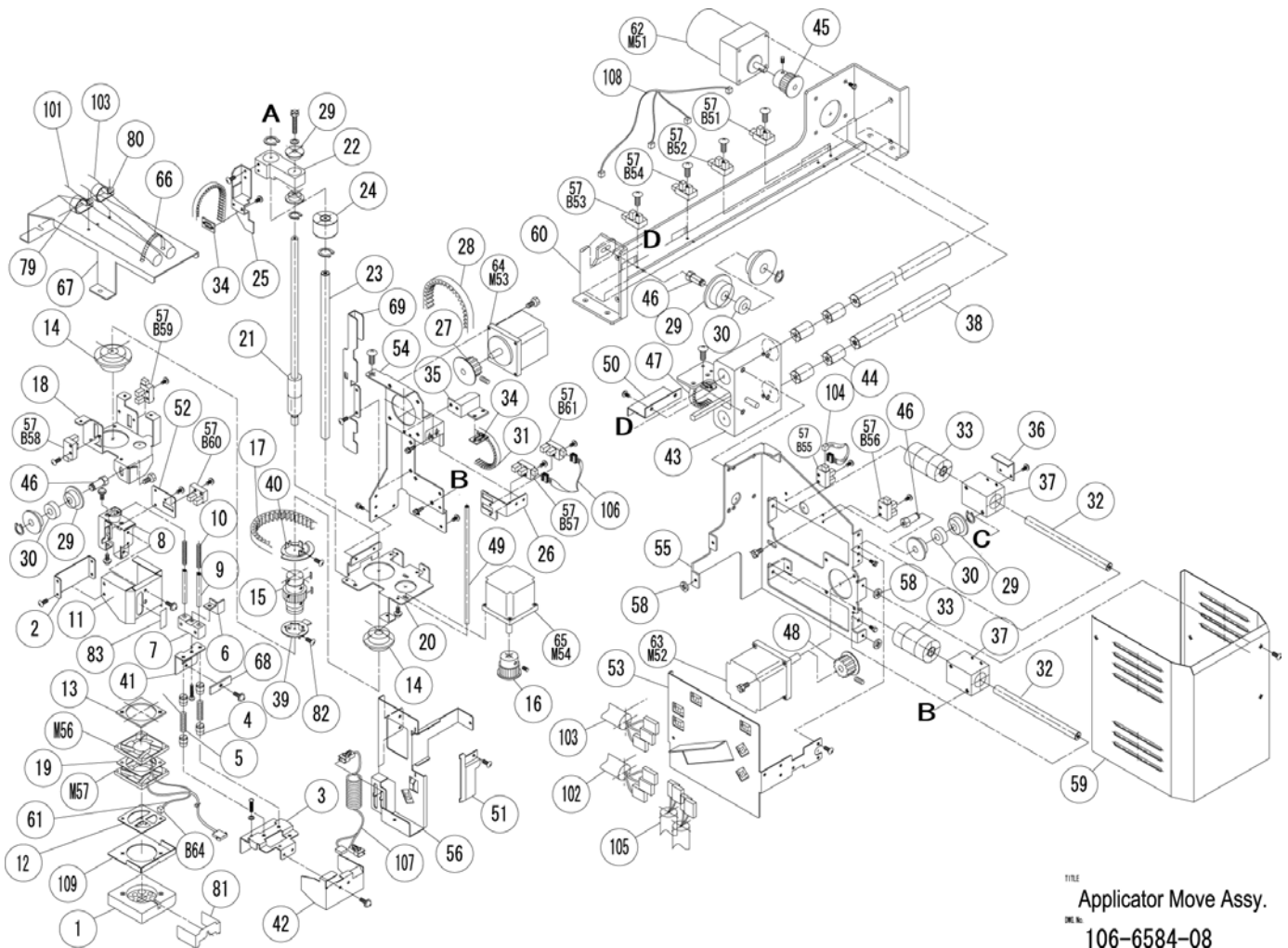

No.	Part Name	Check Item	Number in Exploded Drawing	Recommended Period	Remarks	Required Parts	Tools/ Test program/ Oil
1-13	Printer unit	(1) Confirmation of the print condition, density, and position."		0.5 year			
		(2) Confirmation of abnormal peeling off when the label is fed and the paper is wound.		1 year			
		(3) Confirmation of the head-up sensor ON and OFF.	508	1 year			
		(4) Cleaning of the peel sensor and the label sensor.	507•503•504	0.5 year			
		(5) Cleaning of paste on the label sucking platform. Confirmation of the platform height and the roller rotation.	1•2•4•5•6•100•101	0.5 year			
		(6) Confirmation of the fixed position (gear gap and hitting magnet position) of the printer frame when labels are installed.	38•43	1 year			
		(7) Confirmation of abnormal sound and engagement at the winding drive gear connection.	38•61	1 year	Recommended to replace for 30km-60km.		
		(8) Cleaning of the thermal head.	501	Every day	Recommended to replace in 2 years.		Alcohol
		(9) Cleaning of the print roller.	48	Every day	Replace the part when it is skidded.	Print roller rubber	Alcohol

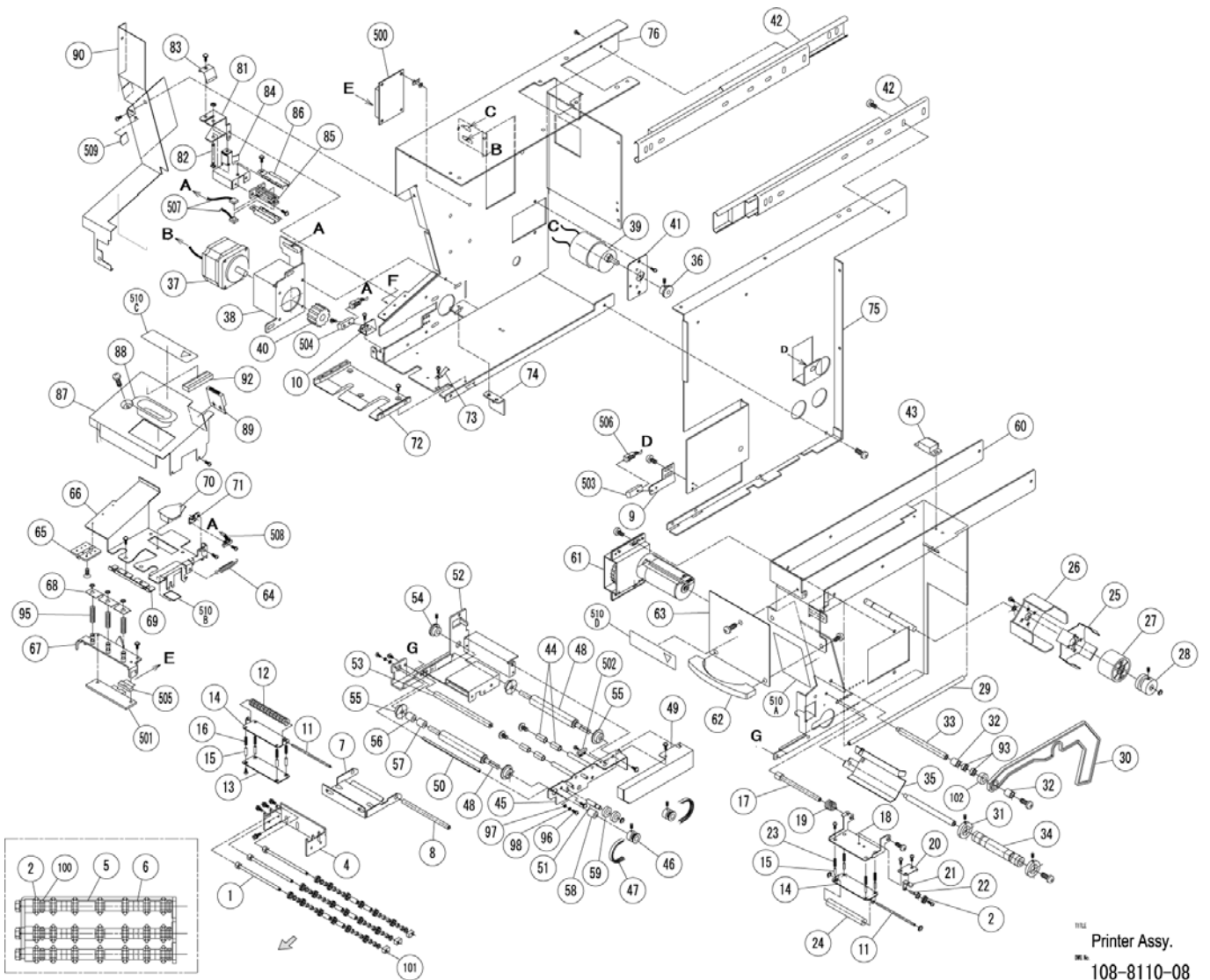

Printer Assy.
108-8110-08

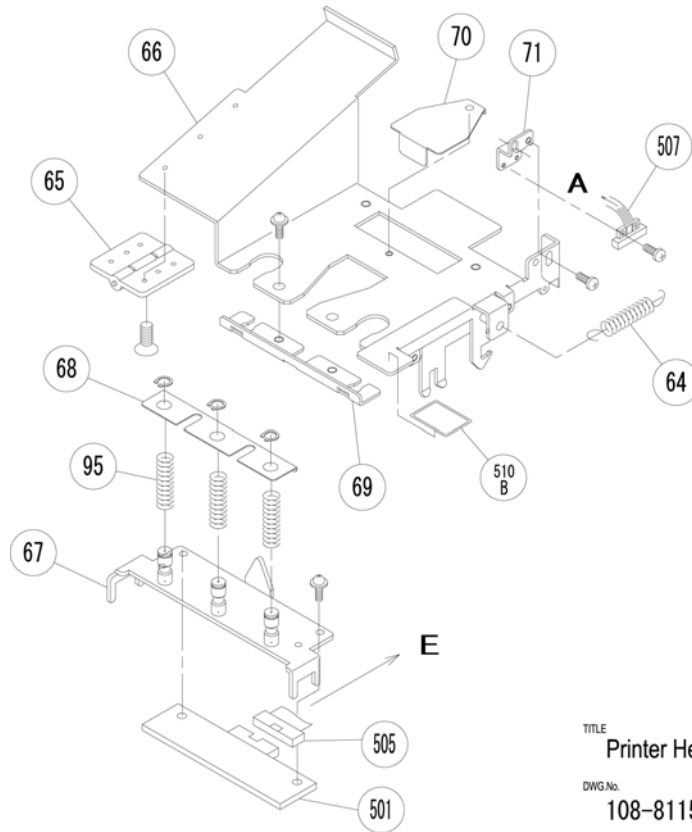

TITLE
Printer Head Assy.

DWG No.
108-8115-06

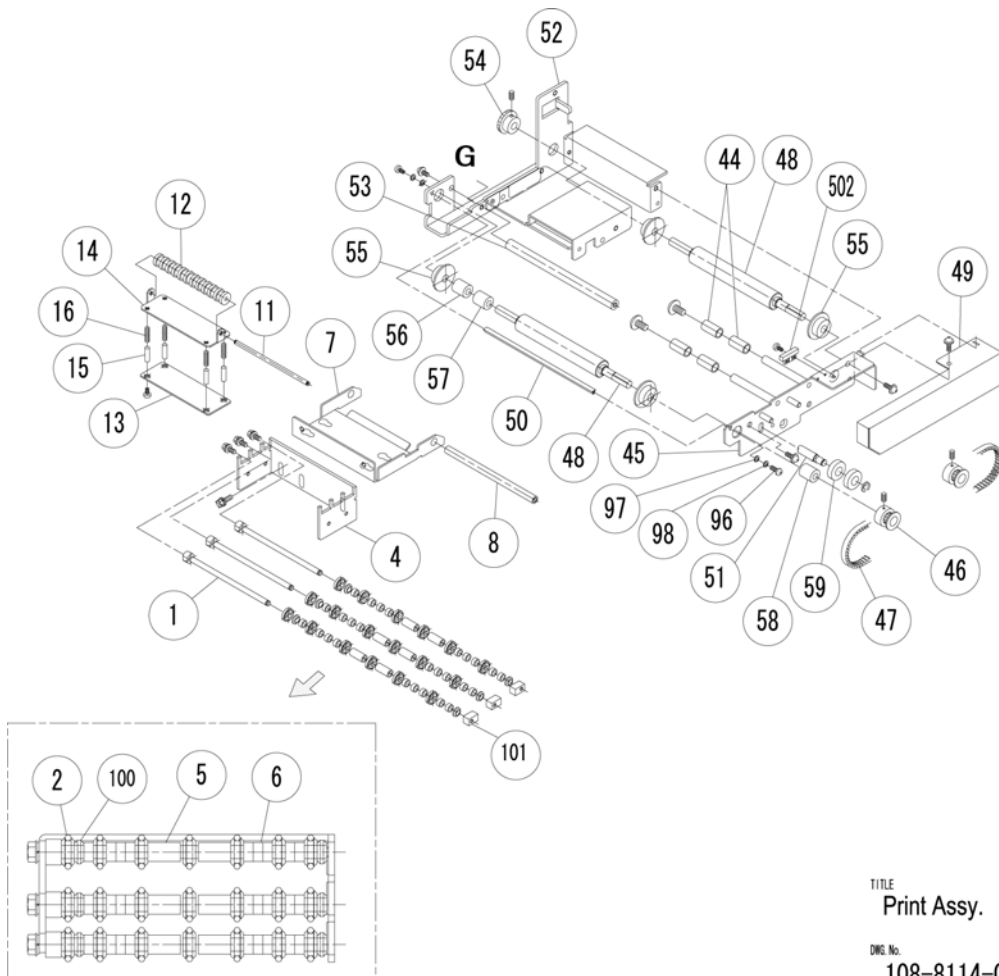

TITLE
Print Assy.

DWG No.
108-8114-02

No.	Part Name	Check Item	Number in Exploded Drawing	Recommended Period	Remarks	Required Parts	Tools/ Test program/ Oil
1-14	Heater conveyor	(1) Loose screws: Tighten the screws.		1 year			
		(2) Temperature adjustment	33-40	1 year	Replace the heater and the thermistor if any problem occurs.		
		(3) Cleaning of surface dirt on the feeder belt.	70	Every day	Replace the belt when it is remarkably dirty or expanded.		

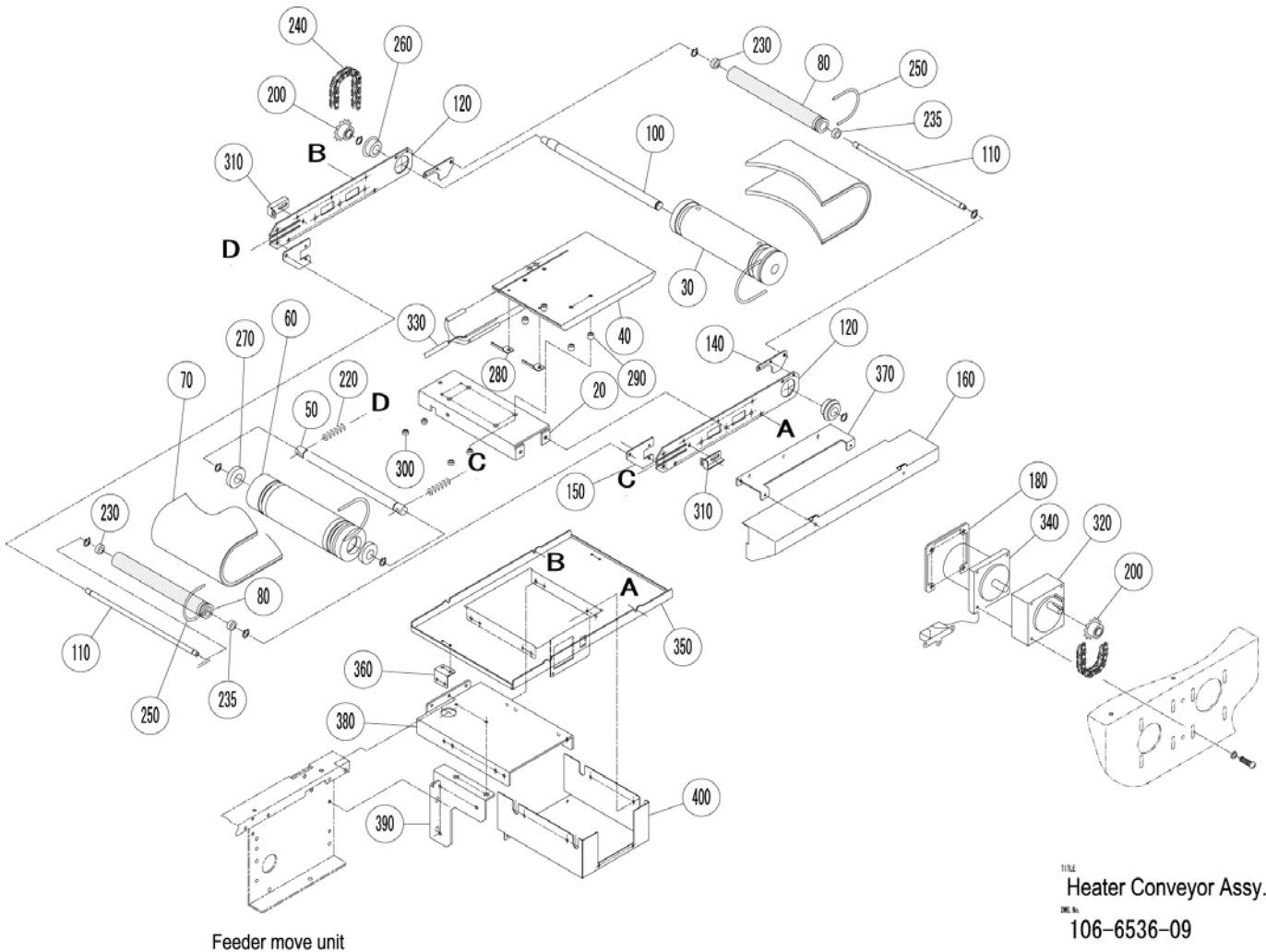

No.	Part Name	Check Item	Number in Exploded Drawing	Recommended Period	Remarks	Required Parts	Tools/ Test program/ Oil
1-15	Discharge conveyer	(1) Loose screws: Tighten the screws.		1 year			
		(2) Cleaning of surface dirt on the feeder belt.	1	1 year	Replace when it is remarkably dirty or expanded.		

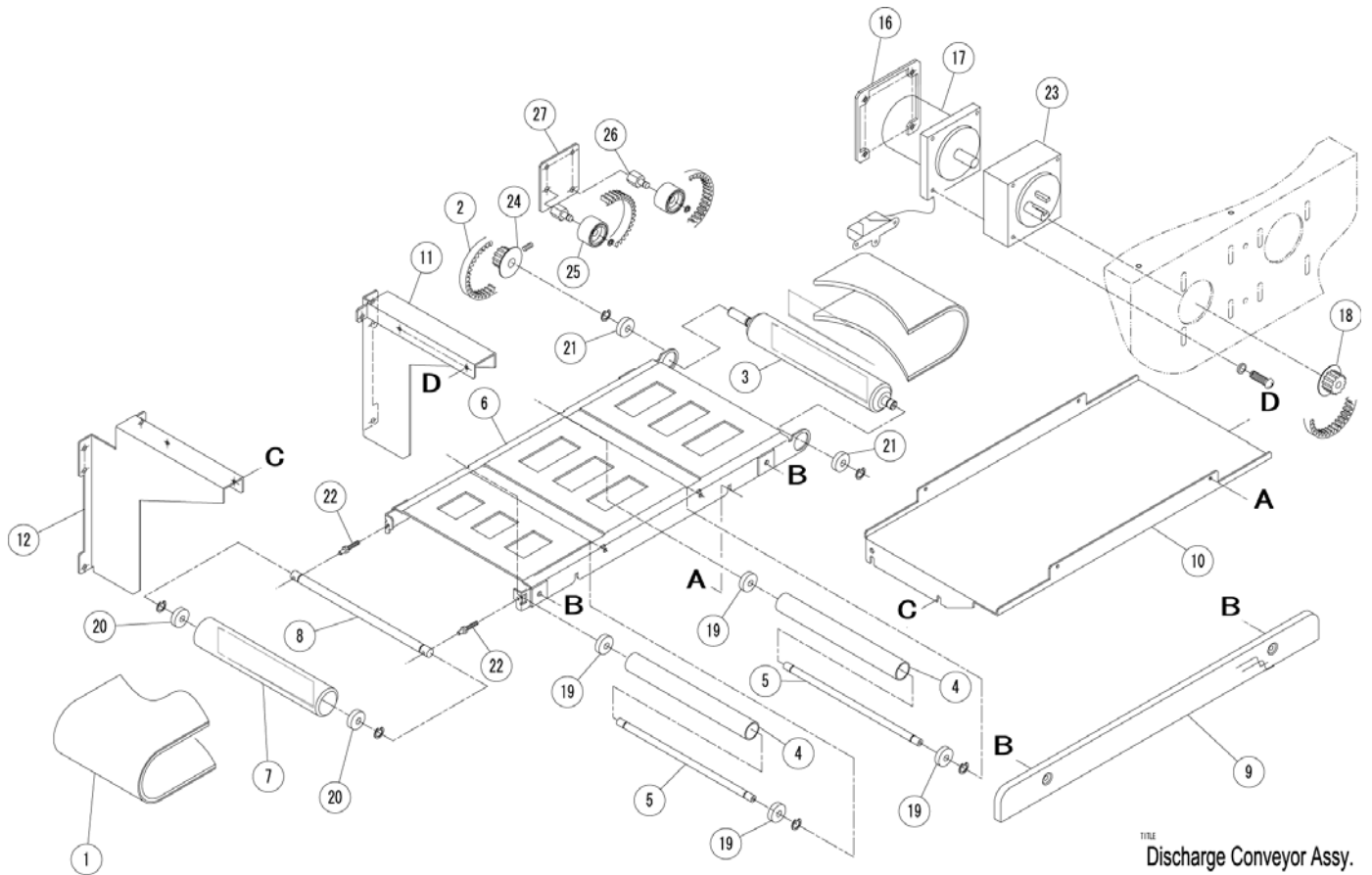

TITLE
Discharge Conveyor Assy.
DWG. No. 106-6531-01

No.	Part Name	Check Item	Number in Exploded Drawing	Recommended Period	Remarks	Required Parts	Tools/ Test program/ Oil
1-16	Display unit	(1) Touch key check		1 year			
		(2) Contrast confirmation					

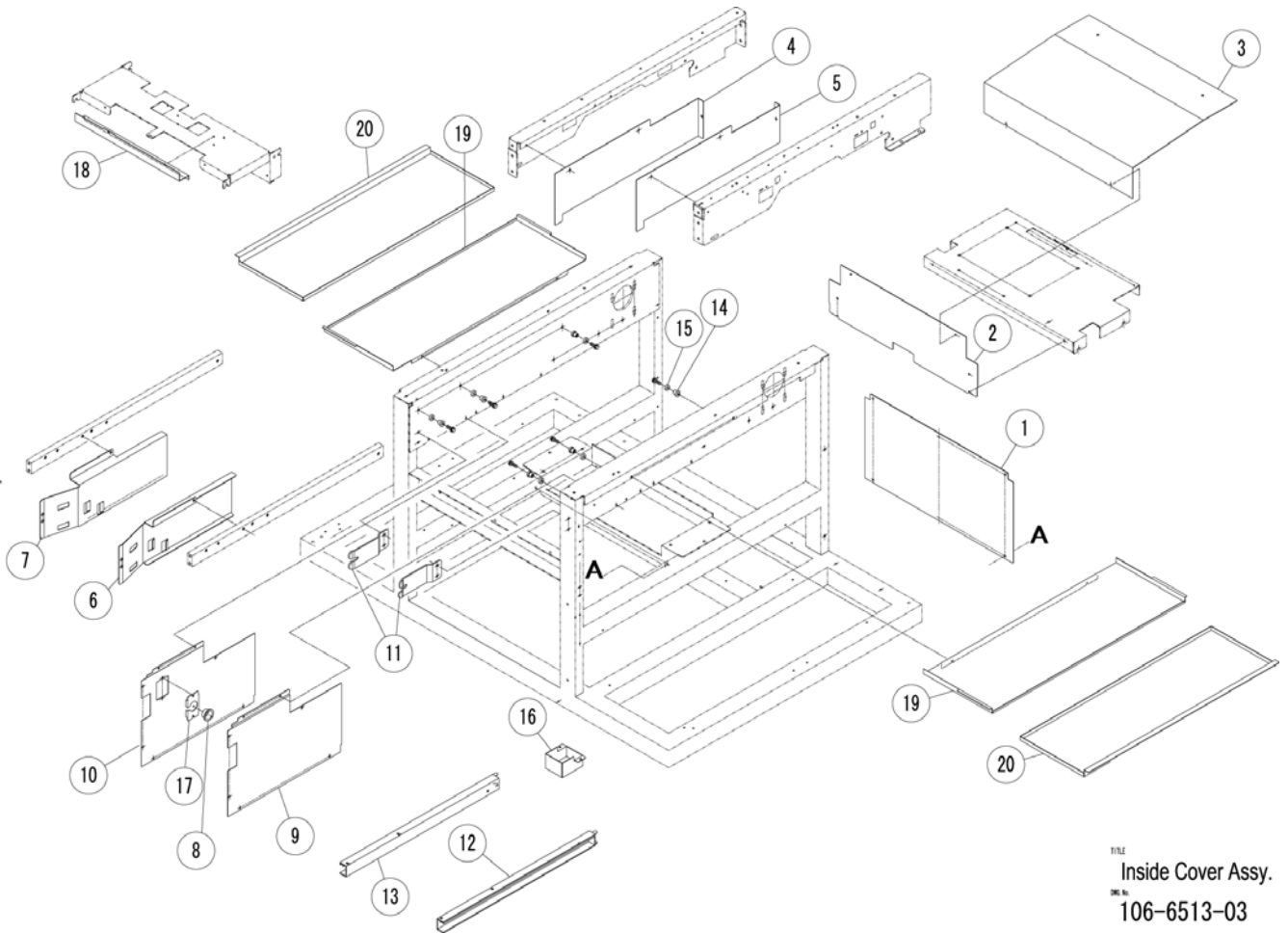

No.	Part Name	Check Item	Number in Exploded Drawing	Recommended Period	Remarks	Required Parts	Tools/ Test program/ Oil
1-17	Key unit	(1) Key check		1 year			

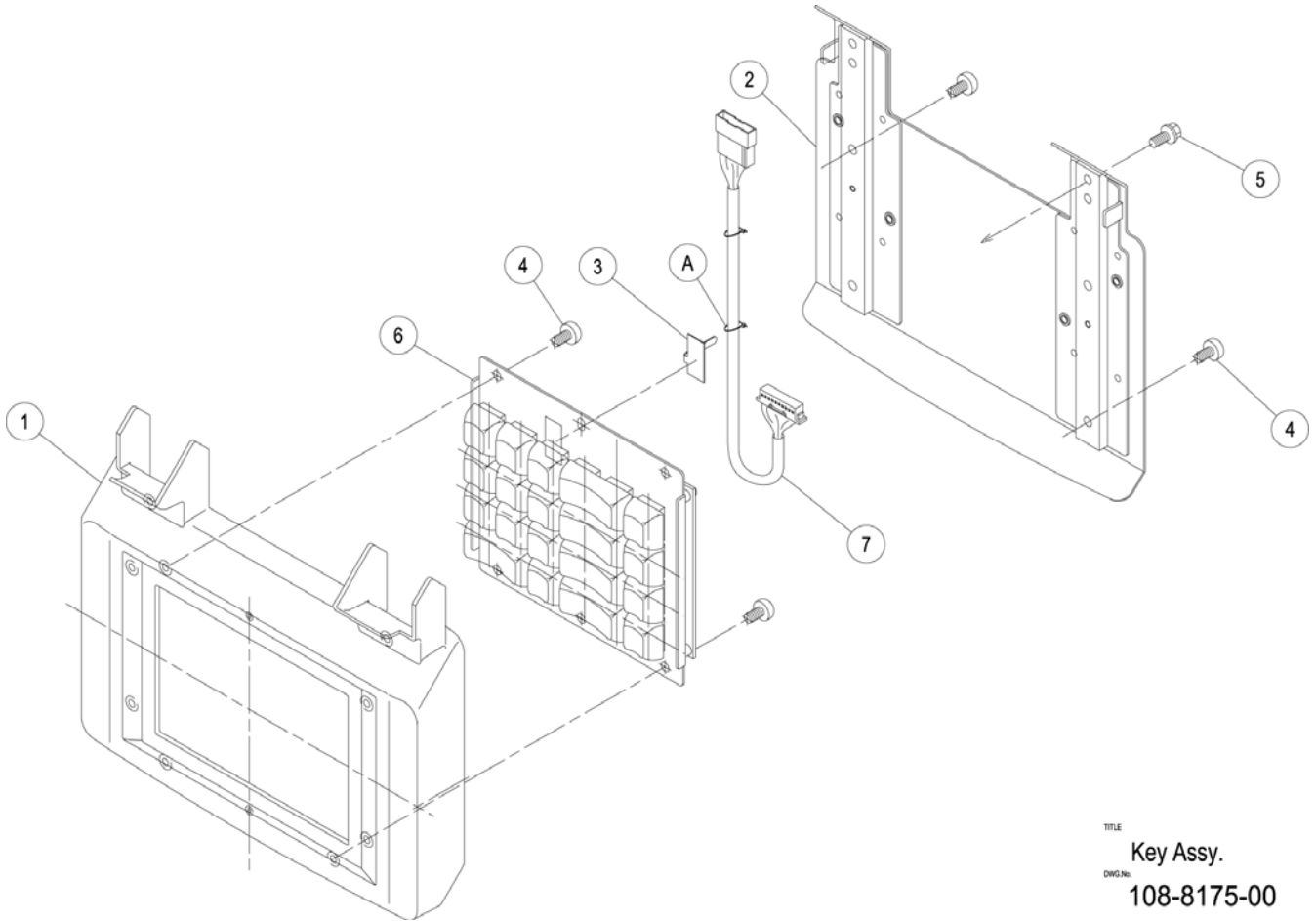

No.	Part Name	Check Item	Number in Exploded Drawing	Recommended Period	Remarks	Required Parts	Tools/ Test program/ Oil
1-18	Switch	(1) Performance of the emergency stop button.		1 year			
		(2) Each door switch		1 year			

No.	Part Name	Check Item	Number in Exploded Drawing	Recommended Period	Remarks	Required Parts	Tools/ Test program/ Oil
1-19	Connector	(1) Connection confirmation		1 year			

No.	Part Name	Check Item	Number in Exploded Drawing	Recommended Period	Remarks	Required Parts	Tools/ Test program/ Oil
1-20	Wrapping test	(1) Confirmation of the film tension and the seal condition after wrapping the tray.		0.3 year			
		(2) Confirmation of labeling state		0.3 year			

13.3 CONNECTION ASSEMBLY DIAGRAM

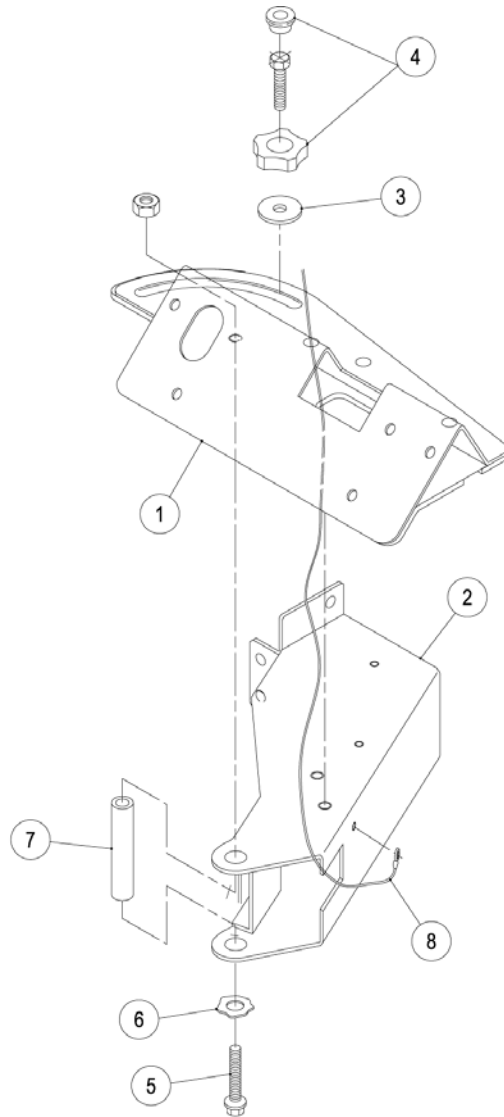
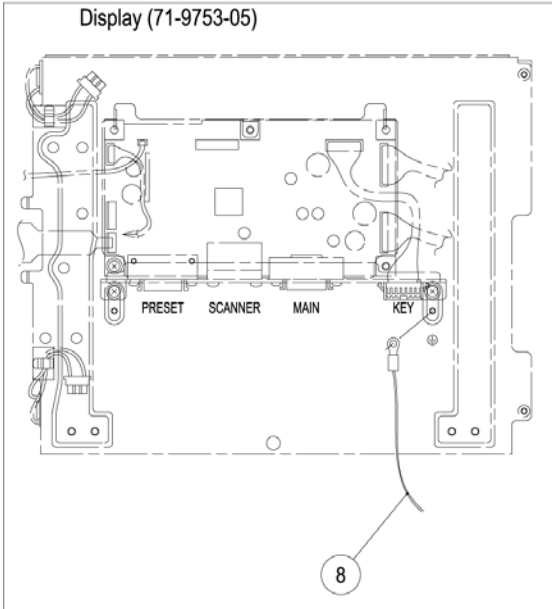

TITLE
Connection Assy.
 DWG.No.
90-0888-02

13.4 INSIDE COVER ASSEMBLY DIAGRAM

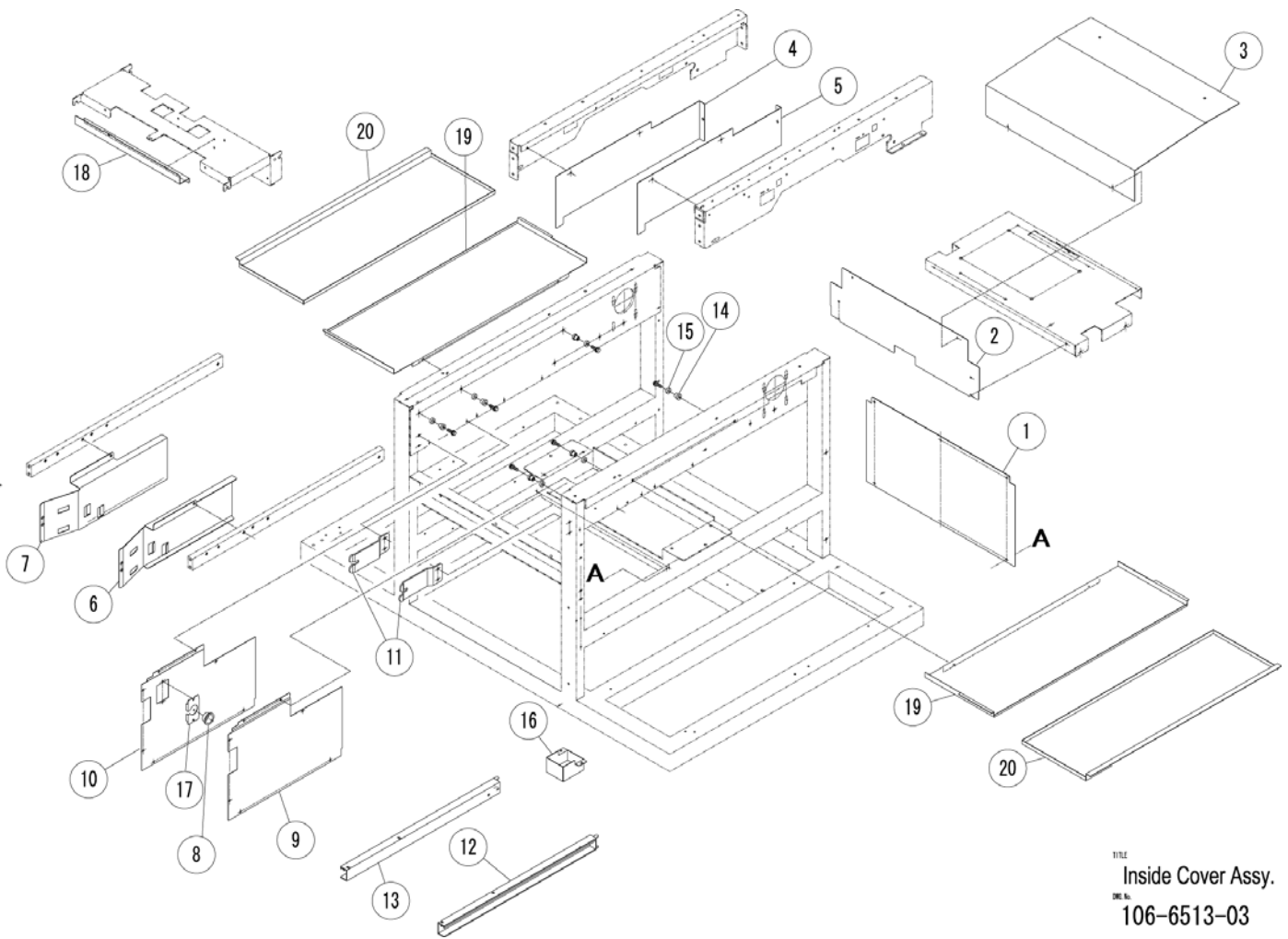

TITLE
Inside Cover Assy.
REV. No.
106-6513-03

13.5 FILM PRESS ASSEMBLY DIAGRAM

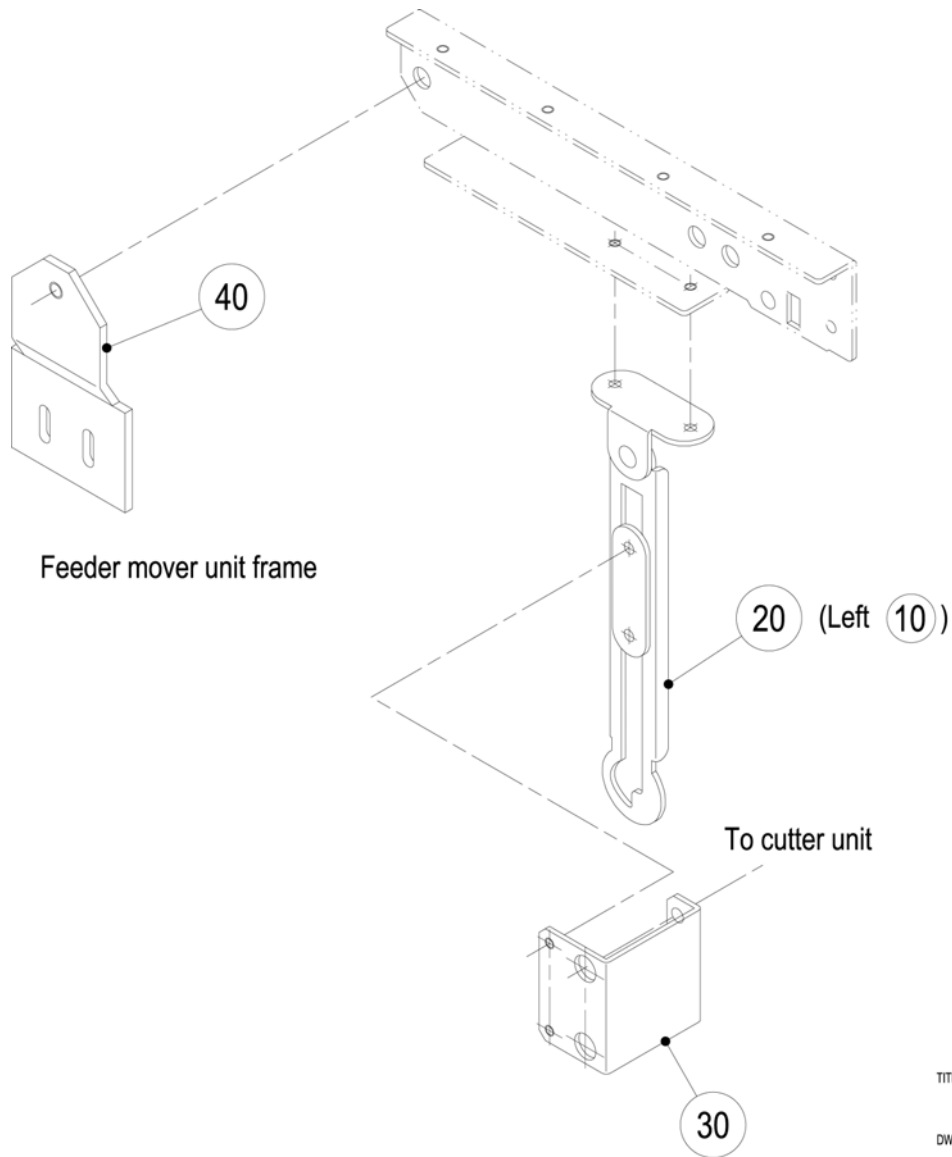

TITLE
Film Press Assy.
DWG.No.
108-8177-07

13.6 TRAY STOPPER ASSEMBLY DIAGRAM

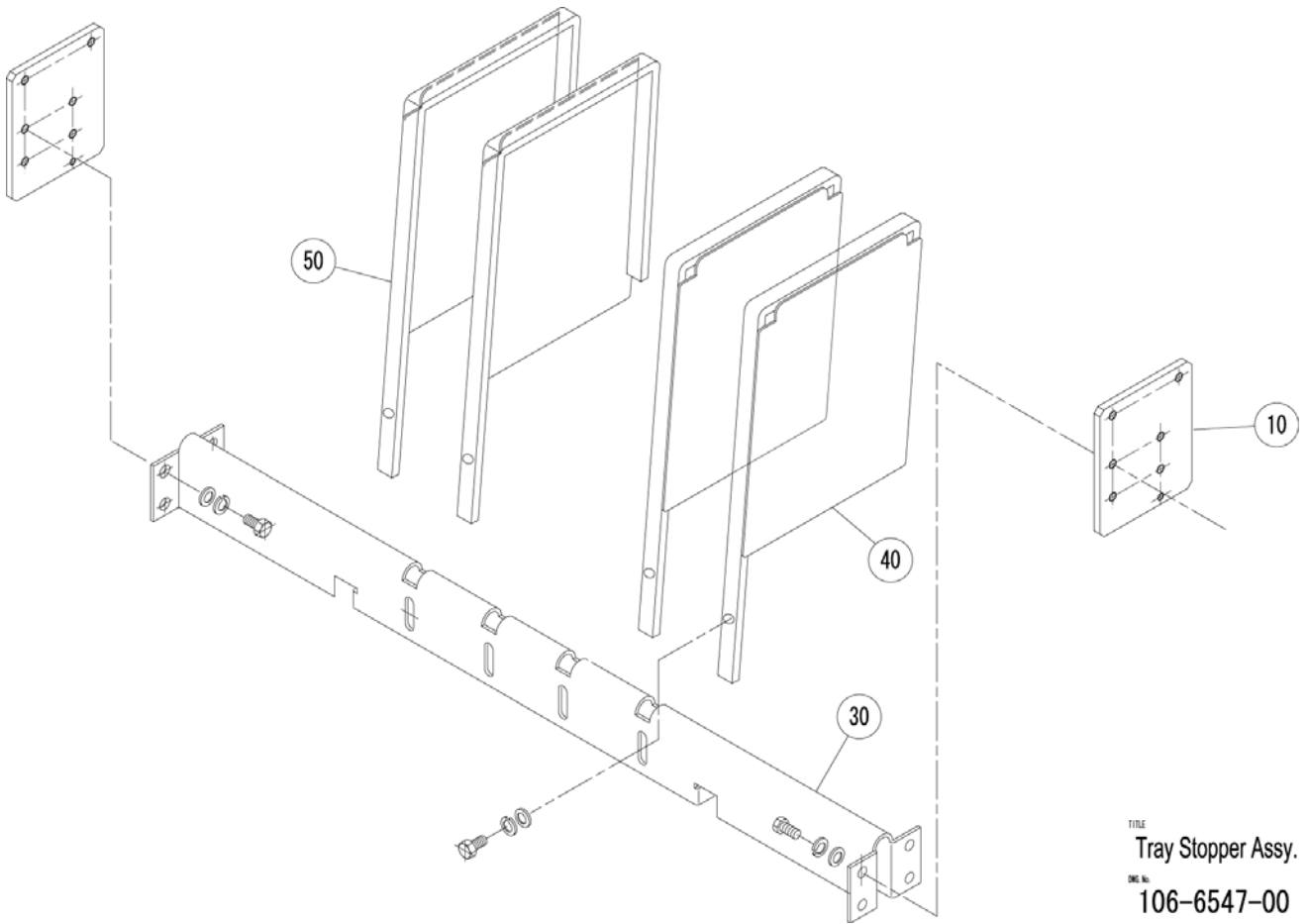

TITLE
Tray Stopper Assy.
ORG. No.
106-6547-00

13.7 PRINTER FRAME ASSEMBLY DIAGRAM

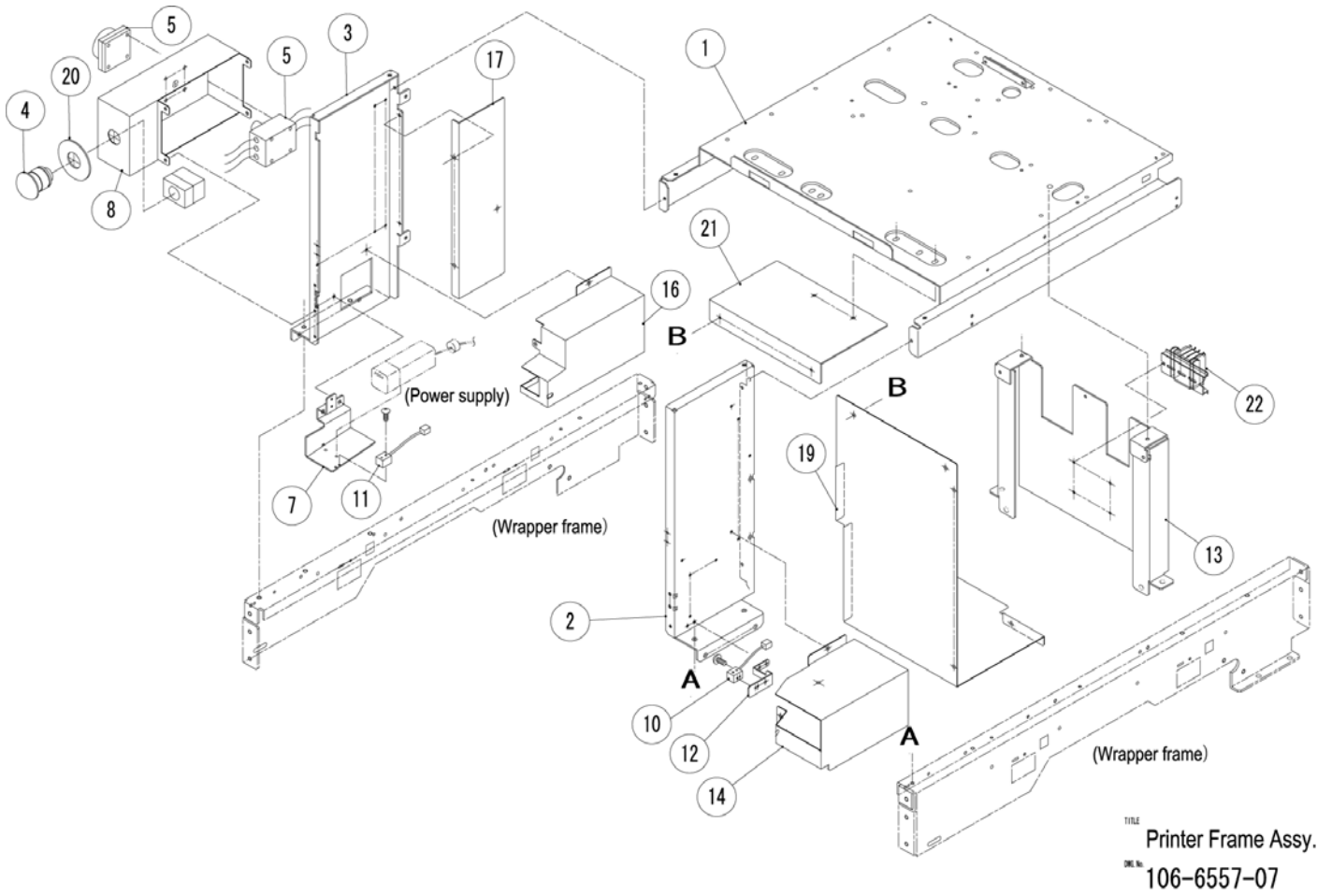

13.8 TRAY PRESS ASSEMBLY DIAGRAM

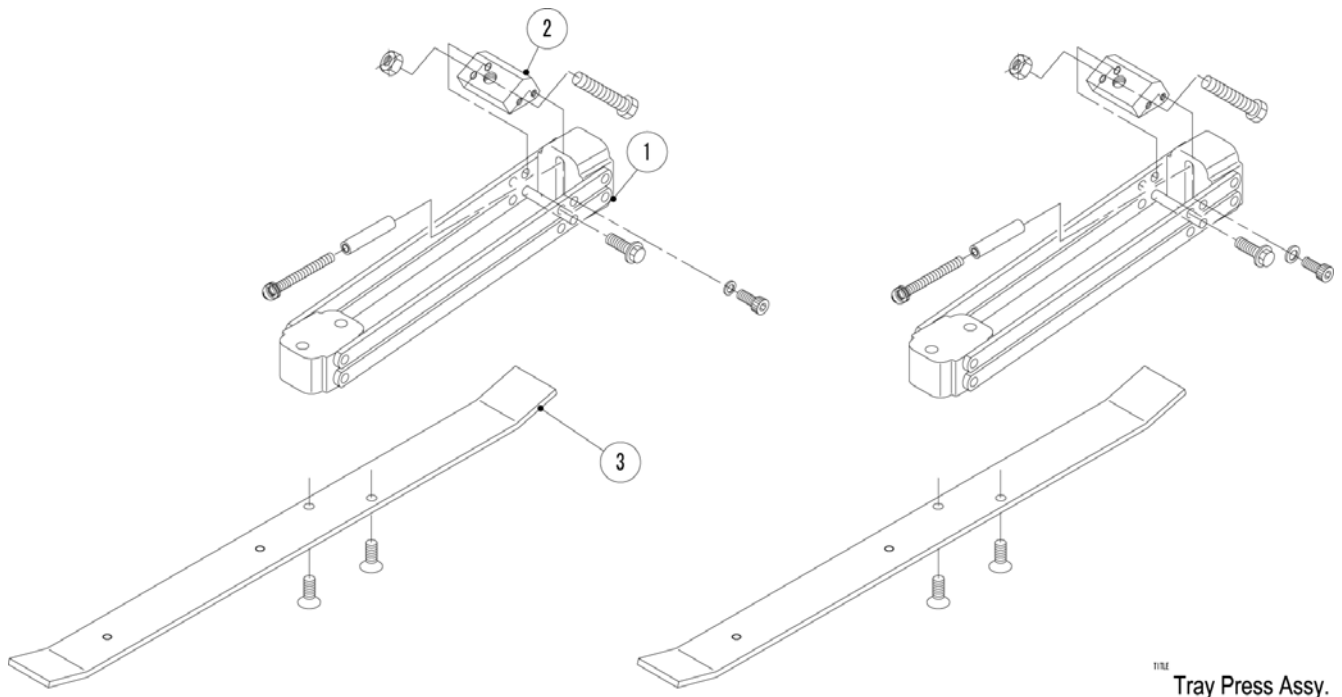

Tray Press Assy.
106-6560-09

13.9 UPPER COVER ASSEMBLY DIAGRAM

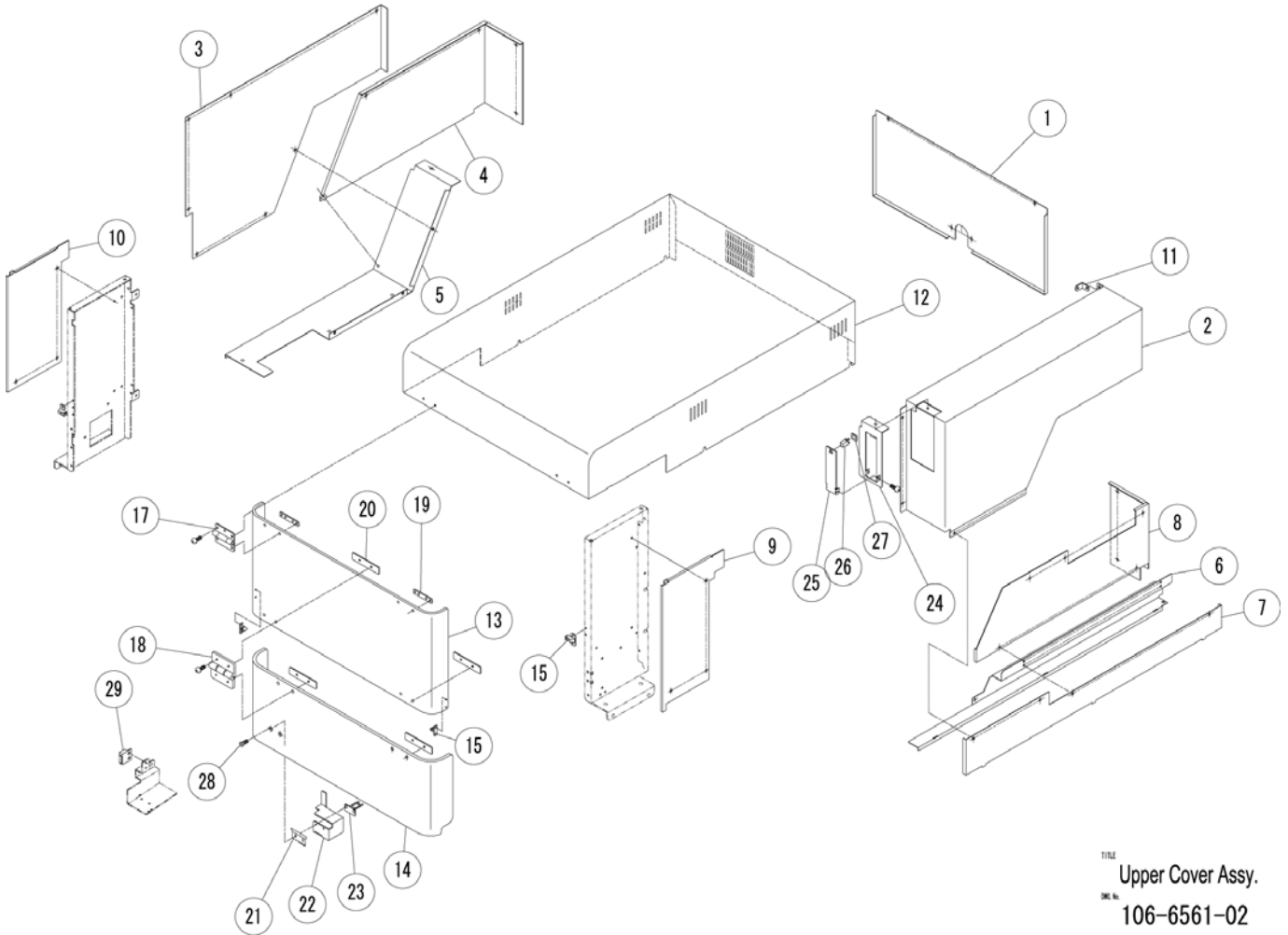

13.10 LOWER COVER ASSEMBLY DIAGRAM

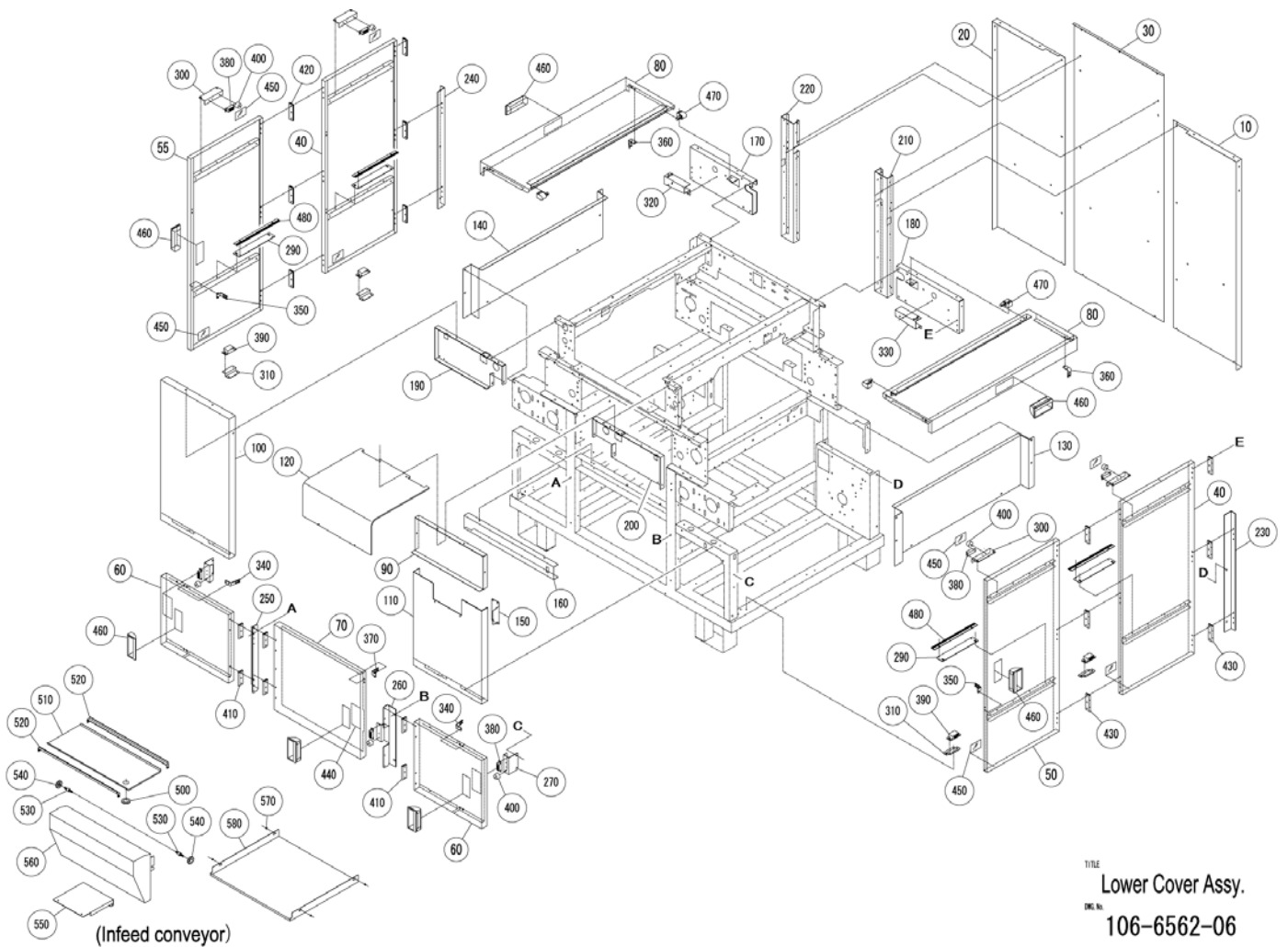

13.11 POWER SUPPLY ASSEMBLY DIAGRAM

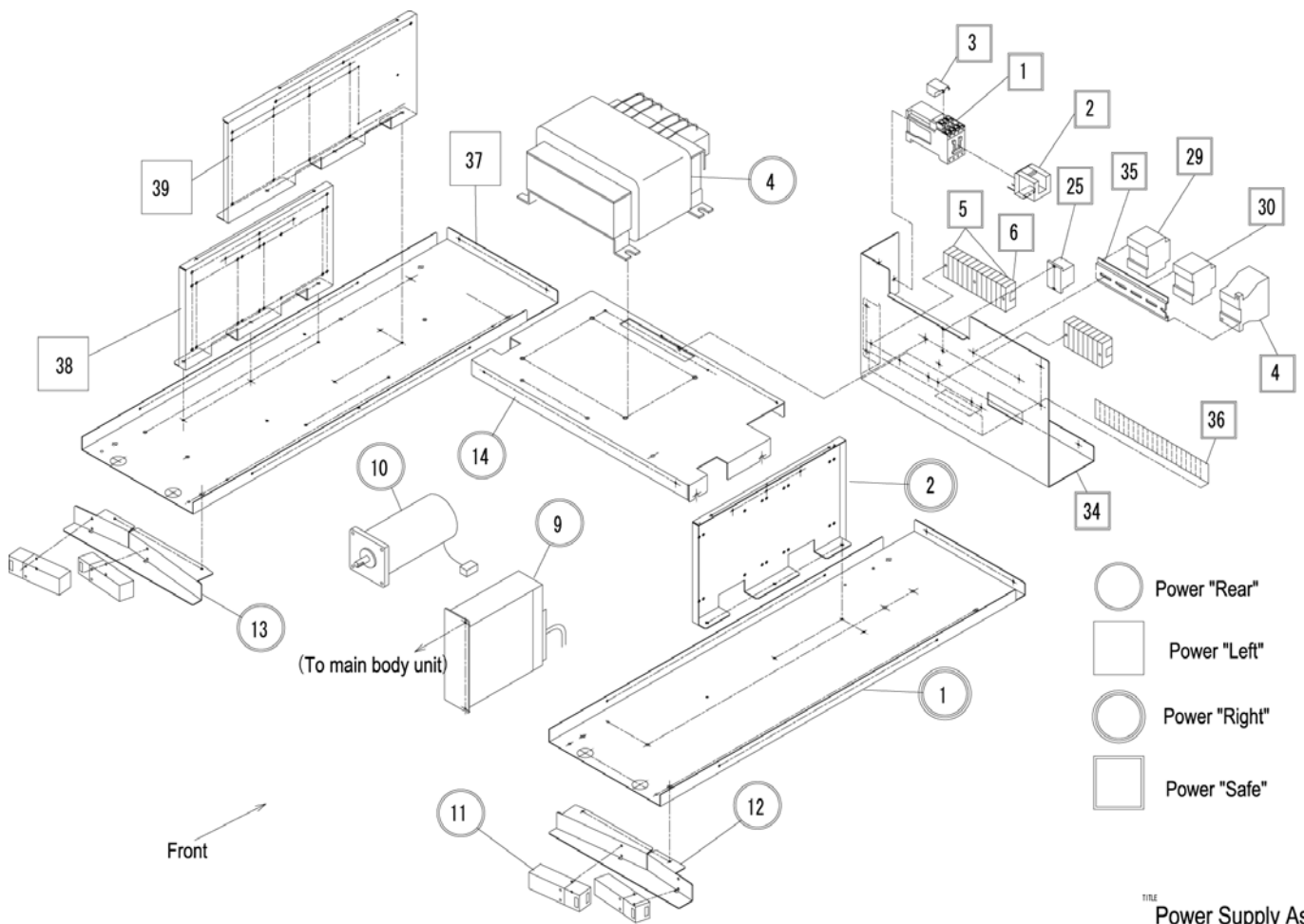

TITLE
Power Supply Assy.
REV. No.
106-6563-00

13.12 MAIN BODY ASSEMBLY DIAGRAM

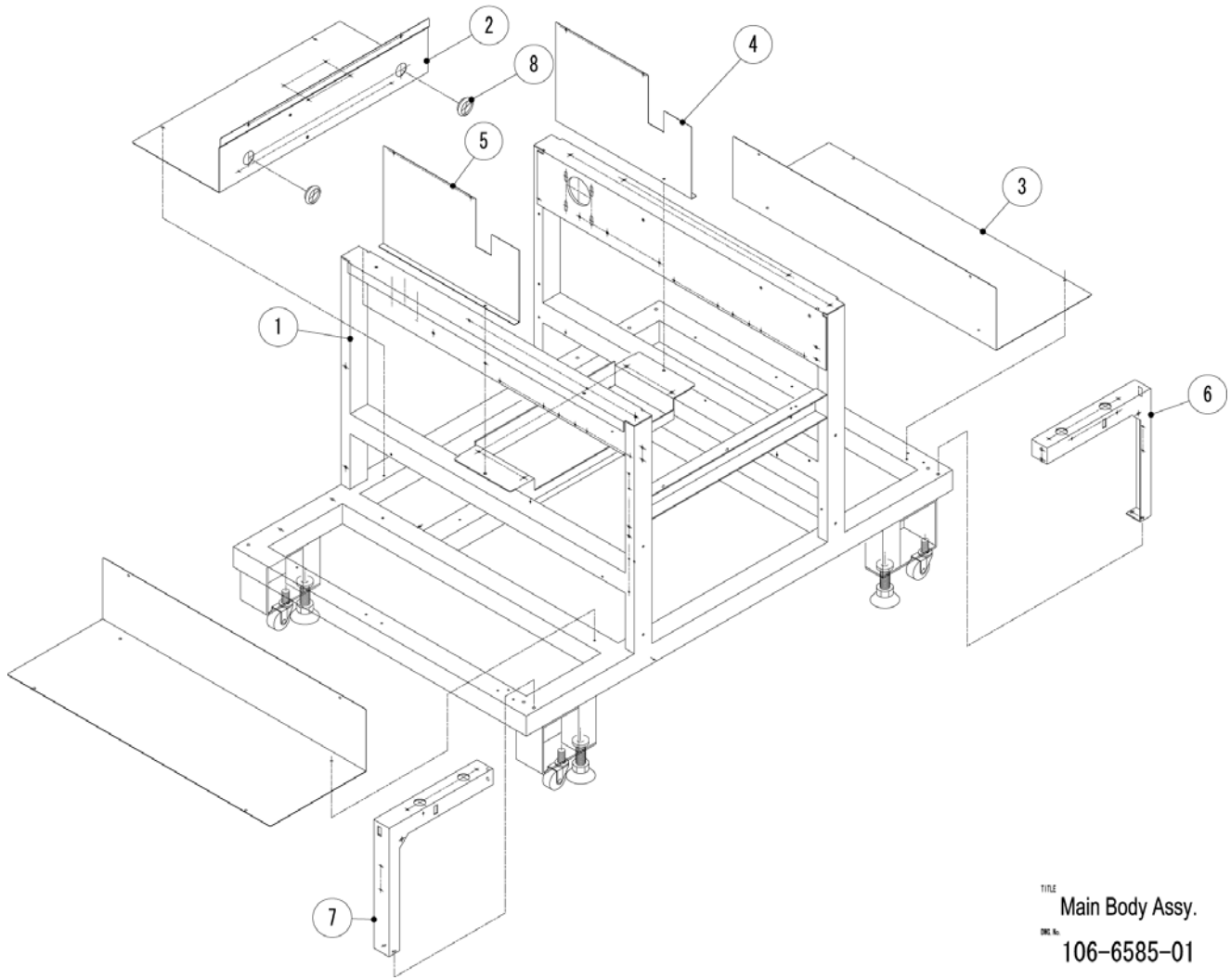

TITLE
Main Body Assy.
Dwg. No.
106-6585-01

13.13 CONTROL ASSEMBLY DIAGRAM

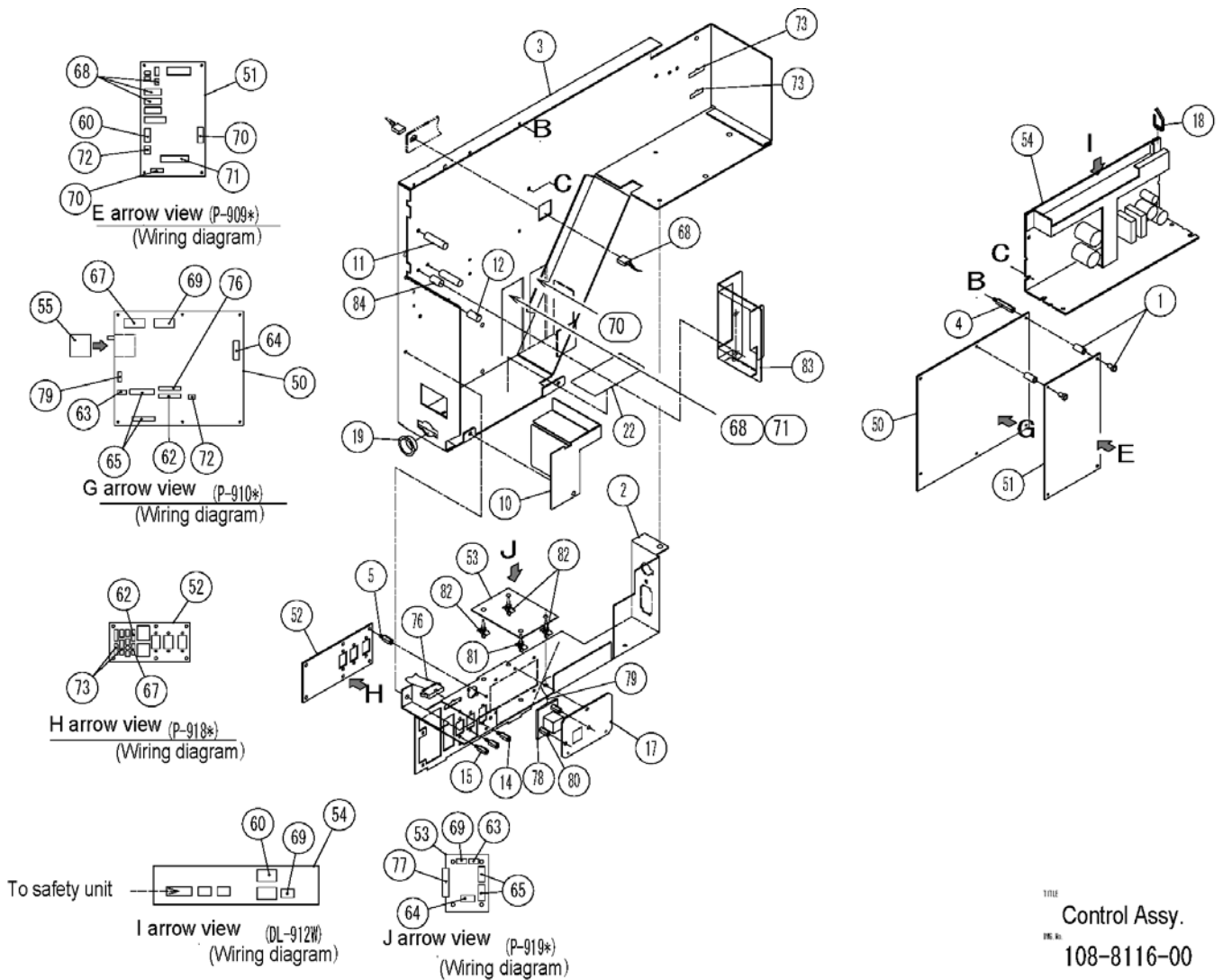

TITLE
Control Assy.
FIG. NO.
108-8116-00

13.14 FIXED APPLICATOR ASSEMBLY DIAGRAM

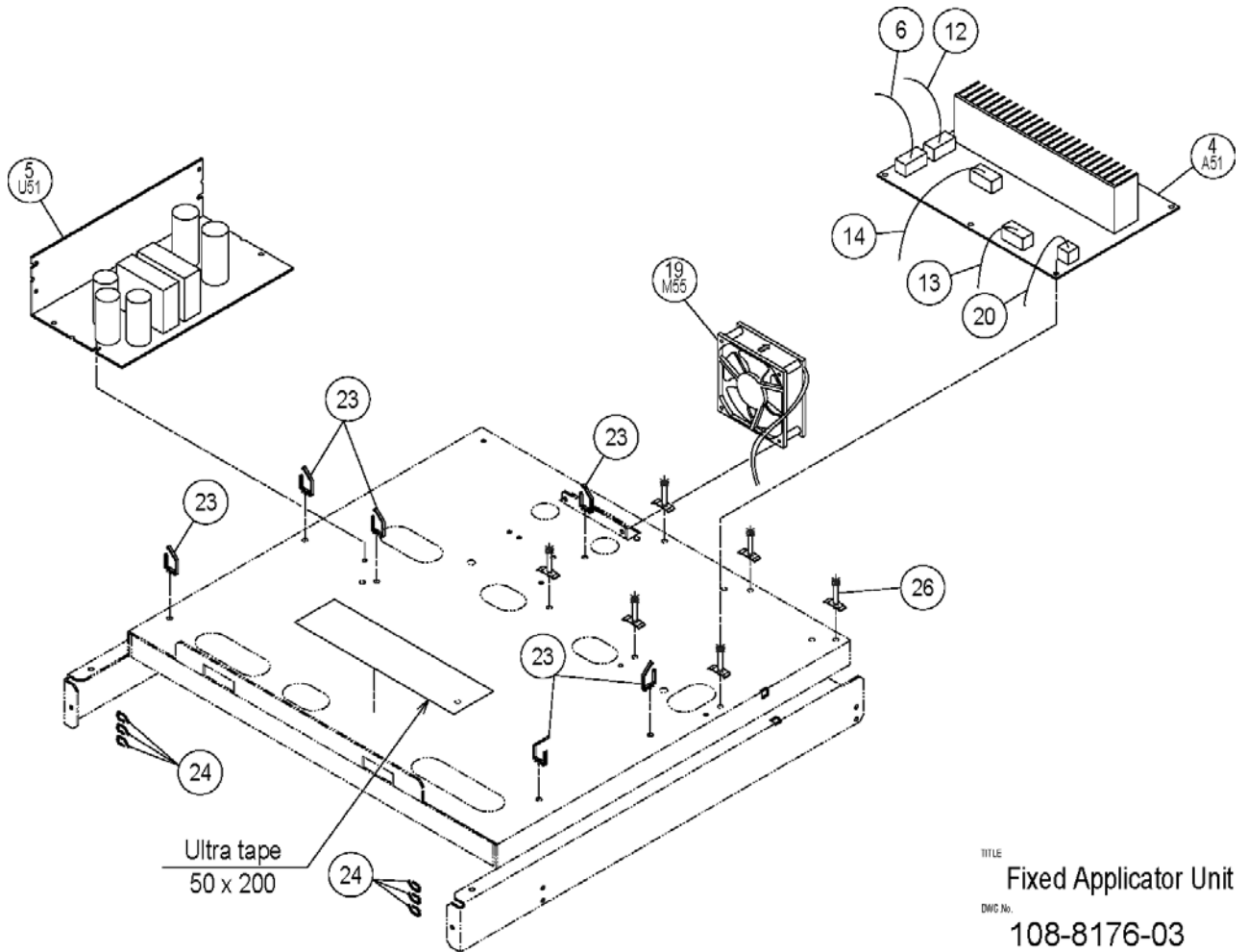

14

**ERROR
SCREENS****CONTENTS**

14.1	ERROR CODE (0100 -)	14-2
14.2	ERROR CODE (0200 -)	14-4
14.3	ERROR CODE (0300 -)	14-8
14.4	ERROR CODE (0400 -)	14-15
14.5	ERROR CODE (0600 -)	14-22
14.6	ERROR CODE (0700 -)	14-25
14.7	ERROR CODE (0800 -)	14-28
14.8	ERROR CODE (1300 -)	14-29
14.9	ERROR CODE (1400 -)	14-30
14.10	ERROR CODE (1500 -)	14-31
14.11	ERROR CODE (1600 -)	14-32
14.12	ERROR CODE (2000 -)	14-33
14.13	ERROR CODE (9000 -)	14-35

14.1 ERROR CODE (0100 -)

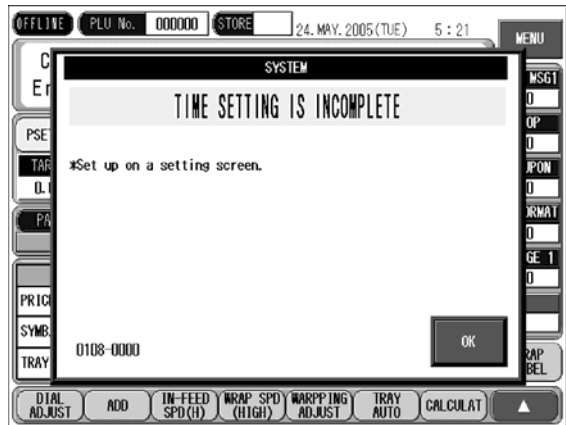
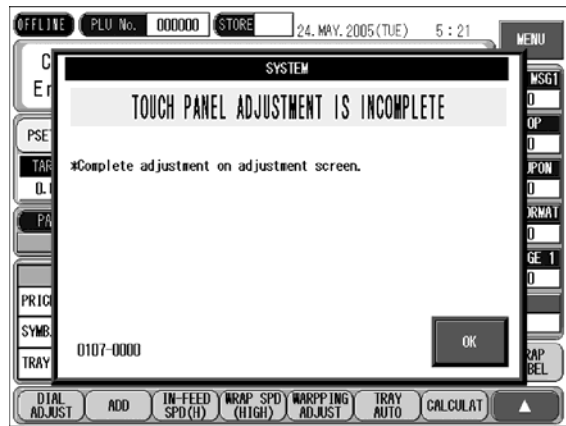
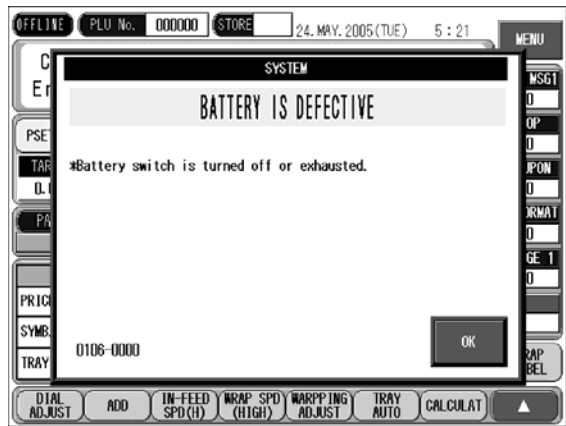
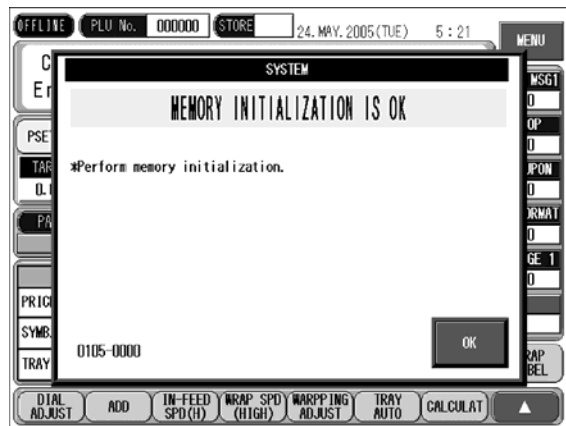
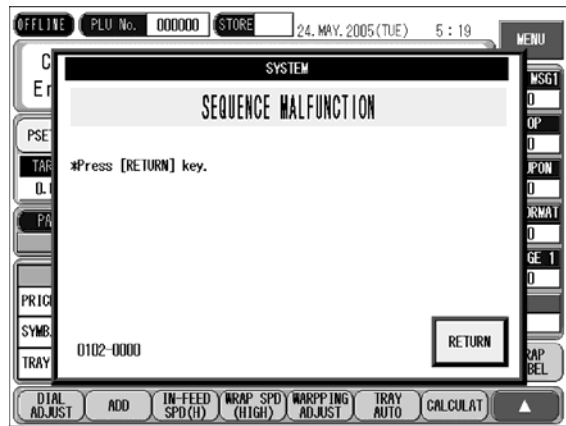
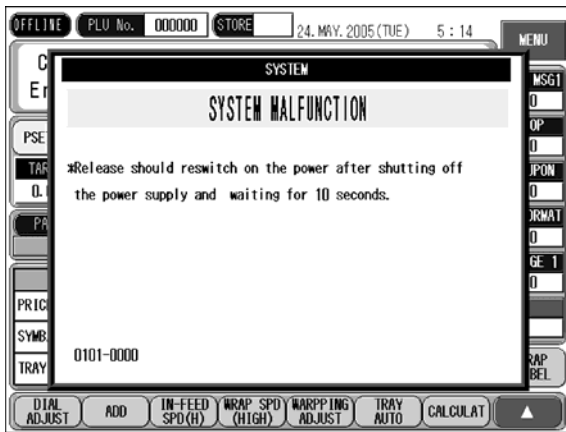

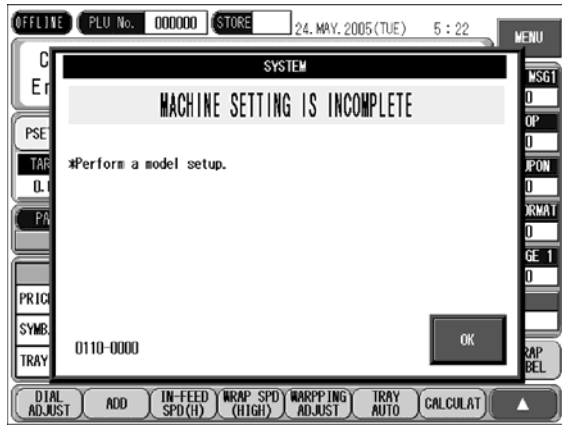

14.2 ERROR CODE (0200 -)

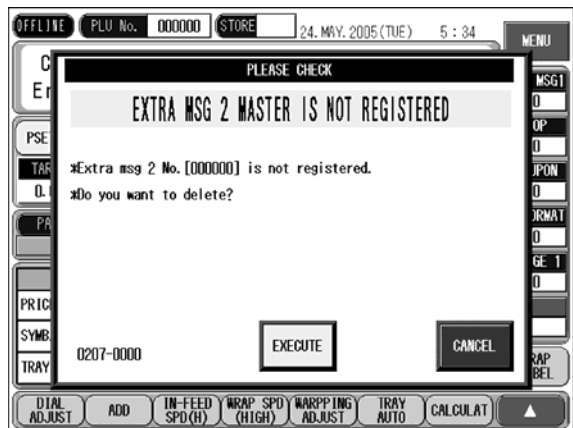
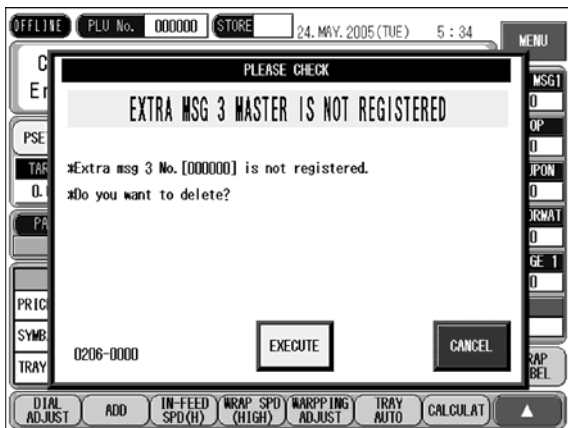
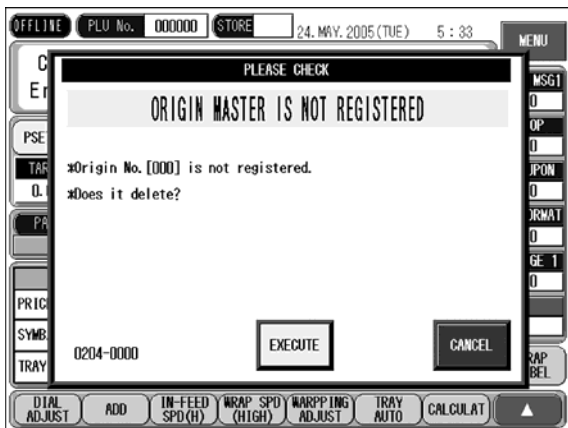
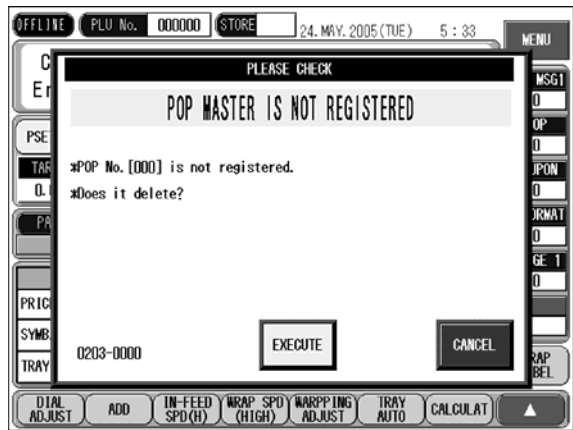

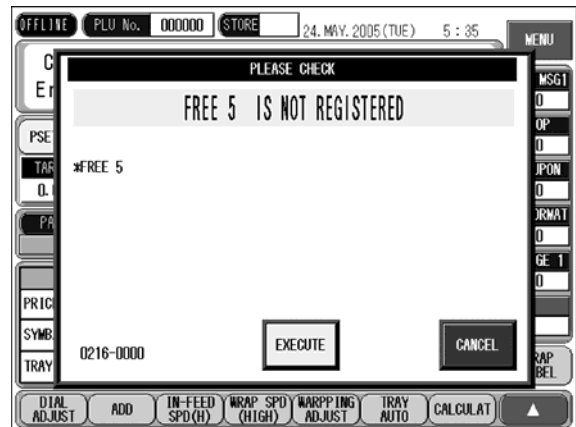
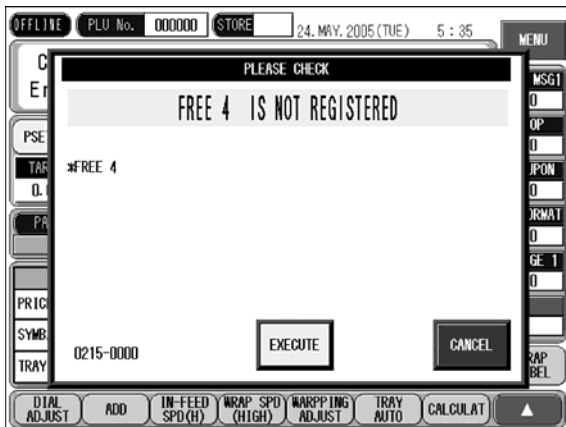
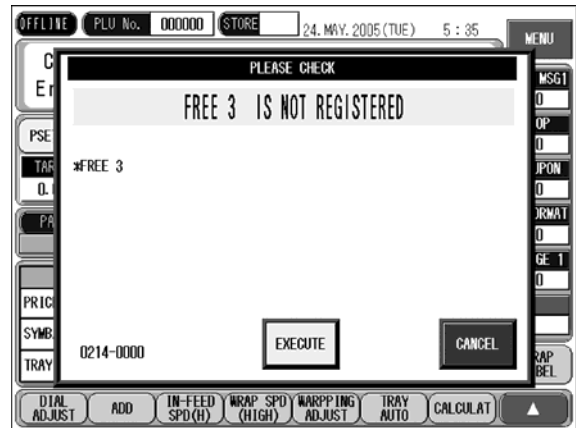
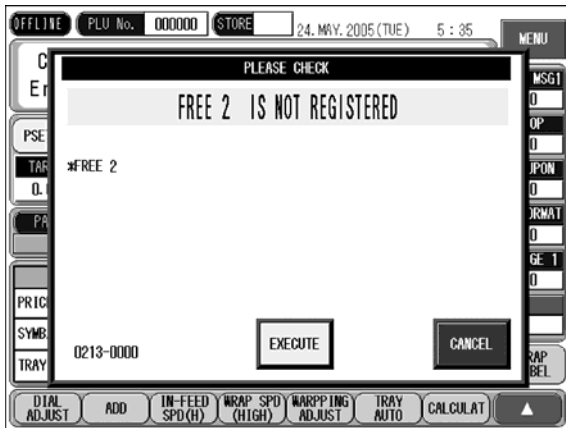
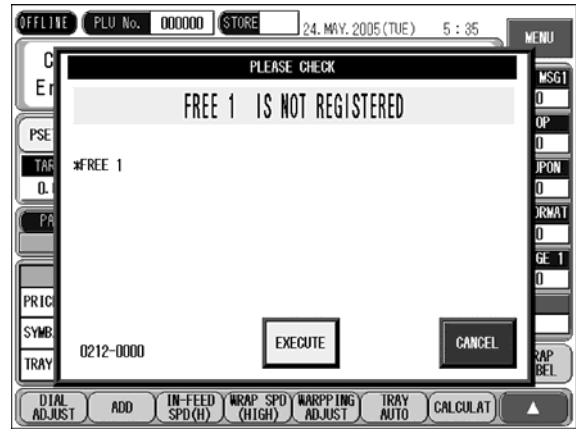

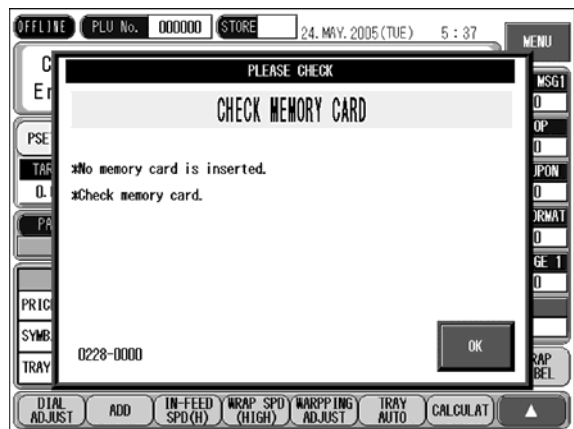
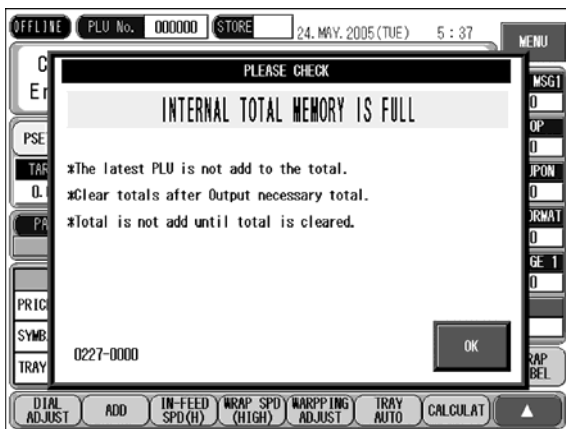
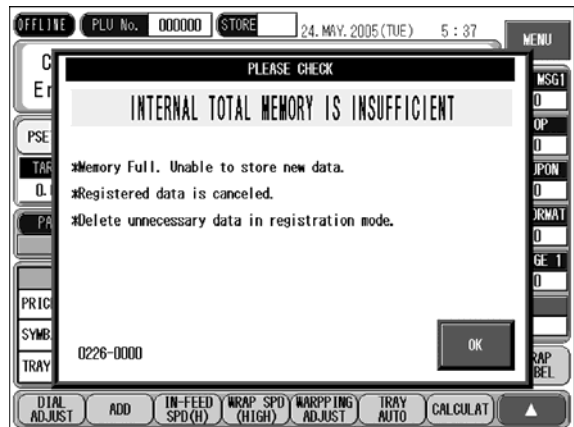
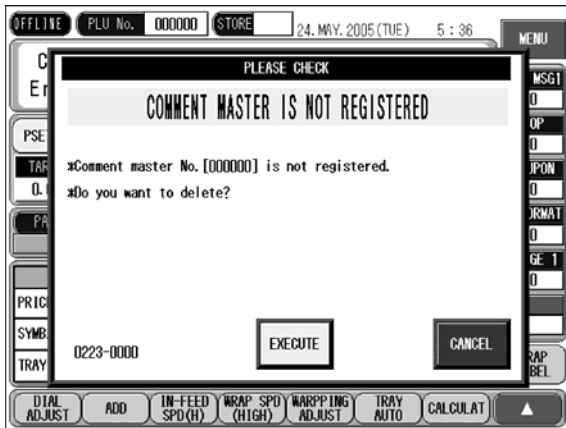
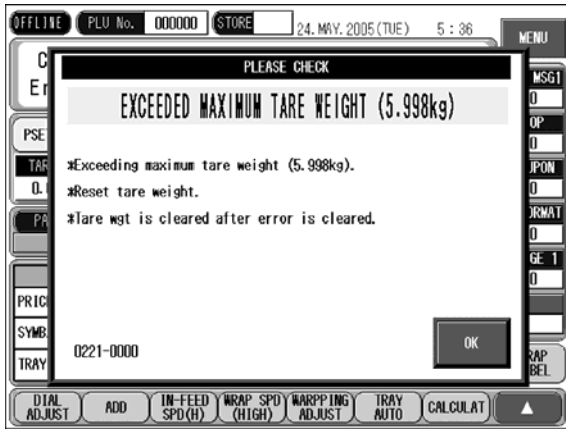

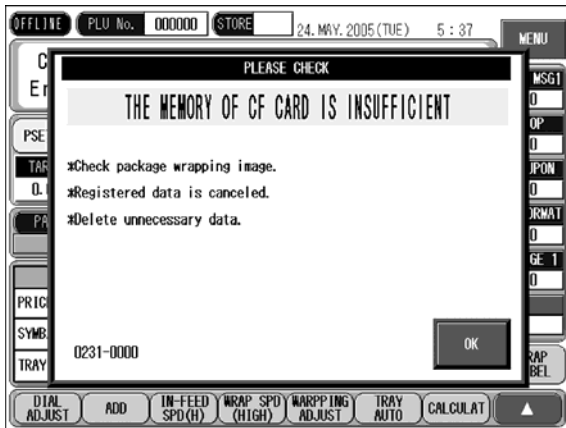

14.3 ERROR CODE (0300 -)

PACKING CONTROL PART

THE EMERGENCY STOP SWITCH IS PRESSED

#Release EMERGENCY STOP switch.

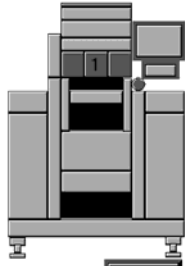

0301-0000

OK

PACKING CONTROL PART

THE EMERGENCY STOP SWITCH IS NOT PRESSED

#Press EMERGENCY STOP switch.

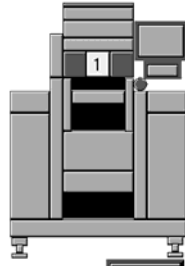

0302-0000

OK

PACKING CONTROL PART

THE FRONT COVER IS OPEN

#Close front cover.

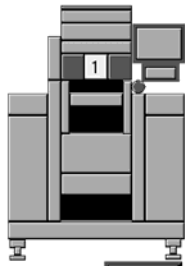

0303-0000

OK

PACKING CONTROL PART

THE INFEED LOWER COVER IS OPEN

#Close infeed lower cover.

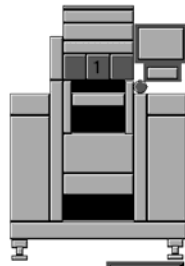

0304-0000

OK

PACKING CONTROL PART

THE INFEED COVER IS OPEN

#Close infeed cover.

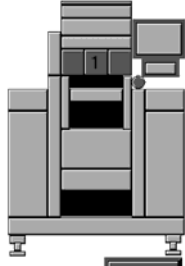

0305-0000

OK

PACKING CONTROL PART

RIGHT SIDE FILM REMOVAL DOOR IS OPEN

#Close film remove door.

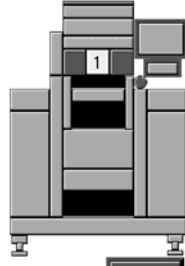

0306-0000

OK

PACKING CONTROL PART

LEFT SIDE FILM REMOVAL DOOR IS OPEN

#Close film remove door.

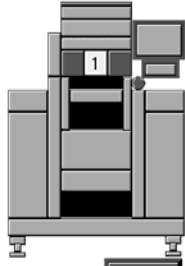

0307-0000

OK

PACKING CONTROL PART

FILM COVER IS OPEN

#Close film exchange door.

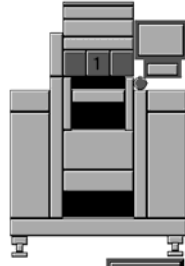

0308-0000

OK

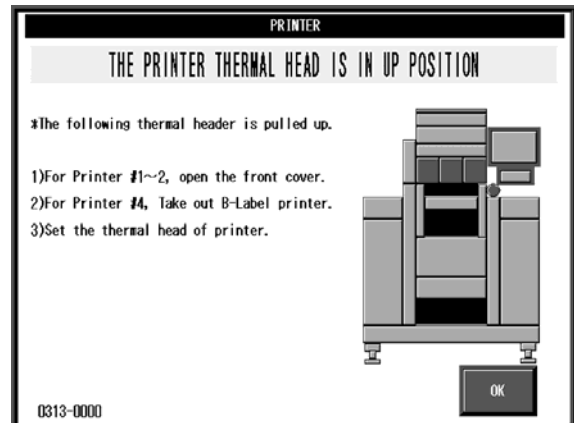
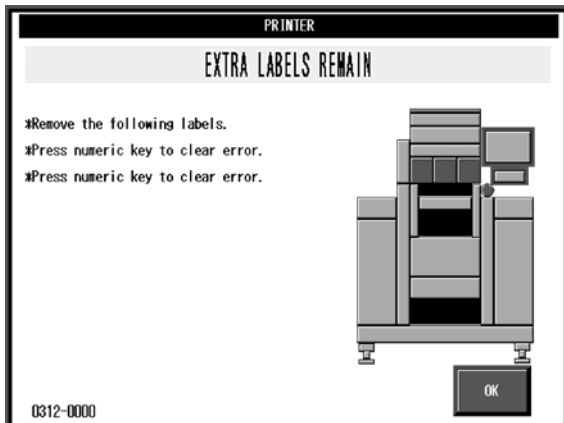
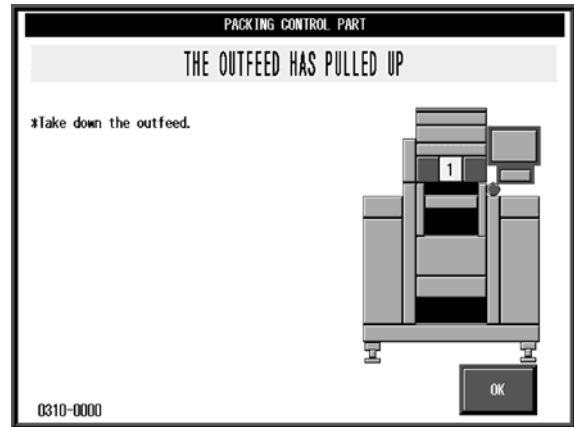
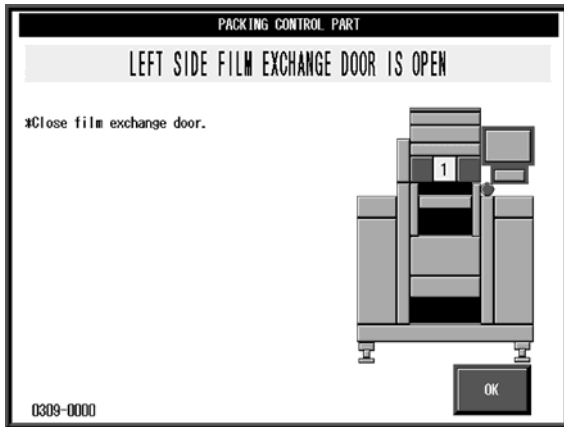

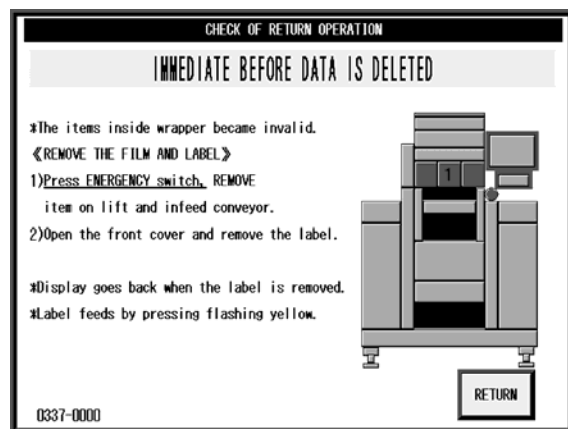
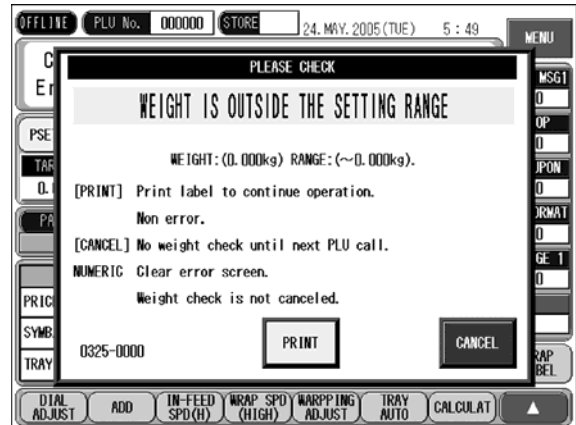
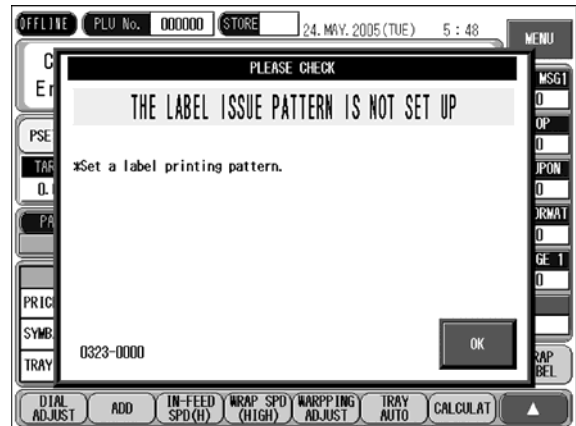
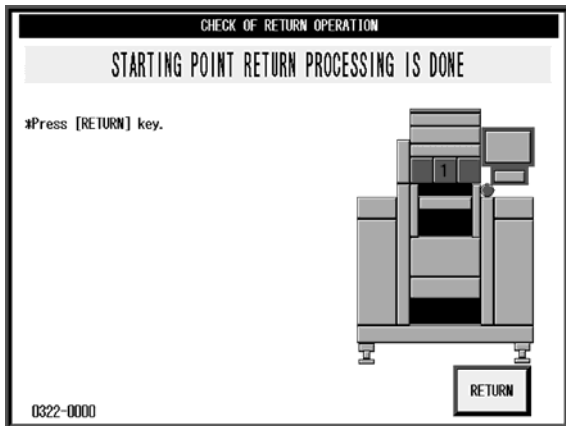
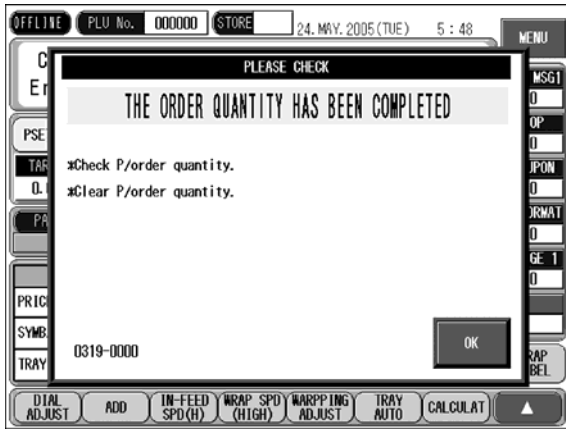

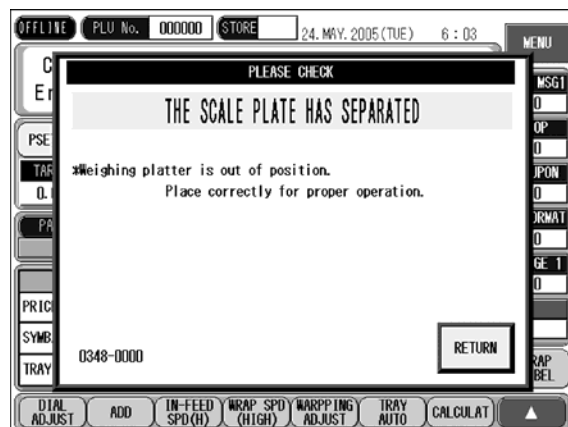
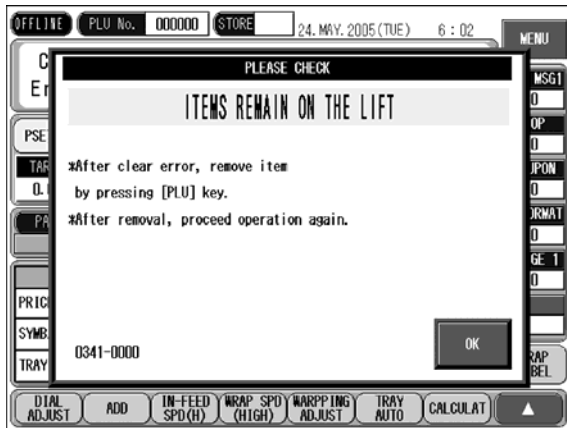
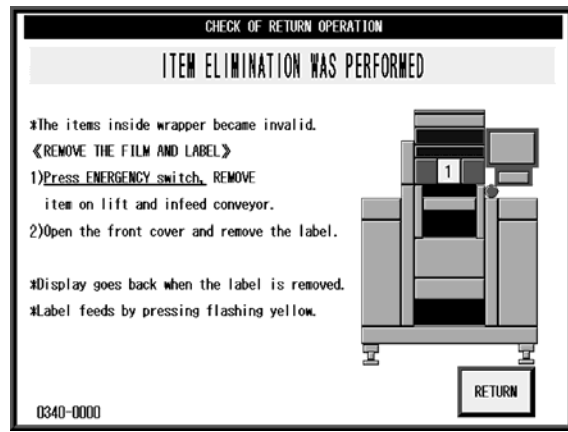
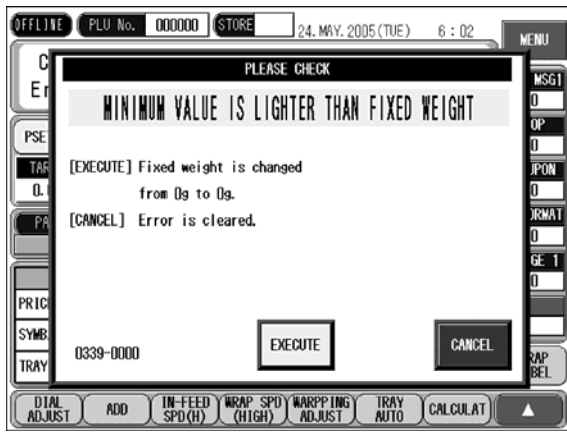

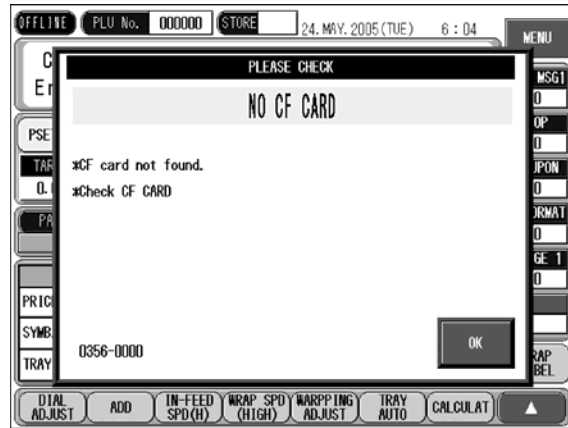
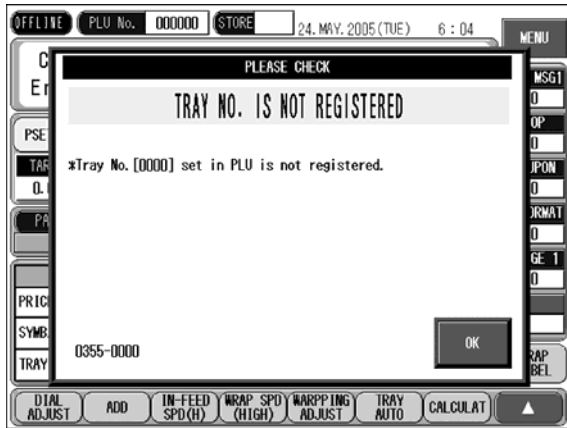

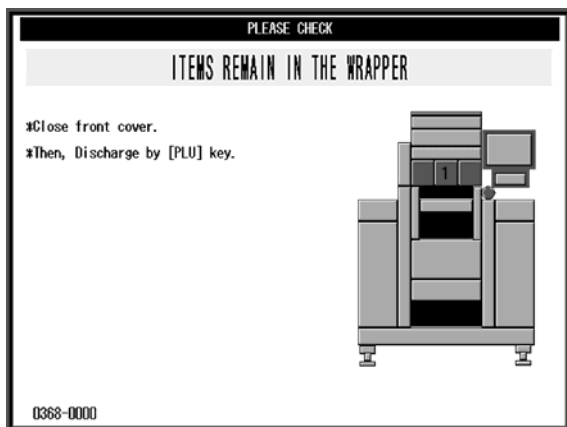

PLEASE CHECK

THE ROLLER PART IS NOT SET

*Set the B-Label roller.

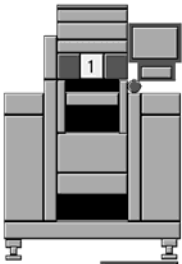

0371-0000

OK

PLEASE CHECK

CHOOSE AUTO-PASTE / DP MODE

*AUTO LABELING → Close the front cover,
Set the printer #4(B-Label).

*DP mode → Open the front cover,
Pull out the printer #4(B-Label)

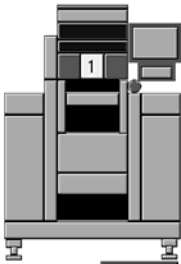

0372-0000

OK

PLEASE CHECK

SET A STOCK PART

*PLU with B-Label
It is necessary to set a stock part.
*Set it to clear error.

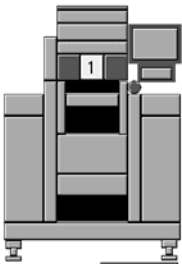

0373-0000

OK

PLEASE CHECK

PRODUCE IN DP MODE

*The machine is set as manual labeling.
*Able to operate in DP Mode.
*Open the front cover,
Pull out the printer #4(B-Label)

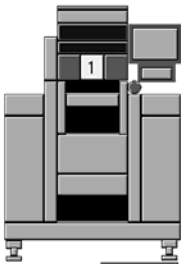

0374-0000

OK

PLEASE CHECK

PRODUCE IN DP MODE

*The machine can operate in DP Mode only.
*Open the front cover,
Pull out the printer #4(B-Label)

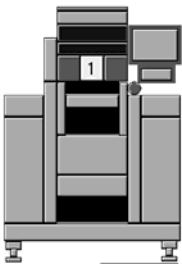

0375-0000

OK

14.4 ERROR CODE (0400 -)

PACKING CONTROL PART

THE WRAPPER IS NOT CONNECTED

#Confirm the connection with wrapper.
 1) Press [RE-TRY] key.
 2) Press [OK] key if error is not canceled.
 3) In this case, only the labeling is able to operate.

0401-0000

OK RE-TRY

PACKING CONTROL PART

THERE WAS NO RESPONSE FROM WRAPPER

#Confirm the connection with wrapper.
 1) Press [RE-TRY] key.
 2) Press [OK] key if error is not canceled.
 3) In this case, only the labeling is able to operate.

0402-0000

OK RE-TRY

PACKING CONTROL PART

THE PROBLEM AROSE IN WRAPPER

#Release should reswitch on the power after shutting off the power supply and waiting for 10 seconds.
 #Send command and receive command does not match.

0403-0000

PACKING CONTROL PART

THE WRAPPER DETECTED THE INSTANT POWER FAILURE

#Release should reswitch on the power after shutting off the power supply and waiting for 10 seconds.

0406-0000

PACKING CONTROL PART

THE INSTANT POWER FAILURE OCCURRED BY THE CONSOLE

#Release should reswitch on the power after shutting off the power supply and waiting for 10 seconds.

0407-0000

PACKING CONTROL PART

THERE WAS NO RESPONSE FROM WRAPPER

#Confirm the connection with wrapper.
 1) Press [RE-TRY] key.
 2) Press [OK] key if error is not canceled.
 3) In this case, only the labeling is able to operate.

0409-0000

OK RE-TRY

PACKING CONTROL PART

THE LIFT MOTOR ERROR

《REMOVE THE FILM AND LABEL》
 1) Press EMERGENCY switch, REMOVE item on lift and infeed conveyor.
 2) Open the front cover and remove the label.

#Display goes back when the label is removed.
 #Label feeds by pressing flashing yellow.

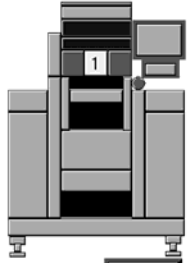

0410-0000

RETURN

PACKING CONTROL PART

THE RIGHT FILM PLUG MOTOR ERROR

《REMOVE THE FILM AND LABEL》
 1) Press EMERGENCY switch, REMOVE item on lift and infeed conveyor.
 2) Open the front cover and remove the label.

#Display goes back when the label is removed.
 #Label feeds by pressing flashing yellow.

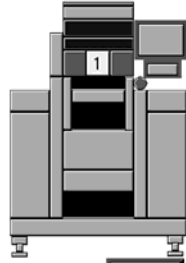

0411-0000

RETURN

PACKING CONTROL PART

THE LEFT FILM PLUG MOTOR ERROR

《REMOVE THE FILM AND LABEL》

- 1) Press EMERGENCY switch, REMOVE item on lift and infeed conveyor.
- 2) Open the front cover and remove the label.

※Display goes back when the label is removed.
 ※Label feeds by pressing flashing yellow.

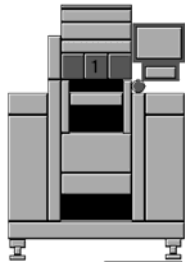

RETURN

0412-0000

PACKING CONTROL PART

THE RIGHT FILM ROLLER DRIVER MOTOR ERROR

《REMOVE THE FILM AND LABEL》

- 1) Press EMERGENCY switch, REMOVE item on lift and infeed conveyor.
- 2) Open the front cover and remove the label.

※Display goes back when the label is removed.
 ※Label feeds by pressing flashing yellow.



RETURN

0413-0000

PACKING CONTROL PART

THE LEFT FILM ROLLER DRIVER MOTOR ERROR

《REMOVE THE FILM AND LABEL》

- 1) Press EMERGENCY switch, REMOVE item on lift and infeed conveyor.
- 2) Open the front cover and remove the label.

※Display goes back when the label is removed.
 ※Label feeds by pressing flashing yellow.



RETURN

0414-0000

PACKING CONTROL PART

THE BACK WRING MOTOR ERROR

《REMOVE THE FILM AND LABEL》

- 1) Press EMERGENCY switch, REMOVE item on lift and infeed conveyor.
- 2) Open the front cover and remove the label.

※Display goes back when the label is removed.
 ※Label feeds by pressing flashing yellow.



RETURN

0415-0000

PACKING CONTROL PART

THE LEFT AND RIGHT WRING MOTOR ERROR

《REMOVE THE FILM AND LABEL》

- 1) Press EMERGENCY switch, REMOVE item on lift and infeed conveyor.
- 2) Open the front cover and remove the label.

※Display goes back when the label is removed.
 ※Label feeds by pressing flashing yellow.

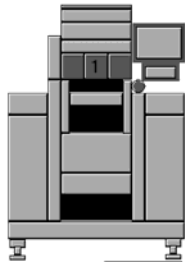

RETURN

0416-0000

PACKING CONTROL PART

THE OUTFEED PUSHER MOTOR ERROR

《REMOVE THE FILM AND LABEL》

- 1) Press EMERGENCY switch, REMOVE item on lift and infeed conveyor.
- 2) Open the front cover and remove the label.

※Display goes back when the label is removed.
 ※Label feeds by pressing flashing yellow.

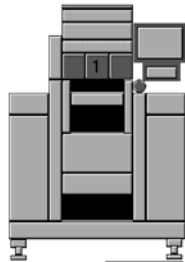

RETURN

0417-0000

PACKING CONTROL PART

THE FEEDER MOTOR ERROR

《REMOVE THE FILM AND LABEL》

- 1) Press EMERGENCY switch, REMOVE item on lift and infeed conveyor.
- 2) Open the front cover and remove the label.

※Display goes back when the label is removed.
 ※Label feeds by pressing flashing yellow.

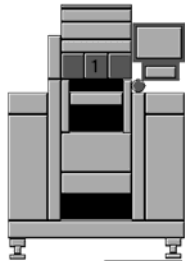

RETURN

0418-0000

PACKING CONTROL PART

THE BACK FEEDER MOVEMENT MOTOR ERROR

《REMOVE THE FILM AND LABEL》

- 1) Press EMERGENCY switch, REMOVE item on lift and infeed conveyor.
- 2) Open the front cover and remove the label.

※Display goes back when the label is removed.
 ※Label feeds by pressing flashing yellow.

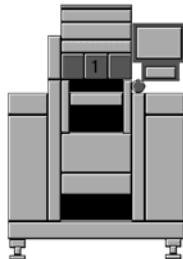

0420-0000

RETURN

PACKING CONTROL PART

INFEED MOTOR ERROR

《REMOVE THE FILM AND LABEL》

- 1) Press EMERGENCY switch, REMOVE item on lift and infeed conveyor.
- 2) Open the front cover and remove the label.

※Display goes back when the label is removed.
 ※Label feeds by pressing flashing yellow.



0421-0000

RETURN

PACKING CONTROL PART

THE LIFT CHANGE MOTOR ERROR

《REMOVE THE FILM AND LABEL》

- 1) Press EMERGENCY switch, REMOVE item on lift and infeed conveyor.
- 2) Open the front cover and remove the label.

※Display goes back when the label is removed.
 ※Label feeds by pressing flashing yellow.

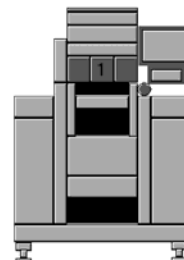

0423-0000

RETURN

PACKING CONTROL PART

THE OUTFEED CONVEYER MOTOR ERROR

《REMOVE THE FILM AND LABEL》

- 1) Press EMERGENCY switch, REMOVE item on lift and infeed conveyor.
- 2) Open the front cover and remove the label.

※Display goes back when the label is removed.
 ※Label feeds by pressing flashing yellow.

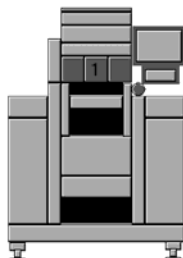

0424-0000

RETURN

PACKING CONTROL PART

THE SERVO CONTROLLER ERROR

《REMOVE THE FILM AND LABEL》

- 1) Press EMERGENCY switch, REMOVE item on lift and infeed conveyor.
- 2) Open the front cover and remove the label.

※Display goes back when the label is removed.
 ※Label feeds by pressing flashing yellow.

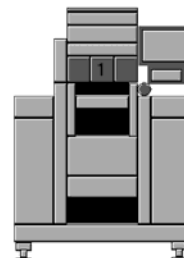

0430-0000

RETURN

PACKING CONTROL PART

THE LIFT ARRIVED AT THE MAXIMUM LIMIT

※Need not to reset the upper limit of printer

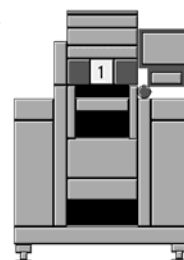

0432-0000

RETURN

PACKING CONTROL PART

A FOREIGN SUBSTANCE IS BIT UNDER LIFT

1) Move up the lift by pressing [LIFT FEED].
 2) Turn off the power and remove the foreign object.

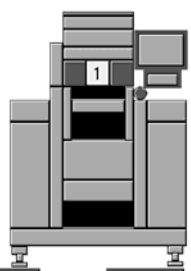

RETURN LIFT FEED

0434-0000

PACKING CONTROL PART

THE EMERGENCY STOP SWITCH WAS PUSHED

«REMOVE THE FILM AND LABEL»
 1) Press EMERGENCY switch, REMOVE item on lift and infeed conveyor.
 2) Open the front cover and remove the label.

※Display goes back when the label is removed.
 ※Label feeds by pressing flashing yellow.

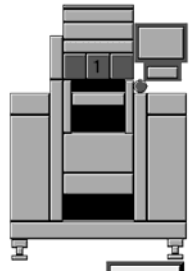

RETURN

0440-0000

PACKING CONTROL PART

THE RIGHT FILM REMOVAL DOOR WAS OPENED

«REMOVE THE FILM AND LABEL»
 1) Press EMERGENCY switch, REMOVE item on lift and infeed conveyor.
 2) Open the front cover and remove the label.

※Display goes back when the label is removed.
 ※Label feeds by pressing flashing yellow.

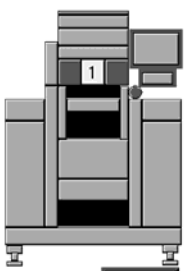

RETURN

0441-0000

PACKING CONTROL PART

THE LEFT FILM REMOVAL DOOR WAS OPENED

«REMOVE THE FILM AND LABEL»
 1) Press EMERGENCY switch, REMOVE item on lift and infeed conveyor.
 2) Open the front cover and remove the label.

※Display goes back when the label is removed.
 ※Label feeds by pressing flashing yellow.

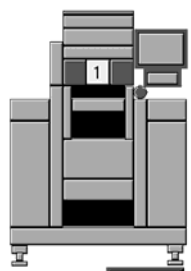

RETURN

0442-0000

PACKING CONTROL PART

FILM COVER IS OPENED

«REMOVE THE FILM AND LABEL»
 1) Press EMERGENCY switch, REMOVE item on lift and infeed conveyor.
 2) Open the front cover and remove the label.

※Display goes back when the label is removed.
 ※Label feeds by pressing flashing yellow.

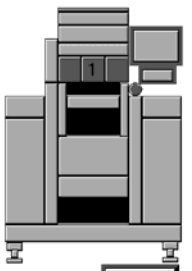

RETURN

0443-0000

PACKING CONTROL PART

THE LEFT FILM EXCHANGE DOOR WAS OPENED

«REMOVE THE FILM AND LABEL»
 1) Press EMERGENCY switch, REMOVE item on lift and infeed conveyor.
 2) Open the front cover and remove the label.

※Display goes back when the label is removed.
 ※Label feeds by pressing flashing yellow.

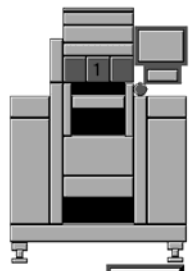

RETURN

0444-0000

PACKING CONTROL PART

THE FRONT COVER WAS OPENED

《REMOVE THE FILM AND LABEL》

- 1) Press **EMERGENCY switch**, REMOVE item on lift and infeed conveyor.
- 2) Open the front cover and remove the label.

※Display goes back when the label is removed.
 ※Label feeds by pressing flashing yellow.

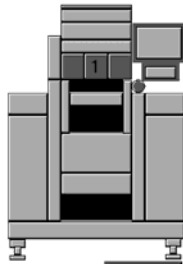

0445-0000

RETURN

PACKING CONTROL PART

THE INFEED LOWER COVER WAS OPENED

《REMOVE THE FILM AND LABEL》

- 1) Press **EMERGENCY switch**, REMOVE item on lift and infeed conveyor.
- 2) Open the front cover and remove the label.

※Display goes back when the label is removed.
 ※Label feeds by pressing flashing yellow.

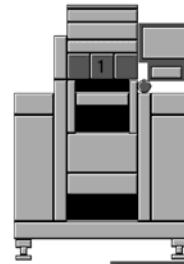

0446-0000

RETURN

PACKING CONTROL PART

INFEED COVER IS OPENED

《REMOVE THE FILM AND LABEL》

- 1) Press **EMERGENCY switch**, REMOVE item on lift and infeed conveyor.
- 2) Open the front cover and remove the label.

※Display goes back when the label is removed.
 ※Label feeds by pressing flashing yellow.

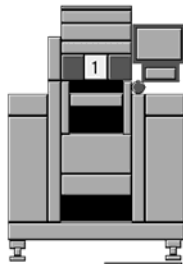

0447-0000

RETURN

PACKING CONTROL PART

DO NOT PUT HAND INTO THE WRAPPER

※Do not insert your hand into the infeed.

《REMOVE THE FILM AND LABEL》

- 1) Press **EMERGENCY switch**, REMOVE item on lift and infeed conveyor.
- 2) Open the front cover and remove the label.

※Display goes back when the label is removed.
 ※Label feeds by pressing flashing yellow.

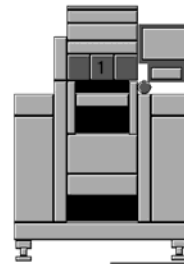

0448-0000

RETURN

PACKING CONTROL PART

DO NOT PUT HAND INTO THE WRAPPER

※Do not insert your hand into the outfeed.

《REMOVE THE FILM AND LABEL》

- 1) Press **EMERGENCY switch**, REMOVE item on lift and infeed conveyor.
- 2) Open the front cover and remove the label.

※Display goes back when the label is removed.
 ※Label feeds by pressing flashing yellow.

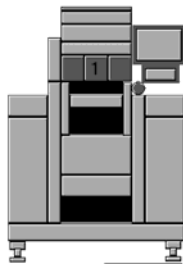

0449-0000

RETURN

PACKING CONTROL PART

THE OUTFEED HAS PULLED UP

《REMOVE THE FILM AND LABEL》

- 1) Press **EMERGENCY switch**, REMOVE item on lift and infeed conveyor.
- 2) Open the front cover and remove the label.

※Display goes back when the label is removed.
 ※Label feeds by pressing flashing yellow.

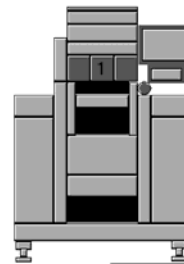

0450-0000

RETURN

PACKING CONTROL PART

ITEMS WERE NOT THROWN IN

《REMOVE THE FILM AND LABEL》

- 1) Press **EMERGENCY switch**, REMOVE item on lift and infeed conveyor.
- 2) Open the front cover and remove the label.

※Display goes back when the label is removed.
 ※Label feeds by pressing flashing yellow.

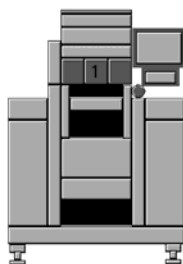

0460-0000

RETURN

PACKING CONTROL PART

THE RIGHT-HAND SIDE FILM OVER ERROR

《REMOVE THE FILM AND LABEL》

- 1) Press **EMERGENCY switch**, REMOVE item on lift and infeed conveyor.
- 2) Open the front cover and remove the label.

※Display goes back when the label is removed.
 ※Label feeds by pressing flashing yellow.

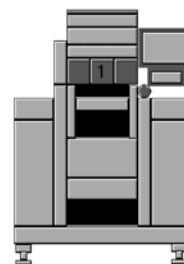

0461-0000

RETURN

PACKING CONTROL PART

THE LEFT-HAND SIDE FILM OVER ERROR

《REMOVE THE FILM AND LABEL》

- 1) Press **EMERGENCY switch**, REMOVE item on lift and infeed conveyor.
- 2) Open the front cover and remove the label.

※Display goes back when the label is removed.
 ※Label feeds by pressing flashing yellow.

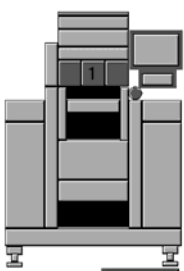

0462-0000 RETURN

PACKING CONTROL PART

THE RIGHT-HAND SIDE FILM WAS LOST

※Check the right film.

《REMOVE THE FILM AND LABEL》

- 1) Press **EMERGENCY switch**, REMOVE item on lift and infeed conveyor.
- 2) Open the front cover and remove the label.

※Display goes back when the label is removed.
 ※Label feeds by pressing flashing yellow.

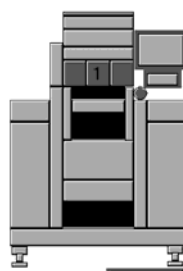

0463-0000 RETURN

PACKING CONTROL PART

THE LEFT-HAND SIDE FILM WAS LOST

※Check the left film.

《REMOVE THE FILM AND LABEL》

- 1) Press **EMERGENCY switch**, REMOVE item on lift and infeed conveyor.
- 2) Open the front cover and remove the label.

※Display goes back when the label is removed.
 ※Label feeds by pressing flashing yellow.

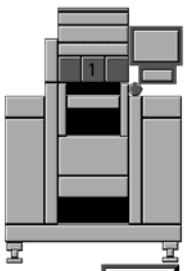

0464-0000 RETURN

OFFLINE PLU No. 000000 STORE 24.MAY.2005(TUE) 6:52 MENU

PACKING CONTROL PART

THE PROBLEM AROSE IN THE WRAPPER

※Release should reswitch on the power after shutting off the power supply and waiting for 10 seconds.
 ※The control board of wrapper is abnormal.

0471-0000

DIAL ADJUST ADD IN-FEED SPD(H) WRAP SPD (HIGH) WRAPPING ADJUST TRAY AUTO CALCULAT

OFFLINE PLU No. 000000 STORE 24.MAY.2005(TUE) 6:58 MENU

PACKING CONTROL PART

THE PROBLEM AROSE IN THE WRAPPER

※Release should reswitch on the power after shutting off the power supply and waiting for 10 seconds.
 ※Wiring control board is in malfunction.

0472-0000

DIAL ADJUST ADD IN-FEED SPD(H) WRAP SPD (HIGH) WRAPPING ADJUST TRAY AUTO CALCULAT

PACKING CONTROL PART

THE PROBLEM AROSE AT SEAL HEATER

※Front outfeed heater is abnormal.
 ※Front outfeed heater is out of use.

《REMOVE THE FILM AND LABEL》

- 1) Press **EMERGENCY switch**, REMOVE item on lift and infeed conveyor.
- 2) Open the front cover and remove the label.

※Display goes back when the label is removed.
 ※Label feeds by pressing flashing yellow.

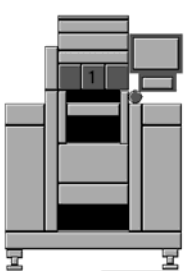

0473-0000 RETURN

PACKING CONTROL PART

THE PROBLEM AROSE AT SEAL HEATER

※Back outfeed heater is abnormal.
 ※Back outfeed heater is out of use.

《REMOVE THE FILM AND LABEL》

- 1) Press **EMERGENCY switch**, REMOVE item on lift and infeed conveyor.
- 2) Open the front cover and remove the label.

※Display goes back when the label is removed.
 ※Label feeds by pressing flashing yellow.

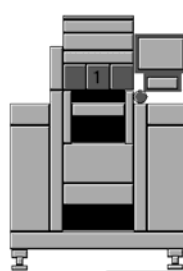

0474-0000 RETURN

PACKING CONTROL PART

THE LIFT CONTACTS THE FEEDER

#The stretch is not enough.
 <<REMOVE THE FILM AND LABEL>>

- 1) Press **EMERGENCY switch**, REMOVE item on lift and infeed conveyor.
- 2) Open the front cover and remove the label.

#Display goes back when the label is removed.
 #Label feeds by pressing flashing yellow.

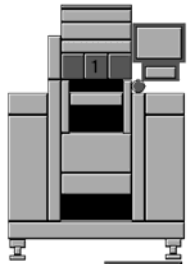

RETURN

0475-0000

PACKING CONTROL PART

INJECTION TRAY DIFFERS FROM SETTING

#Check tray and tray no.
 <<REMOVE THE FILM AND LABEL>>

- 1) Press **EMERGENCY switch**, REMOVE item on lift and infeed conveyor.
- 2) Open the front cover and remove the label.

#Display goes back when the label is removed.
 #Label feeds by pressing flashing yellow.

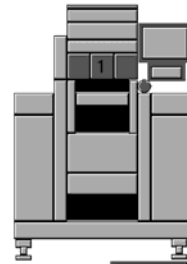

RETURN

0476-0000

PACKING CONTROL PART

THE LEFT PLUG OPENING/CLOSING ARE NOT SET

#Open the left film exchange cover, set the insertion plate.
 <<REMOVE THE FILM AND LABEL>>

- 1) Press **EMERGENCY switch**, REMOVE item on lift and infeed conveyor.
- 2) Open the front cover and remove the label.

#Display goes back when the label is removed.
 #Label feeds by pressing flashing yellow.

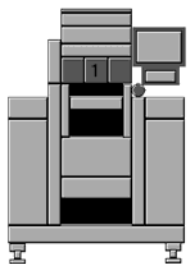

RETURN

0479-0000

PACKING CONTROL PART

THE S CUTTER HAS NOT RETURNED

#Open film release cover (Right side) & check if there is any foreign object at cutter.
 <<REMOVE THE FILM AND LABEL>>

- 1) Press **EMERGENCY switch**, REMOVE item on lift and infeed conveyor.
- 2) Open the front cover and remove the label.

#Display goes back when the label is removed.
 #Label feeds by pressing flashing yellow.

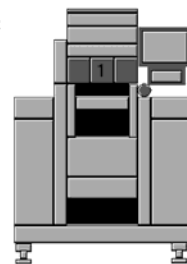

RETURN

0481-0000

14.5 ERROR CODE (0600 -)

LABELING MACHINE CONTROL PART

THE APPLICATOR WAS NOT CONNECTED

#Confirm the connection with the applicator.
 1) Press [RE-TRY] key.
 2) Press [OK] key if error is not cleared.
 3) In this case, Operation with labeling nothing is possible.

0601-0000

OK RE-TRY

LABELING MACHINE CONTROL PART

THERE IS NO RESPONSE FROM THE APPLICATOR

#Confirm the connection with the applicator.
 1) Press [RE-TRY] key.
 2) Press [OK] key if error is not cleared.
 3) In this case, Operation with labeling nothing is possible.

0602-0000

OK RE-TRY

LABELING MACHINE CONTROL PART

THE PROBLEM AROSE IN THE APPLICATOR

#Release should reswitch on the power after shutting off the power supply and waiting for 10 seconds.
 #Send command and Receive command does not match.

0603-0000

LABELING MACHINE CONTROL PART

THE INSTANT POWER FAILURE OCCURRED BY THE CONSOLE

#Release should reswitch on the power after shutting off the power supply and waiting for 10 seconds.

0604-0000

LABELING MACHINE CONTROL PART

THE INSTANT POWER FAILURE WAS DETECTED WITH APPLICATOR

#Release should reswitch on the power after shutting off the power supply and waiting for 10 seconds.

0605-0000

LABELING MACHINE CONTROL PART

THE PROBLEM AROSE IN THE APPLICATOR

#Confirm the connection with the applicator.
 #Proceed the setup for applicator.
 #Press [OK] to operate without applicator.

0606-0000

OK

LABELING MACHINE CONTROL PART

THE PROBLEM AROSE IN THE APPLICATOR

#Confirm the applicator.
 #The sum value does not match.
 #Proceed the setup for applicator.
 #Press [OK] to operate without applicator.

0607-0000

OK

LABELING MACHINE CONTROL PART

OPERATION OF THE APPLICATOR STOPPED

《REMOVE THE FILM AND LABEL》
 1) Press EMERGENCY switch, REMOVE item on lift and infeed conveyer.
 2) Open the front cover and remove the label.

#Display goes back when the label is removed.
 #Label feeds by pressing flashing yellow.

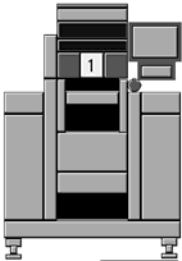

0608-0000

RETURN

LABELING MACHINE CONTROL PART

ADSORPTION OF LABEL WAS NOT COMPLETED

#Press [PLU] key to outfeed the tray.
 #Proceed the following procedure to return.
 <<REMOVE THE FILM AND LABEL>>
 1) Press EMERGENCY switch, REMOVE item on lift and infeed conveyor.
 2) Open the front cover and remove the label.

#Display goes back when the label is removed.
 #Label feeds by pressing flashing yellow.

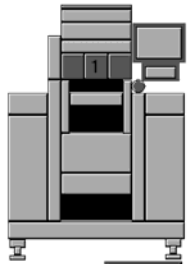

RETURN

0609-0000

LABELING MACHINE CONTROL PART

THERE IS NO LABEL ATTACHMENT

#Press [PLU] key to outfeed the tray.
 #Proceed the following procedure to return.
 <<REMOVE THE FILM AND LABEL>>
 1) Press EMERGENCY switch, REMOVE item on lift and infeed conveyor.
 2) Open the front cover and remove the label.

#Display goes back when the label is removed.
 #Label feeds by pressing flashing yellow.

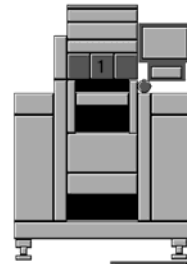

RETURN

0610-0000

LABELING MACHINE CONTROL PART

A LABEL WAS NOT ABLE TO BE STUCK

#Press [PLU] key to outfeed the tray.
 #Proceed the following procedure to return.
 <<REMOVE THE FILM AND LABEL>>
 1) Press EMERGENCY switch, REMOVE item on lift and infeed conveyor.
 2) Open the front cover and remove the label.

#Display goes back when the label is removed.
 #Label feeds by pressing flashing yellow.

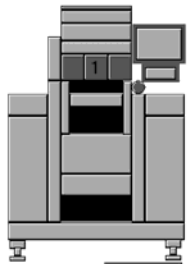

RETURN

0611-0000

LABELING MACHINE CONTROL PART

A LABEL WAS NOT ABLE TO BE STUCK

#Press [PLU] key to outfeed the tray.
 #Proceed the following procedure to return.
 <<REMOVE THE FILM AND LABEL>>
 1) Press EMERGENCY switch, REMOVE item on lift and infeed conveyor.
 2) Open the front cover and remove the label.

#Display goes back when the label is removed.
 #Label feeds by pressing flashing yellow.



RETURN

0612-0000

LABELING MACHINE CONTROL PART

THE LABEL REMAINS IN THE APPLICATOR

#Open the front cover, take the label from applicator, place the label on the tray.
 #Press [PLU] key to outfeed the tray.
 #Proceed the following procedure to return.
 <<REMOVE THE FILM AND LABEL>>
 1) Press EMERGENCY switch, REMOVE item on lift and infeed conveyor.
 2) Open the front cover and remove the label.

#Display goes back when the label is removed.



RETURN

0613-0000

LABELING MACHINE CONTROL PART

DO NOT PUT A HAND INTO A FRONT COVER

#Press [PLU] key to outfeed the tray.
 #Proceed the following procedure to return.
 <<REMOVE THE FILM AND LABEL>>
 1) Press EMERGENCY switch, REMOVE item on lift and infeed conveyor.
 2) Open the front cover and remove the label.

#Display goes back when the label is removed.
 #Label feeds by pressing flashing yellow.

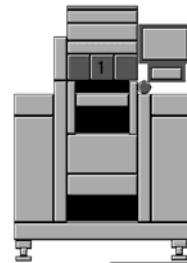

RETURN

0614-0000

LABELING MACHINE CONTROL PART

ABNORMAL ERROR IN THE APPLICATOR OPERATE

#Press [PLU] key to outfeed the tray.
 #Proceed the following procedure to return.
 <<REMOVE THE FILM AND LABEL>>
 1) Press EMERGENCY switch, REMOVE item on lift and infeed conveyor.
 2) Open the front cover and remove the label.

#Display goes back when the label is removed.
 #Label feeds by pressing flashing yellow.



RETURN

0615-0000

LABELING MACHINE CONTROL PART

THE SENSOR OF THE APPLICATOR IS UNUSUAL

<<REMOVE THE FILM AND LABEL>>
 1) Press EMERGENCY switch, REMOVE item on lift and infeed conveyor.
 2) Open the front cover and remove the label.

#Display goes back when the label is removed.
 #Label feeds by pressing flashing yellow.

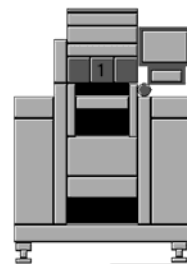

RETURN

0616-0000

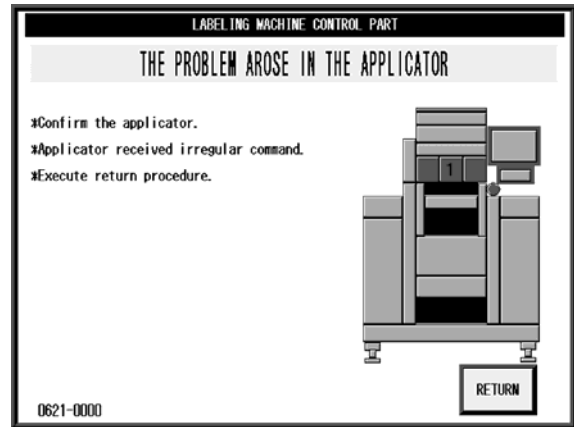

14.6 ERROR CODE (0700 -)

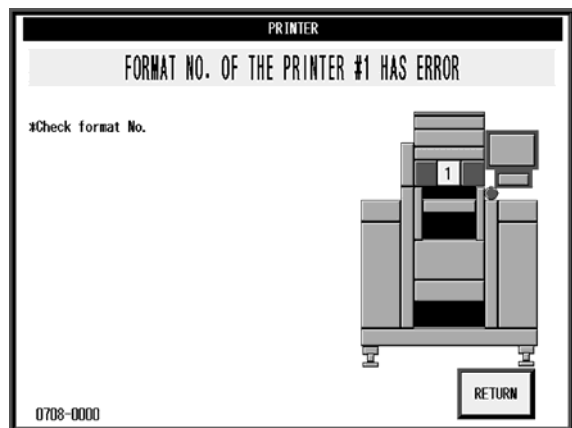
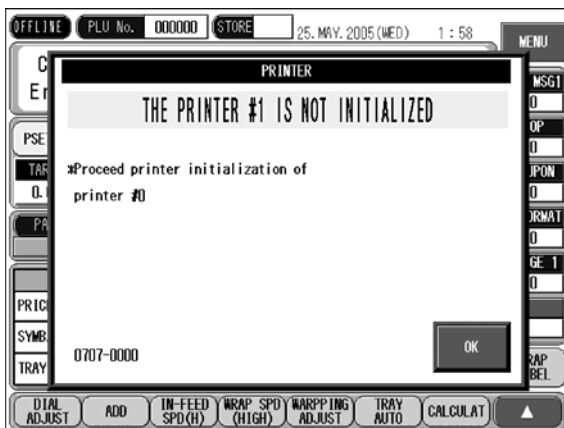
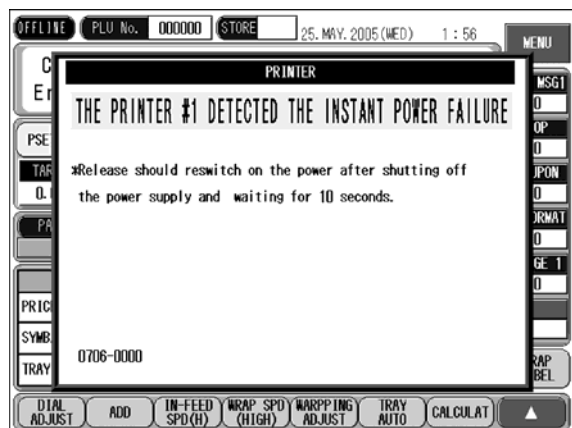
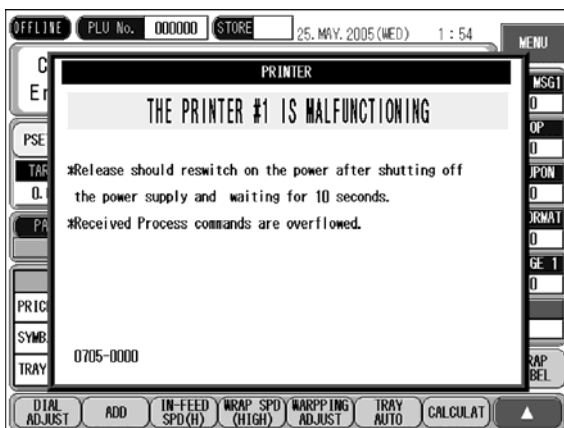
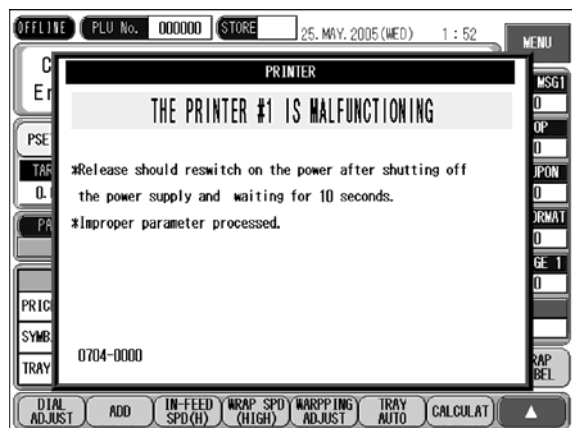
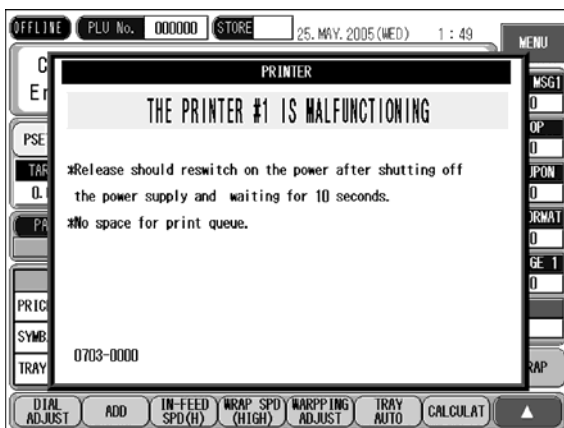
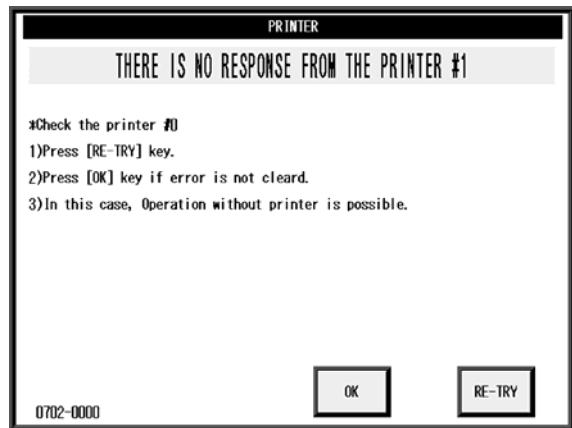
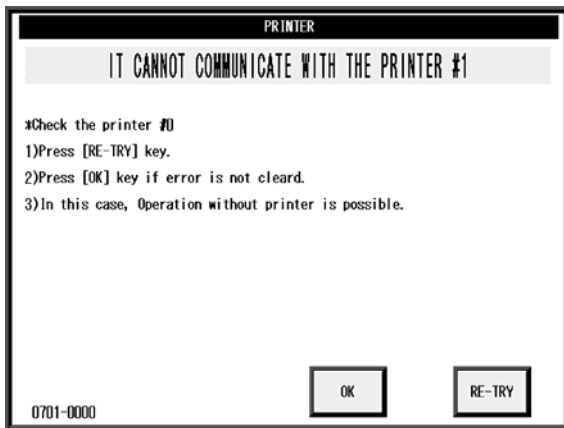

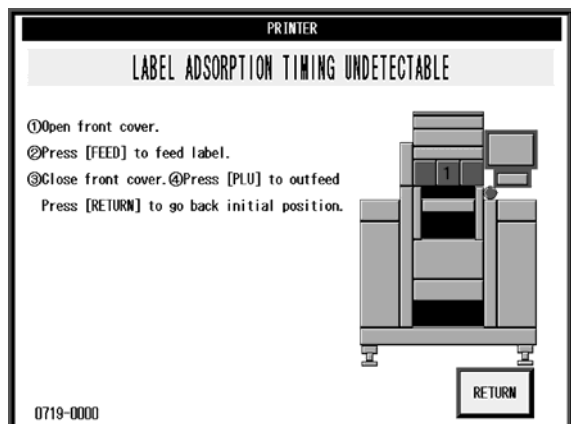
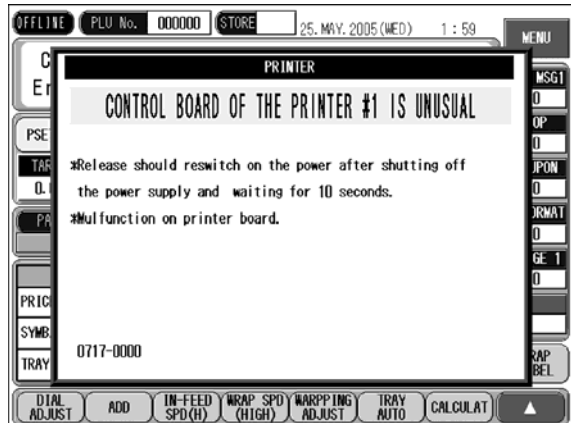
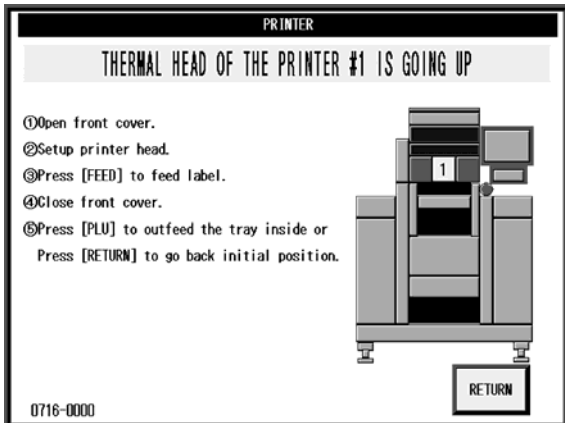
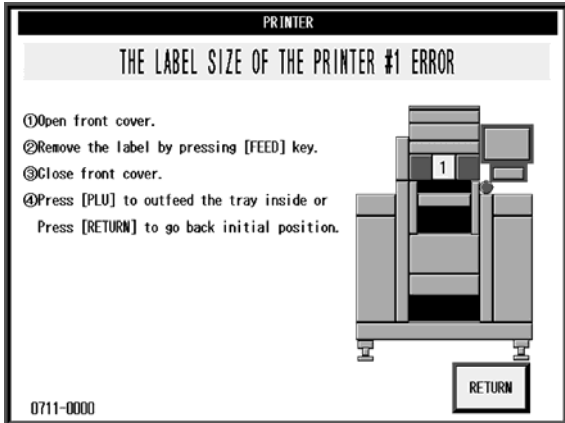
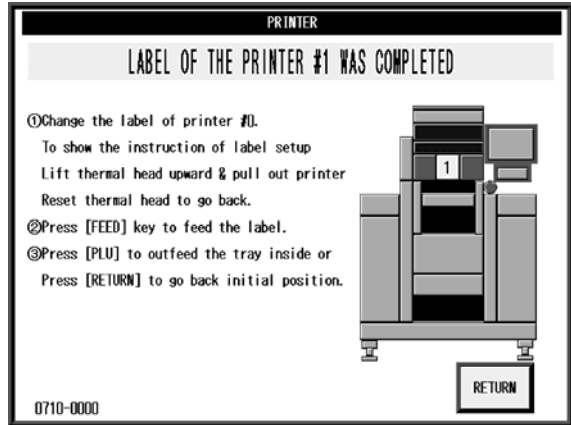

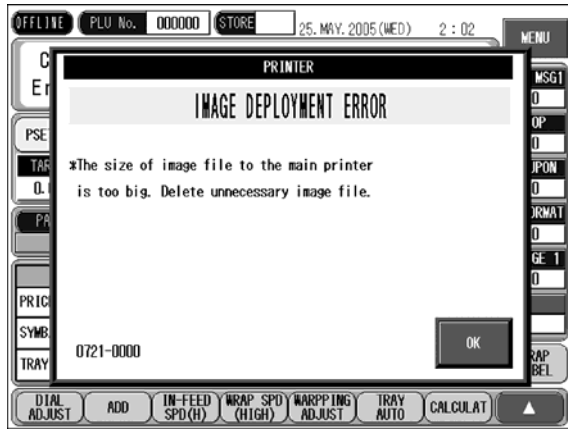

14.7 ERROR CODE (0800 -)

14.8 ERROR CODE (1300 -)

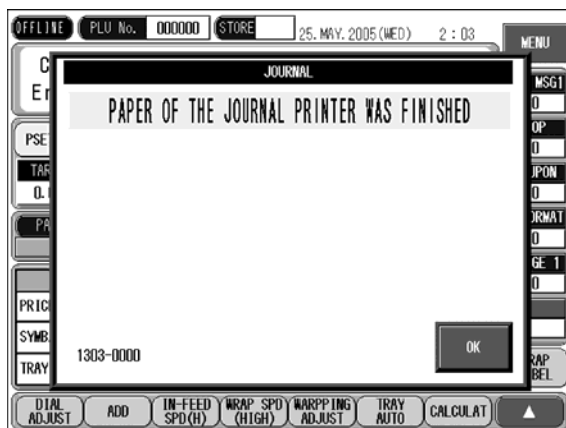
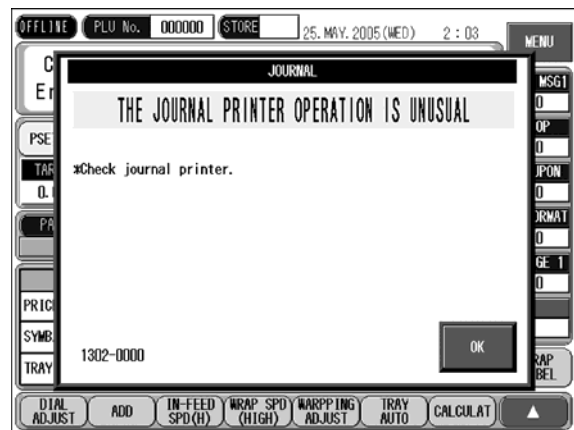
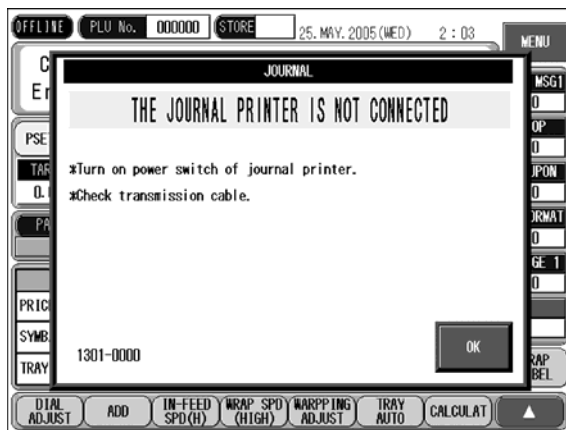

14.9 ERROR CODE (1400 -)

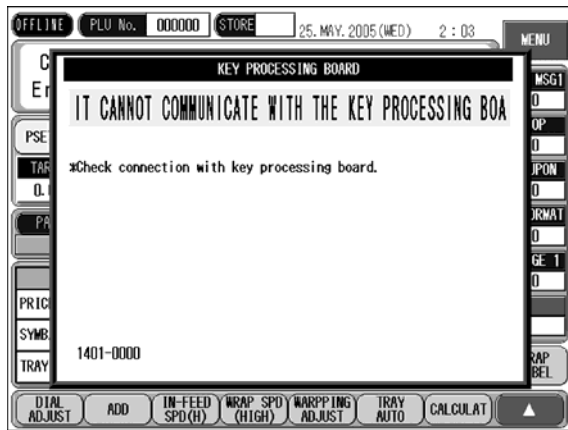

14.10 ERROR CODE (1500 -)

14.11 ERROR CODE (1600 -)

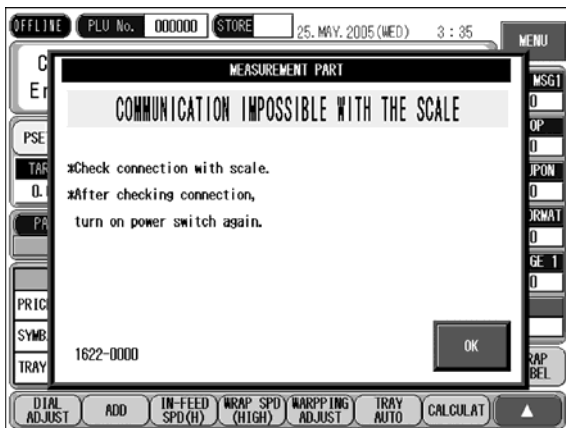
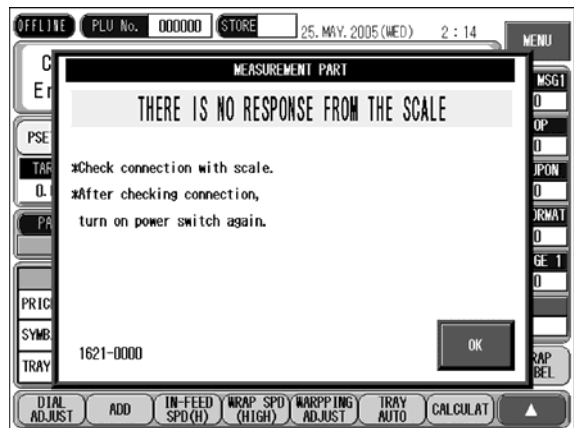
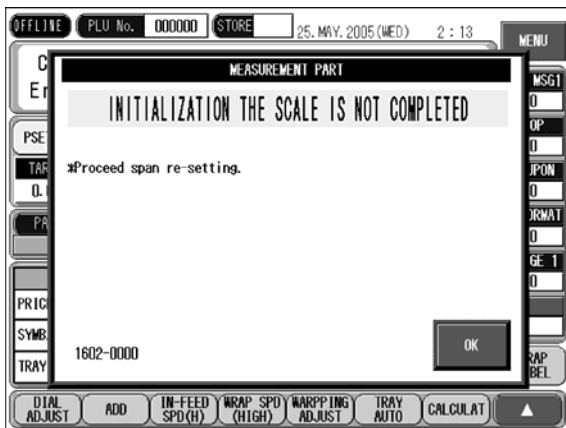
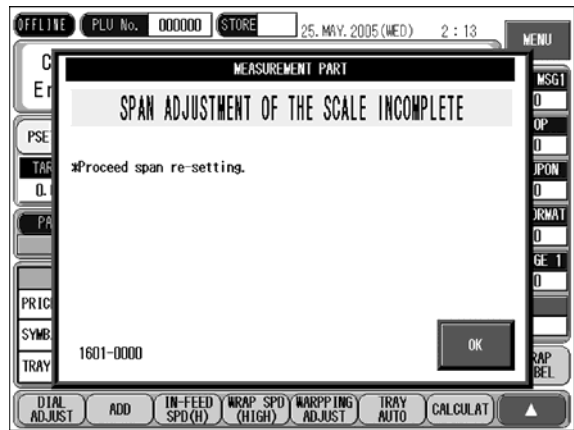
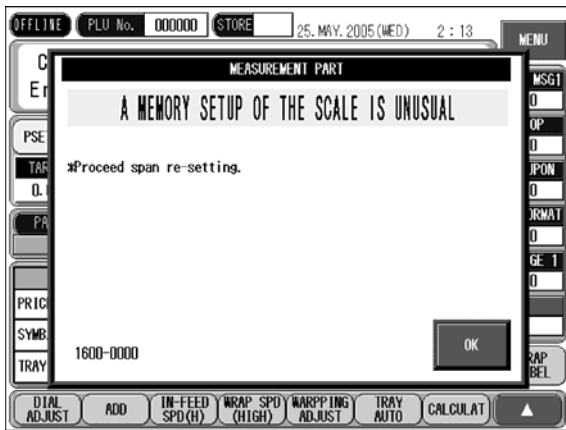

14.12 ERROR CODE (2000 -)

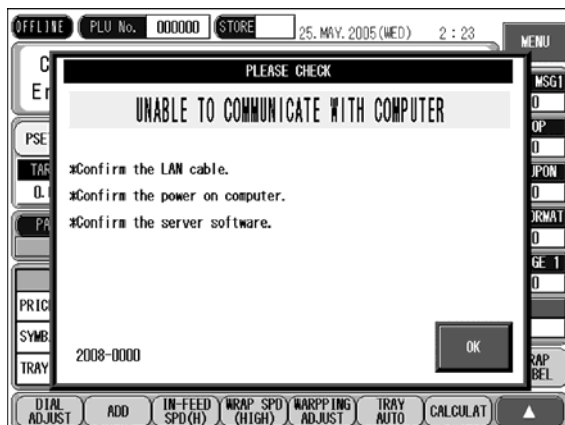
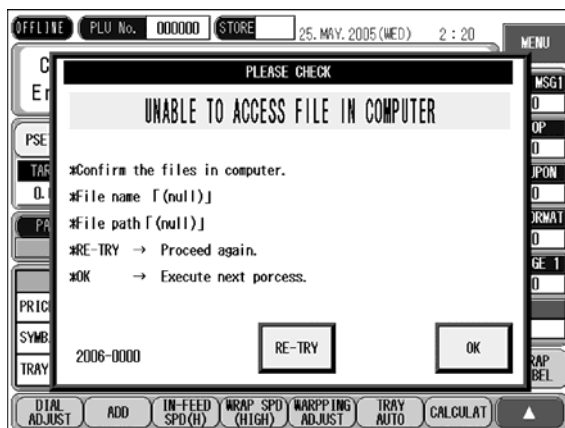
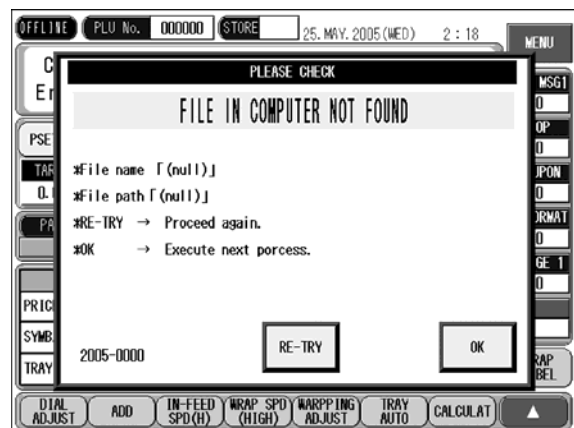
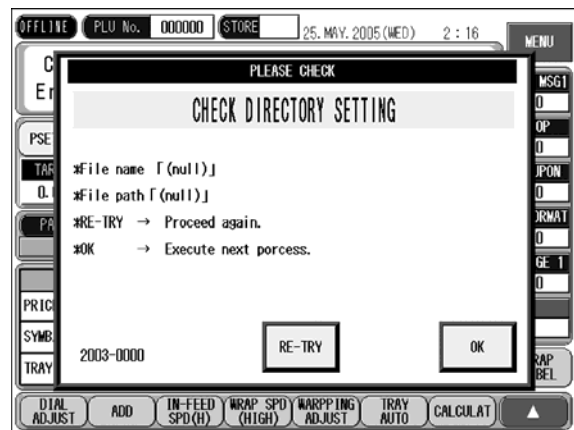
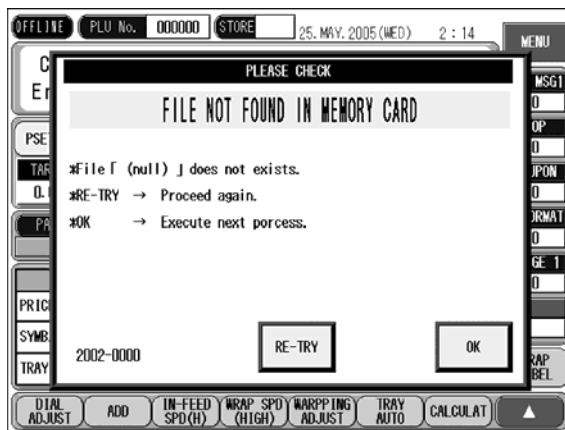

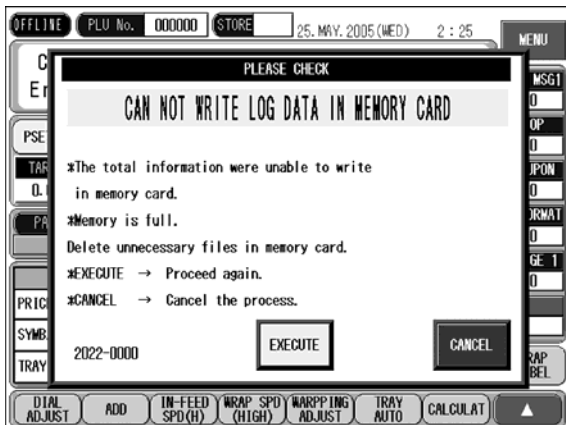
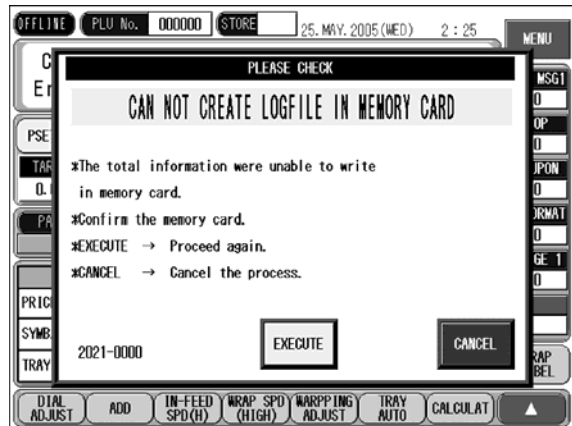
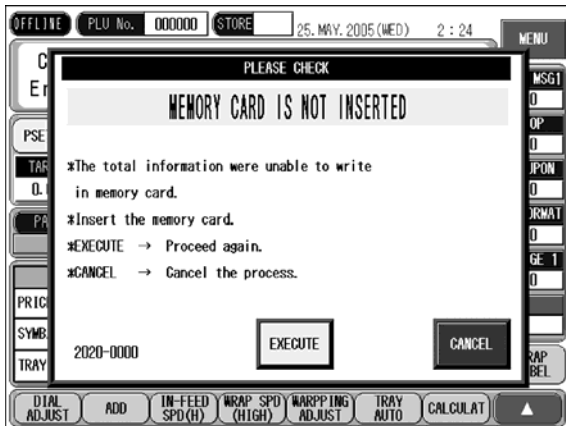

14.13 ERROR CODE (9000 -)

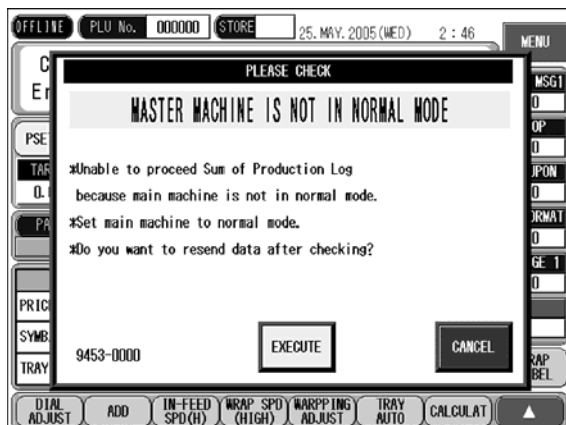
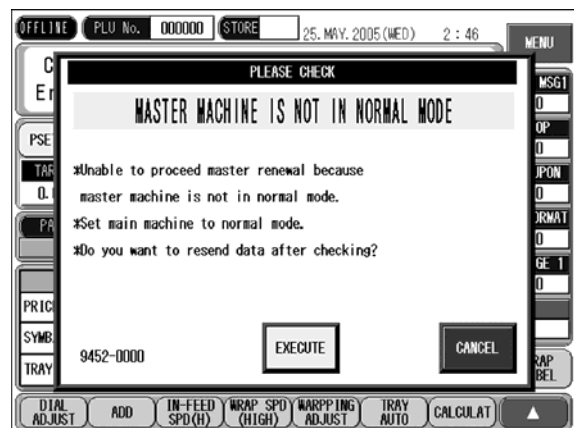
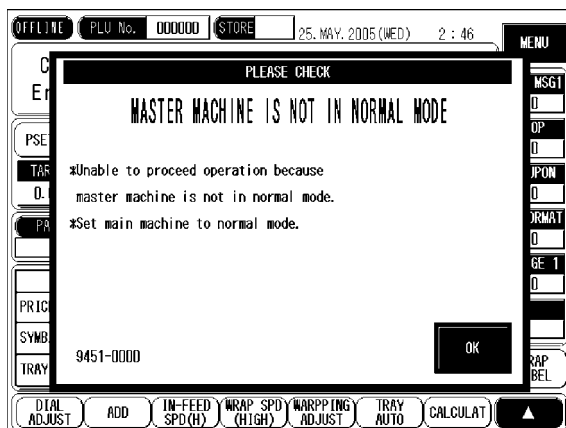
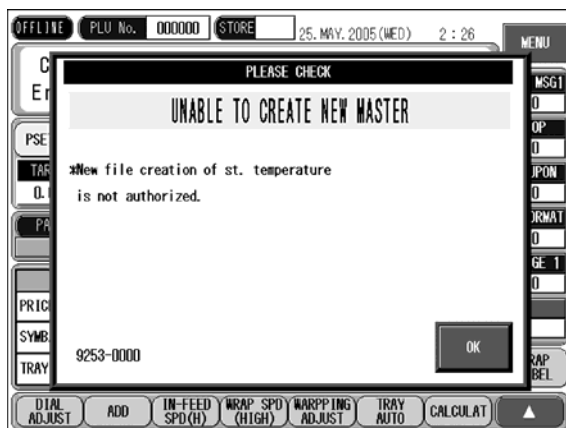

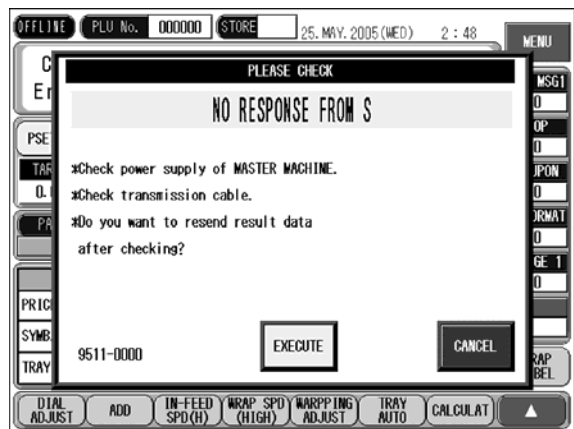
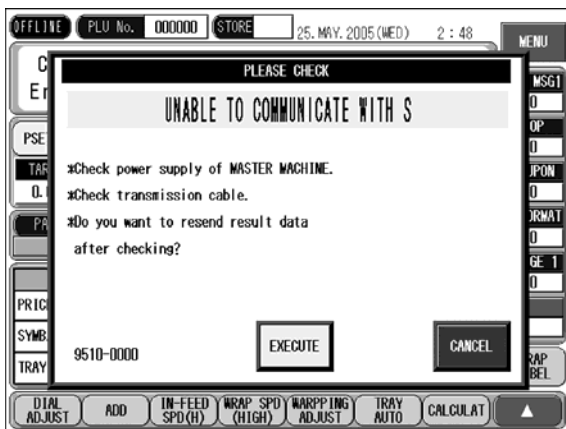
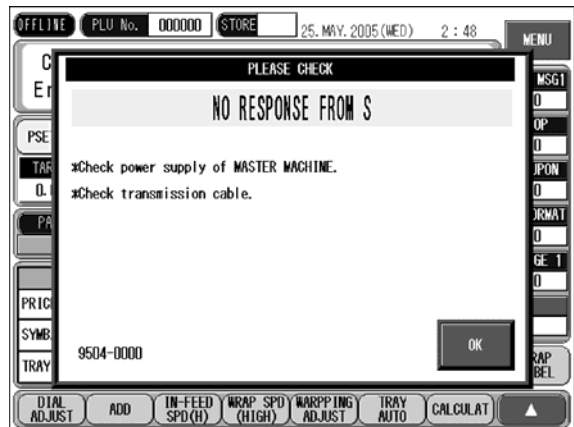
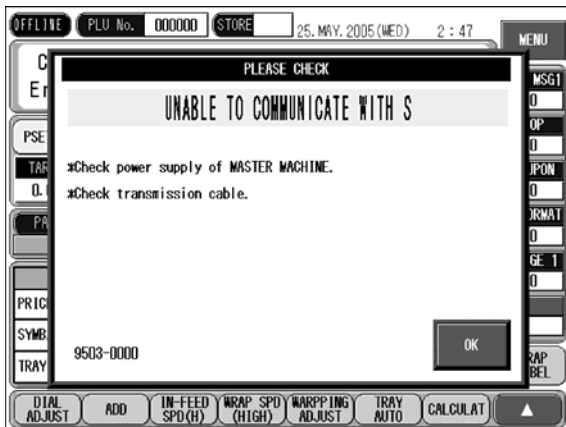
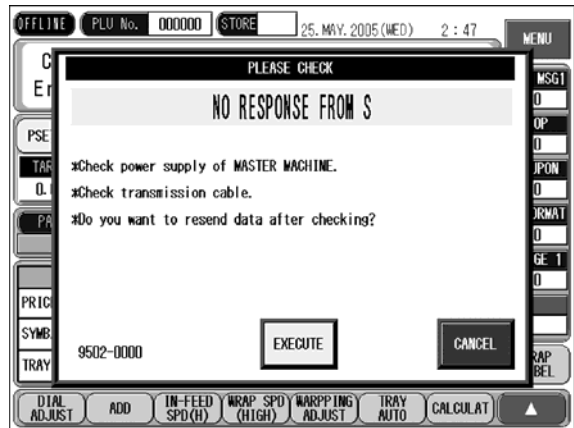
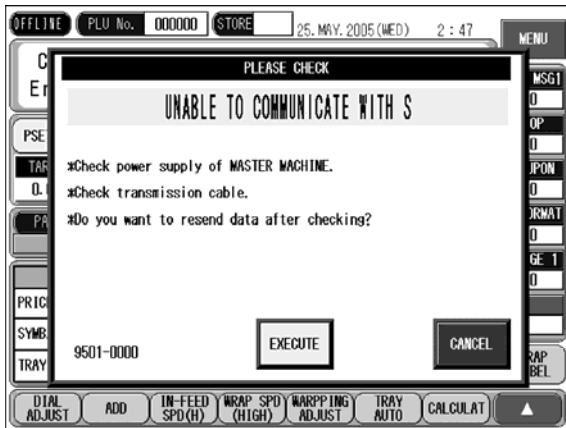
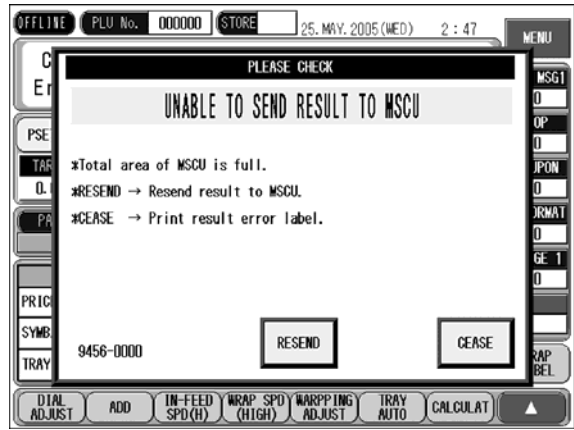
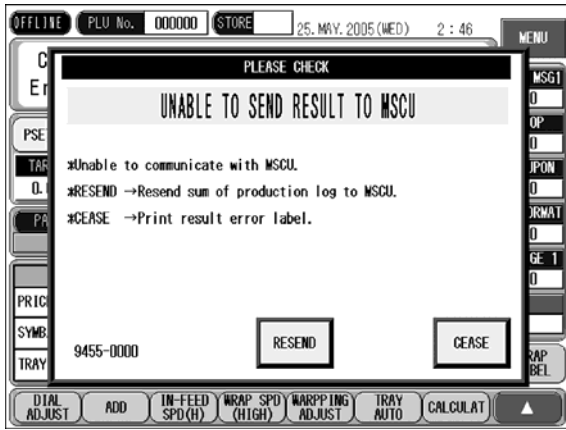

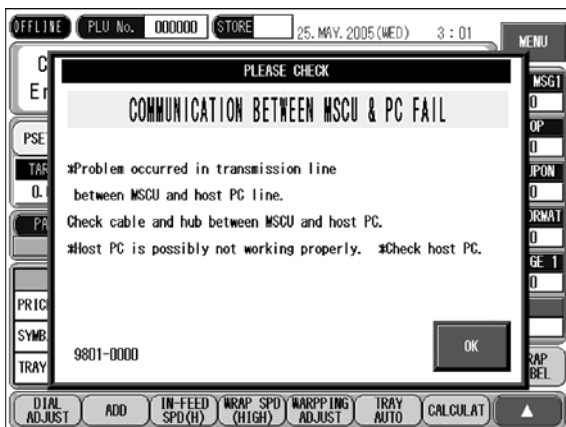
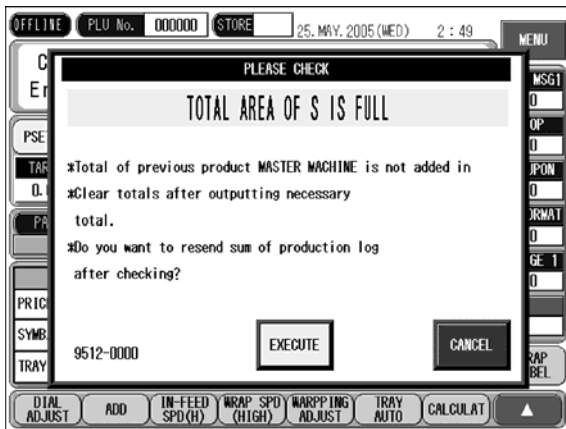

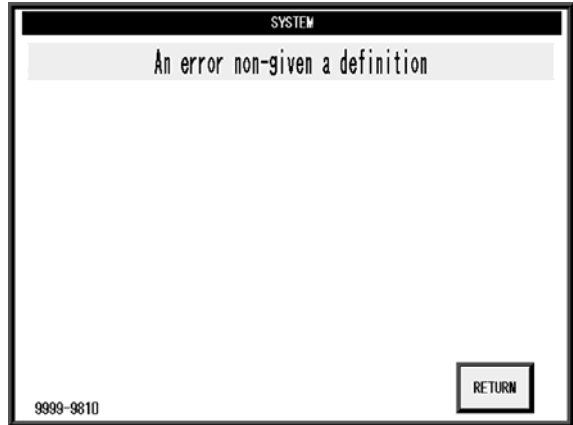
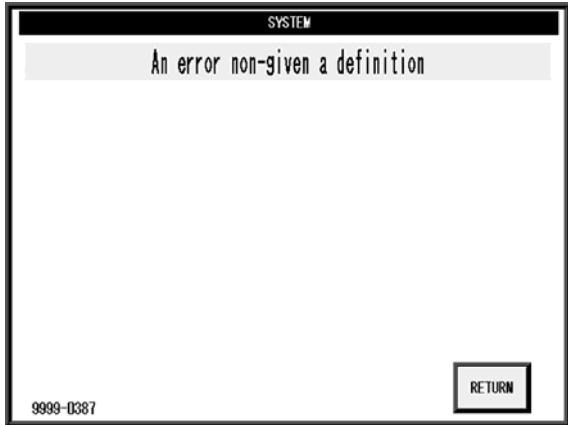
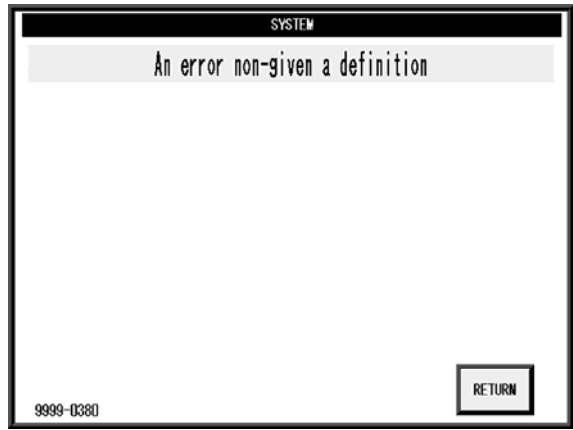
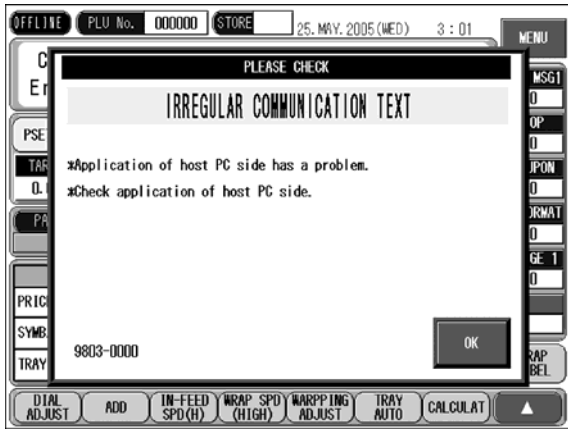

15

ERROR CODES AND TROUBLESHOOTING

CONTENTS

15.1	ERROR CODE (0100 -).....	15-2
15.2	ERROR CODE (0200 -).....	15-3
15.3	ERROR CODE (0300 -).....	15-6
15.4	ERROR CODE (0400 -).....	15-10
15.5	ERROR CODE (0600 -).....	15-20
15.6	ERROR CODE (0700 -).....	15-24
15.7	ERROR CODE (1400 -).....	15-27
15.8	ERROR CODE (1600 -).....	15-28

Chapter 15 Error Codes and Troubleshooting

15.1 ERROR CODE (0100 -)

No.	Message	Symptom or Phenomenon	Response or Check
101	"SYSTEM MALFUNCTION"	Does not occur during normal operation.	Restore power. P-910 or programCF
102	"SEQUENCE MALFUNCTION"	The peripheral devices are controlled by assigning each cycle a sequence number. These are inconsistent.	Restore power. Does not occur during normal operation.
103	"IRREGULAR PRINTER NO."	Attempting to send a message to a non-existent printer.	Restore power. Does not occur during normal operation.
104	"NETWORK IS RE-SETTING"	Network settings have been lost. Restarts automatically	The device will automatically restart. Please wait a moment.
105	"MEMORY INITIALIZATION IS OK"	Can only enter test mode and system mode. Initialization of P-910 memory has not been performed.	Initialize P-910 memory in test mode.
106	"BATTERY IS DEFECTIVE"	Can only enter test mode and system mode. P-910 battery switch is OFF or burnt out.	1. Confirm switch is in the ON position, switch ON. 2. If the battery is ON, the battery is exhausted. Replace P-910 main board.
107	"TOUCH PANEL ADJUSTMENT IS INCOMPLETE"	Can only enter test mode and system mode.	Perform touch panel adjustment on adjustment screen
108	"TIME SETTING IS INCOMPLETE"	Can only enter test mode and system mode.	Set clock.
109	"PRINTER No.S INITIALIZATE IS INCOMPLETE"	Can only enter test mode and system mode. Printer initialization is incomplete.	In test mode, initialize printer unit memory in printer adjustment screen 1/2. (P-909*)
110	"MACHINE SETTING IS INCOMPLETE"	Can only enter test mode and system mode.	Set model settings in test mode.

Chapter 15 Error Codes and Troubleshooting

15.2 ERROR CODE (0200 -)

No.	Message	Symptom or Phenomenon	Response or Check
202	"PRODUCT MASTER IS NOT REGISTERED"	PLU No. ** is not programmed. Check PLU No.	Register the PLU on the REGISTRATION menu.
203	"POP MASTER IS NOT REGISTERED"	POP No. ** is not programmed. Delete ?	Register POP on the REGISTRATION menu. If auto updating for POP No. is set to "NO", it can not be deleted even if EXECUTE is pressed. Error display "YES/NO" can be changed by LINK MASTER error setting.
204	"ORIGIN MASTER IS NOT REGISTERED"	Country of Origin No. is not programmed. Delete?	Register the country of origin on REGISTRATION menu. If auto updating for Country of Origin No. is set to "NO", it cannot be deleted even if EXECUTE is pressed. Error display "YES/NO" can be changed by LINK MASTER error setting.
205	"EXTRA MSG 1 MASTER IS NOT REGISTERED";	Ingredient No. ** is not programmed. Delete?	Register ingredients on REGISTRATION menu. If auto updating for Ingredient No. is set to "NO", it cannot be deleted even if EXECUTE is pressed. Error display "YES/NO" can be changed by LINK MASTER error setting.
206	"EXTRA MSG 3 MASTER IS NOT REGISTERED"	Storage method No.** is not programmed. Delete?	Register the storage method on REGISTRATION menu. If auto updating for Storage Method No. is set to "NO", it cannot be deleted even if EXECUTE is pressed. Error display "YES/NO" can be changed by LINK MASTER error setting.
207	"EXTRA MSG 2 MASTER IS NOT REGISTERED"	Storage temperature No.** is not programmed. Delete?	Register the storage temperature on REGISTRATION menu. If auto updating for Storage Temp. No. is set to "NO", it cannot be deleted even if EXECUTE is pressed. Error display "YES/NO" can be changed by LINK MASTER error setting.
208	"IMAGE NO. 1 MASTER IS NOT REGISTERED"	Image No.1** is not programmed. Check Image No.1**.	If auto updating for Image No.1 is set to "NO", it cannot be deleted even if EXECUTE is pressed.
209	"IMAGE NO. 2 MASTER IS NOT REGISTERED"	Image No.2** is not programmed. Check Image No.2**.	If auto updating for Image No.2 is set to "NO", it cannot be deleted even if EXECUTE is pressed.
210	"TRAY MASTER IS NOT REGISTERED"	Tray No.** is not programmed.	Check Tray No.
212	" IS NOT REGISTERED"	** is not programmed.Delete?	Register FREE MASTER 1 on REGISTRATION menu. If auto updating for Free Master 1 is set to "NO", it cannot be deleted even if EXECUTE is pressed. Error display "YES/NO" can be changed by LINK MASTER error setting. Free Master name must be careful as it can be changed at "FREE MASTER NAME SETTING" in system mode.
213	" IS NOT REGISTERED"	** is not programmed.Delete?	Register Free Master 2 on REGISTRATION menu. If auto updating for Free Master 2 is set to "NO", it cannot be deleted even if EXECUTE is pressed. Error display "YES/NO" can be changed by LINK MASTER error setting. Free Master name must be careful as it can be changed at "FREE MASTER NAME SETTING" in system mode.

Chapter 15 Error Codes and Troubleshooting

15.2 ERROR CODE (0200 -)

No.	Message	Symptom or Phenomenon	Response or Check
214	" IS NOT REGISTERED"	** is not programmed.Delete?	Register Free Master 3 on REGISTRATION menu. If auto updating for Free Master 3 is set to "NO", it cannot be deleted even if EXECUTE is pressed. Error display "YES/NO" can be changed by LINK MASTER error setting. Free Master name must be careful as it can be changed at "FREE MASTER NAME SETTING" in system mode.
215	" IS NOT REGISTERED"	** is not programmed.Delete?	Register Free Master 4 on REGISTRATION menu. If auto updating for Free Master 4 is set to "NO", it cannot be deleted even if EXECUTE is pressed. Error display "YES/NO" can be changed by LINK MASTER error setting. Free Master name must be careful as it can be changed at "FREE MASTER NAME SETTING" in system mode.
216	" IS NOT REGISTERED"	** is not programmed.Delete?	Register Free Master 5 on REGISTRATION menu. If auto updating for Free Master 5 is set to "NO", it cannot be deleted even if EXECUTE is pressed. Error display "YES/NO" can be changed by LINK MASTER error setting. Free Master name must be careful as it can be changed at "FREE MASTER NAME SETTING" in system mode.
219	"STORE MASTER IS NOT REGISTERED"	STORE MASTER No.** is not programmed. Check Store Master.	Register STORE MASTER on REGISTRATION menu.
220	"PLU LINK MASTER IS NOT REGISTERED"		
221	"EXCEEDED MAXIMUM TARE WEIGHT (9.995lb)"	"EXCEEDED MAXIMUM TARE WEIGHT (9.995lb)"	Check and reset the tare weight. Check the weight value by the weight. Upon release of error, tare weight is cleared.
221	"EXCEEDED MAXIMUM TARE WEIGHT (9.995 lb)"	"EXCEEDED MAXIMUM TARE WEIGHT (9.995 lb)"	Check and reset the tare weight. Check the weight value by the weight. Upon release of error, tare weight is cleared.
222	"TARE WEIGHT IS SET AT 0"	Tare weight is not set yet.	Set the tare weight. If "tare no setting error" is set to "not display"(in setting mode, error menu), it will not appear as error.
223	"COMMENT MASTER IS NOT REGISTERED"	COMMENT MASTER No.** is not programmed. Delete?	Register COMMENT MASTER on REGISTRATION menu. If auto updating for comment is set to "NO", it cannot be deleted even if EXECUTE is pressed. Error display "YES/NO" can be changed by LINK MASTER error setting.
224	"LABEL MASTER IS NOT REGISTERED"	Check LABEL SETTING MASTER No.	Check the label setting in system mode. No.[***] is newly registered as the default, press EXECUTE key.

Chapter 15 Error Codes and Troubleshooting

15.2 ERROR CODE (0200 -)

No.	Message	Symptom or Phenomenon	Response or Check
225	"LABEL FORMAT IS NOT REGISTERED"	LABEL FORMAT No.** is not programmed.	The format of label format No.is not registered. Set the format or check the format No. on ITEM MASTER.
226	"INTERNAL TOTAL MEMORY IS INSUFFICIENT"	New data can no longer be stored.	Number of data is over the registrable 4000 items (commodity name;30 characters average). Delete unnecessary data and register new data. If unable to delete, clear RAM as the RAM area is damaged, or main board is faulty (P-910H-2) (Data is faulty).
227	"INTERNAL TOTAL MEMORY IS FULL"	Preceding total is not added.	Clear the total. RAM clear or faulty main board (P-910H-2 : 097-5687-**) (Faulty data)
228	"CHECK MEMORY CARD"	Memory card is not inserted.	Check memory card or CF (adapter).
229	"IRREGULAR FILE SYSTEM"	Error on internal file. Sub error shows the detail of internal error.	It is necessary to check the content (sub error) of file and to set up again.
230	"TRAY WRAPPING IMAGE IS NOT REGISTERED"	Image of package ** is not programmed	Image of package must be registered.
231	"THE MEMORY OF CF CARD IS INSUFFICIENT"	Additional data can no longer be stored.	CF capacity is at the limit or CF is faulty.

Chapter 15 Error Codes and Troubleshooting

15.3 ERROR CODE (0300 -)

No.	Message	Symptom or Phenomenon	Response or Check
301	"THE EMERGENCY STOP SWITCH IS PRESSED"	The emergency stop switch is blinking red on the wrapping unit display.	Release emergency stop switch.
302	"THE EMERGENCY STOP SWITCH IS NOT PRESSED"	This occurs when the emergency stop switch is not pressed.	Press the emergency stop switch.
303	"THE FRONT COVER IS OPEN"	Occurs when the front cover is open before operation.	Close the front cover
304	"RIGHT SIDE COVER IS OPEN" "THE INFEED LOWER COVER IS OPEN"	This occurs when the infeed lower unit cover is open before operation.	Close the infeed lower cover.
305	LOWER INFEED DOOR IS OPEN	Occurs when the infeed unit is open before operation.	Set the infeed unit.
306	"RIGHT SIDE FILM REMOVAL DOOR IS OPEN"	Occurs when the right side film removal cover is open before operation.	Close right side film removal door.
307	"LEFT SIDE FILM REMOVAL DOOR IS OPEN"	Occurs when the left side film removal cover is open before operation.	Close left side film removal door.
308	RIGHT SIDE FILM LOADING DOOR IS OPEN	Occurs when the right film replacement cover is open before operation.	Close right film replacement door.
309	"LEFT SIDE FILM EXCHANGE DOOR IS OPEN"	Occurs when the left side film replacement cover is open before operation.	Close left side film replacement door.
310	"LEFT SIDE COVER IS OPEN" "THE OUTFEED HAS PULLED UP"	Occurs when the outfeed unit is pushed up before operation.	Lower outfeed unit.
312	"EXTRA LABELS REMAIN"	Label remains in the printer when operation started. Separated by Bit. Bit0 : Printer no. 1 Bit1 : Printer no. 2 Bit2 : Printer no. 3 Bit3 : Printer no. 4 Bit7 : Applicator Bit11 : Product in the wrapper	Remove the label according to the sub-error.
313	"THE PRINTER THERMAL HEAD IS IN UP POSITION"	Set thermal head Separated by Bit. Bit0 : Printer no. 1 Bit1 : Printer no. 2 Bit2 : Printer no. 3 Bit3 : Printer no. 4	According to the sub-error Set thermal head. Check head up sensor.

Chapter 15 Error Codes and Troubleshooting

15.3 ERROR CODE (0300 -)

No.	Message	Symptom or Phenomenon	Response or Check
315	"ITEMS HAVE ACCUMULATED IN STOCK PART"	[OK] button, remove item in stock unit	Confirm that product does not remain in the stock unit. Check capacity detection sensor movement.
316	"MD PRICE IS HIGHER THAN REGULAR PRICE"	Numeric key, [OK] button	Confirm and correct markdown price.
317	"PRICE APIECE IS LOWER THAN REGULAR PRICE"	Numeric key, [OK] button	Set selected price as a bigger difference from the regular price.
318	"MD UNIT PRICE IS HIGHER THAN REGULAR PRICE"	Numeric key, [OK] button	Set markdown unit price less than the regular unit price.
319	"THE ORDER QUANTITY HAS BEEN COMPLETED"	Attempted to turn out more than the designated quantity	Press [OK] and continue with the next operation.
321	"PRICE IS NOT INPUT"	Does not occur when "do not display" is selected for 0 price error	Enter price.
322	"STARTING POINT RETURN PROCESSING IS DONE"	Starting point return processing is performed by pressing the [RETURN] button. Only when the power supply is first turned ON.	Displayed when the power supply is turned ON and each mechanical position returns to default.
323	"THE LABEL ISSUE PATTERN IS NOT SET UP"	Perform label issue pattern setting in system mode.	Perform label issue pattern setting.
324	THE LABEL MASTER IS NOT SET UP	Numeric key, [OK] button	Set label setting master.
325	"WEIGHT IS OUTSIDE THE SETTING RANGE"	[PRINT] button: print label; error will not occur. [STOP] button: will not check weight until next unit is called. Numeric key > resolves error, but does not resolve weight check.	Adjust weight to within the set range
336	"THE ORDER QUANTITY HAS BEEN COMPLETED"	Displayed when "End message" is selected in system data settings in system mode	Confirm order quantity.
337	"IMMEDIATE BEFORE DATA IS DELETED"	This screen is displayed when the data value and items in the wrapper become invalid.	Perform return processing by pressing the [RETURN] button.
339	"MINIMUM VALUE IS LIGHTER THAN FIXED WEIGHT"	[EXECUTE] button: Set fixed weight to the minimum value. [CANCEL] button: Release error.	Set minimum value equal to or larger than the fixed weight. · Set it so the fixed weight \leq minimum value
340	ITEM ELIMINATION WAS PERFORMED	This screen is displayed when the item in the wrapper becomes invalid as a result of item deletion	Press the [RETURN] button to perform return processing.

Chapter 15 Error Codes and Troubleshooting

15.3 ERROR CODE (0300 -)

No.	Message	Symptom or Phenomenon	Response or Check
341	"ITEMS REMAIN ON THE LIFT"	Press the [PLU] button and remove the item after clearing the error.	Confirm no items remain on the lift. Check the commodity on lift detection sensor.
342	THE POS CODE DID NOT REGISTERED	Shown when printing is not allowed in the event of a POS code unregistered error in setting mode 2 (error processing selection settings)	Register POS code
343	THE POS CODE DID NOT REGISTERED	Shown when "no barcode" is set for POS code unregistered error in setting mode 2 (error processing selection settings). This error occurs only when "POS code unregistered error" is set. Labels can be issued, but barcodes will not be printed	Register POS code
347	"THE DOT OF A THERMAL HEAD HAS RUN OUT	[OK] button	Replace thermal head. 1.If you do not have a thermal head: 2.Change the error display in Settings Mode 2 >Error processing selection.
348	"THE SCALE PLATE HAS SEPARATED	(-500g) is displayed due to the separation of the scale plate, etc	Check if the scale plate is separated, check weight.
349	"STORE NO. IS NOT CALLED"	Occurs when call item has been completed but call store no. hasn't been completed and is attempting to change to production during store changeover	Call the store no.
350	"TRAY NO. IS NOT REGISTERED"	Numeric entry, [OK] button	Set tray no.
351	"THE LABEL REMAINS	Remove label, [OK] button	Remove label. Check label sensor.
353	"MEMO PRESET IS ALREADY REGISTERED	The already preset part is shown blinking after the error is canceled.	Operation has become redundant.
355	"TRAY NO. IS NOT REGISTERED"	Numeric keys, [OK] button	Register in the tray master.
356	"NO CF CARD"	[OK] button	Insert CF card.
357	"THERE IS NO DICTIONARY FILE"	[OK] button	Put dictionary file on the CF card.
358	"THE CONNECTION SETUP IS NOT DONE"	Numeric keys, [OK] button	Connect journal printer.
359	"THERE IS NO WORD FILE"	[OK] button	Put word file on the CF card.

Chapter 15 Error Codes and Troubleshooting

15.3 ERROR CODE (0300 -)

No.	Message	Symptom or Phenomenon	Response or Check
360	"THE TENSION ADJUSTMENT IS CHANGED"	*Film Tension adjustment data is changed in normal mode. *Is tension adjustment data repealed? [EXECUTE] DISABLED. [CANCEL] ENABLED. [INFEED] REGISTER TO TRAY MASTER.	
361	THE POWER SUPPLY WAS SWITCHED ON	This error records the power is applied to the error log.	This error number records the power being applied to the error log.
362	THE MODEL SETUP IS NOT COMPLETED	Can only enter test mode and system mode.	Set model settings in test mode.
368	"ITEMS REMAIN IN THE WRAPPER"	The front cover was opened when the wrapper stopped and items remained on the lift.	To close the cover, press the [PLU] key to discharge the item. Added to the total amount.

Chapter 15 Error Codes and Troubleshooting

15.4 ERROR CODE (0400 -)

No.	Message	Symptom or Phenomenon	Check	OMNI-3000
401	THE WRAPPER IS NOT CONNECTED	No 24VDC from wrapper power supply. No red status LEDs on sensors. Cannot clear error message.	The console ~ Wrapper(P-857) connector/harness Check P-857(F1,F2)Check Rear Fuse Panel(F15,F16)Check P-910/P-918/P-857/24V Power Supply Err(Wrapper) /Err	1101
			Communication is not possible between boards P-910 ->P-918 ->P-920. [Response] Press the [Re-try] key to re-attempt communication.. If an error re-occurs, check the list below for probable causes. 1) Connector removed 2) Burned out harness 3) Board P-910 is faulty 4) Board P-918 is faulty 5) Board P-857 is faulty This error can also occur when there is a closed circuit failure in the RS-485 line P-915 and P-916. Check this if this is not repaired by steps 1 through 5. Connect P-916, and P-857 one by one and look for a closed circuit failure.	1102
402	THERE WAS NO RESPONSE FROM WRAPPER	No 24VDC from wrapper power supply. No red status LEDs on sensors. Cannot clear error message.	The console ~ Wrapper(P-857) connector/harness Check P-857(F1,F2)Check Rear Fuse Panel(F15,F16)Check P-910/P-918/P-857/24V Power Supply Err(Wrapper) /Err	1101
			Communication is not possible between boards P-910 ->P-918 ->P-920. [Response] Press the [Re-try] key to re-attempt communication.. If an error re-occurs, check the list below for probable causes. 1) Connector removed 2) Burned out harness 3) Board P-910 is faulty 4) Board P-918 is faulty 5) Board P-857 is faulty This error can also occur when there is a closed circuit failure in the RS-485 line P-915 and P-916. Check this if this is not repaired by steps 1 through 5. Connect P-916, and P-857 one by one and look for a closed circuit failure.	1102
403	THE PROBLEM AROSE IN WRAPPER	Send command and receive command do not match The command sent to P-857 by P-910 and the command that returned from P-857 do not match.	This does not occur during normal operation, but it is believed to occur from the effect of noise. Cancel by restoring power.	1101
406	THE WRAPPER DETECTED THE INSTANT POWER FAILURE	Board P-857 was reset twice	Restore power. If the error re-occurs, check the list below for probable causes. 1) Power to the power unit (AC 200V) is unstable 2) Check the power unit output voltage (DC 24V) Power unit placement	1101
407	THE INSTANT POWER FAILURE OCCURRED BY THE CONSOLE	Board P-857 was reset twice	Restore power. If the error re-occurs, check the list below for probable causes. 1) Power to the power unit (AC 200V) is unstable 2) Check the power unit output voltage (DC 24V) Power unit placement	1101

Chapter 15 Error Codes and Troubleshooting

15.4 ERROR CODE (0400 -)

No.	Message	Symptom or Phenomenon	Check	OMNI-3000
409	THERE WAS NO RESPONSE FROM WRAPPER	P-910<- P-918<- P-857 (P-857 is not responding)	DC24V is not output by the power unit. Remove both P-916 (XJ-17) and check if the same error is displayed. Continue here if the error content changes. Remove the connector (No communication with P-910 and P-857) Harness burn-out (No communication with P-910 and P-857) Board P-857 is faulty Board P-918 is faulty Board P-910 is faulty	1101
410	THE LIFT MOTOR ERROR	Lift moves upward. [Recovers after emergency stop button release.] Lift hits on feeder and left/right change motor. Lift does not move. [Recovers after emergency stop button release.]	1. Foreign object caught in the motor. 2. Harness is damaged or short-circuited between P-857 and servo amplifier. 3. Harness is damaged between P-857 and the electromagnetic contactor. 4. Servo amplifier error. 5. Feeder move middle position sensor error (e.g., lift crashes into the feeder (rear)). 6. P-858 (No. A) error	1103
411	THE RIGHT UP/DN MOTOR ERROR	Film Top/Bottom Motor (Right)	1. Foreign object caught in the motor. 2. Film top/bottom motor (right) error. 3. Film top sensor (right) error. 4. Film bottom sensor (right) error. 5. P-858 (No. B) error.	1110-0001
412	THE LEFT UP/DN MOTOR ERROR	Film Top/Bottom Motor (Left)	1. Foreign object caught in the motor. 2. Film top/bottom motor (left) error. 3. Film top sensor (left) error. 4. Film bottom sensor (left) error. 5. P-858 (No. C) error.	1110-0002
413	THE RIGHT FILM ROLLER DRIVER MOTOR ERROR	Film waiting condition is not good.	1. Foreign object caught in the motor. 2. Feeder motor error. 3. Feeder count sensor error. 4. P-857 error. 5. P-858 (No. B) error.	1114-0001
414	THE LEFT FILM ROLLER DRIVER MOTOR ERROR	Film waiting condition is not good.	1. Foreign object caught in the motor. 2. Feeder motor error. 3. Feeder count sensor error. 4. P-857 error. 5. P-858 (No. C) error.	1114-0002

Chapter 15 Error Codes and Troubleshooting

15.4 ERROR CODE (0400 -)

No.	Message	Symptom or Phenomenon	Check	OMNI-3000
415	THE BACK WIRING MOTOR ERROR	Rear wrap plate does not move.	Rear wrap plate is not at home position.	1104
		Operation error at reset.	Motor brake	
		Rear wrap plate does not move.	Home position photo sensor	
		Rear wrap plate does not move.	Motor	
		Slow-moving.	Wrap plate and arms are not parallel binding.	
		Rear wrap plate moves forward.	Limit photo sensor	
		0415-0001: Only when sensor is blocked if canble is damaged/disconnected get error.000		
416	THE LEFT AND RIGHT WRING MOTOR ERROR	Wrap plates do not move.	Side wrap plates are not at home position.	1105
		Action error at reset.	Motor brake	
		Wrap plates do not move.	Home position photo sensor	
		Wrap plates do not move.	Motor	
		Wrap plates stopped at the inside position.	Count photo sensor	
		Fuse	F2A / F2B (rear panel)	
417	THE OUTFEED PUSHER MOTOR ERROR	Pusher does not move.	F2A, F2B	1106
			Out of home position. Dischage pusher is not at home position	
			DC driver	1117
		Pusher does not move. Slow-moving.	Speed control	
		Pusher moves forward.	Limit photo sensor	
	Error during wrapping. Printer has moved forward.	Printer home position micro switch		
418	THE FEEDER MOTOR ERROR	Film is not fed.	Motor	1108
		Film over.	Count photo sensor	
		Error message appears at film detection is unavailable.	Cutter home position sensor (If DIP SW8 on wrapper CPU board P-859 is set)	
		Film over sensor does not check if no counts are detected.		
	Film over (with perforation) and 2 inch strip.			
419	THE RIGHT CLAMP MOTOR ERROR	Switching error (Does not move up and down) (Lever not closed/open/to move)	1. Foreign object caught in the motor. 2. Film grab motor (right) error. 3. Film grab open sensor (right) error. 4. Film grab close sensor (right) error. 5. P-858 (No. B) error.	1111-0001
420	THE BACK FEEDER MOVEMENT MOTOR ERROR	Stops at rear limit	Rear limit photo sensor	1107
			Film width detection sensor(Located on Film Press Roller assembly)	
		Stops front action	Front limit photo sensor	
	No movement	Feeder move motor		
421	INFEEED MOTOR ERROR	Conveyor (infeed claw chain) does not move.(Motor does not move.)	Connection of relay connectors	1109
		Conveyor (chain) does not move. (Motor moves.)	Broken chains	
			ROM_driver	
422	THE LEFT CLAMP MOTOR ERROR	Switching error (Does not move up and down) (Lever not closed/open/to move)	1. Foreign object caught in the motor. 2. Film grab motor (left) error. 3. Film grab open sensor (left) error. 4. Film grab close sensor (left) error. 5. P-858 (No. C) error.	

Chapter 15 Error Codes and Troubleshooting

15.4 ERROR CODE (0400 -)

No.	Message	Symptom or Phenomenon	Check	OMNI-3000
423	THE LIFT CHANGE MOTOR ERROR	When switching the lift	Front/center/back photo sensor Mechanical structure damage Motor F24, F25 Main panel F3 (P-858B)	1112
424	THE OUTFEED CONVEYER MOTOR ERROR	Confirm that the discharge conveyor motor operates smoothly.	Outside conveyor Belt Outside conveyor Motor	1152
430	THE SERVO CONTROLLER ERROR	0430-0000;Servo Amplifier	1. Harness is damaged or short-circuited between P-857 and servo amplifier. 2. Servo amplifier error. 3. P-857 error.	1116
		0430-0011 ~ 0097	[RETURN] button Servo Driver Error L i s t (pdf)	1116
432	THE LIFT ARRIVED AT THE AXIMUM LIMIT	Lift Upper Limit Sensor	1. Lift upper limit sensor error. 2. Lift upper limit height incorrectly programmed. 3. Lift lower limit height incorrectly programmed. 4. Lift original position height incorrectly programmed. 5. Harness damaged or short-circuited between P-857 and servo amplifier. 6. Servo amplifier error. 7. P-857 error.	1136
434	A FOREIGN SUBSTANCE IS BIT UNDER LIFT	Lift Lower Limit Sensor	1. Lift lower limit sensor error. 2. Lift upper limit height incorrectly programmed. 3. Lift lower limit height incorrectly programmed. 4. Lift original position height incorrectly programmed. 5. Harness damaged or short-circuited between P-587 and servo amplifier. 6. Servo amplifier error. 7. P-857 error.	1137-0002
		Foreign objects caught between the lower part of the lift and upper part of the tray stopper (item sensor path is interrupted when the lift starts to descend).	1. Foreign objects caught in the machine. 2. Item sensor sensitivity incorrectly adjusted. 3. Item sensor error. 4. P-858 (No. A) error.	
440	THE EMERGENCY STOP SWITCH WAS PUSHED	Emergency stop button is pressed during operation.	1. Emergency stop button is pressed. 2. Harness is damaged or short-circuited P-857 -> P-858 (No. A) -> P-858 (No. C). 3. Harness damaged between P-857 and electromagnetic contactor. 4. Harness damaged between P-858 (No. C) and the emergency stop button. 5. Harness damaged between electromagnetic contactor and thermal relay. 6. Harness damaged between electromagnetic contactor and emergency stop button. 7. P-857 error.or fuse(F1,F2,F3) 8. P-858 (No. C) error. 9. Electromagnetic contactor error. 10. Thermal relay error. 11. Emergency stop button error. 12. Rear Panel fuse(F21,F22,F23)	1123

Chapter 15 Error Codes and Troubleshooting

15.4 ERROR CODE (0400 -)

No.	Message	Symptom or Phenomenon	Check	OMNI-3000
441	RIGHT SIDE TOP FILM DOOR IS OPEN	Door open during operation	<ol style="list-style-type: none"> 1. Upper-right side door is open. 2. Harness is damaged or short-circuited P-857 -> P-858 (No. B). 3. Harness damaged between P-857 and electromagnetic contactor. 4. Harness damaged between P-858 (No. B) and the upper-right side door. 5. Harness damaged between electromagnetic contactor and thermal relay. 6. Harness damaged between electromagnetic contactor and upper-right side door. 7. P-857 error.or fuse(F1,F2,F3) 8. P-858 (No. B) error. 9. Electromagnetic contactor error. 10. Thermal relay error. 11. Upper-right side door error. 12. Rear Panel fuse(F21,F22,F23) 	1150-0003
442	LEFT SIDE TOP FILM DOOR IS OPEN	Door open during operation	<ol style="list-style-type: none"> 1. Upper-left side door is open. 2. Harness is damaged or short-circuited P-857 -> P-858 (No. A) -> P-858 (No. C). 3. Harness damaged between P-857 and electromagnetic contactor. 4. Harness damaged between P-858 (No. C) and the upper-left side door. 5. Harness damaged between electromagnetic contactor and thermal relay. 6. Harness damaged between electromagnetic contactor and upper-left side door. 7. P-857 error.or fuse(F1,F2,F3) 8. P-858 (No. C) error. 9. Electromagnetic contactor error. 10. Thermal relay error. 11. Upper-left side door error. 12. Rear Panel fuse(F21,F22,F23) 	1150-0006
443	RIGHT SIDE DOOR IS OPEN	Door open during operation	<ol style="list-style-type: none"> 1. Right side door is open. 2. Harness is damaged or short-circuited P-857 -> P-858 (No. B). 3. Harness damaged between P-857 and electromagnetic contactor. 4. Harness damaged between P-858 (No. B) and the right side door. 5. Harness damaged between electromagnetic contactor and thermal relay. 6. Harness damaged between electromagnetic contactor and right side door. 7. P-857 error.or fuse(F1,F2,F3) 8. P-858 (No. B) error. 9. Electromagnetic contactor error. 10. Thermal relay error. 11. Right side door error. 12. Rear Panel fuse(F21,F22,F23) 	1150-0004

Chapter 15 Error Codes and Troubleshooting

15.4 ERROR CODE (0400 -)

No.	Message	Symptom or Phenomenon	Check	OMNI-3000
444	LEFT SIDE DOOR IS OPEN	Door open during operation	<ol style="list-style-type: none"> 1. Left side door is open. 2. Harness is damaged or short-circuited P-857 -> P-858 (No. A) -> P-858 (No. C). 3. Harness damaged between P-857 and electromagnetic contactor. 4. Harness damaged between P-858 (No. C) and the left side door. 5. Harness damaged between electromagnetic contactor and thermal relay. 6. Harness damaged between electromagnetic contactor and left side door. 7. P-857 error.or fuse(F1,F2,F3) 8. P-858 (No. C) error. 9. Electromagnetic contactor error. 10. Thermal relay error. 11. Left side door error. 12. Rear Panel fuse(F21,F22,F23) 	1150-0007
445	THE PRINT DOOR IS OPEN	Door open during operation	<ol style="list-style-type: none"> 1. Printer door is open. 2. Harness is damaged or short-circuited P-857 -> P-858 (No. A) -> P-858 (No. C). 3. Harness damaged between P-857 and electromagnetic contactor. 4. Harness damaged between P-858 (No. C) and the printer door. 5. Harness damaged between electromagnetic contactor and thermal relay. 6. Harness damaged between electromagnetic contactor and printer door. 7. P-857 error.or fuse(F1,F2,F3) 8. P-858 (No. C) error. 9. Electromagnetic contactor error. 10. Thermal relay error. 11. Printer door error. 12. Rear Panel fuse(F21,F22,F23) 	1150-0001
446	LOWER INFEED DOOR IS OPEN	Door open during operation	<ol style="list-style-type: none"> 1. Lower infeed door is open. 2. Harness is damaged or short-circuited P-857 -> P-858 (No. A) -> P-858 (No. C). 3. Harness damaged between P-857 and electromagnetic contactor. 4. Harness damaged between P-858 (No. C) and the lower infeed door. 5. Harness damaged between electromagnetic contactor and thermal relay. 6. Harness damaged between electromagnetic contactor and lower infeed door. 7. P-857 error.or fuse(F1,F2,F3) 8. P-858 (No. C) error. 9. Electromagnetic contactor error. 10. Thermal relay error. 11. Lower infeed door error. 12. Rear Panel fuse(F21,F22,F23) 	1150-0002

Chapter 15 Error Codes and Troubleshooting

15.4 ERROR CODE (0400 -)

No.	Message	Symptom or Phenomenon	Check	OMNI-3000
447	RIGHT SIDE FILM LOADING DOOR IS OPEN	Door open during operation	<ol style="list-style-type: none"> 1. Front-Right side door is open. 2. Harness is damaged or short-circuited P-857 -> P-858 (No. B). 3. Harness damaged between P-857 and electromagnetic contactor. 4. Harness damaged between P-858 (No. B) and the front-right side door. 5. Harness damaged between electromagnetic contactor and thermal relay. 6. Harness damaged between electromagnetic contactor and front-right side door. 7. P-857 error.or fuse(F1,F2,F3) 8. P-858 (No. B) error. 9. Electromagnetic contactor error. 10. Thermal relay error. 11. Front-right side door error. 12. Rear Panel fuse(F21,F22,F23) 	1150-0005
448	DO NOT PUT HAND INTO THE WRAPPER	Foreign object is detected.	<ol style="list-style-type: none"> 1. Foreign object caught in the motor. 2. The item contents have spilled over the rim of the tray. 3. Sensitivity level of the Infeed conveyor manual insertion sensor is incorrectly adjusted. 4. Infeed conveyor sensor error. 5. P-857 error. <p>Note: Sub-error 0000: occurs when wrapping operations are not performed. Sub-error 0001: occurs after wrapping operations are performed.</p>	1128
449	DO NOT PUT HAND INTO THE WRAPPER	Hand is inserted(Conveyor) Hand is inserted(Ejection Pusher)	Hand insertion sensor(Conveyor) Hand insertion sensor(Ejection Pusher)	1147-0001 1147-0002
450	LEFT SIDE FILM LOADING DOOR IS OPEN	Door open during operation	<ol style="list-style-type: none"> 1. Front-Left side door is open. 2. Harness is damaged or short-circuited P-857 -> P-858 (No. A) -> P-858 (No. C). 3. Harness damaged between P-857 and electromagnetic contactor. 4. Harness damaged between P-858 (No. C) and the front-left side door. 5. Harness damaged between electromagnetic contactor and thermal relay. 6. Harness damaged between electromagnetic contactor and front-left side door. 7. P-857 error.or fuse(F1,F2,F3) 8. P-858 (No. C) error. 9. Electromagnetic contactor error. 10. Thermal relay error. 11. Front-left side door error. 12. Rear Panel fuse(F21,F22,F23) 	1150-0008
460	ITEMS WERE NOT THROWN IN	Tray cannot be fed. Fed about 10 mm. Remove the tray on halfway.	<ol style="list-style-type: none"> 1. Item is not fed on the lift properly. 2. Feed stops before the normal position. 3. Lift height is too low. 4. Lift height is too high. 5. Tray length is too short. 6. Tray height is too low. 7. Item sensor sensitivity incorrectly adjusted. 8. Item sensor error. 9. P-857 error. 10. P-858 (No. A) error. 11. One chip CPU (on the P-857) error. 	1133

Chapter 15 Error Codes and Troubleshooting

15.4 ERROR CODE (0400 -)

No.	Message	Symptom or Phenomenon	Check	OMNI-3000
461	FILM OVER AT RIGHT SIDE	Film Over (Left-->Right)	<ol style="list-style-type: none"> 1. Film over error. 2. Film waste detected. 3. Film sensor (front/right) sensitivity incorrectly adjusted. 4. Film sensor (rear/right) sensitivity incorrectly adjusted. 5. Film sensor (front/right) error. 6. Film sensor (rear/right) error. 7. Film count sensor error. 8. Film cutter clutch brake (right) error. 9. Film cutter original position sensor (right) error. 10. P-857 error. 11. P-858 (No. B) error. 	1127-0001
462	FILM OVER AT LEFT SIDE	Film Over (Right--->Left)	<ol style="list-style-type: none"> 1. Film over error. 2. Film waste detected. 3. Film sensor (front/right) sensitivity incorrectly adjusted. 4. Film sensor (rear/right) sensitivity incorrectly adjusted. 5. Film sensor (front/right) error. 6. Film sensor (rear/right) error. 7. Film count sensor error. 8. Film cutter clutch brake (left) error. 9. Film cutter original position sensor (left) error. 10. P-857 error. 11. P-858 (No. C) error. 	1127-0002
463	THE RIGHT-HAND SIDE FILM WAS LOST	Film Depleted (Right)	<ol style="list-style-type: none"> 1. End of film. 2. Film taken-in right. 3. Film roller clutch brake (right) error. 4. Film sensor (right/front) sensitivity incorrectly adjusted. 5. Film sensor (right/rear). 6. Film sensor (right/front) error. 7. Film sensor (right/rear) error. 8. P-857 error. 9. P-858 (No. B) error. <p>Note: Film depleted error will not occur when P-857 DIP switch No. 8 (SW1) is set to ON while the power is on. This setting used only when responding to an emergency, normally it is set to OFF.</p>	1119-0001
464	THE LEFT-HAND SIDE FILM WAS LOST	Film Depleted (Left)	<ol style="list-style-type: none"> 1. End of film. 2. Film taken-in left. 3. Film roller clutch brake (left) error. 4. Film sensor (right/front) sensitivity incorrectly adjusted. 5. Film sensor (right/rear). 6. Film sensor (right/front) error. 7. Film sensor (right/rear) error. 8. P-857 error. 9. P-858 (No. C) error. <p>Note: Film depleted error will not occur when P-857 DIP switch No. 8 (SW1) is set to ON while the power is on. This setting used only when responding to an emergency, normally it is set to OFF.</p>	1119-0002

Chapter 15 Error Codes and Troubleshooting

15.4 ERROR CODE (0400 -)

No.	Message	Symptom or Phenomenon	Check	OMNI-3000
471	THE PROBLEM AROSE IN THE WRAPPER	Package does not infeed. Error beeps when package is placed on infeed. Can recall one PLU but not another. No Roll Set, Film Feed, Return, or printer move (Left to Right).	200 volts AC Check Fuse(F3, F4)(250V, 5A) P-858/A Wrapper control board (Left side)	1153-0000
472	THE PROBLEM AROSE IN THE WRAPPER	0000-0255 : P-857-P-858 IONET No Response err 0256-0511 : SERVO CONTROLLER-P857 RS-422 Response err 0512- : Wrapper Communication errors (I2NET Err)	1.Harness damaged or short-circuited between P-857 and servo amplifier. 2.Connection (between P-857 and amplifier) Lower limit Proximity sensor P-857 3. P-858 (No. A) DIP switch incorrectly set. No. 1 ON No. 2 OFF No. 3 OFF No. 4 OFF P-858 (No. A) error. 4. P-858 (No. B) DIP switch incorrectly set. No. 1 OFF No. 2 ON No. 3 OFF No. 4 OFF P-858 (No. B) error. 5. P-857 DIP switch (SW1) incorrectly set. With option ON Without option OFF No. 1 OFF No. 2 ON No. 3 ON No. 4 OFF No. 5 Overflow sensor option No. 6 ON No. 7 OFF No. 8 OFF P-857 error. 6. P-858 (No. C) DIP switch incorrectly set. No. 1 ON No. 2 ON No. 3 OFF No. 4 OFF P-858 (No. C) error. 7. P-858 (No.A/B/C) Fuse F1,F2,F3 8. Abnormal noise.A FOREIGN SUBSTANCE IS BIT UNDER LIFT 9. A foreign substance is bit under lift	1122
473	THE PROBLEM AROSE AT SEAL HEATER	Pusher does not move.(Wrapper DCB controller error)	1. Ejection pusher motor error. 2. DC brushless controller error. 3. P-857 error.	1117
474	SOLENOID ERROR(0005)	Separator Solenoid (Right)	This does not occur during normal operation, but it is believed to occur from the effect of noise.	1129-0005
	SOLENOID ERROR(0006)	Separator Solenoid (Left)	This does not occur during normal operation, but it is believed to occur from the effect of noise.	1129-0006
	SOLENOID ERROR(0007)	Film Retention Solenoid (Upper/Right)	This does not occur during normal operation, but it is believed to occur from the effect of noise.	1129-0007
	SOLENOID ERROR(0008)	Film Retention Solenoid (Lower/Right)	This does not occur during normal operation, but it is believed to occur from the effect of noise.	1129-0008
	SOLENOID ERROR(0009)	Film Retention Solenoid (Left)	This does not occur during normal operation, but it is believed to occur from the effect of noise.	1129-0009

Chapter 15 Error Codes and Troubleshooting

15.4 ERROR CODE (0400 -)

No.	Message	Symptom or Phenomenon	Check	OMNI-3000
475	THE LIFT CONTACTS THE FEEDER	Lifter does not rise.	Tray size (large/small) incorrectly programmed - Check Tray Master Feeder movement mid point photo sensor	1135-0000
476	WRONG TRAY IS INSERTED	The wrapper detected the narrow-side dimensions of the infeed tray are more than 50mm larger than the selected tray. The narrow-side dimensions detected by the wrapper are shown in the sub-error. Tray settings and infeed tray are different.	There was a difference of greater than 50mm between the tray infeed by the scale unit and the near-side measurements by the commodity on-lift detection sensor. In case of this error, it can be considered that the commodity on lift sensor is soiled. Clean the commodity on lift detection sensor. Adjust commodity on lift detection sensor sensitivity.	
479	"THE LEFT PLUG OPENING/CLOSING ARE NOT SET"	Error message appeared at start.	Check if emergency stop button is pressed.	1124-0000
481	THE RIGHT CUTTER HAS NOT RETURNED (FILM CUTTER)(0001) THE LEFT CUTTER HAS NOT RETURNED (FILM CUTTER)(0002)	Film over (no perforation)	Clutch	1115-0001 1115-0002
		Film over (with perforation)	Home position photo sensor	
		Film winds around roller.(Two perforations)	Brake	

Chapter 15 Error Codes and Troubleshooting

15.5 ERROR CODE (0600 -)

No.	Message	Symptom or Phenomenon	Check
601	"THE APPLICATOR WAS NOT CONNECTED"	<p>[OK] : Cut communication with the applicator. Operate without the applicator.</p> <p>[Re-try] : Check connection with the applicator. The error is cleared if connection is confirmed.</p> <p>Operation without the applicator is possible after pressing the [OK] button.</p>	<p>Press the [Re-try] key to re-attempt communication. If the same error occurs, consider the following causes:</p> <ol style="list-style-type: none"> 1) Unplugged connector 2) Harness short or break 3) P-910 board malfunction 4) P-918 board malfunction 5) P-916 platform malfunction
602	"THERE IS NO RESPONSE FROM THE APPLICATOR"	<p>Communication wasn't achieved between the console and the applicator.</p> <p>Communication errors after power ON result in this error.</p>	<p>[OK] : Cut communication with the applicator. Operate without the applicator.</p> <p>[Re-try] : Check connection with the applicator. The error is cleared if connection is confirmed.</p> <p>Operation without the applicator is possible after pressing the [OK] button.</p> <p>P-910 <- P-918 <- P-916 (No response from P-916)</p> <p>Press the [Re-try] key to re-attempt communication. If the same error occurs, consider the following causes:</p> <ol style="list-style-type: none"> 1) Unplugged connector 2) Harness short 3) P-910 board malfunction 4) P-918 board malfunction 5) P-916 platform malfunction
603	"THE PROBLEM AROSE IN THE APPLICATOR"	<p>The applicator command sent and the applicator command received are not the same</p> <p>The command sent from P-910 to P-916 and the command that returned from P-916 are different.</p>	<p>This does not occur during normal operation, but it is believed to occur from the effects of noise. Cancel by restoring power.</p>
604	"THE INSTANT POWER FAILURE OCCURRED BY THE CONSOLE"	<p>P-910 board was reset twice.</p>	<p>Restore power.</p> <ol style="list-style-type: none"> 1) Input power (AC 200V) to power unit (U220) is unstable 2) Check power unit (U220) output voltage (DC 24V)
605	"THE INSTANT POWER FAILURE WAS DETECTED WITH APPLICATOR"	<p>Board P-916 was reset</p>	<p>Restore power.</p> <ol style="list-style-type: none"> 1) Power unit (U1) input power (AC 200V) is unstable 2) Check output voltage (DC 24V) of power unit (U1)
606	"THE PROBLEM AROSE IN THE APPLICATOR"	<p>Applicator alignment data has not been set</p>	<p>Applicator alignment needs to be performed after clearing.</p> <p>Perform applicator alignment in test mode.</p>

Chapter 15 Error Codes and Troubleshooting

15.5 ERROR CODE (0600 -)

No.	Message	Symptom or Phenomenon	Check
607	"THE PROBLEM AROSE IN THE APPLICATOR"	Applicator data checksum value is abnormal.	Applicator alignment needs to be performed after clearing. Perform applicator alignment in test mode.
608	"OPERATION OF THE APPLICATOR STOPPED"	Power to the applicator was shut off during operation.	Cover open. Clear the emergency stop switch. Check power switch (U1) input voltage (AC 200V) Check power switch (U1) output voltage (DC 24V)
609	"ADSORPTION OF LABEL WAS NOT COMPLETED"	Applicator failed in label application.	[RETURN] button Check application unit
610	"THERE IS NO LABEL ATTACHMENT"	There was no label when application was attempted	[RETURN] button Check application unit.
611	"A LABEL WAS NOT ABLE TO BE STUCK"	Label could not be pasted to the commodity. -0000 Pasting preparation was not completed when pasting time was sped up. -0001 Previous pasting was not completed when pasting timing signal was received. -0002 The tray height message was not received when the pasting timing signal was received.	[RETURN] button Respond according to the sub-error contents. Please check if the communication line connector is loosening. Also, check if application timing signal line is damaged (close to short circuit).
612	"A LABEL WAS NOT ABLE TO BE STUCK"	Pasting is carried out by the pasting timing signal sent from board P-857 and received by P-916. This signal was not received.	Cable disconnected between P-857 (J5) -> P-916 (XJ-18) Replace board P-857 Replace board P-916
613	"THE LABEL REMAINS IN THE APPLICATOR"	A label remains in the applicator after application	Cover open applicator the label Apply the label on the tray. Press the [RETURN] button after removing the label
614	"DO NOT PUT A HAND INTO A FRONT COVER"	Applicator (discharge unit) safety sensor (B25) did not receive light during applicator operation.	[RETURN] button Service applicator (discharge unit) safety sensor (B25)

Chapter 15 Error Codes and Troubleshooting

15.5 ERROR CODE (0600 -)

No.	Message	Symptom or Phenomenon	Check
615	"ABNORMAL ERROR IN THE APPLICATOR OPERATE"	Sensors did not block or emit light as planned during motor operation [Sub-error] -000 X axis moving left -001 X axis moving right -010 Y axis moving forward -011 Y axis moving backward -020 Z axis moving up -021 Z axis moving down	[RETURN] button 1.Check that DC 24V is being output by power unit U51. Confirm by checking the green power unit LED is illuminated. 2.Respond by confirming each sensor is inputting normally by a sensor test. 3.Please check if the mechanical components are bent or damaged.
616	"THE SENSOR OF THE APPLICATOR IS UNUSUAL"	A sensor that does not have light blocked is blocked from light. [Sub-error] -000 X axis -010 Y axis -020 Z axis	Sub-error] -000 Check the X axis sensor (Is it blocked from light even though there is no detection board?) -010 Check the Y axis sensor (Is it blocked from light even though there is no detection board?) -020 Check the Z axis sensor (Is it blocked from light even though there is no detection board?)
621	"THE PROBLEM AROSE IN THE APPLICATOR"	Check the main software and applicator software versions and confirm the combination is compatible.	Check P-910 software and P-916 software, replace software.
630	"A SUM VALUE ERROR OF RECEIVING DATA"	The data sum value from the console did not match upon download.	Re-download. If the same error re-occurs, replace the applicator software in the CF.
631	"FLASH ROM WRITE-IN BUSY ERROR"	Applicator software download cannot end normally.	Re-download.
632	"A FLASH WRITE-IN ERROR"	Applicator software download cannot end normally [Sub-error] -000 Flash ROM data write or delete failure. -003 Flash ROM checksum write failure. -099 Power failure occurred during download.	Re-download. If the same error re-occurs, replace P-916.
633	"THE PROBLEM AROSE IN THE APPLICATOR"	There is no applicator application program [Sub-error] -000 Bad checksum or no application. -001 The application ran too quickly.	Re-download the program. If the same error re-occurs, replace P-916.

Chapter 15 Error Codes and Troubleshooting

15.5 ERROR CODE (0600 -)

No.	Message	Symptom or Phenomenon	Check
650	THERE WAS NO RESPONSE FROM THE APPLICATOR	<p>Unable to communicate between the console and applicator. [OK] -> Cut communication with the applicator. Operate without the applicator. [RETRY] -> Check connection with the applicator. The error is cleared if connection can be confirmed. [Remarks] It is possible to operate without the applicator after pressing the [OK] button.</p>	<p>Press the [RETRY] key and attempt communication. The consider the following causes if the error re-occurs:</p> <ol style="list-style-type: none"> 1) Unplugged connector 2) Shorted harness 3) Board P-910 malfunction 4) Board P-918 malfunction 5) Board P-916 malfunction

Chapter 15 Error Codes and Troubleshooting

15.6 ERROR CODE (0700 -)

No.	Message	Symptom or Phenomenon	Response or Check
701	"IT CANNOT COMMUNICATE WITH THE PRINTER #1"	[OK]-> Clear the error [RETRY]-> Re-check communication with the printer.	Check each communication harness 1.Check the harness after referring to the wiring diagram. 2.Replace boards P-909(X271)(XJ-11,XJ-17), P-918(XJ-5)(XJ-1,2,8,9), and P-910(XJ-1).
702	"THERE IS NO RESPONSE FROM THE PRINTER #1"	[OK] -> Clear the error [RETRY] -> Re-check communication with the printer. · Operation without the printer is possible after pressing the [OK] button. · Check the connection of printers #1 and #2 with P910 and P909. · Check the printer #3 and #4 communication cable. · The printer number in the error heading changes according to the error.	Check each communication harness 1.Check the harness after referring to the wiring diagram. 2.Replace boards P-909(X271)(XJ-11,XJ-17), P-918(XJ-5)(XJ-1,2,8,9), and P-910(XJ-1).
703	"THE PRINTER #1 IS MALFUNCTIONING"	The print queue is full	1.Restore power 2.If it doesn't restore, replace P-909.
704	"THE PRINTER #1 IS MALFUNCTIONING"	Processed an invalid parameter.	1.Restore power 2.If it doesn't restore, replace P-909.
705	"THE PRINTER #1 IS MALFUNCTIONING"	Too many command processes received	1.Restore power 2.If it doesn't restore, initialize printer unit memory.
706	"THE PRINTER #1 DETECTED THE INSTANT POWER FAILURE"	A different command was received before the version command.	Clear by restoring power.
707	"THE PRINTER #1 IS NOT INITIALIZED"	The printer is not initialized	Initialize printer unit memory in "Printer adjustment" in test mode.
708	"FORMAT NO. OF THE PRINTER #1 HAS ERROR"	Sent format No. 0, Oxff.	This error does not normally occur.
709	"FORMAT OF THE PRINTER #1 HAS NOT BEEN SET"	The printer attempted to print a non-existent format number.	Check the format number.
710	"LABEL OF THE PRINTER #1 WAS COMPLETED"	Attempted to begin printing, but the label sensor continued to receive light.	Press the [OK] button after replacing the label Check label sensor.
711	"THE LABEL SIZE OF THE PRINTER #1 ERROR"	Printer label size error.	Press the [OK] button after removing the sent label. Perform label sensitivity adjustment.

Chapter 15 Error Codes and Troubleshooting

15.6 ERROR CODE (0700 -)

No.	Message	Symptom or Phenomenon	Response or Check
715	"THERMAL HEAD OF THE PRINTER #1 HAS RUN OUT"	[Sub-error] 0001 : The portion that as run out has no effect on printing. 0002 : It has run out in the formatted printing area. 0003 : The barcode portion has run out.	If you continue using the head in accordance with the sub-error, change the error display in Setting Mode 2 (error setting), and the head can be used for a short while. Replace the thermal head when necessary.
716	"THERMAL HEAD OF THE PRINTER #1 IS GOING UP"	The thermal head was raised when printing began.	Press the [OK] button after setting the thermal head Replace the thermal head. Setting thermal head up proxy switch
717	"CONTROL BOARD OF THE PRINTER #1 IS UNUSUAL"	Unable to detect an interrupt signal from the printer control board (P-909).	1.Restore power. 2.If the same error re-occurs, replace P-909.
718	"FILE TRANSFER OF THE PRINTER #1 WENT WRONG"	File transfer from the console to the printer failed. Error occurs during printing from printers #3 and #4. [Sub-error] 0000 : No CF card on the printer side. 0001 : File failed to open. 0002 : File failed to close. 0003 : File read failure. 0004 : File write failure. 0005 : No file.	Respond according to the sub-error.
719	"LABEL ADSORPTION TIMING UNDETECTABLE"	Occurs in printers #1 and #2. The console turns ON the label issue timing signal the moment the applicator starts absorption. This timing signal could not be detected.	This error does not normally occur.
720	"THE BATTERY OF THE PRINTER #1 IS UNUSUAL"	P-910 battery switch is OFF or exhausted. Cannot access the battery other than test mode or system mode. (omni-4000 is no err)	Turn ON the battery switch. Battery charge, P-910*-2 may be faulty.
721	"IMAGE DEPLOYMENT ERROR"	4M exceeded when attempting to exchange the image file internal data.	Delete unnecessary images.

15.6 ERROR CODE (0700 -)

No.	Message	Symptom or Phenomenon	Response or Check
-----	---------	-----------------------	-------------------

<p>1. Printer Errors. Error screens differ depending on operation mode Even for the same error, the error screen changes depending on the situation. (1) Wrapping/pricing modes, pricing mode (2) Label issue with wrapper front cover opened (3) OMNi-4000</p>
--

Chapter 15 Error Codes and Troubleshooting

15.7 ERROR CODE (1400 -)

No.	Message	Symptom or Phenomenon	Response or Check
1401	"IT CANNOT COMMUNICATE WITH THE KEY PROCESSING BOARD"	Cannot cancel the error due to inoperable number keys. (OMNi)	key processing board check
1402	"THE KEY PROCESSING BOARD INITIALIZATION ERROR"	Cannot cancel the error due to initialization number keys. (OMNi)	initialization key processing board check keyboard change

Chapter 15 Error Codes and Troubleshooting

15.8 ERROR CODE (1600 -)

No.	Message	Symptom or Phenomenon	Response or Check
1600	"A MEMORY SETUP OF THE SCALE IS UNUSUAL"	Scale (P-930) memory settings are abnormal.	Perform spring span. If the same error occurs, replace board P-930.
1601	"SPAN ADJUSTMENT OF THE SCALE INCOMPLETE"	Scale (P-930) span adjustment incomplete.	Perform spring span. If the same error occurs, replace board P-930.
1602	"INITIALIZATION THE SCALE IS NOT COMPLETED"	Scale (P-930) initialization has not been completed.	Perform spring span. If the same error occurs, replace board P-930.
1618	"CHECK THE SCALE"	Check that nothing is in touch with weighing conveyor. (Wind, vibration)	Remove the weighing conveyor to check if anything is in touch with weighing conveyor and remove foreign objects if any. Also wind or vibration check is necessary.
1619	"TAKE THE ARTICLE ON THE SCALE PLATE"	An item remains on the scale.	Remove item from the weighing platter.
1621	"THERE IS NO RESPONSE FROM THE SCALE"	There is no response from the scale (P-930). Restore power after checking scale connection 01:Invalid text 02:Initializing 03:Out of range 04:Unstable 05:Unable to change between A/D 06:Spring scale not set (Span adjustment is not complete) 07:Unable to send (Scale debug response) 08-16:WPL 17:Upper/lower limit error 18:Check scale 19:Remove item from the weighing platter 20:Power failure detected 21:No response from the scale board (connection error) 22:Communication error (connection error) 23:Communication error (connection error)	Check harness, connector Replace P-930(XJ1,4,5)-X292-X291-P-910(XJ8)
1622	"COMMUNICATION IMPOSSIBLE WITH THE SCALE"	Cannot communicate with the scale (P-930) Restore power after checking scale connection.	Check harness, connector Replace P-930 (XJ1,4,5)-X292-X291-P-910(XJ8)
1623	"COMMUNICATION IMPOSSIBLE WITH THE SCALE"	Cannot communicate with the scale (P-930) Restore power after checking scale connection.	Check harness, connector Replace P-930 (XJ1,4,5)-X292-X291-P-910(XJ8)



Design and specifications are subject to change without notice.

44 SANNO-CHO, SHOGOIN, SAKYO-KU
KYOTO, 606-8392 JAPAN
PHONE: 81-75-771-4141
FACSIMILE: 81-75-751-1634
URL: <http://www.ishidajapan.com>
