



**WEIGHING SOLUTIONS
FOR LOGISTICS**

CATALOGUE

 **DINI ARCEO**
Scales - Weighing systems

A RICE LAKE WEIGHING SYSTEMS COMPANY

www.diniargeo.com

			 Legal for trade	Printer	Stainless steel	 ATEX	Higher capacity up to 2,500 kg	High resolution 0,1 kg	For US pallet	Electric traction tiller	Swivelling head	
PALLET TRUCK SCALES	TPWN						○		●			p. 8
	TPWLK		●	●			○	○	○			p. 10
	TPWP		●	●			○	○	○		●	p. 12
	TPW TOUCH		●	●			○	○	○		●	p. 14
	TPW EX 3GD		●			●	○	○	○		●	p. 16
	TPW EX 2GD		●			●	○	○	○		●	p. 18
	TPWI		●	○	●						○	p. 22
	TPWI HYGIENX		●	○	●			○				p. 24
	TPWI EX 3GD		●		●	●					○	p. 26
	TPWI EX 2GD		●		●	●					○	p. 28
TPW "E-FORCE"		●	●				●		●		p. 32	
PALLET SCALES	EPWL		●									p. 36
	EPWLI		●		●							p. 38



A RICE LAKE WEIGHING SYSTEMS COMPANY

WEIGHING SOLUTIONS FOR LOGISTICS

Mobile Weighing
Systems
Manufacturer



Dini Argeo - Head Quarter & Production Line - Fiorano Modenese, Italy

Dini Argeo is an Italian company specializing in the design and production of scales and weighing systems, which stand out for quality, reliability and versatility of use, gaining increasing success on markets all over the world.

"For over 20 years Dini Argeo has been designing and manufacturing weighing solutions that stand out for their quality and reliability in the world of industry and logistics."

In this catalogue you can find the different solutions for weighing, lifting and handling in industrial environments, even harsh ones, and inside the warehouse: pallet truck scales, pallet scales and weighing solutions to transform your forklift and electric pallet truck into a real mobile scale. Discover also our dimensioning systems that combine weight and volume data and are ideal for monitoring the flow of goods in and out of the warehouse.

The wide range of weighing solutions with customisable features makes Dini Argeo products easy to integrate into your warehouse and logistic lines. Thanks to its team of highly qualified engineers, Dini Argeo is also able to develop fully customised, certified weighing solutions and firmware in compliance with international standards.

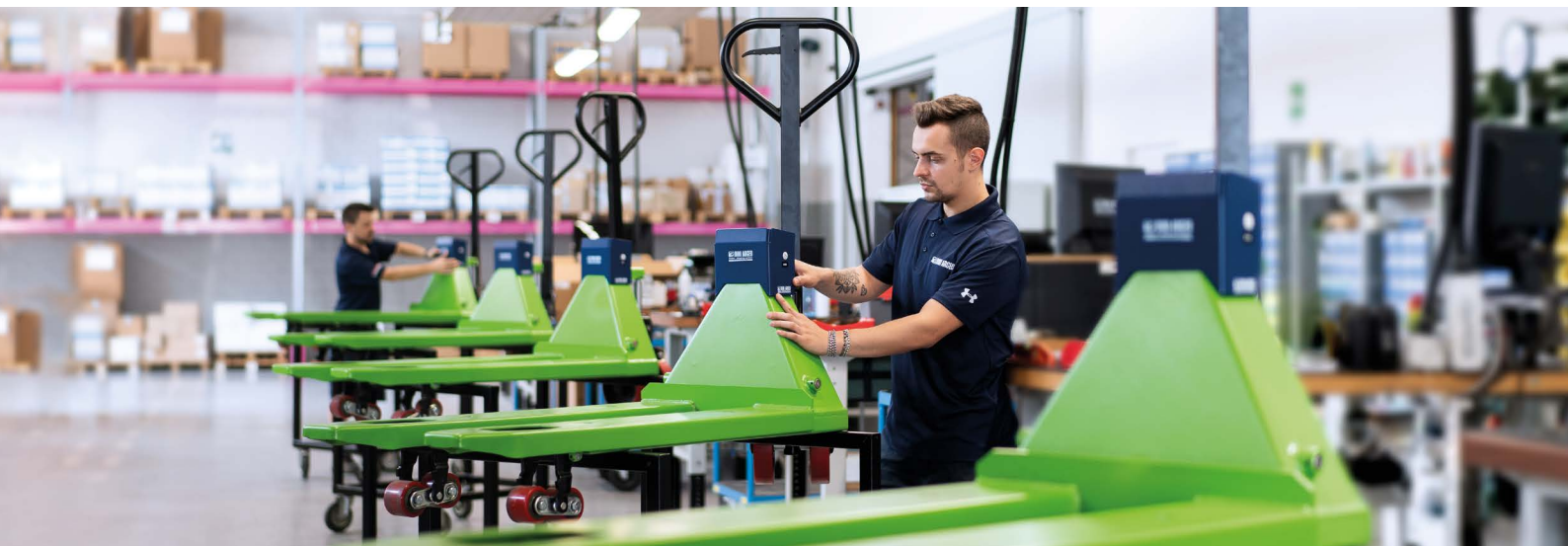

PEDRIELLI
MODENA

PORTATA 6.3 t.



INDEX

PALLET TRUCK SCALES

WEIGHING SOLUTIONS FOR LOGISTICS

p. 6

Dini Argeo pallet truck scales are manufactured in Italy, calibrated and tested in Dini Argeo facilities in Fiorano Modenese and delivered with a test certificate attesting the declared accuracy. Equipped with sturdy and resistant construction, in stainless steel or ATEX environments, they are the ideal solution for weighing and handling outside and inside the warehouse.

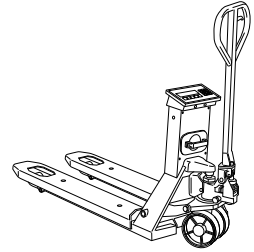

PALLET SCALES

WEIGHING SOLUTIONS FOR LOGISTICS

p. 34

Dini Argeo pallet scales are the ideal solution to create mobile weighing stations in your warehouse. Thanks to the display with column connected to the platform, reading the weight and controlling the movements made will be simple and fast.

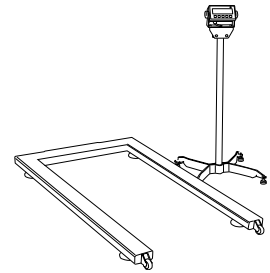

WEIGHING KITS FOR FORKLIFTS AND ELECTRIC PALLET TRUCKS

WEIGHING SOLUTIONS FOR LOGISTICS

p. 40

Dini Argeo boasts a range of weighing systems designed specifically for forklifts and electric pallet trucks: from pressure sensors, to weighing forks and plates to turn your forklift and electric pallet truck into a mobile scale.

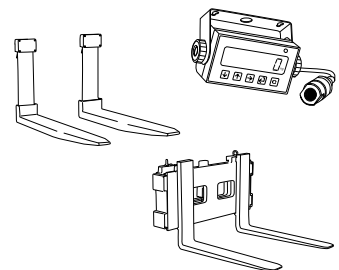

DIMENSIONING SYSTEMS

WEIGHING SOLUTIONS FOR LOGISTICS

p. 52

The Rice Lake Weighing Systems brand dimensioning systems combine the concept of weight and volume in order to determine the total size of packages and control the flow of incoming and outgoing goods.

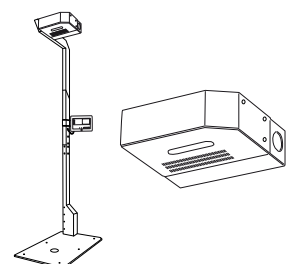

HAND PALLET TRUCK SCALES

“

High-quality pallet truck scales, sturdy and accurate, specifically designed to meet all weighing needs in terms of handling and logistic requirements.

”

HAND PALLET TRUCK SCALES

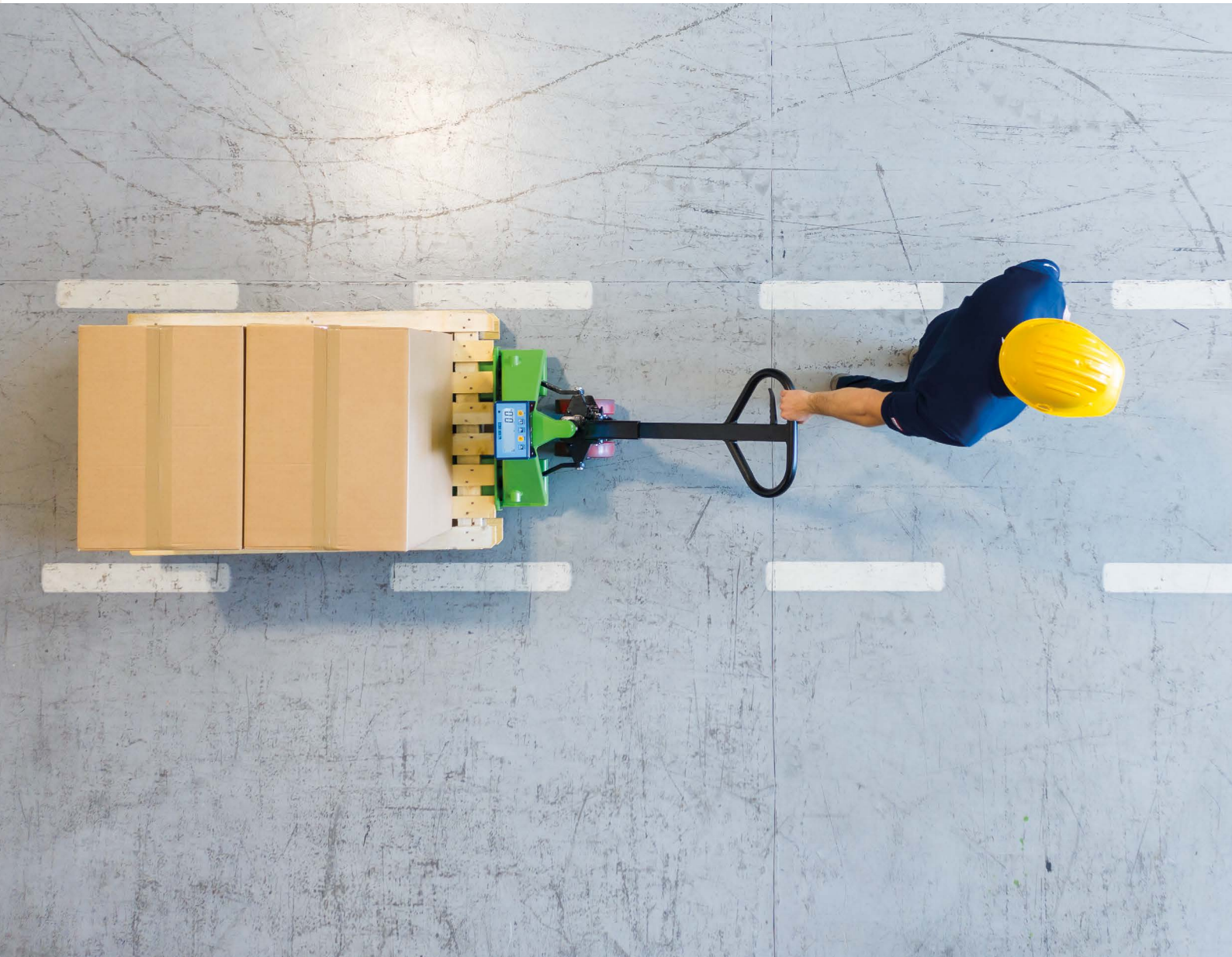

TPWN

ENTRY LEVEL

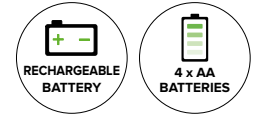

550 mm

EUROPALLET

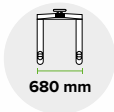

680 mm

US PALLET



 **MANUFACTURED IN ITALY**

The only entry level pallet truck scale with high-end features.

Choose it because:

- 200 g resolution as standard
- Packaged one by one in a sturdy, stackable, 100% recyclable protective packaging
- The best price-quality ratio

VERSION FOR EUROPALLET (550 mm)		
Power supply	Max. Capacity (kg)	d (kg)
AA Battery	2.000	0,2
Rechargeable Battery	2.000	0,2

VERSION FOR US PALLET (680 mm)		
Power supply	Max. Capacity (kg)	d (kg)
Rechargeable Battery	2.000	1

Upon request:

- Capacity 2.500 kg (Accuracy between 2.000 / 2.500 kg is 2 kg)

Other special capacities / resolutions: upon request.

Other special versions: upon request.

Main Functions

- **WEIGHT TOTALISATION**
- **PIECE COUNTING**
- **UNIT CONVERTER:** kg/lb, free conversion factor
- **ZEROING**
- **TARE**
- **PRESET TARE**

Main Features

Display	Shockproof 25 mm LCD backlit display
Display protection cover	As standard
Brightness	Adjustable brightness
IP protection rating	IP40 / IP54 with keyboard protection cover
Accuracy* (Internal use)	± 1 kg
Keyboard	5-key waterproof
Structure	Oven-fire painted steel
Steering wheels	Double polyurethane rollers
Load wheels	Double polyurethane loading rollers
Lift pump	Quick-lifting hydraulic pump
Load cells	Alloy steel, IP67 protection
Auto switch-off	Programmable
Power supply	Integrated rechargeable battery or 4 AA batteries
Operating time	About 80 h / About 40 h (with Duracell® AA batteries)
Battery recharge	Via a 230 Vac 50 Hz charger (8 h for full recharge) with EU power plug**
Operating temperature range	-10 / +40 °C
Communication to external devices	-

(*) Weighing of goods on EUROPALLET with distributed load.

(**) UK, AU, US versions: upon request.

Certifications

- 2006/42/EU (Machine Directive)
- 2014/30/EU (EMC)
- 2014/35/EU (LVD)
- 2011/65/EU (RoHS)
- 2014/31/EU (NAWI)

Technical Drawing (mm)

EUROPALLET / EPAL (550 mm)

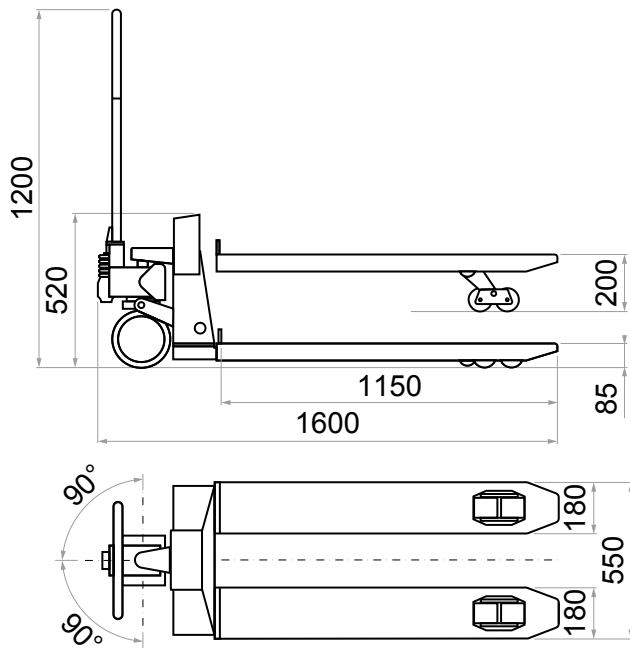

US PALLET (680 mm)

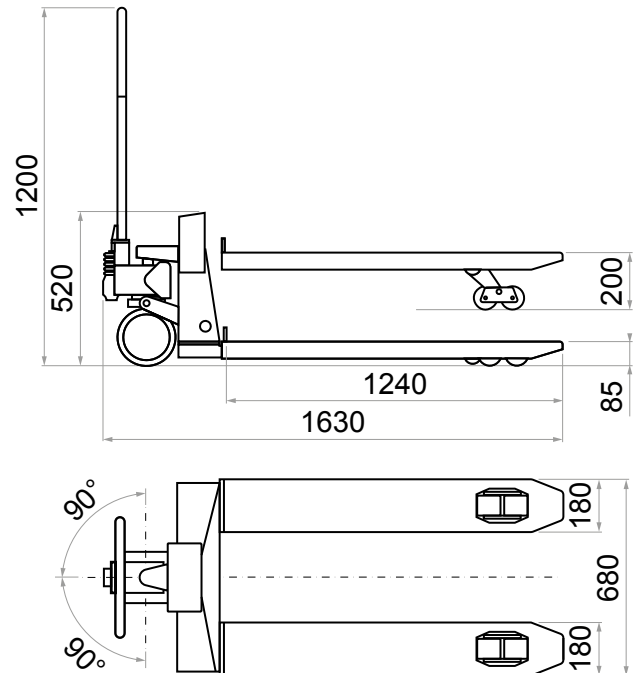

Accessories

- PC SOFTWARE FOR DATA STORAGE
- PARKING BRAKE



Robust packaging for optimal protection of your pallet truck.
100% recyclable.

€ For prices and additional accessories see the price list.

TPWLK

LEGAL FOR TRADE WITH PRINTER

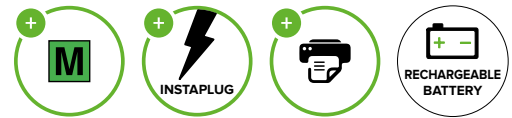

550 mm
EUROPALLET



680 mm
US PALLET



MANUFACTURED
IN ITALY

Professional pallet truck scale, with optional printer ideal for tracking weighing. Certified accuracy thanks to the legal-for-trade approval.

Choose it because:

- Approved for legal-for-trade use
- Also available with integrated printer
- Instaplug technology that allows for 24/7 use

M	Printer	Max. Capacity (kg)	d (kg)	e (kg)
		2.000	0,2	
M		2.000 [1.000 - 2.000]		0,5 - 1
	Printer	2.000	0,2	
M	Printer	2.000 [1.000 - 2.000]		0,5 - 1

M Legal for trade. Printer Integrated Printer and Date & Time.

Upon request:

- M Capacity 600 kg, Resolution 0,2 kg
- M Capacity 600 / 1.500 kg, Resolution 0,2 / 0,5 kg
- M Capacity 1.500 kg
- M Capacity 2.500 kg
- Capacity 2.500 kg (Accuracy between 2.000 / 2.500 kg is 2 kg)
- Forks for US pallet (680 mm)

Other special capacities / resolutions: upon request.

Other special versions: upon request.

Main Functions

- WEIGHT TOTALISATION
- PIECE COUNTING
- UNIT CONVERTER: kg/lb, free conversion factor
- 50 TARE MEMORY
- PRINT NUMERIC IDs
- ZEROING
- TARE
- PRESET TARE

Main Features

Display	25 mm LCD backlit display	
Brightness	Adjustable brightness	
IP protection rating	IP65 / IP20 for models with printer	
Accuracy*	Internal use	± 1 kg
	Legal for trade M	In accordance with Directive 2014/31/EU
Keyboard	17-key waterproof	
Structure	Oven-fire painted steel	
Steering wheels	Double polyurethane rollers	
Load wheels	Double polyurethane loading rollers	
Lift pump	Quick-lifting hydraulic pump	
Load cells	4, in stainless steel, with IP68 protection	
Auto switch-off	5 min, programmable	
Power supply	"Instaplug" removable rechargeable battery	
Operating time	About 80 h	
Battery recharge	Via a 230 Vac 50 Hz charger (8 h for full recharge) with EU power plug**	
Operating temperature range	-10 / +40 °C	
Communication to external devices	Optional radio-frequency, Wi-Fi or Bluetooth	

(*) Weighing of goods on EUROPALLET with distributed load.

(**) UK, AU, US versions: upon request.

Certifications

- 2006/42/EU (Machine Directive)
- 2014/30/EU (EMC)
- 2014/35/EU (LVD)
- 2011/65/EU (RoHS)
- 2014/31/EU (NAWI)

Technical Drawing (mm)

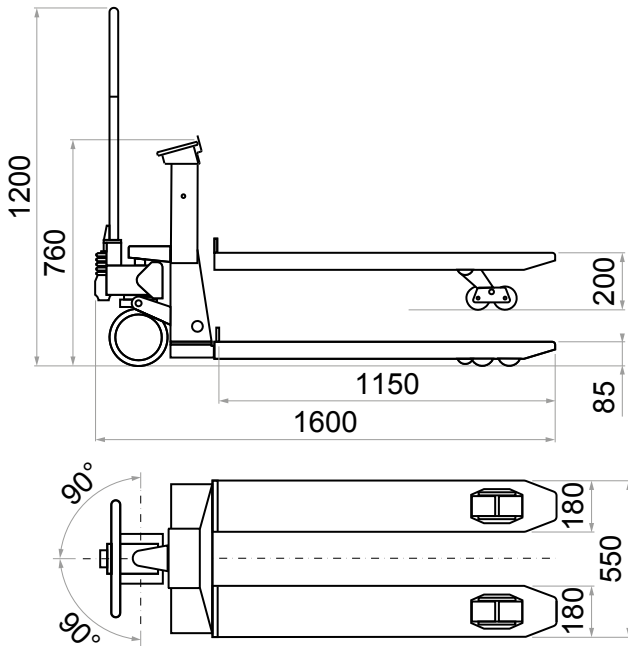

Accessories

- ADDITIONAL BATTERY FOR 24/7 USE
- BLUETOOTH INTERFACE
- RADIO 2,4 GHz INTERFACE
- Wi-Fi
- PC SOFTWARE FOR DATA STORAGE
- FISCAL MEMORY
- PARKING BRAKE
- USB MEMORY FOR DATA STORAGE
- ANTISTATIC STEERING WHEELS
- VULKOLLAN / NYLON STEERING WHEELS



Robust packaging for optimal protection of your pallet truck.
100% recyclable.

€ For prices and additional accessories see the price list.

TPWP

HIGH RESOLUTION

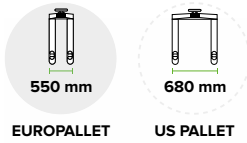
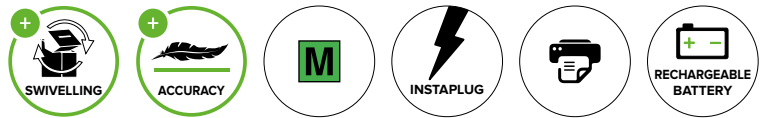

550 mm

EUROPALLET

680 mm

US PALLET



MANUFACTURED
IN ITALY

Professional pallet truck scale ideal to reach the highest weighing resolution.

Choose it because:

- High resolution up to 100 g
- Swivelling head for the best reading comfort during manual dosing
- Instaplug technology that allows for 24/7 use

M	Printer	Max. Capacity (kg)	d (kg)	e (kg)
		2.000	0,2	
M	Printer	2.000 [1.000 - 2.000]		0,5 - 1

M Legal for trade. Printer Integrated Printer and Date & Time.

Upon request:

- M Capacity 600 kg, Resolution 0,2 kg
- M Capacity 600 / 1.500 kg, Resolution 0,2 / 0,5 kg
- M Capacity 1.500 kg
- M Capacity 2.500 kg
- High Resolution 0,1 kg (Accuracy is the same as the standard version)
- Capacity 2.500 kg (Accuracy between 2.000 / 2.500 kg is 2 kg)
- Forks for US pallet (680 mm)

Other special capacities / resolutions: upon request.

Other special versions: upon request.

Main Functions

- WEIGHT TOTALISATION
- PIECE COUNTING
- UNIT CONVERTER: kg/lb, free conversion factor
- 50 TARE MEMORY
- PRINT NUMERIC IDs
- ZEROING
- TARE
- PRESET TARE

Main Features

Swivelling column head	As standard, $\pm 160^\circ$ rotation
Display	25 mm LCD backlit display
Brightness	Adjustable brightness
IP protection rating	IP65 / IP20 for models with printer
Accuracy*	Internal use
	Legal for trade M
Keyboard	17-key waterproof
Structure	Oven-fire painted steel
Steering wheels	Double polyurethane rollers
Load wheels	Double polyurethane loading rollers
Lift pump	Quick-lifting hydraulic pump
Load cells	4, in stainless steel, with IP68 protection
Auto switch-off	5 min, programmable
Power supply	"Instaplug" removable rechargeable battery
Operating time	About 60 h
Battery recharge	Via a 230 Vac 50 Hz charger (8 h for full recharge) with EU power plug**
Operating temperature range	-10 / +40 °C
Communication to external devices	Optional radio-frequency, Wi-Fi or Bluetooth

(*) Weighing of goods on EUROPALLET with distributed load.

(**) UK, AU, US versions: upon request.

Certifications

- 2006/42/EU (Machine Directive)
- 2014/30/EU (EMC)
- 2014/35/EU (LVD)
- 2011/65/EU (RoHS)
- 2014/31/EU (NAWI)

Technical Drawing (mm)

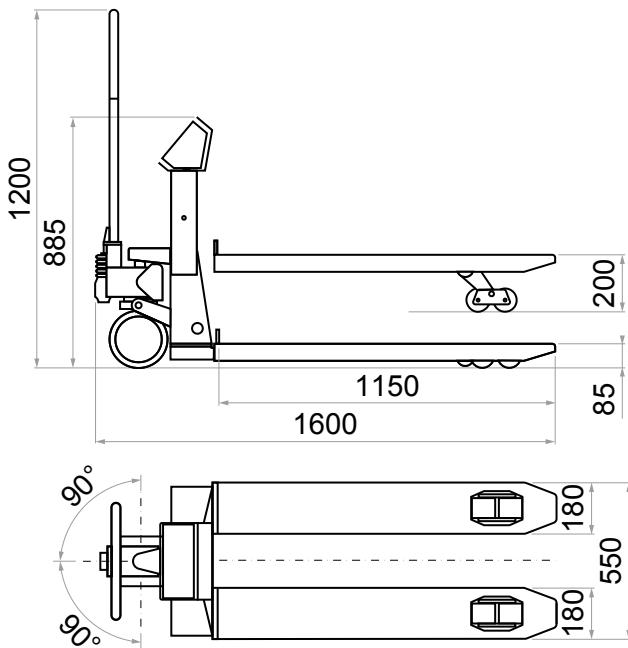

Accessories

- ADDITIONAL BATTERY FOR 24/7 USE
- BLUETOOTH INTERFACE
- RADIO 2,4 GHz INTERFACE
- Wi-Fi
- PC SOFTWARE FOR DATA STORAGE
- FISCAL MEMORY
- PARKING BRAKE
- USB MEMORY FOR DATA STORAGE
- ANTISTATIC STEERING WHEELS
- VULKOLLAN / NYLON STEERING WHEELS



Robust packaging for optimal protection of your pallet truck.
100% recyclable.

€ For prices and additional accessories see the price list.

TPW TOUCH

TOUCH SCREEN

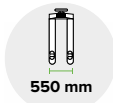
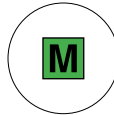

550 mm
EUROPALLET

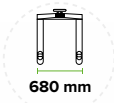

680 mm
US PALLET



MANUFACTURED
IN ITALY

Professional pallet truck scale specific for advanced data management and communication with the main computer systems.

Choose it because:

- Fitted with touch screen indicator as standard
- Database management and data processing
- Can be integrated with Wi-Fi, barcode reader and Bluetooth

M	Printer	Max. Capacity (kg)	d (kg)	e (kg)
		2.000	0,2	
M	Printer	2.000 [1.000 - 2.000]		0,5 - 1

M Legal for trade. Printer Integrated Printer and Date & Time.

Upon request:

- M Capacity 600 kg, Resolution 0,2 kg
- M Capacity 600 / 1.500 kg, Resolution 0,2 / 0,5 kg
- M Capacity 1.500 kg
- M Capacity 2.500 kg
- High Resolution 0,1 kg (Accuracy is the same as the standard version)
- Capacity 2.500 kg (Accuracy between 2.000 / 2.500 kg is 2 kg)
- Forks for US pallet (680 mm)

Other special capacities / resolutions: upon request.

Other special versions: upon request.

Main Functions

- **DATABASE MANAGEMENT:** Products, Customers, Suppliers and Tares
- **FULL PROGRAMMABILITY**
- **15 PROGRAMMABLE TEXTS**
- **DATA TRANSFER**
- **FISCAL MEMORY**
- **APPLICATION PROGRAM FOR:** Totalisation, Piece Counting, Dosage
- **NUMERIC IDs**
- **TARE**
- **PRESET TARE**
- **ZEROING**

Main Features

Swivelling column head	As standard, $\pm 160^\circ$ rotation	
Display	5,7" touch screen backlit color display. Resistive technology	
IP protection rating	IP65 / IP20 for models with printer	
Accuracy*	Internal use	$\pm 0,5$ kg
	Legal for trade M	In accordance with Directive 2014/31/EU
Keyboard	Touch screen	
Structure	Oven-fire painted steel	
Steering wheels	Double polyurethane rollers	
Load wheels	Double polyurethane loading rollers	
Lift pump	Quick-lifting hydraulic pump	
Load cells	4, in stainless steel, with IP68 protection	
Auto switch-off	5 min, programmable	
Power supply	"Instaplug" removable rechargeable battery	
Operating time	About 10 h	
Battery recharge	Via a 230 Vac 50 Hz charger (8 h for full recharge) with EU power plug**	
Operating temperature range	-10 / +40 °C	
Communication to external devices	Optional radio-frequency, Wi-Fi or Bluetooth	
Fiscal memory (Alibi memory)	As standard	
Date / Time	As standard	
Database	1.000 articles, 300 tares, 200 customers / suppliers	
Programmability	Free memory spaces for customised application program	
Free alphanumeric texts	15	

(*) Weighing of goods on EUROPALLET with distributed load.

(**) UK, AU, US versions: upon request.

Certifications

- 2006/42/EU (Machine Directive)
- 2014/30/EU (EMC)
- 2014/35/EU (LVD)
- 2011/65/EU (RoHS)
- 2014/31/EU (NAWI)

Technical Drawing (mm)

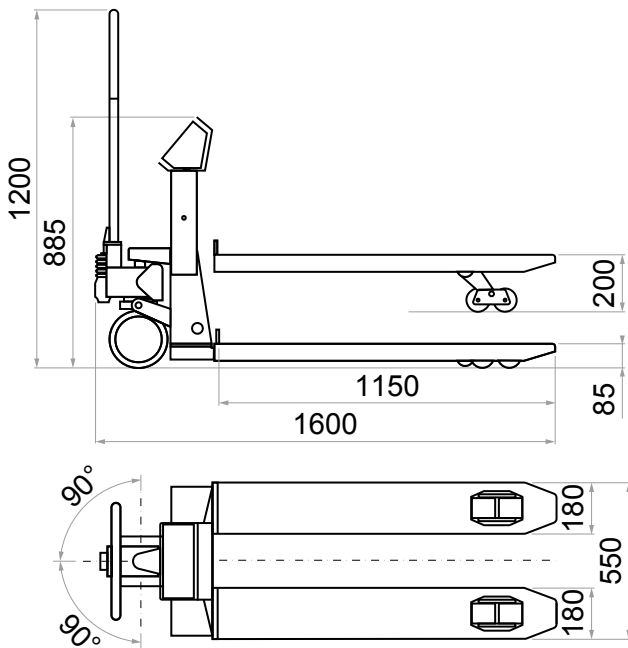

Accessories

- BARCODE READER
- ADDITIONAL BATTERY FOR 24/7 USE
- BLUETOOTH INTERFACE
- RADIO 2,4 GHz INTERFACE
- Wi-Fi
- PC SOFTWARE FOR DATA STORAGE
- PARKING BRAKE
- USB MEMORY FOR DATA STORAGE
- STAINLESS STEEL FORKS
- ANTISTATIC STEERING WHEELS
- VULKOLLAN / NYLON STEERING WHEELS
- APPLICATION SOFTWARES



Robust packaging for optimal protection of your pallet truck.
100% recyclable.

€ For prices and additional accessories see the price list.

TPW EX 3GD

3GD ATEX



550 mm

EUROPALLET

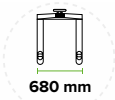

680 mm

US PALLET



MANUFACTURED
IN ITALY

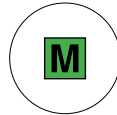

Pallet truck scale for ATEX hazardous areas (zones 2 and 22).

Choose it because:

- Made with ATEX-certified components
- High resolution up to 100 g
- Wireless communication to safe zone

M	Max. Capacity (kg)	d (kg)	e (kg)
	2.000	0,2	
M	2.000 [1.000 - 2.000]		0,5 - 1

M Legal for trade.

Upon request:

- M Capacity 600 kg, Resolution 0,2 kg
- M Capacity 600 / 1.500 kg, Resolution 0,2 / 0,5 kg
- M Capacity 1.500 kg
- M Capacity 2.500 kg
- High Resolution 0,1 kg (Accuracy is the same as the standard version)
- Capacity 2.500 kg (Accuracy between 2.000 / 2.500 kg is 2 kg)
- Forks for US pallet (680 mm)
- Stainless Steel Forks

Other special capacities / resolutions: upon request.

Other special versions: upon request.

Main Functions

- WEIGHT TOTALISATION
- PIECE COUNTING
- UNIT CONVERTER: kg/lb, free conversion factor
- 50 TARE MEMORY
- ZEROING
- TARE
- PRESET TARE

Main Features

Swivelling column head	As standard, $\pm 160^\circ$ rotation	
Display	25 mm LCD backlit display	
Brightness	Standard brightness	
IP protection rating	IP68	
Accuracy*	Internal use	$\pm 0,5$ kg
	Legal for trade M	In accordance with Directive 2014/31/EU
Keyboard	17-key waterproof	
Structure	Body	Oven-fire painted steel
	Forks	Stainless steel as option
Steering wheels	Double polyurethane rollers	
Load wheels	Double polyurethane loading rollers	
Lift pump	Quick-lifting hydraulic pump	
Load cells	4, ATEX certified, in stainless steel, with IP68 protection	
Auto switch-off	5 min, programmable	
Power supply	ATEX removable rechargeable battery	
Operating time	About 100 h	
Battery recharge (in safe area)	Via a 230 Vac 50 Hz charger (8 h for full recharge) with EU, UK, AU and US power plugs	
Operating temperature range	-10 / +40 °C	
Communication to external devices	Optional radio-frequency and Wi-Fi	

(*) Weighing of goods on EUROPALLET with distributed load.

Certifications

- 2006/42/EU (Machine Directive)
- 2014/30/EU (EMC)
- 2014/35/EU (LVD)
- 2011/65/EU (RoHS)
- 2014/31/EU (NAWI)
- 2014/34/EU (ATEX)

Technical Drawing (mm)

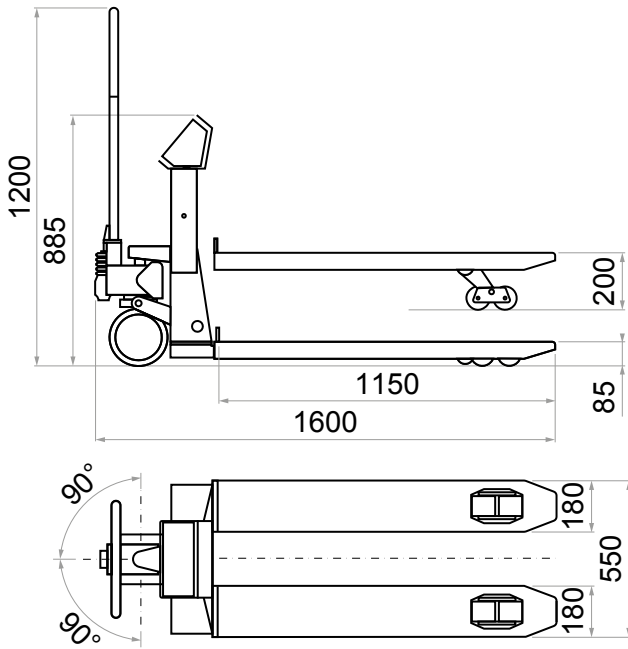

Accessories

- ADDITIONAL BATTERY FOR 24/7 USE
- RADIO 2,4 GHz INTERFACE
- Wi-Fi
- PC SOFTWARE FOR DATA STORAGE
- FISCAL MEMORY
- PARKING BRAKE
- ANTISTATIC STEERING WHEELS
- NYLON STEERING WHEELS
- INTEGRATED MEMORY (8 GB) FOR DATA STORAGE

€ For prices and additional accessories see the price list.

TPW EX 2GD

2GD ATEX

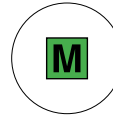

550 mm

EUROPALLET

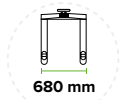

680 mm

US PALLET



MANUFACTURED IN ITALY

Pallet truck scale for ATEX hazardous areas (zones 1 and 21, 2 and 22).

Choose it because:

- Made with ATEX-certified components
- High resolution up to 100 g
- Approved for legal-for-trade use

M	Max. Capacity (kg)	d (kg)	e (kg)
	2.000	0,2	
M	2.000 [1.000 - 2.000]		0,5 - 1

M Legal for trade.

Upon request:

- M Capacity 600 kg, Resolution 0,2 kg
- M Capacity 600 / 1.500 kg, Resolution 0,2 / 0,5 kg
- M Capacity 1.500 kg
- M Capacity 2.500 kg
- High Resolution 0,1 kg (Accuracy is the same as the standard version)
- Capacity 2.500 kg (Accuracy between 2.000 / 2.500 kg is 2 kg)
- Forks for US pallet (680 mm)
- Stainless Steel Forks

Other special capacities / resolutions: upon request.

Other special versions: upon request.

Main Functions

- WEIGHT TOTALISATION
- PIECE COUNTING
- UNIT CONVERTER: kg/lb, free conversion factor
- 50 TARE MEMORY
- ZEROING
- TARE
- PRESET TARE

Main Features

Swivelling column head	As standard, $\pm 160^\circ$ rotation	
Display	25 mm LCD display	
Brightness	Standard brightness	
IP protection rating	IP68	
Accuracy*	Internal use	$\pm 0,5$ kg
	Legal for trade M	In accordance with Directive 2014/31/EU
Keyboard	17-key waterproof	
Structure	Body	Oven-fire painted steel
	Forks	Stainless steel as option
Steering wheels	Double polyurethane rollers	
Load wheels	Double polyurethane loading rollers	
Lift pump	Quick-lifting hydraulic pump	
Load cells	4, ATEX certified, in stainless steel, with IP68 protection	
Auto switch-off	5 min, programmable	
Power supply	ATEX removable rechargeable battery	
Operating time	About 150 h	
Battery recharge (in safe area)	Via a 230 Vac 50 Hz charger (8 h for full recharge) with EU, UK, AU and US power plugs	
Operating temperature range	-10 / +40 °C	
Communication to external devices	-	

(*) Weighing of goods on EUROPALLET with distributed load.

Certifications

- 2006/42/EU (Machine Directive)
- 2014/30/EU (EMC)
- 2014/35/EU (LVD)
- 2011/65/EU (RoHS)
- 2014/31/EU (NAWI)
- 2014/34/EU (ATEX)

Technical Drawing (mm)

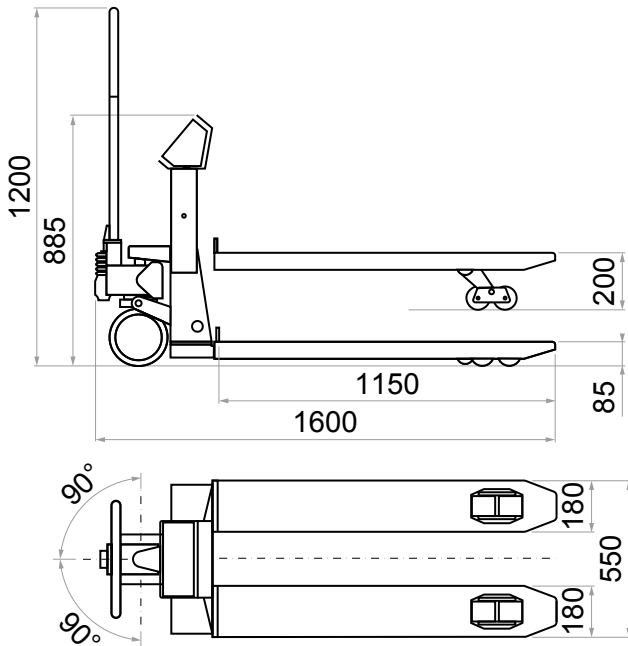

Accessories

- ADDITIONAL BATTERY FOR 24/7 USE
- PARKING BRAKE
- ANTISTATIC STEERING WHEELS
- NYLON STEERING WHEELS

€ For prices and additional accessories see the price list.

STAINLESS STEEL PALLET TRUCK SCALES

“

Wide range of stainless steel pallet truck scales, specifically designed for use in environments that require strict hygienic standards or harsh environments.

”

STAINLESS STEEL PALLET TRUCK SCALES



TPWI

MULTIPURPOSE

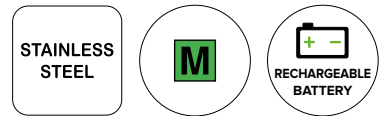

MANUFACTURED
IN ITALY

Stainless steel pallet truck scale suitable for all types of application.

Choose it because:

- Specific for environments with strict hygienic standards or harsh environments
- Approved for legal-for-trade use
- Can print and transmit data to the main computer systems

M	☞	Max. Capacity (kg)	d (kg)	e (kg)
		2.000 [500 - 1.000 - 2.000]	0,2 - 0,5 - 1	
M		2.000 [1.000 - 2.000]		0,5 - 1

M Legal for trade.

Other special capacities / resolutions: upon request.

Other special versions: upon request.

Main Functions

- WEIGHT TOTALISATION
- PIECE COUNTING
- UNIT CONVERTER: kg/lb, free conversion factor
- 50 TARE MEMORY
- ZEROING
- TARE
- PRESET TARE

Main Features

Display	25 mm LCD backlit display	
Brightness	Adjustable brightness	
IP protection rating	IP65	
Accuracy*	Internal use	± 1 kg
	Legal for trade M	In accordance with Directive 2014/31/EU
Keyboard	17-key waterproof	
Structure	Body	AISI 304 stainless steel
	Forks	AISI 316 stainless steel
Steering wheels	Double nylon rollers	
Load wheels	Double nylon loading rollers	
Lift pump	Stainless steel quick-lifting hydraulic pump	
Load cells	4, in stainless steel, with IP68 protection	
Auto switch-off	5 min, programmable	
Power supply	Integrated rechargeable battery	
Operating time	About 50 h	
Battery recharge	Via a 230 Vac 50 Hz charger (8 h for full recharge) with EU, UK, AU and US power plugs	
Operating temperature range	-10 / +40 °C	
Communication to external devices	Optional radio-frequency, Wi-Fi or Bluetooth	

(*) Weighing of goods on EUROPALLET with distributed load.

Certifications

- 2006/42/EU (Machine Directive)
- 2014/30/EU (EMC)
- 2014/35/EU (LVD)
- 2011/65/EU (RoHS)
- 2014/31/EU (NAWI)

Technical Drawing (mm)

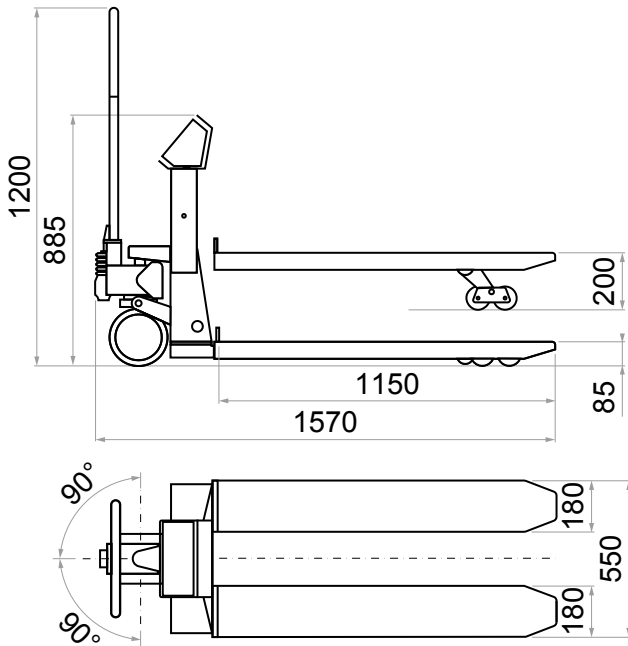

Accessories

- BLUETOOTH INTERFACE
- RADIO 2,4 GHz INTERFACE
- Wi-Fi
- PC SOFTWARE FOR DATA STORAGE
- FISCAL MEMORY
- STAINLESS STEEL PARKING BRAKE
- VULKOLLAN STEERING WHEELS
- STAINLESS STEEL THERMAL PRINTER

€ For prices and additional accessories see the price list.

TPWI HYGIENX

FOOD, CHEMICAL AND
PHARMACEUTICAL INDUSTRY

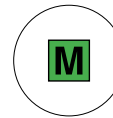

MANUFACTURED
IN ITALY

AISI 304 stainless steel pallet truck scale specifically designed for environments with high hygiene requirements, such as the food industry food, chemical and pharmaceutical industries.

Choose it because:

- Made with IP69K load cells, hermetically sealed, for maximum protection against water and corrosion
- Fully washable and sanitazable
- Approved for legal-for-trade use

M	Max. Capacity (kg)	d (kg)	e (kg)
	2.000 [1.000 - 2.000]	0,2 – 0,5	
M	2.000 [1.000 - 2.000]		0,5 - 1

M Legal for trade.

Other special capacities / resolutions: upon request.

Other special versions: upon request.

Main Functions

- **WEIGHT TOTALISATION**
- **PIECE COUNTING**
- **UNIT CONVERTER:** kg/lb, free conversion factor
- **UP TO 20 TARE MEMORY**
- **ZEROING**
- **TARE**
- **PRESET TARE**

Main Features

Display	25 mm LCD backlit display	
Brightness	Adjustable brightness	
IP protection rating	IP68 / IP69K	
Accuracy*	Internal use	± 0,5 kg
	Legal for trade M	In accordance with Directive 2014/31/EU
Keyboard	17 numeric-functional waterproof keyboard	
Structure	Body	AISI 304 stainless steel
	Forks	AISI 304 stainless steel
Steering wheels	Double nylon rollers with polyurethane coating	
Load wheels	Double nylon loading rollers with polyurethane coating	
Lift pump	AISI 304 Stainless steel quick-lifting hydraulic pump	
Load cells	4, in stainless steel, with IP69K protection	
Auto switch-off	Programmable	
Power supply	Integrated rechargeable battery	
Operating time	About 100 h	
Battery recharge	Via a 230 Vac 50 Hz charger (12 h for full recharge) with EU, UK, AU and US power plugs	
Operating temperature range	-10 / +40 °C	
Communication to external devices	Optional radio-frequency, Wi-Fi or Bluetooth	

(*) Weighing of goods on EUROPALLET with distributed load.

Certifications

- 2006/42/EU (Machine Directive)
- 2011/65/EU (RoHS)
- 2014/30/EU (EMC)
- 2014/31/EU (NAWI)
- 2014/35/EU (LVD)

Technical Drawing (mm)

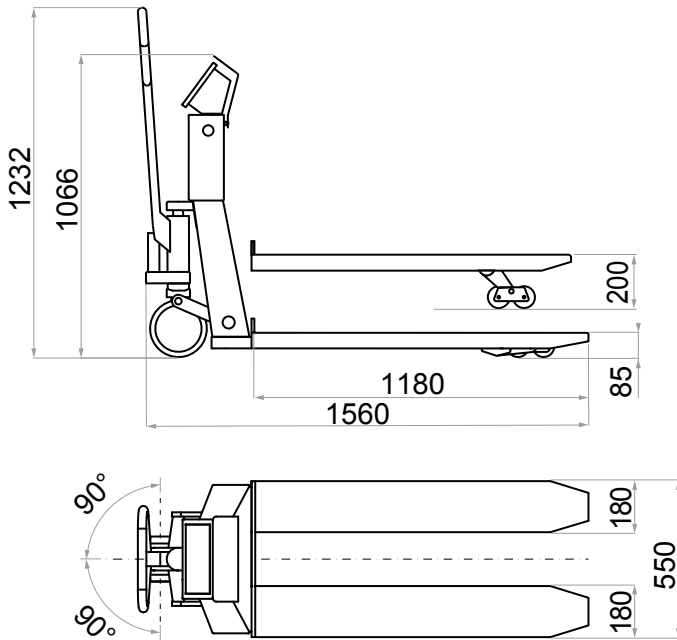

Accessories

- BLUETOOTH INTERFACE
- RADIO 2,4 GHz INTERFACE
- Wi-Fi
- PC SOFTWARE FOR DATA STORAGE
- FISCAL MEMORY
- STAINLESS STEEL PARKING BRAKE
- VULKOLLAN STEERING WHEELS
- STAINLESS STEEL THERMAL PRINTER (IP65)

€ For prices and additional accessories see the price list.

TPWI EX 3GD

STAINLESS STEEL 3GD ATEX

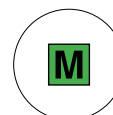

MANUFACTURED
IN ITALY

Stainless steel pallet truck scale for ATEX hazardous areas (zones 2 and 22).

Choose it because:

- Made with ATEX-certified components
- Approved for legal-for-trade use
- Can transmit data to safe zone

M	☞	Max. Capacity (kg)	d (kg)	e (kg)
		2.000 [500 - 1.000 - 2.000]	0,2 - 0,5 - 1	
M		2.000 [1.000 - 2.000]		0,5 - 1

M Legal for trade.

Other special capacities / resolutions: upon request.

Other special versions: upon request.

Main Functions

- WEIGHT TOTALISATION
- PIECE COUNTING
- UNIT CONVERTER: kg/lb, free conversion factor
- 50 TARE MEMORY
- ZEROING
- TARE
- PRESET TARE

Main Features

Display	25 mm LCD backlit display	
Brightness	Standard brightness	
IP protection rating	IP68	
Accuracy*	Internal use	± 1 kg
	Legal for trade M	In accordance with Directive 2014/31/EU
Keyboard	17-key waterproof	
Structure	Body	AISI 304 stainless steel
	Forks	AISI 316 stainless steel
Steering wheels	Double antistatic rollers	
Load wheels	Double polyurethane loading rollers	
Lift pump	Stainless steel quick-lifting hydraulic pump	
Load cells	4, ATEX certified, in stainless steel, with IP68 protection	
Auto switch-off	5 min, programmable	
Power supply	ATEX removable rechargeable battery	
Operating time	About 100 h	
Battery recharge (in safe area)	Via a 230 Vac 50 Hz charger (8 h for full recharge) with EU, UK, AU and US power plugs	
Operating temperature range	-10 / +40 °C	
Communication to external devices	Optional radio-frequency and Wi-Fi	

(*) Weighing of goods on EUROPALLET with distributed load.

Certifications

- 2006/42/EU (Machine Directive)
- 2014/30/EU (EMC)
- 2014/35/EU (LVD)
- 2011/65/EU (RoHS)
- 2014/31/EU (NAWI)
- 2014/34/EU (ATEX)

Technical Drawing (mm)

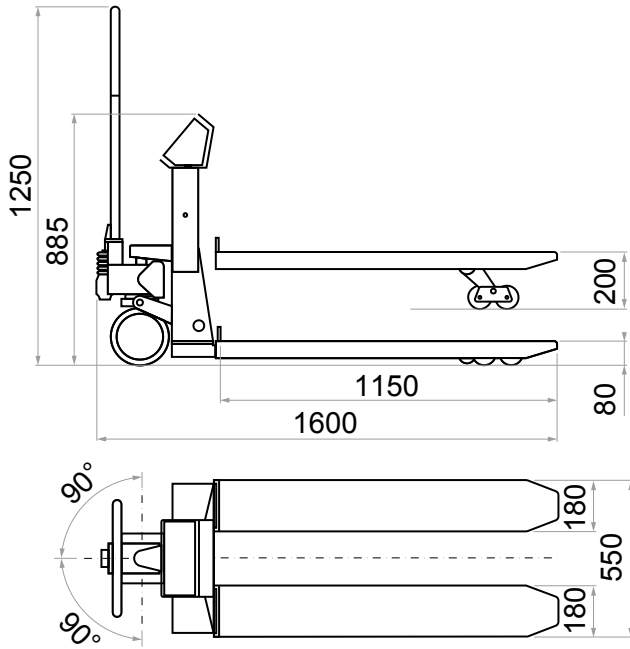

Accessories

- ADDITIONAL BATTERY FOR 24/7 USE
- RADIO 2,4 GHz INTERFACE
- Wi-Fi
- PC SOFTWARE FOR DATA STORAGE
- FISCAL MEMORY
- STAINLESS STEEL PARKING BRAKE
- SWIVELLING HEAD KIT

€ For prices and additional accessories see the price list.

TPWI EX 2GD

STAINLESS STEEL 2GD ATEX



Stainless steel pallet truck scale for ATEX hazardous areas (zones 1 and 21, 2 and 22).

Choose it because:

- Made with ATEX-certified components
- Approved for legal-for-trade use
- Fitted with long-lasting removable battery



MANUFACTURED IN ITALY

M	Max. Capacity (kg)	d (kg)	e (kg)
	2.000 [500 - 1.000 - 2.000]	0,2 - 0,5 - 1	
M	2.000 [1.000 - 2.000]		0,5 - 1

M Legal for trade.

Other special capacities / resolutions: upon request.

Other special versions: upon request.

Main Functions

- WEIGHT TOTALISATION
- PIECE COUNTING
- UNIT CONVERTER: kg/lb, free conversion factor
- 50 TARE MEMORY
- ZEROING
- TARE
- PRESET TARE

Main Features

Display	LCD	
Brightness	Standard brightness	
IP protection rating	IP68	
Accuracy*	Internal use	± 1 kg
	Legal for trade M	In accordance with Directive 2014/31/EU
Keyboard	17-key waterproof	
Structure	Body	AISI 304 stainless steel
	Forks	AISI 316 stainless steel
Steering wheels	Double antistatic rollers	
Load wheels	Double polyurethane loading rollers	
Lift pump	Stainless steel quick-lifting hydraulic pump	
Load cells	4, ATEX certified, in stainless steel, with IP68 protection	
Auto switch-off	5 min, programmable	
Power supply	ATEX removable rechargeable battery	
Operating time	About 150 h	
Battery recharge (in safe area)	Via a 230 Vac 50 Hz charger (12 h for full recharge) with EU, UK, AU and US power plugs	
Operating temperature range	-10 / +40 °C	
Communication to external devices	-	

(*) Weighing of goods on EUROPALLET with distributed load.

Certifications

- 2006/42/EU (Machine Directive)
- 2014/30/EU (EMC)
- 2014/35/EU (LVD)
- 2011/65/EU (RoHS)
- 2014/31/EU (NAWI)
- 2014/34/EU (ATEX)

Technical Drawing (mm)

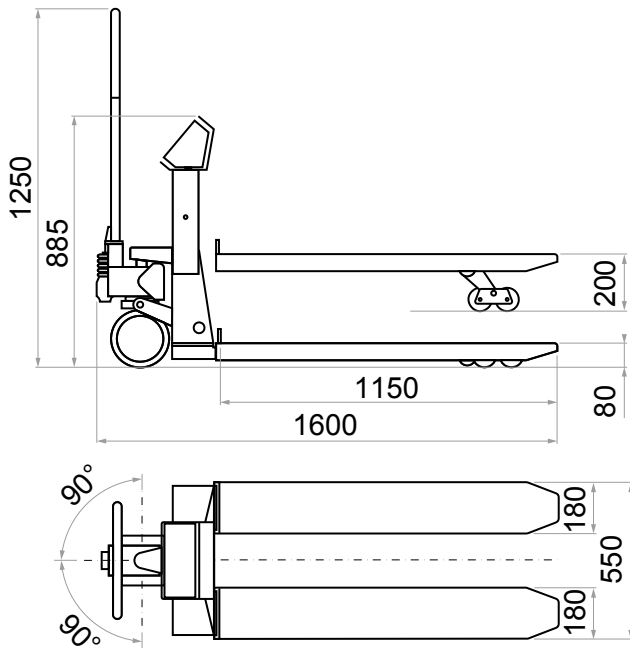

Accessories

- ADDITIONAL BATTERY FOR 24/7 USE
- STAINLESS STEEL PARKING BRAKE
- SWIVELLING HEAD KIT

€ For prices and additional accessories see the price list.



ELECTRIC PALLET TRUCK SCALES

“

Innovative solutions to facilitate handling
inside the warehouse.

”

ELECTRIC PALLET TRUCK SCALES

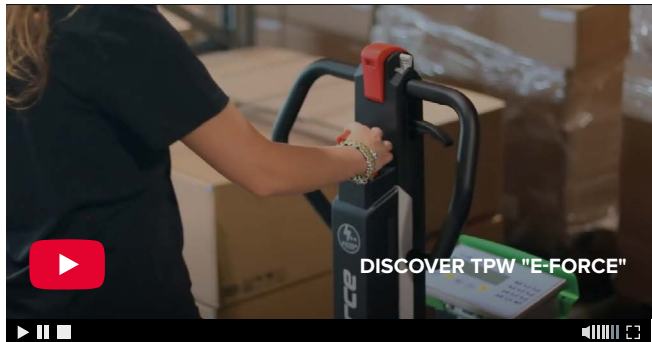

Watch the video to find out more:
**THE ELECTRIC PALLET TRUCK SCALE
FOR YOUR WAREHOUSE**



www.diniargeo.com

TPW "E-FORCE"

ELECTRIC TRACTION TILLER



Innovative pallet truck scale with electric traction tiller that makes weighing and handling extremely easy.

Choose it because:

- Electric tiller
- Extra slim body ideal for narrow places
- 100 g resolution for very accurate weighing



MANUFACTURED
IN ITALY

M	Printer	Max. Capacity (kg)	d (kg)	e (kg)
		1.250	0,1	
		1.250		0,5

M Legal for trade. Integrated Printer and Date & Time.

Other special capacities / resolutions: upon request.

Other special versions: upon request.

Main Functions

- **WEIGHT TOTALISATION**
- **PIECE COUNTING**
- **UNIT CONVERTER:** kg/lb, free conversion factor
- **50 TARE MEMORY**
- **ZEROING**
- **TARE**
- **PRESET TARE**

Main Features

Maximum speed	5 km/h	
Maximum slope	5%	
Display	25 mm LCD backlit display	
Brightness	Adjustable brightness	
IP protection rating	IP54	
Precision*	Internal use	± 0,5 kg
	Legal for trade M	In accordance with Directive 2014/31/EU
Keyboard	17-key waterproof	
Structure	Oven-fire painted steel	
Steering wheels	Double stain-resistant rubber rollers	
Load wheels	Double polyurethane loading rollers	
Lift pump	Quick-lifting hydraulic pump	
Load cells	4, in stainless steel, with IP68 protection for legal-for-trade approved version, IP67 for internal use version	
Auto switch-off	5 min, programmable	
Power supply	Indicator	Removable rechargeable Instaplug battery
	Tiller	Removable rechargeable lithium-ion battery
Operating time	Indicator	Approx. 80 h
	Tiller	Up to 8 h (3 to 5 h for standard use)
Battery recharge	Indicator	Via a 230 Vac 50 Hz charger (8 h for full recharge) with EU power plug**
	Tiller	Optional 2 h quick recharge
Operating temperature range	-10 / +40 °C	
Communication to external devices	Optional radio-frequency, Wi-Fi or Bluetooth	

(*) Weighing of goods on EUROPALLET with distributed load.

(**) UK, AU, US versions: upon request.

Certifications

- 2006/42/EU (Machine Directive)
- 2011/65/EU (RoHS)
- 2014/30/EU (EMC)
- 2014/31/EU (NAWI)
- 2014/35/EU (LVD)

Technical Drawing (mm)

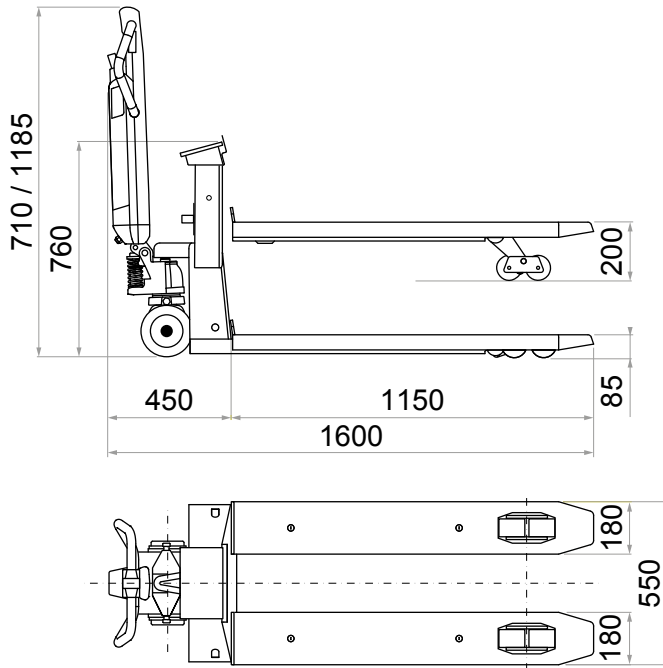

Accessories

- ADDITIONAL BATTERY FOR 24/7 USE
- PC SOFTWARE FOR DATA STORAGE
- BLUETOOTH INTERFACE
- FISCAL MEMORY
- RADIO 2,4 GHz INTERFACE
- USB MEMORY FOR DATA STORAGE
- Wi-Fi

€ For prices and additional accessories see the price list.

PALLET SCALES

“

Weigh pallets wherever you want. Easy to place and remove according to your logistic needs. It occupies the surface only temporarily and can be used together with hand pallet trucks.

”

PALLET SCALES

Pallet scales are the ideal solution for those who want to include weighing in their daily operations with standard pallet trucks or forklifts.

They are compatible with all EUROPALLET / EPAL and are the cheapest solution to integrate weighing into the warehouse.

Thanks to the wheels underneath the pallet scale, you can move it and position it wherever you want.

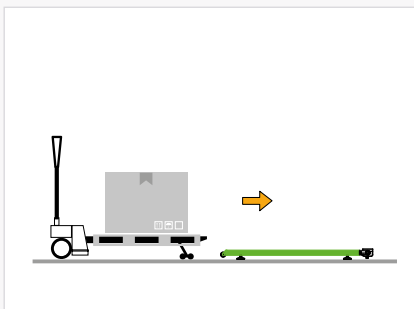

- Place the material to be weighed on the pallet scale

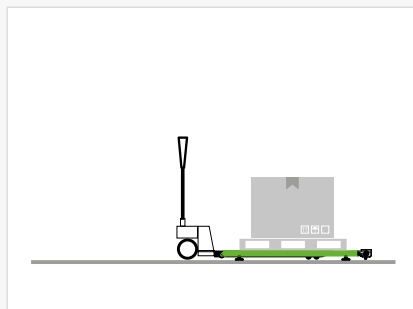

- Start weighing

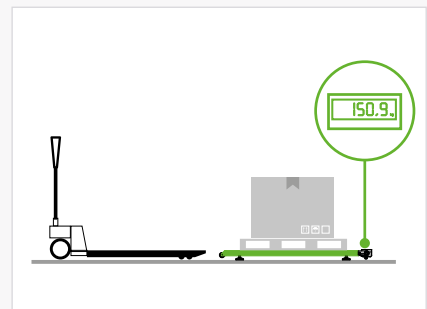

- The weight appears on the display

EPWL

STANDARD

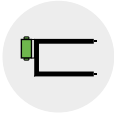

INDICATOR ATTACHED
to the platform

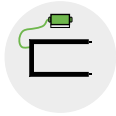

INTEGRATED INDICATOR
cable up to 3 m

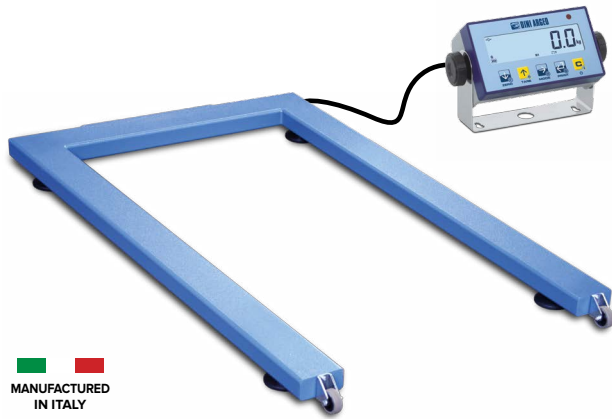

MANUFACTURED
IN ITALY

Fast and accurate pallet scales, ideal for weighing pallets wherever needed.

Choose it because:

- It can be easily moved and installed anywhere
- Easy to use with hand pallet trucks
- Approved for legal-for-trade use

M	Max. Capacity (kg)	d (kg)	e (kg)
	2.000 [600 - 1.500 - 2.000]	0,2 - 0,5 - 1	
M	2.000 [1.000 - 2.000]		0,5 - 1

M Legal for trade.

Other special capacities / resolutions: upon request.
Other special versions: upon request.

Main Functions

- **WEIGHT TOTALISATION**
- **PIECE COUNTING**
- **UNIT CONVERTER:** kg/lb, free conversion factor
- **ZEROING**
- **TARE**
- **PRESET TARE**

Main Features

Indicator	Attached to the pallet scale or wall / column mounted	
Connection cable	3 m	
Display	25 mm LCD backlit display	
Brightness	Adjustable brightness	
IP protection rating	IP54	
Accuracy*	Internal use	± 1 kg
	Legal for trade M	In accordance with Directive 2014/31/EU
Keyboard	5-key waterproof	
Structure	Oven-fire painted steel	
Adjustable feet	As standard	
Wheels	As standard	
Transport handle	As standard	
Load cells	4, in nickel-plated, with IP67 protection	
Auto switch-off	Programmable	
Power supply	4 AA batteries or 12 Vdc, with EU, UK, AU and US power plugs	
Operating time	About 40 h	
Operating temperature range	-10 / +40 °C	
Communication to external devices	Optional Bluetooth	

(*) Weighing of goods on EUROPALLET with distributed load.

Certifications

- 2014/30/EU (EMC)
- 2014/35/EU (LVD)
- 2011/65/EU (RoHS)
- 2014/31/EU (NAWI)

Technical Drawing (mm)

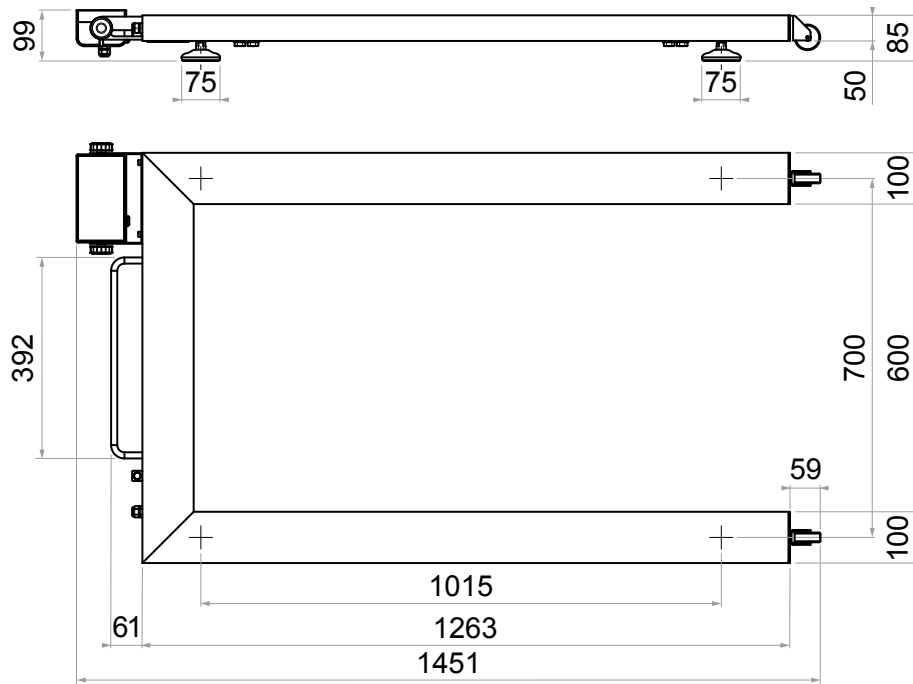

Accessories

- FLOOR COLUMNS
- BLUETOOTH
- PC SOFTWARE FOR DATA STORAGE

€ For Prices and additional accessories see the price list.

EPWLI

STAINLESS STEEL

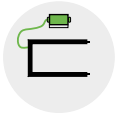

INTEGRATED INDICATOR
cable up to 3 m



 **MANUFACTURED IN ITALY**

A quick and accurate solution to weigh pallets wherever you need it. Fully made in stainless steel, ideal for chemical, pharmaceutical and food industry.

Choose it because:

- It can be easily moved and installed anywhere
- It can be used in outdoor applications or in harsh environments
- Approved for legal-for-trade use

 Max. Capacity (kg)	d (kg)	e (kg)
2.000 [600 - 1.500 - 2.000]	0,2 - 0,5 - 1	
2.000 [1.000 - 2.000]		0,5 - 1

 *Legal for trade.*

Other special capacities / resolutions: upon request.

Other special versions: upon request.

Main Functions

- **WEIGHT TOTALISATION**
- **PIECE COUNTING**
- **UNIT CONVERTER:** kg/lb, free conversion factor
- **ZEROING**
- **TARE**
- **PRESET TARE**

Main Features

Indicator	Wall / Column mounted	
Connection cable	3 m	
Display	25 mm LCD backlit display	
Brightness	Adjustable brightness	
IP protection rating	IP68 weight indicator	
Accuracy*	Internal use	± 1 kg
	Legal for trade 	In accordance with Directive 2014/31/EU
Keyboard	5-key waterproof	
Structure	Stainless steel	
Adjustable feet	As standard	
Wheels	As standard	
Transport handle	As standard	
Load cells	4, in stainless steel, with IP67 protection	
Auto switch-off	5 min, programmable	
Power supply	110 - 240 Vac, with EU power cord**	
Operating temperature range	-10 / +40 °C	
Communication to external devices	Optional Ethernet and Bluetooth	

(*) *Weighing of goods on EUROPALLET with distributed load.*

(**) *UK, AU, US versions: upon request.*

Certifications

- 2014/30/EU (EMC)
- 2014/35/EU (LVD)
- 2011/65/EU (RoHS)
- 2014/31/EU (NAWI)

Technical Drawing (mm)

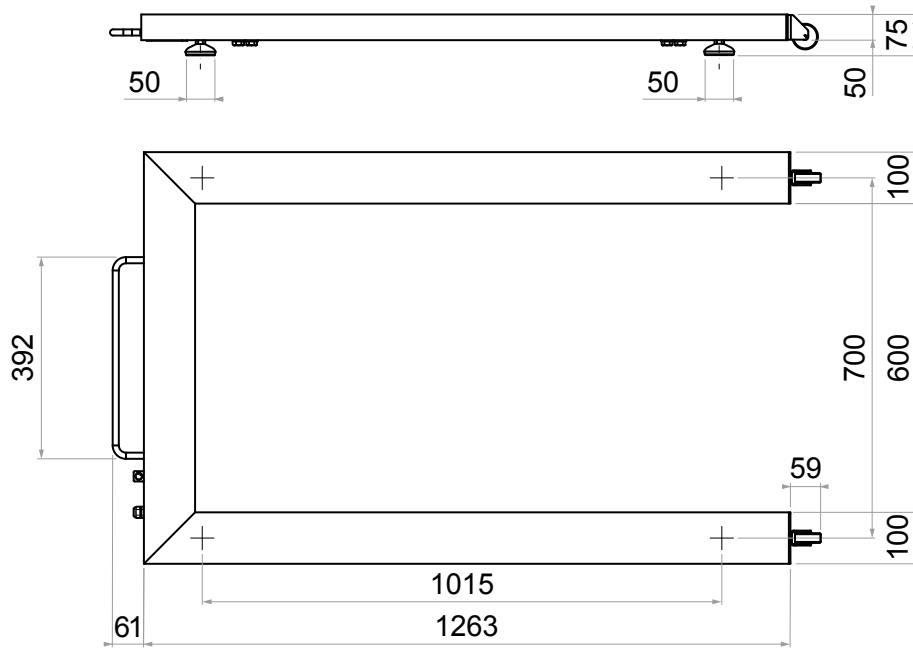

Accessories

- FLOOR COLUMNS
- SUPPORT BRACKETS
- BLUETOOTH INTERFACE
- PC SOFTWARE FOR DATA STORAGE
- ETHERNET

€ For Prices and additional accessories see the price list.



WEIGHING KITS FOR FORKLIFTS AND ELECTRIC PALLET TRUCKS

“

Turn your forklift and electric pallet truck into a mobile scale by installing our dedicated solutions.

”

WEIGHING KITS FOR FORKLIFTS AND ELECTRIC PALLET TRUCKS



WEIGHT INDICATORS

Ideal to read the weight directly in the operator cabin.



LTP

Easy to install and connect to the hydraulic system for overload control and rough weighing.

TWIN FORKS

Weighing forks with wireless technology, ideal for accurate and approved weighing.



LTW

Robust and sturdy weighing module, suitable for heavy duty use.

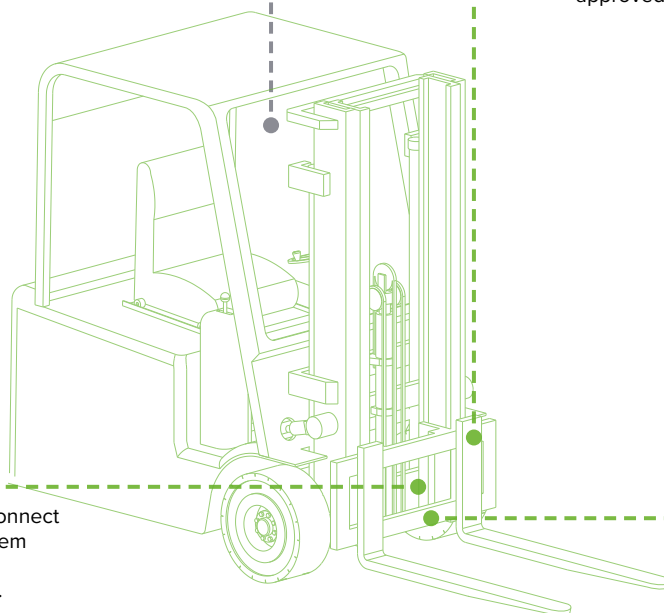

HYDRAULIC PRESSURE SENSOR

WEIGHT INDICATOR



ELP

HYDRAULIC WEIGHING SYSTEM FOR ELECTRIC STACKERS OR ELECTRIC PALLET TRUCKS

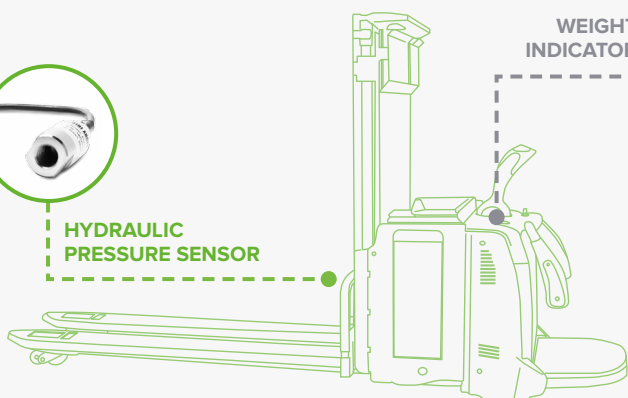



Hydraulic weighing system easy to install on stackers or electric pallet trucks for overload prevention and rough weighing of the handled material. It allows you to weigh the handled material directly on the spot, thus saving time and reducing the traffic in the warehouse.

Choose it because:

- It does not require any mechanical modification
- It does not affect the original manufacturer certification
- It is not subject to accidental impacts



Max. Capacity	d (kg)
Up to 4.000 PSI / 280 BAR	from 1 kg

Main Functions

- ACOUSTIC AND VISUAL INDICATION OF OVERLOADS
- TARE
- PRESET TARE

Main Features

Weight measurement	Specific algorithm for stackers and electric pallet trucks	
Display	25 mm LCD backlit display	
IP protection rating	Sensor	IP65
	Indicator	IP68
Cable length	6 m, shielded connection cable	
Cable protection sheathing	3 m, as standard	
Hydraulic connection	1/4" parallel BSP	
Accuracy	From +/- 0,5% to +/- 5% of capacity, min. 20 kg*	
Keyboard	5-key waterproof	
Max. barycentric shifting	No influence	
Sensor	Nickel-plated steel, with quick connector	
Power supply	5 V, via DC/DC converter (see options)	
Operating temperature range	-10 / +50 °C	
Communication to external devices	Optional Bluetooth and communication port for optional printer	

(*) This value can be influenced by several factors, please refer to the manual for more information.

Certifications

- 2014/30/EU (EMC)
- 2014/35/EU (LVD)
- 2011/65/EU (RoHS)

Technical Drawing | COMPACT Weight Indicator (mm)

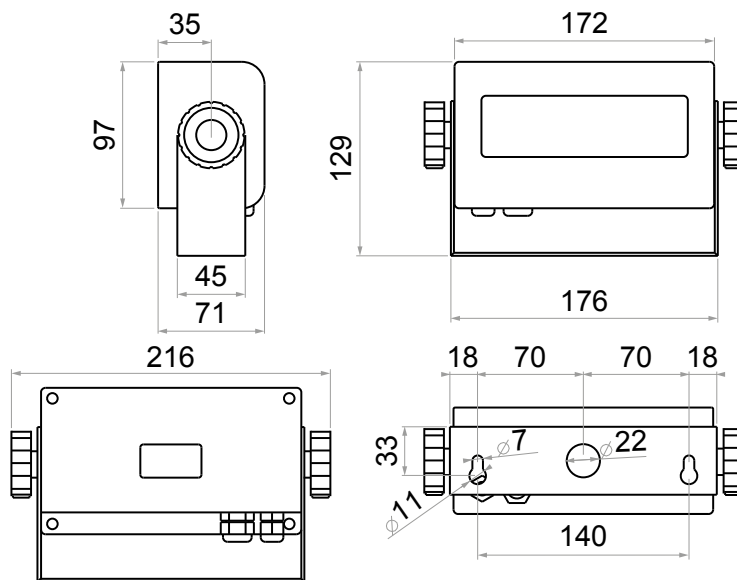

Technical Drawing | Weight Sensor (mm)

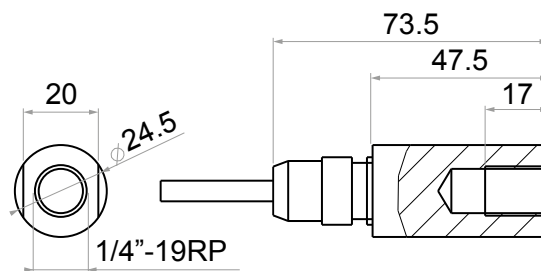

Accessories

- THERMAL PRINTER
- DATE AND TIME
- BLUETOOTH
- FIXING BRACKET FOR INDICATOR

€ For Prices and additional accessories see the price list.



Hydraulic weighing system easy to install on the forklift for overload prevention and rough weighing of the handled material.

It allows you to weigh the handled material directly on the spot, thus saving time and reducing the traffic in the warehouse.

Choose it because:

- It does not reduce the load capacity
- It does not affect the original manufacturer certification
- It is not subject to accidental impacts

Max. Capacity	d (kg)
Up to 4.000 PSI / 280 BAR	from 5 kg



LTP TOOL: Software for weighing system configuration.

Main Functions

- ACOUSTIC AND VISUAL INDICATION OF OVERLOADS
- TARE
- PRESET TARE

Main Features

Weight measurement	Specific algorithm for forklifts	
Display	25 mm LCD backlit display	
IP protection rating	Sensor	IP65
	Indicator	IP68
Cable length	6 m, shielded connection cable	
Cable protection sheathing	3 m, as standard	
Hydraulic connection	1/4" parallel BSP	
Fixing bracket	As standard	
Accuracy	From +/- 0,5% to +/- 5% of capacity, min. 20 kg*	
Keyboard	5-key waterproof	
Max. barycentric shifting	No influence	
Sensor	Nickel-plated steel, with quick connector	
Power supply	5 to 12 V, via DC/DC converter (see options)	
Operating temperature range	-10 / +50 °C	
Communication to external devices	Optional Bluetooth and communication port for optional printer	

(*) This value can be influenced by several factors, please refer to the manual for more information.

Certifications

- 2014/30/EU (EMC)
- 2014/35/EU (LVD)
- 2011/65/EU (RoHS)

Technical Drawing | COMPACT Weight Indicator (mm)

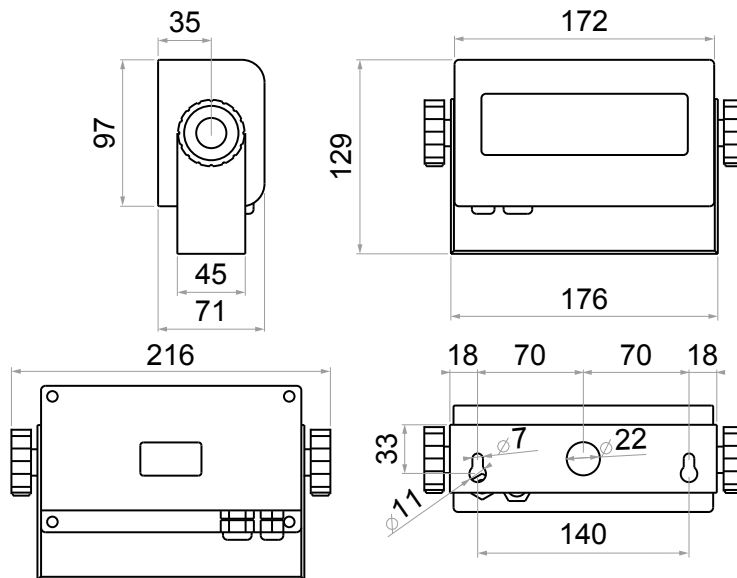

Technical Drawing | Weight Sensor (mm)

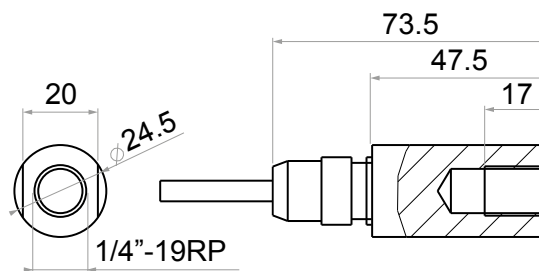

Accessories

- THERMAL PRINTER
- DATE AND TIME
- BLUETOOTH
- FIXING BRACKET FOR INDICATOR

€ For Prices and additional accessories see the price list.

TWIN FORKS

WEIGHING FORKS

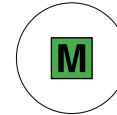

TWIN FORKS represent the easiest weighing solution for forklifts: they simply replace the standard forks transforming your forklift into an accurate approved mobile weighing station. Bluetooth connection, lithium battery and cutting-edge technology to guarantee the best performance.

Choose it because:

- Easy to mount and remove
- Very thin shape with minimum reduction of the lifting capacity
- Approved for legal-for-trade use

M	Max. Capacity (kg)	d (kg)	e (kg) M
*	2.500 [1.000 - 2.500]	1 - 2	2 - 5

Upon request:

- (*) Legal-for-trade-approval M
- Version for FEM2B fork-holder plates
- Version for FEM3A fork-holder plates

Other special versions upon request

Main Functions

- **WEIGHT TOTALISATION**
- **UNIT CONVERTER:** kg/lb, free conversion factor
- **ZEROING**
- **TARE**
- **PRESET TARE**

Main Features

Display	25 mm LCD backlit display	
Brightness	Adjustable brightness	
IP protection rating	Forks	IP66
	Indicator	IP67
Fixing bracket	As standard	
Accuracy	Internal use	± 2 kg
	Legal for trade M	In accordance with Directive 2014/31/EU
Keyboard	5 keys waterproof	
Fork structure	Sturdy painted steel	
Fork connection	FEM2A *(FEM2B and FEM3A upon request)	
Fork weigh	68 kg	
Max. horizontal inclination	± 2° (for legal for trade use only)	
Max. barycentric shifting	25 mm	
Load cells	4, in stainless steel, with IP68 protection	
Max. allowable overload	More than 300% F.S.	
Auto switch-off	5 min, programmable	
Switch-on	Automatic switch-on function, thanks to the movement detector	
Power supply	Forks	Rechargeable lithium battery with Instaplug technology with EU, UK, AU, US power plugs
	Indicator	5 V, from forklift truck
Operating time	Up to 90 h or 24/7 continuous use with optional battery kit	
Operating temperature range	-10 / +40 °C	
Forks communication	Bluetooth technology	
Communication to external devices	Communication port for optional printer	

Certifications

- 2014/30/EU (EMC)
- 2014/35/EU (LVD)
- 2011/65/EU (RoHS)
- 2014/31/EU (NAWI)

Technical Drawing (mm)

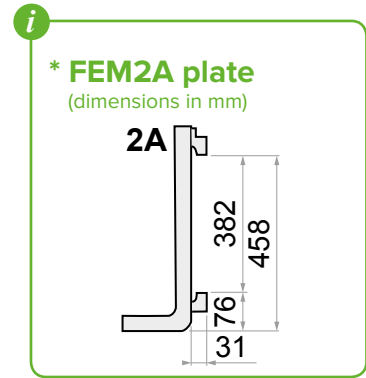
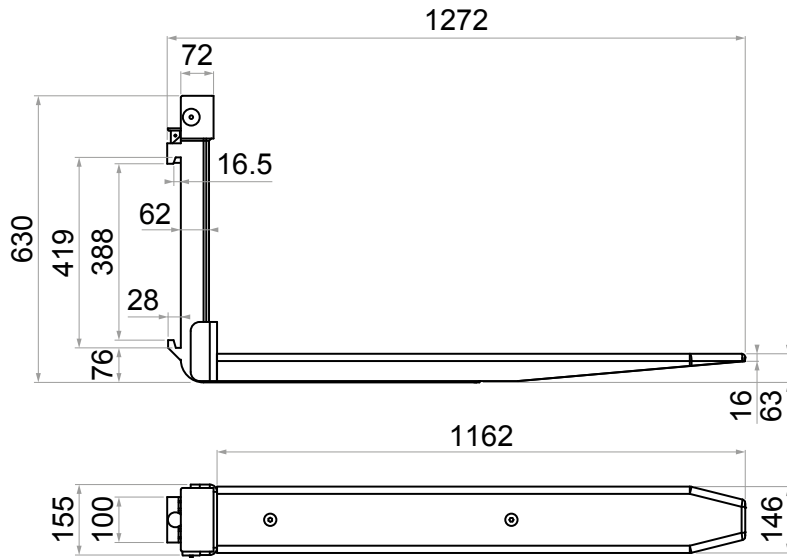

Technical Drawing | COMPACT Weight Indicator (mm)

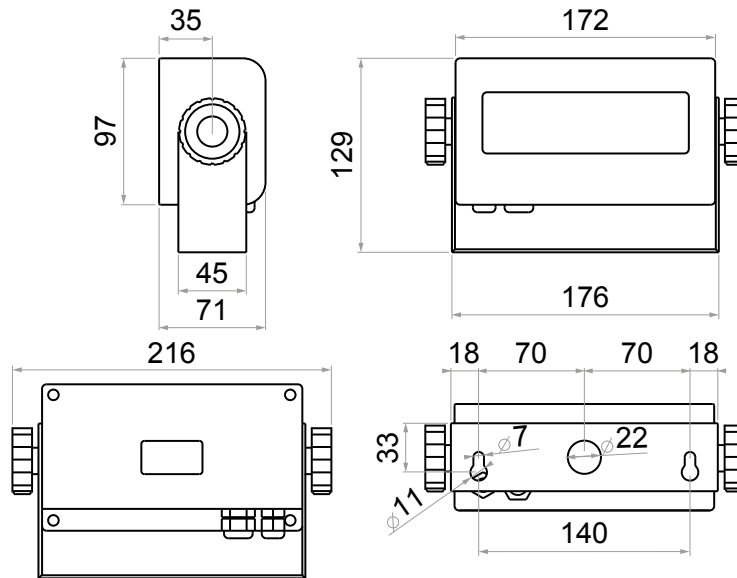

Accessories

- THERMAL PRINTER
- DATE AND TIME
- FIXING BRACKETS FOR INDICATOR

€ For Prices and additional accessories see the price list.

LTW COMPACT

FORKLIFT SCALE



MANUFACTURED IN ITALY

LTW fork-holder plate is added to the existing plates to integrate weighing in a permanent manner while maintaining the possibility of using forks of different lengths depending on the load to be handled. COMPACT indicator for easy installation in the cabin.

Choose it because:

- Suitable for both FEM2A and FEM2B standard forks
- Approved for legal-for-trade use
- Available in wired or wireless version



M	Connection	Max. Capacity (kg)	d (kg)	e (kg) M
*	Wired	1.500 [600 - 1.500]	0,2 - 0,5	1 - 2
*	Wired	2.500 [1.500 - 2.500]	0,5 - 1	2 - 5
*	Bluetooth	1.500 [600 - 1.500]	0,2 - 0,5	1 - 2
*	Bluetooth	2.500 [1.500 - 2.500]	0,5 - 1	2 - 5

Upon request:

- (*) Legal-for-trade-approval M

Other special versions upon request

Main Functions | COMPACT INDICATOR

- **WEIGHT TOTALISATION**
- **PIECE COUNTING**
- **UNIT CONVERTER:** kg/lb, free conversion factor
- **ZEROING**
- **TARE**
- **PRESET TARE**

Main Features

Display	25 mm LCD backlit display	
Brightness	Adjustable brightness	
IP protection rating	Plate	IP67
	Indicator	IP68
Cable length	5 m, extendible, as standard (only for wired version)	
Fixing bracket	As standard	
Accuracy	Internal use	± 0,05% of the max. capacity
	Legal for trade M	In accordance with Directive 2014/31/EU
Keyboard	5 keys waterproof	
Structure	Bearing structure in extra thick sheet steel. Hermetically sealed junction box	
Plate dimensions	Standard FEM class II* - 910 x 407 x 110 mm	
Product weight	184 kg	
Max. horizontal inclination	± 2° (for legal for trade use only)	
Max. barycentric shifting	55 mm	
Load cells	2, in stainless steel, with IP68 protection	
Max. safe overload	More than 300% F.S., with protection nut in case of broken hinges	
Auto switch-off	5 min, programmable	
Power supply	5 V, from the forklift	
Operating temperature range	-10 / +40 °C	
Bluetooth version	Includes Bluetooth emitter integrated on the fork-holder plate with rechargeable battery. Working time: 40 h. Supplied with battery recharger with EU plug.	
Communication to external devices	Wired version	Optional radio-frequency. Wi-Fi or Bluetooth and communication port for optional printer
	Bluetooth version	Communication port for optional printer
Fiscal memory	Optional	
Date and time	Optional	

Certifications

- 2014/30/EU (EMC)
- 2014/35/EU (LVD)
- 2011/65/EU (RoHS)
- 2014/31/EU (NAWI)

Technical Drawing (mm)

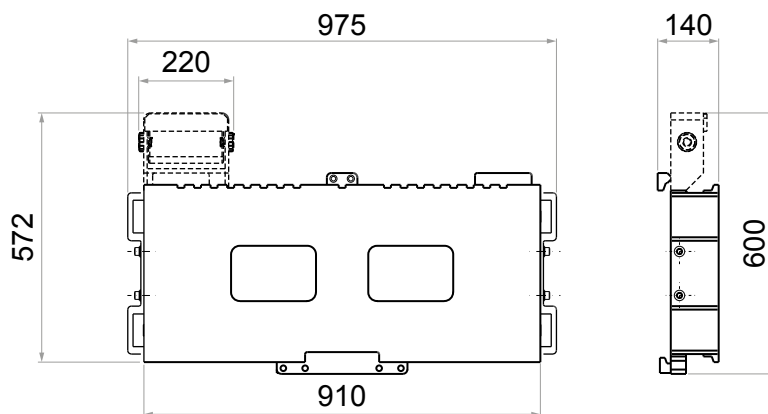

Technical Drawing | COMPACT Weight Indicator (mm)

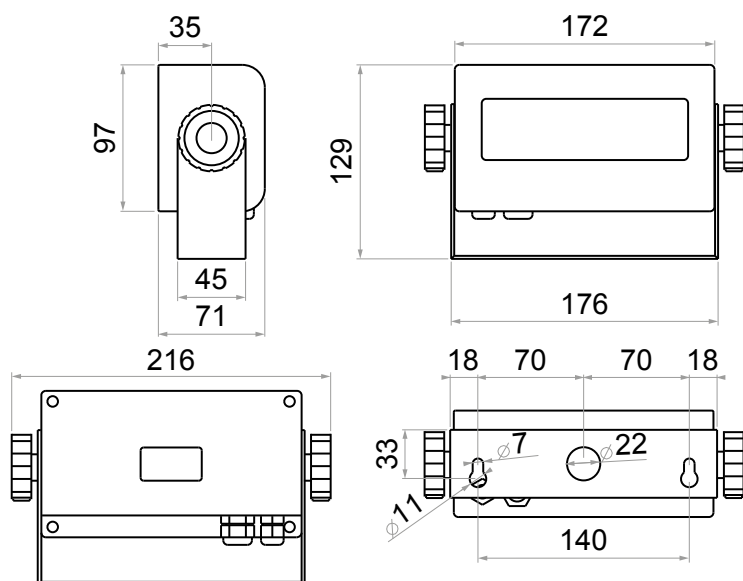

* FEM2A and FEM2B plates (dimensions in mm)

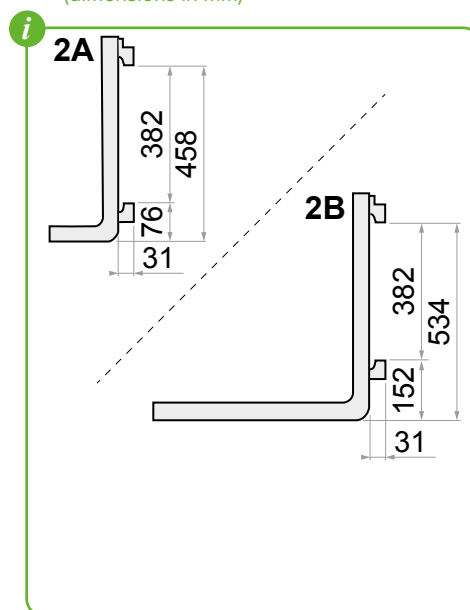

Accessories

- THERMAL PRINTER
- POWER SUPPLY UNIT
- WI-FI
- 2.4 GHz RADIO INTERFACE
- FIXING BRACKET FOR INDICATOR

€ For Prices and additional accessories see the price list.

LTW TOUCH SCREEN

FORKLIFT SCALE

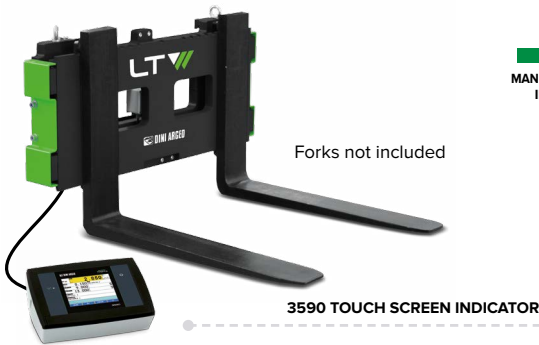

MANUFACTURED IN ITALY

Accurate weighing module for fixed applications and designed to be matched with any type of forks. Fitted with TOUCH SCREEN indicator ideal for communication with the computer systems.

Choose it because:

- Suitable for both FEM2A and FEM2B standard forks
- Approved for legal-for-trade use
- Available in wired or wireless version



M	Connection	Max. Capacity (kg)	d (kg)	e (kg) M
*	Wired	1.500 [600 - 1.500]	0,2 - 0,5	1 - 2
*	Wired	2.500 [1.500 - 2.500]	0,5 - 1	2 - 5
*	Bluetooth	1.500 [600 - 1.500]	0,2 - 0,5	1 - 2
*	Bluetooth	2.500 [1.500 - 2.500]	0,5 - 1	2 - 5

Upon request:

- (*) Legal-for-trade-approval M

Other special versions upon request

Main Functions | TOUCH SCREEN INDICATOR

- **DATABASE MANAGEMENT:** Products, Customers, Suppliers and Tares
- **FULL PROGRAMMABILITY**
- **15 PROGRAMMABLE TEXTS**
- **DATA TRANSFER**
- **FISCAL MEMORY**
- **APPLICATION PROGRAM FOR:** Totalisation, Piece Counting, Dosage
- **NUMERIC IDs**
- **TARE**
- **PRESET TARE**
- **ZEROING**

Main Features

Display	5.7" backlit colour touch screen. Resistive technology	
IP protection rating	Plate	IP67
	Indicator	IP65
Cable length	5 m, extendible, as standard (only for wired version)	
Fixing bracket	As standard	
Accuracy	Internal use	± 0,05% of the max. capacity
	Legal for trade M	In accordance with Directive 2014/31/EU
Keyboard	Touch screen	
Structure	Bearing structure in extra thick sheet steel. Hermetically sealed junction box	
Plate dimensions	Standard FEM class II* - 910 x 407 x 110 mm	
Product weight	184 kg	
Max. horizontal inclination	± 2° (for legal for trade use only)	
Max. barycentric shifting	55 mm	
Load cells	2, in stainless steel, with IP68 protection	
Max. allowable overload	More than 300% F.S, with protection nut in case of broken hinges	
Power supply	12 V, from the forklift	
Operating temperature range	-10 / +40 °C	
Bluetooth version	Includes Bluetooth emitter integrated on the fork-holder plate with rechargeable battery. Working time: 60 h. Supplied with battery recharger with EU plug.	
Communication to external devices	Wired version	Optional radio-frequency, Wi-Fi or Bluetooth and communication port for optional printer
	Bluetooth version	Communication port for optional printer
Fiscal memory	As standard	
Date and time	As standard	
Database	1.000 articles, 300 tares, 200 customers	
Programmability	Free memory spaces for customised application program	
Free alphanumeric texts	15	

Certifications

- 2014/30/EU (EMC)
- 2014/35/EU (LVD)
- 2011/65/EU (RoHS)
- 2014/31/EU (NAWI)

Technical Drawing (mm)

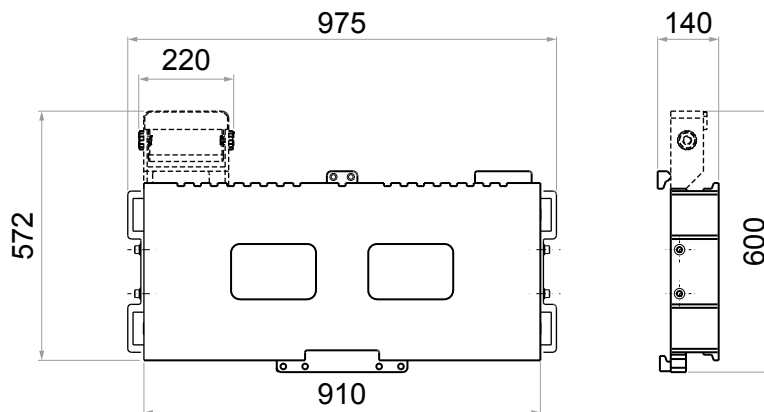

Technical Drawing | TOUCH SCREEN Weight Indicator (mm)

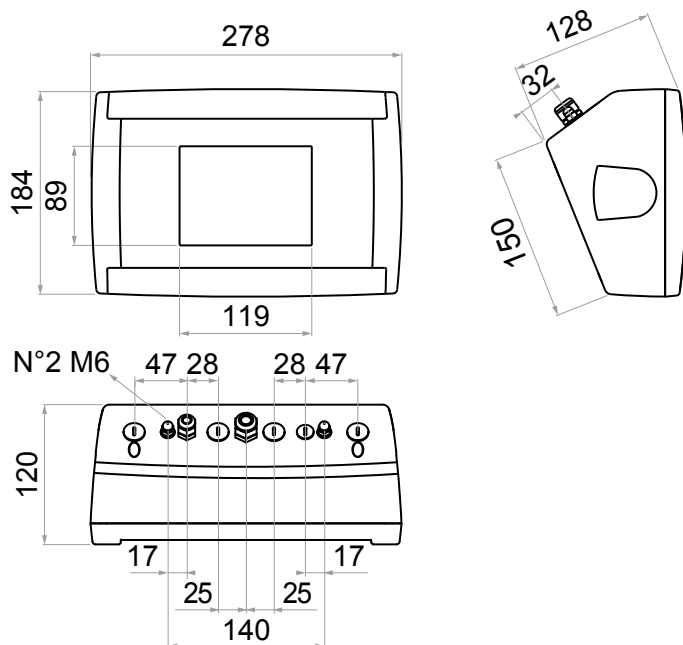

* FEM2A and FEM2B plates (dimensions in mm)

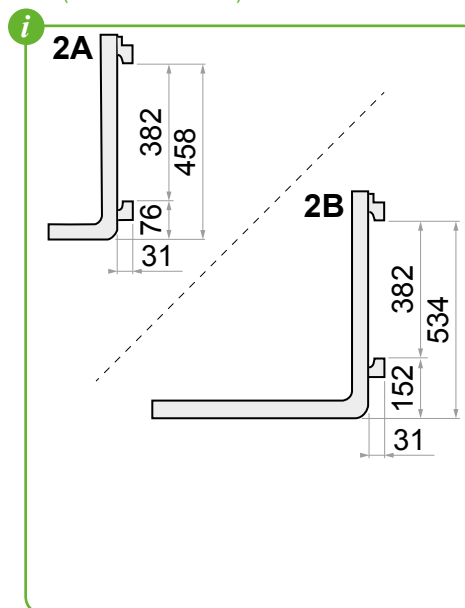

Accessories

- THERMAL PRINTER
- RADIO
- Wi-Fi
- BARCODE READER (only for wired version)
- POWER SUPPLY UNIT
- FIXING BRACKETS FOR INDICATOR

€ For Prices and additional accessories see the price list.

DIMENSIONING SYSTEMS

“

Integrate dimensioning systems in your warehouse to control packages and palletised goods.

”

 **DINI ARCEO**
A RICE LAKE WEIGHING SYSTEMS COMPANY

DIMENSIONING SYSTEMS



IDIMENSION® PLUS

PARCEL DIMENSIONING SYSTEM

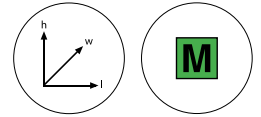

RICE LAKE
WEIGHING SYSTEMS

The Rice Lake Weighing Systems branded dimensioning system is designed to quickly and accurately measure the volume of parcels, envelopes and objects handled by hand, sharing data with the company's computer system in real time.

Choose it because:

- Ideal for speeding up the workflow in intralogistics processes
- Quick and easy installation
- Approved for-legal-for-trade use

M	Camera	Column (m)	Packages dimension (cm)				
			l	h	w	d (cm)	e (cm)
*	Standard	1,2	3 - 100	0 - 60	3 - 60	0,5	0,5
*	Standard	1,5	3 - 120	0 - 70	3 - 80	0,5	0,5
*	4k	1,2	3 - 100	0 - 60	3 - 60	0,5	0,5
*	4k	1,5	3 - 120	0 - 70	3 - 80	0,5	0,5

Upon request:

- (*) Legal-for-trade-approval M

Other special versions: upon request.

Main functions

- OBJECT DIMENSIONING
- DATA TRANSMISSION
- CAMERA

Main Features

Display		7" colour touch screen display
Accuracy	For cartons/boxes	± 5 mm
	For irregular boxes	± 10 mm
Measuring time		0,2 sec.
Detection capability		All opaque packages
I/O ports		USB A port and Ethernet port (Webserver optional)
integration protocols		API and SDK
Power supply		110-240 Vac with US plug as standard*
Weighing Integration	Dini Argeo weight indicators	DFW and 3590 touch screen
	Dini Argeo connectable platforms	T-Series and TE, PB and PBI
	Rice Lake scales	BenchPro Series
Operating temperature range		0 / +40 °C

(*) EU, UK AU versions: upon request.

Certifications

- 2014/35/EU – (LVD)
- 2014/30/EU – (EMC)
- 2011/65/EU – (RoHS)

Technical Drawing (mm)

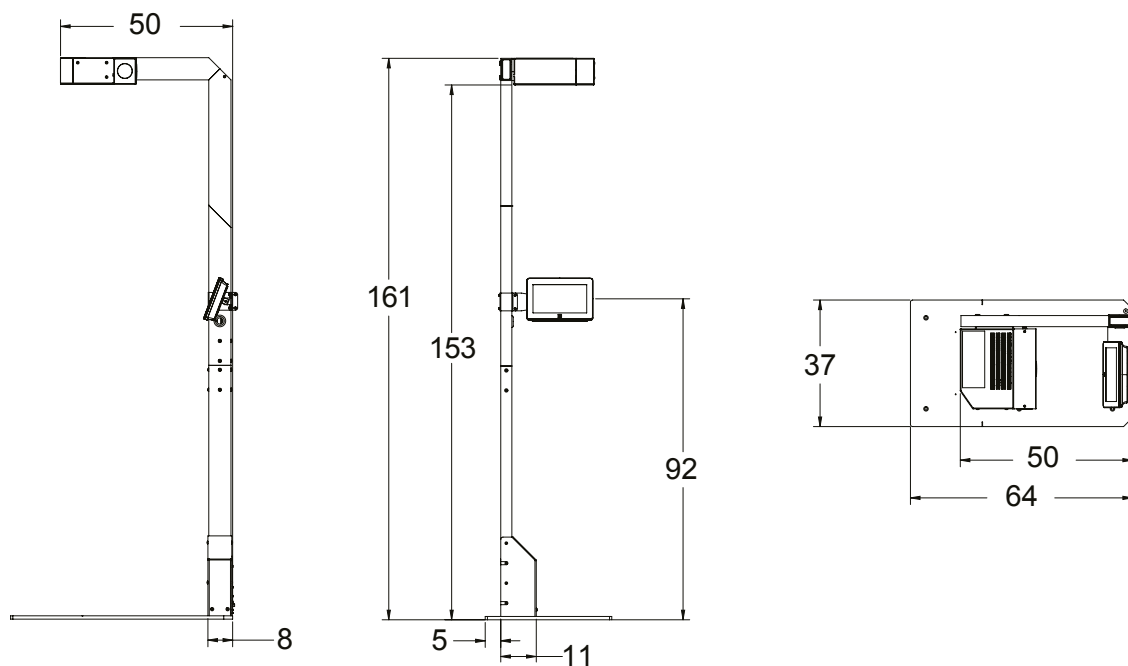

Accessories

- DINI ARGEO WEIGHT INDICATORS AND PLATFORMS
- RICE LAKE BENCHPRO SERIES SCALES
- PRINTERS
- BARCODE READER
- WEBSERVER

€ For Prices and additional accessories see the price list.

IDIMENSION® PLUS XL

FOR OEM SOLUTIONS

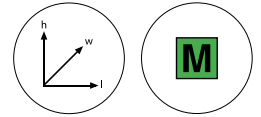

Modular dimensioning system, consisting of a static dimensioning unit and touch screen indicator, ideal for integrating the weight with the volume reading of parcels, cartons and envelopes in pre-shipment handling and sorting machines or lines, or for input and output control.

Choose it because:

- Ideal for integration into OEM systems
- Possibility of connection to scales, indicators and weighing platforms
- Simple and fast installation

Camera	Dimensioning capacity (l x w x h) (cm)	Resolution (cm)
Standard	from 3 x 3 x 0 to 120 x 80 x 80	0,5 - 1
4k	from 3 x 3 x 0 to 120 x 80 x 80	0,5 - 1

Reading capacity and resolution vary with height.
The table shows the available combinations.

Main Functions

- OBJECT DIMENSIONING
- DATA TRANSMISSION
- OBJECT PHOTO STORAGE

Main Features

Display		7" colour touch screen display
Accuracy	For cartons/boxes	± 5 mm
	For irregular boxes	± 10 mm
Measuring time		0,2 sec.
Detection capability		All opaque packages
I/O ports		USB A port and Ethernet port (optional Webserver)
Integration protocols		API and SDK
Power supply		110-240 Vac, with US power socket as standard*
Weighing Integration	Dini Argeo weight indicators	DFW and 3590 touch screen Series
	Dini Argeo connectable platforms	T, TE and PB Series
	Rice Lake scales	Serie BenchPro
Temperatura di utilizzo		0 / +40 °C

(*) EU, UK AU versions: on request.

Certifications

- 2014/35/EU – (LVD)
- 2014/30/EU – (EMC)
- 2011/65/EU – (RoHS)

Technical Drawing (mm)

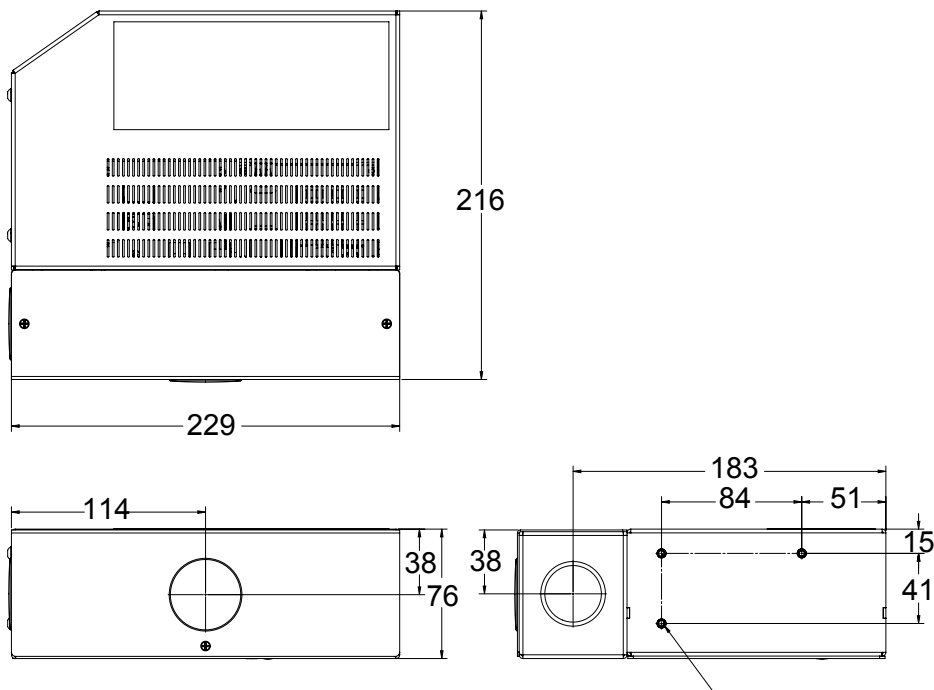

Accessories



- DINI AR GEO WEIGHT INDICATORS AND PLATFORMS
- RICE LAKE BENCHPRO SERIES SCALES
- PRINTERS
- BARCODE READER
- WEBSERVER

€ For Prices and additional accessories see the price list.

NOTES

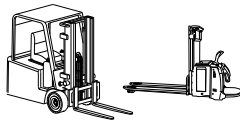
Forklifts
 Electric pallet trucks
 Hydraulic sensor technology
 Load cell technology
 Legal for trade
 Printer
 Wireless connection
 Wired connection
 FEM2A plate
 FEM2B plate
 FEM3A plate



p. 42	•	•			○		•					ELP
p. 44	•	•			○		•	•	○	○		LTP
p. 46	•		•	○	○	•		•	○	○		TWIN FORKS
p. 48	•		•	○	○	•	•	•	•	○		LTPW COMPACT
p. 50	•		•	○	○	•	•	•	•	○		LTPW TOUCH

WEIGHING KITS FOR FORKLIFTS
AND ELECTRIC PALLET TRUCKS

Plug & Play Solution
 Modules for integration
 with scales
 Camera 4K

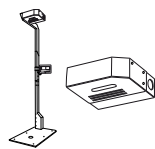

p. 52	•				○	•					IDIMENSION® PLUS
p. 54		•			○	•					IDIMENSION® PLUS XL

DIMENSIONING SYSTEM MS

OPEN TO SEE THE INDEX

DISCOVER
OUR FULL RANGE OF PRODUCTS



Dini Argeo dealer network:
over 3500 partners
in more than 85 countries across the world

“YOUR WORLDWIDE PARTNER
FOR WEIGHING”



A RICE LAKE WEIGHING SYSTEMS COMPANY

COMPANY HEADQUARTERS

Via Della Fisica, 20
41042 Spezzano di Fiorano Modena • Italy
Tel. +39.0536 843418

SERVICE ASSISTANCE

Via Dell'Elettronica, 15
41042 Spezzano di Fiorano Modena • Italy
Tel. +39.0536 921784

OTHER DINI ARGEO LOCATIONS

DINI ARGEO WEIGHING INSTRUMENTS Ltd
China

DINI ARGEO UK Ltd
United Kingdom

DINI ARGEO FRANCE sarl
France

DINI ARGEO GMBH
Germany

DINI ARGEO OCEANIA
Australia

WHY CHOOSE DINI ARGEO?



WORLDWIDE SERVICE AND SHIPPING

International group
with offices in America,
Europe, India, China,
Mexico and Oceania,
over 900 employees
and a network of
specialised partners
in 130 countries
worldwide.



FAST SHIPPING

Dini Argeo always
keeps complete
systems in stock that
can be shipped quickly.



MADE IN ITALY

Dini Argeo weighing
solutions are made in
Italy and guarantee
the highest quality
standards.

SALES SERVICE AND TECHNICAL ASSISTANCE

Mod **LOGIW-CEN**

P/N



LOGIW-CEN

Sn



NOSN



LOGIW-CEN/NOSN

Rev. 01.01.2023