

# Forklift / Pallet Jack Scales

---

## TABLE OF CONTENTS

|   |            |
|---|------------|
| <b>CLS Series Class II</b> .....                      | <b>424</b> |
| <i>Forklift Scale</i>                                 |            |
| <b>CLS Series Class II</b> .....                      | <b>425</b> |
| <i>Forklift Scale with Mobile Printer</i>             |            |
| <b>CLS Series Class III</b> .....                     | <b>426</b> |
| <i>Forklift Scale</i>                                 |            |
| <b>CLS Series Options</b> .....                       | <b>427</b> |
| <i>Forklift Scale</i>                                 |            |
| <b>CLS Series Dimensions</b> .....                    | <b>428</b> |
| <i>Forklift Scale</i>                                 |            |
| <b>CLS-680</b> .....                                  | <b>429</b> |
| <i>Forklift Scale Display</i>                         |            |
| <b>CLS-920i®</b> .....                                | <b>430</b> |
| <i>Forklift Scale Display</i>                         |            |
| <b>VIRTUj<sup>®3</sup></b> .....                      | <b>431</b> |
| <i>PC-Based Program for CLS Series Forklift Scale</i> |            |
| <b>RL-HPJ</b> .....                                   | <b>432</b> |
| <i>Hand Pallet Jack Scale</i>                         |            |

*Product names, logos, brands and other trademarks featured or referred to within this publication are the property of their respective trademark holders.*

# CLS Series Class II

Forklift Scale



## Approvals



Measurement  
Canada  
Approved

## Part Number/Price

| Part #   | Capacity     | Description  | Est. Weight | Price       |
|--|--------------|--|-------------|-------------|
| <b>Class II, CLS-680, NTEP Certified</b>                     |              |  |             |             |
| 201300   | 5,000 × 5 lb | 34 in W, 16 in H forklift carriage (36 in W with flexures), 9 to 36 VDC            | 530 lb      | \$9,140.00  |
| 201302   | 5,000 × 5 lb | 34 in W, 16 in H forklift carriage (36 in W with flexures), 9 to 36 VDC, cableless | 545 lb      | \$11,190.00 |
| <b>Class II, CLS-920i, NTEP Certified</b>                    |              |  |             |             |
| 223214   | 5,000 × 5 lb | 34 in W, 16 in H forklift carriage (36 in W with flexures), 9 to 36 VDC            | 540 lb      | \$10,390.00 |
| 226201   | 5,000 × 5 lb | 34 in W, 16 in H forklift carriage (36 in W with flexures), 9 to 36 VDC, cableless | 565 lb      | \$12,440.00 |
| <b>Class II, VIRTUi<sup>3</sup> M Series, NTEP Certified</b> |              |  |             |             |
| 194714**   | 5,000 × 5 lb | 34 in W, 16 in H forklift carriage (36 in W with flexures)                         | 525 lb      | \$8,470.00  |
| <b>Class II, VIRTUi<sup>3</sup> IM Series</b>                |              |  |             |             |
| 191748**   | 5,000 × 5 lb | 34 in W, 16 in H forklift carriage (36 in W with flexures)                         | 525 lb      | \$9,020.00  |

|  |              |  |        |             |
|--|--------------|--|--------|-------------|
| <b>Class II, CLS-680 with Measurement Canada Approval</b>  |              |  |        |             |
| 214091   | 4,500 × 5 lb | 34 in W, 16 in H forklift carriage (36 in W with flexures), 9 to 36 VDC            | 530 lb | \$9,140.00  |
| 208269   | 4,500 × 5 lb | 34 in W, 16 in H forklift carriage (36 in W with flexures), 9 to 36 VDC, cableless | 545 lb | \$11,190.00 |
| <b>Class II, CLS-920i with Measurement Canada Approval</b> |              |  |        |             |
| 215114   | 4,500 × 5 lb | 34 in W, 16 in H forklift carriage (36 in W with flexures), 9 to 36 VDC            | 540 lb | \$10,390.00 |
| 216947   | 4,500 × 5 lb | 34 in W, 16 in H forklift carriage (36 in W with flexures), 9 to 36 VDC, cableless | 565 lb | \$12,440.00 |

\*\*Weight indication device (PC/tablet) is not included; consult factory to verify compatibility with your device

## Standard Features

### Scale Carriage

- 34 in (Class II), 5,000 × 5 lbs, NTEP Certified
- 1-1/2 in thick front and back painted steel plates coupled by four flexures
- Top cleats are welded, pinned and bolted
- Welded centering pin
- Two 5,000 lb S-beam load cells
- iQUBE<sup>2</sup>® junction box with inclinometer
- Molded coiled cable, up to 15 ft uncoiled

### Options

- 28 in (Class II), 5,000 × 5 lb, NTEP Certified
- 18 to 72 VDC, CLS-680

### Presale Requirements

- Provide completed forklift questionnaire for quotation
- Compatible with most Class II forklift attachments, consult factory

### Installation Recommendations

- When installing a forklift scale on an electric forklift, static discharge protection must be present on the forklift and install a chassis mount power conditioner to protect scale electronics.
- When installing a forklift scale, OSHA requires the end user to de-rate the lift capacity of the forklift.

## Specifications

### Warranty:

Two-year limited

### Approvals:

NTEP 06-074

Measurement Canada AM-5893

# CLS Series Class II

Forklift Scale with Mobile Printer



Zebra ZQ630

CLS-680

## Standard Features

- Preconfigured for use with Zebra ZQ630 Printer, CLS-680 Mode 608
- Package includes:
  - CLS -680 scale assembly
  - Zebra ZQ630 thermal printer
  - Printer mount kit
  - DC power supply for printer
  - Serial and adapter cables from indicator to printer

## Approvals



## Part Number/Price

| Part #  | Capacity     | Description  | Est. Weight | Price       |
|---|--------------|--|-------------|-------------|
| <b>Class II, CLS-680, Zebra Printer, NTEP Certified</b> |              |  |             |             |
| 207505  | 5,000 × 5 lb | 34 in W, 16 in H forklift carriage (36 in W with flexures) with Zebra ZQ630 Printer, wired, 12 to 24 VDC     | 545 lb      | \$11,270.00 |
| 206446  | 5,000 × 5 lb | 34 in W, 16 in H forklift carriage (36 in W with flexures) with Zebra ZQ630 Printer, 12 to 24 VDC, cableless | 570 lb      | \$13,320.00 |
| 210982  | 5,000 × 5 lb | 34 in W, 16 in H forklift carriage (36 in W with flexures) with Zebra ZQ630 Printer, wired, 18 to 60 VDC     | 545 lb      | \$11,660.00 |
| 208619  | 5,000 × 5 lb | 34 in W, 16 in H forklift carriage (36 in W with flexures) with Zebra ZQ630 Printer, 18 to 60 VDC, cableless | 570 lb      | \$13,710.00 |

FORKLIFT / PALLET JACK SCALES

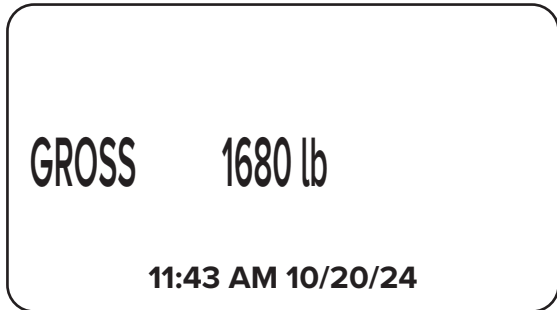

Gross label

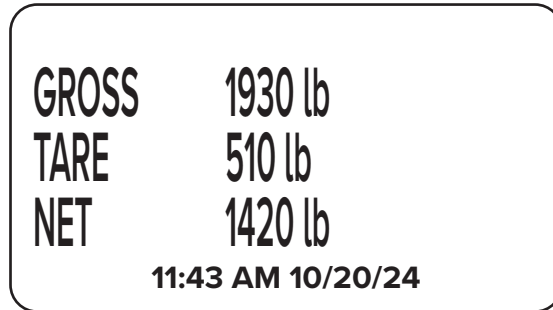

Net label

# CLS Series Class III

Forklift Scale



## Standard Features

### Scale Carriage

- 38 in (Class III), 8,000 × 5 lbs, non-NTEP
- 1-1/2 in thick front and back painted steel plates coupled by four flexures
- Top cleats are welded, pinned and bolted
- Welded centering pin
- Two 5,000 lb S-beam load cells
- iQUBE<sup>2</sup>® junction box with inclinometer
- Molded coiled cable, up to 15 ft uncoiled

### Presale Requirements

- Provide completed forklift questionnaire for quotation
- Compatible with most Class III forklift attachments, consult factory

### Installation Recommendations

- When installing a forklift scale on an electric forklift, static discharge protection must be present on the forklift and install a chassis mount power conditioner to protect scale electronics.
- When installing a forklift scale, OSHA requires the end user to de-rate the lift capacity of the forklift.

## Specifications

### Warranty:

Two-year limited

## Part Number/Price

| Part #   | Capacity     | Description  | Est. Weight | Price       |
|--|--------------|--|-------------|-------------|
| <b>Class III, CLS-680, Non-NTEP Certified</b>  |              |  |             |             |
| 212521   | 8,000 × 5 lb | 38 in W, 20 in H forklift carriage, 9 to 36 VDC            | 985 lb      | \$13,140.00 |
| 214092   | 8,000 × 5 lb | 38 in W, 20 in H forklift carriage, 9 to 36 VDC, cableless | 990 lb      | \$15,190.00 |
| <b>Class III, CLS-920i, Non-NTEP Certified</b> |              |  |             |             |
| 219975   | 8,000 × 5 lb | 38 in W, 20 in H forklift carriage, 9 to 36 VDC            | 990 lb      | \$14,390.00 |
| 214093   | 8,000 × 5 lb | 38 in W, 20 in H forklift carriage, 9 to 36 VDC, cableless | 1,005 lb    | \$16,440.00 |

FORKLIFT /  
PALLET JACK SCALES

## CLS Indicator

### CLS-680 (page 429)

The CLS-680 was designed from the ground-up specifically for forklift applications. With a machined aluminum anodized enclosure, the CLS-680 is ideal for demanding, general-purpose forklift applications. Its compact size is attached with a RAM® mount for flexible positioning and minimal obstruction. Additional features include rounded corners, vibration protection and surge suppression.

- Six-digit, seven-segment LED display
- Battery backed time and date
- On/off power switch
- 9 to 26 VDC or 18 to 72 VDC power supply
- Cabled or cableless
- RS-232 serial port
- Wi-Fi
- Bluetooth®

## CLS Indicator

### CLS-920i (page 430)

The CLS-920i incorporates the flexibility, intelligence and programmability of the 920i in a smaller enclosure with a DC power supply for use on forklifts. The standard program offers weight indication, configuration, calibration and diagnostics specific to the CLS. Customize it for your application with an optional user program.

- Painted mild steel enclosure
- Backlit graphical LCD display
- Battery backed time and date
- On/off power switch
- 9 to 36 VDC power supply
- Cabled or cableless
- Two available RS-232 ports for added options
- Optional Wi-Fi
- Optional Bluetooth®

## CLS Virtual Solution

### VIRTUi<sup>3</sup> (page 431)

Weight data is displayed on a device using VIRTUi<sup>3</sup> software, creating a virtual indicator. The CLS connects to your device using RS-232, USB or Bluetooth®. Choose between the CLS-M or CLS-IM configuration for static or in-motion use.

- Weight indication device (PC/tablet) is not included
- Consult factory to verify compatibility with your device
- Bluetooth® connection available
- USB connection available

## Cableless

The cableless option removes the coiled communications/power cable between the scale and the indicator. A rechargeable battery is secured to the scale and it powers the scale and the paired wireless modules provide communication.

- 802.15 wireless interface
- Lithium-ion battery and charger
- On/off power switch
- Battery life: 24 hours of constant use
- Battery recharge time: 8 hours to fully recharge
- Reinforced battery box welded to top cover

## Wi-Fi

Wi-Fi is a standard feature for the CLS-680 and is available as a factory installed option for the CLS-920i.

- Wireless LAN card 802.11 b/g
- Range: Up to 328 ft indoors
- Operating frequency: ISM 2.4 GHz

## Bluetooth®

Bluetooth® communication is a standard feature for the CLS-680 and is available as an external option for the CLS-920i. It is also available in a communications/power box for the virtual solution.

## Forklift Capacity Derating

During the initial scale installation, remind the customer that they must have an updated ID plate on the forklift stating the new lifting capacity and center of gravity information. This is required per OSHA rules and regulations.

|   | 28 In   | 34 In   | 38 In    |
|---|---------|---------|----------|
| Vertical center of gravity (VCG) of scale =   | 8.06 in | 8.06 in | 10.15 in |
| Horizontal center of gravity (HCG) of scale = | 2.09 in | 2.09 in | 2.83 in  |
| Effective thickness (ET) of scale =           | 4.55 in | 4.55 in | 6.06 in  |
| Weight of scale =                             | 392 lb  | 420 lb  | 987 lb   |

# CLS Series Dimensions

Forklift Scale

## Dimensions

| CLS Class II    |                   |   |                   |
|-----------------|-------------------|---|-------------------|
| 28 in, 5,000 lb |                   |   |                   |
| A               | 28.00 in (711 mm) | E | 19.50 in (495 mm) |
| B               | 30.00 in (762 mm) | F | 4.49 in (114 mm)  |
| C               | 16.00 in (406 mm) | G | 21.80 in (554 mm) |
| D               | 16.29 in (414 mm) | H | 28.24 in (717 mm) |
| 34 in, 5,000 lb |                   |   |                   |
| A               | 34.00 in (864 mm) | E | 19.50 in (495 mm) |
| B               | 36.00 in (914 mm) | F | 4.49 in (114 mm)  |
| C               | 16.00 in (406 mm) | G | 21.80 in (556 mm) |
| D               | 16.29 in (413 mm) | H | 34.24 in (870 mm) |

## Dimensions

| CLS Class III   |                    |   |                   |
|-----------------|--------------------|---|-------------------|
| 38 in, 8,000 lb |                    |   |                   |
| A               | 38.00 in (965 mm)  | E | 24.50 in (622 mm) |
| B               | 40.00 in (1016 mm) | F | 6.04 in (153 mm)  |
| C               | 20.00 in (508 mm)  | G | 26.68 in (678 mm) |
| D               | 20.15 in (512 mm)  | H | 38.00 in (965 mm) |

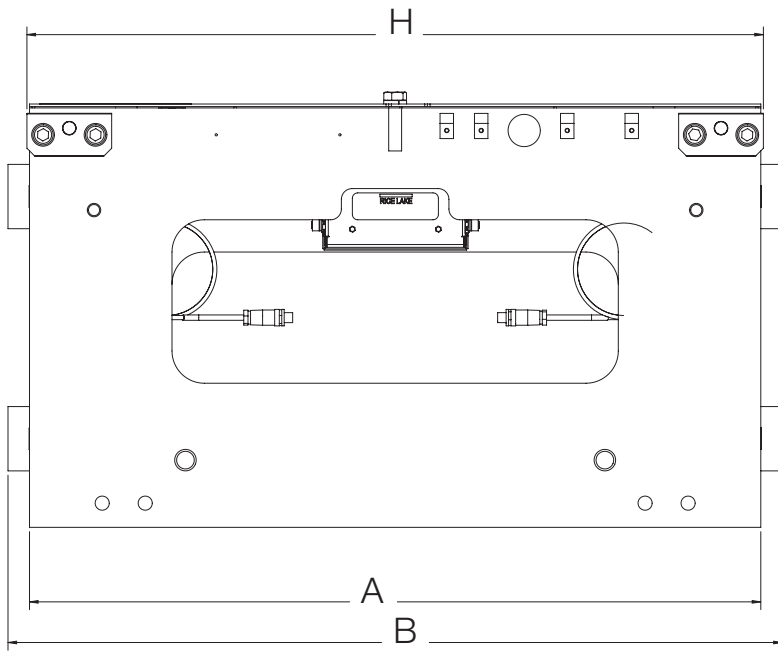

Front view

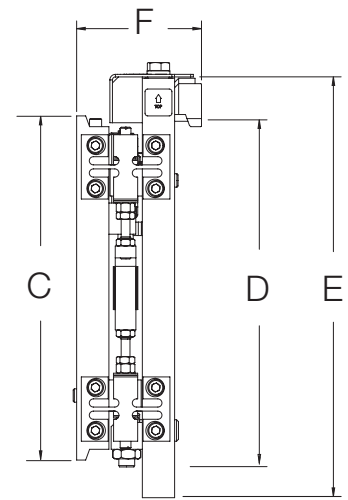

Side view

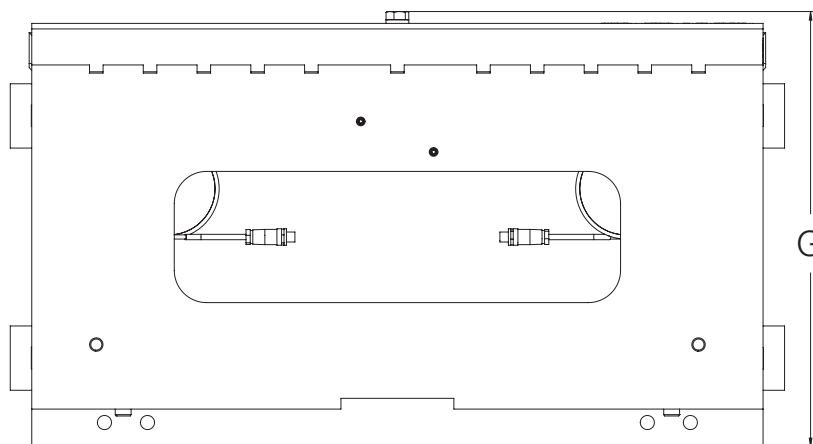

Rear view

**FORKLIFT /  
PALLET JACK SCALES**



## Standard Features

- LED display
- Battery backed time and date
- Full numeric keypad
- Numeric keyed entry allowed for tare
- Formattable tickets
- CLS user modes
- Machined aluminum enclosure with rounded corners
- Wi-Fi standard
- Bluetooth® standard
- Embedded antenna
- RAM® style mount ability
- M16 connector, CLS scale connection
- M12 connector, RS-232
- Power cable connector
- PreVent™ breather vent
- Illuminated power switch

## Options

- Cableless interface to CLS with Zigbee module
- RAM style mounts
- Molded M12 serial cables

## Specifications

### Power:

DC voltages: 9 to 36 VDC or 18 to 72 VDC

### Communication Ports:

Two RS-232 full duplex, one reserved for CLS Bluetooth® SSP

Wi-Fi: Wireless 802.11 b/g/n 2.5 GHz

Zigbee, reserved for CLS cableless option

### Annunciators:

10 LED

### Display:

Six-digit, 0.5 in tall, seven-segment digits

### Keys/Buttons:

Flat membrane panel, tactile feel (18 buttons)

### Temperature:

Certified: 14 °F to 104 °F (-10 °C to 40 °C)

Industrial: 14 °F to 122 °F (-10 °C to 50 °C)

### Dimensions:

(L × W × H)

6.5 × 5.2 × 3.3 in

(165 × 132 × 84 mm)

### Estimated Weight:

3.7 lb (1.7 kg)

### Material:

Machined aluminum enclosure, anodized finish

### EMC Immunity:

EN 50082 Part 2 IEC 61000-4-2,3,4,5,6,8 and 11

### Warranty:

Two-year limited

### Approvals:

NTEP 21-092, Class III/IIIL, 5,000d

## Approvals



## Part Number/Price

| Part # | Description                     | Price      |
|--------|---------------------------------|------------|
| 206439 | CLS-680 indicator, 9 to 36 VDC  | \$1,310.00 |
| 204239 | CLS-680 indicator, 18 to 72 VDC | \$1,590.00 |

## Dimensions

| CLS-680 |                 |
|---------|-----------------|
| A       | 5.2 in (132 mm) |
| B       | 6.5 in (165 mm) |
| C       | 3.3 in (84 mm)  |
| D       | 2.5 in (64 mm)  |

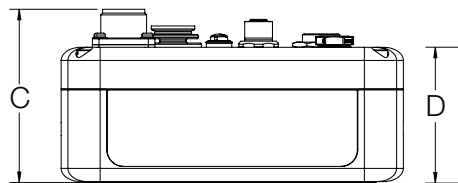
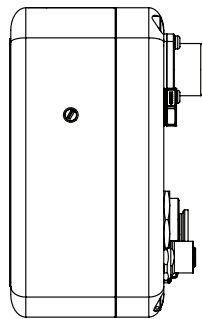
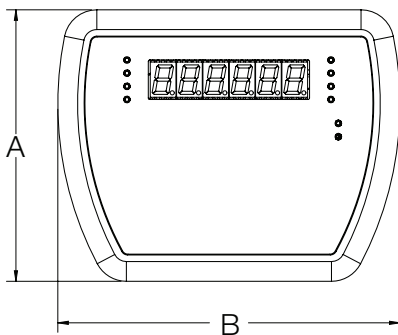

# CLS-920i®

Forklift Scale Display



## Approvals



Measurement  
Canada  
Approved

## Part Number/Price

| Part # | Description  | Price      |
|--------|--|------------|
| 162112 | CLS-920i indicator with mounting brackets, 9 to 36 VDC | \$3,200.00 |

## Dimensions

| CLS-920i |                  |
|----------|------------------|
| A        | 9.54 in (242 mm) |
| B        | 7.20 in (183 mm) |
| C        | 9.71 in (247 mm) |
| D        | 5.82 in (148 mm) |

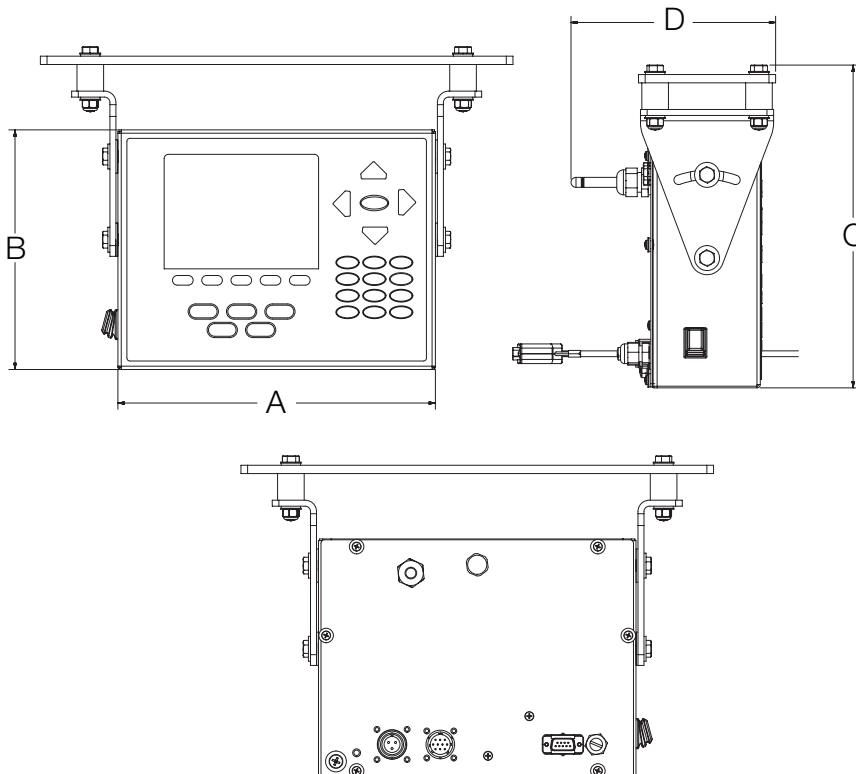

## Standard Features

- LCD display
- Standard program
  - Weight indication
  - Configuration
  - Calibration
  - Diagnostics
- Front panel calibration
- On/Off switch to conserve forklift battery life
- Painted mild steel enclosure
- Two-piece top cage indicator mounting assembly with vibration mounts
- Two available RS-232 ports for added options of scanner, Wi-Fi or printer
- 9 to 36 VDC power supply for use on gas powered or electric forklifts

*Note: For custom user program, please contact the factory*

## Specifications

### Power:

Line voltage: 9 to 36 VDC, DC input

### Power Consumption:

1.5 A max fused at 5.0

### Temperature:

Certified: 14 °F to 104 °F (-10 °C to 40 °C)

Operating: 14 °F to 122 °F (-10 °C to 50 °C)

### Wireless LAN Option:

Contains FCC ID: R68WIPORATG

Range: Up to 328 ft indoors

Operating frequency: ISM 2.4 GH

### Warranty:

Two-year limited

### Approvals:

NTEP 06-074, 5,000 lb only, Class III, 1,000d

Measurement Canada AM-5893, Class III





### Standard Features

- Virtual front panel consists of display and two or three button keypad
- Printer port configuration, serial or TCP/IP
- Provides CLS configuration screen
- Supports CLS diagnostics
- Weight indication screen
- Weight display
- Zero, print and in-motion clear buttons
- Capacity, resolution, units, motion and center of zero status annunciators
- Unit ID
- Configuration, calibration and diagnostics menus
- VIRTU<sup>i</sup> Mini, minimized weight display screen
- Scale test menu

### Specifications

#### Minimum System Requirements:

Windows® 8.1 or greater  
Serial port connection to CLS Series forklift scale  
Additional serial ports are required for connections to printers/remote displays 100 MB space needed  
8 GB or greater RAM

#### Annunciators:

Units, capacity, resolution, motion, center of zero

#### Approvals:

NTEP 04-058

### Approvals



### Part Number/Price

| Part # | Description                 | Price    |
|--------|-----------------------------|----------|
| 188745 | VIRTU <sup>i</sup> software | \$495.00 |



### QR Code Application Software

- Windows 10 or greater
- Interfaces to the Virtui<sup>3</sup> Server to generate a QR Model 2 Bar Code that is scannable
- Requires installation of Virtui<sup>3</sup> (purchased separately)

### Part Number/Price

| Part # | Description                  | Price    |
|--------|------------------------------|----------|
| 226345 | QR Code application software | \$395.00 |

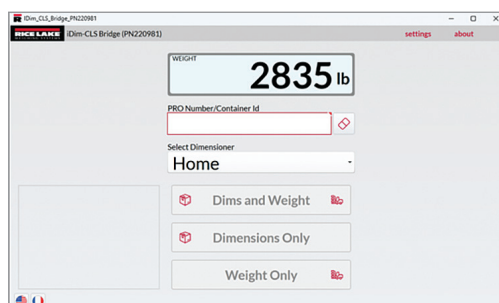

### Middleware Forklift/Dimensioning Software

- Windows 10 or greater
- Connection between iDimSS and indicators

### Part Number/Price

| Part # | Description                               | Price    |
|--------|---|----------|
| 220981 | Middleware forklift/dimensioning software | \$595.00 |

# RL-HPJ

Hand Pallet Jack Scale



## Standard Features

- Steering wheels and double loading polyurethane rollers
- Four stainless steel IP68 load cells
- Weight indicator in IP65 stainless steel water-resistant enclosure
- Configuration, calibration and diagnostics from keyboard
- Rechargeable battery mounted on the pallet jack
- Zero and tare functions
- Net/Gross and lb/kg conversion
- Accumulation
- Formulation
- ± Checkweighing
- Percentage weighing
- Counting (Max. resolution of 1,500,000 divisions)
- Peak hold
- Includes a 115 VAC 50/60 Hz battery charger

## Specifications

### Battery Life:

80 hours of continuous use or one month of non-continuous use

### Display:

1 in (25 mm) LCD display high contrast digits

### Capacity:

Maximum lifting capacity 5,000 lb

### Accuracy:

± 0.1% of the maximum capacity

### Keys/Buttons:

17 functional keys

### Temperature:

Operating:  
14 °F to 104 °F (-10 °C to 40 °C)

### Material:

Heavy-gauge steel with a durable powder coat finish

### Fork Dimensions:

48.75 × 26.75 × 3.125 in  
(1240 × 680 × 80 mm)

### Weight:

Approx. 360 lb (163 kg)

### Warranty:

One-year limited

## Part Number/Price

| Part # | Description   | Est. Weight | Price      |
|--------|---|-------------|------------|
| 183592 | Pallet jack scale, RL-HPJ, 5,000 × 1 lb               | 360 lb      | \$2,495.00 |
| 220672 | Pallet jack scale, RL-HPJ, 5,000 × 1 lb, with printer | 365 lb      | \$2,920.00 |

## Options/Accessories

| Part # | Description   | Price    |
|--------|---|----------|
| 215143 | Power supply, 7.2 VDC, 3 A SLA battery charger        | \$132.00 |
| 215142 | Battery, rechargeable                                 | \$158.00 |
| 182053 | Printer paper roll, 57 mm × 30 m, 12 mm core 51 mm OD | \$3.00   |

NOTE: See replacement parts page to detail correct part numbers for previous generations

## Dimensions

| RL-HPJ |                     |   |                   |
|--------|---------------------|---|-------------------|
| A      | 47.25 in (1,200 mm) | E | 26.75 in (680 mm) |
| B      | 30.00 in (762 mm)   | F | 7.00 in (178 mm)  |
| C      | 64.25 in (1,631 mm) | G | 3.125 in (79 mm)  |
| D      | 45.25 in (1,149 mm) | H | 7.75 in (197 mm)  |

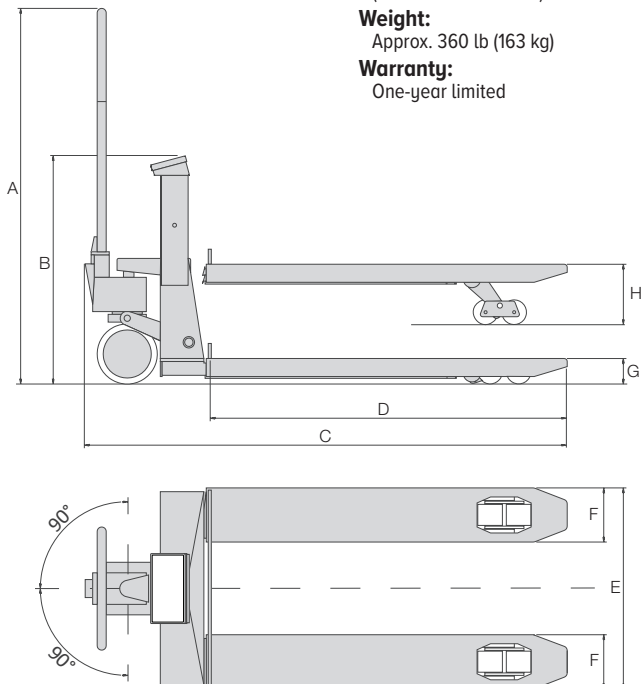

FORKLIFT /  
PALLET JACK SCALES

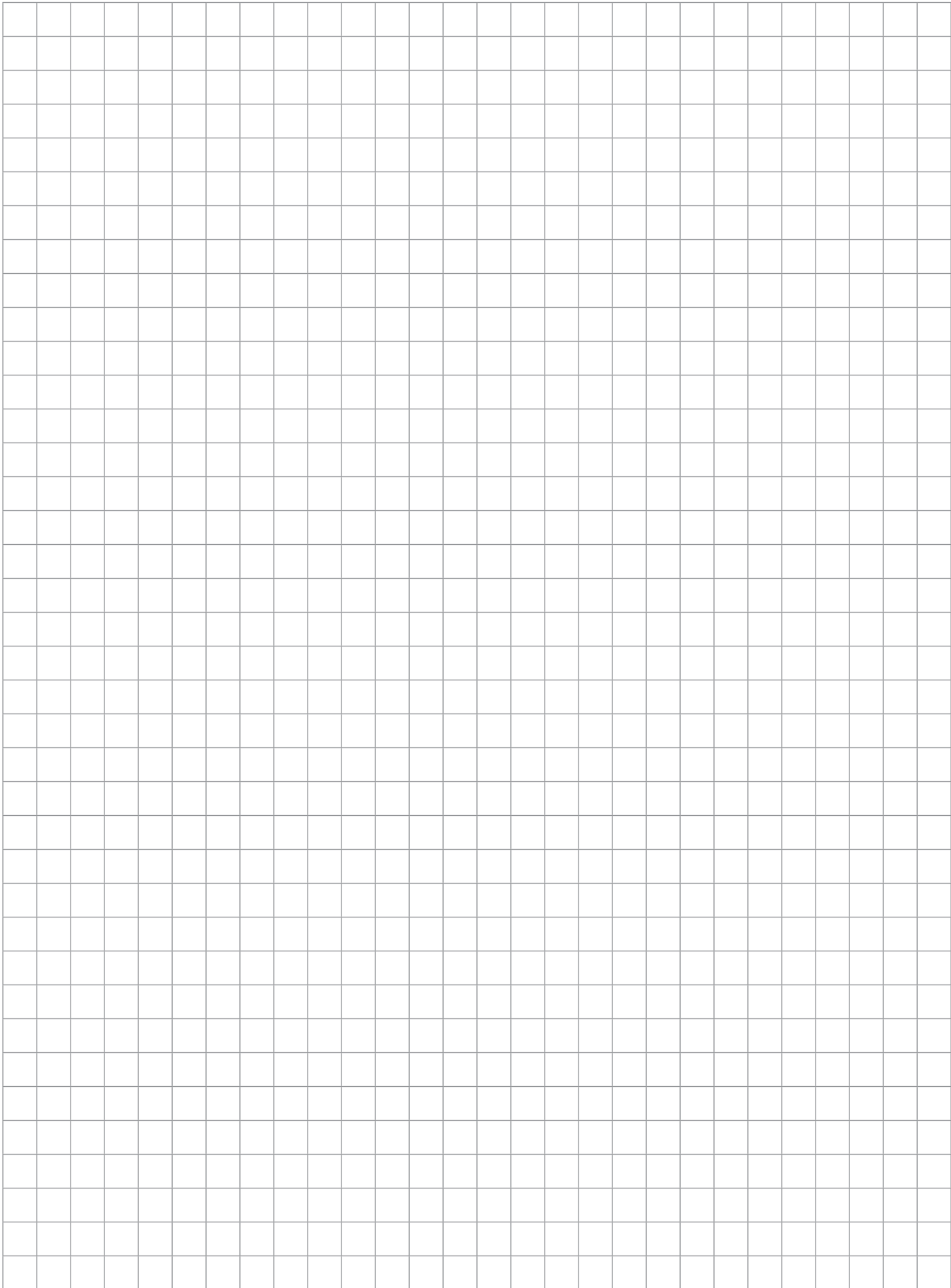

**FORKLIFT /  
PALLET JACK SCALES**

