

# MSI-4260M

*Port-A-Weigh Crane Scale*

## Technical Manual



© Rice Lake Weighing Systems. All rights reserved.

Rice Lake Weighing Systems® is a registered trademark of  
Rice Lake Weighing Systems.

All other brand or product names within this publication are trademarks or  
registered trademarks of their respective companies.

All information contained within this publication is, to the best of our knowledge, complete and  
accurate at the time of publication. Rice Lake Weighing Systems reserves the right to make  
changes to the technology, features, specifications and design of the equipment without notice.

The most current version of this publication, software, firmware and all other product  
updates can be found on our website:

[www.ricelake.com](http://www.ricelake.com)

# Revision History

This section tracks and describes manual revisions for awareness of major updates.

Revision	Date	Description
A	November 12, 2020	Initial Release
B	April 4, 2025	Updated: <ul style="list-style-type: none"> <li>• Battery information</li> <li>• Certifications</li> <li>• ScaleCore Software</li> <li>• Rugged Remote</li> </ul>

Table i. Revision Letter History



Technical training seminars are available through Rice Lake Weighing Systems. Course descriptions and dates can be viewed at [www.ricelake.com/training](http://www.ricelake.com/training) or obtained by calling 715-234-9171 and asking for the training department.

# Contents

<b>1.0</b>	<b>Introduction</b>	<b>7</b>
1.1	Features	7
1.2	FCC Compliance	7
1.3	Safety	8
1.4	Display	9
1.4.1	Keypad Functions	9
1.4.2	Annunciators and LEDs	10
<b>2.0</b>	<b>Installation</b>	<b>11</b>
2.1	Unpacking	11
2.2	D-Cell Battery Option	11
2.2.1	Battery Replacement	12
2.3	12V Sealed Lead Acid Battery Pack Option	13
2.3.1	Battery Life	13
2.3.2	Battery Charger	14
2.3.3	Battery Replacement	15
2.4	Communications Port	16
2.5	Antenna	16
2.6	Servicing	17
2.6.1	Remove Front Casting	17
2.6.2	Reinstall Front Casting	17
<b>3.0</b>	<b>Operation</b>	<b>18</b>
3.1	Power	18
3.2	Zero	18
3.3	Tare	18
3.3.1	View Tare	19
3.3.2	Clear Tare	19
3.4	Function Key	19
3.4.1	Test	19
3.4.2	Total	20
3.4.3	View Total	20
3.4.4	Net / Gross	20
3.4.5	Peak Hold	21
3.4.6	Units	21
3.4.7	High Resolution Test Mode	21
3.4.8	Print	21



Rice Lake continually offers web-based video training on a growing selection of product-related topics at no cost. Visit [www.ricelake.com/webinars](http://www.ricelake.com/webinars)

<b>4.0 Setup</b>	<b>22</b>
4.1 Setup Menu	22
4.2 Set Function Key	23
4.3 Auto-Off	23
4.4 Sleep	23
4.5 Display Brightness	24
4.6 Setpoints	24
4.7 Total	25
4.8 Filter Setup	26
4.9 Unit	26
4.10 Battery Life	26
<b>5.0 Calibration</b>	<b>27</b>
5.1 Calibration Switch Access	27
5.2 Standard Calibration	28
5.3 Initial Calibration	29
5.4 Guidelines for Capacity and Resolution	30
5.4.1 Capacity	30
5.4.2 Resolution	30
5.5 C-Cal Calibration	31
5.6 Calibration Setup Menu	32
5.7 Auto Zero Maintenance	33
5.8 Filter	33
5.9 Gravity Compensation	34
5.9.1 Compensation by Latitudes and Elevations	34
5.9.2 Compensation by Gravity Factor	35
<b>6.0 Communications</b>	<b>36</b>
6.1 Communications Menu	36
6.2 Printer Setup	37
6.2.1 Control Modes	37
6.2.2 Standard Print Strings	38
6.2.3 Printer Output Setup	39
6.2.4 Custom Print Formatters	39
6.3 RF Network Setup	40
6.3.1 MSI-4260M 802.15.4 RF Network Setup	40
6.3.2 Standby Mode	41
<b>7.0 Optional Rugged Remote</b>	<b>42</b>
7.1 Operation	42
7.1.1 Power	43
7.1.2 Zero	43
7.1.3 Programmable Function Keys	43
7.2 Conflict and Jamming Considerations	43
7.3 FCC Compliance	43



Technical training seminars are available through Rice Lake Weighing Systems. Course descriptions and dates can be viewed at [www.ricelake.com/training](http://www.ricelake.com/training) or obtained by calling 715-234-9171 and asking for the training department.

**8.0 Troubleshooting/Maintenance . . . . . 44**

8.1 Service Counters . . . . . 45

    8.1.1 Access the Service Counters . . . . . 45

8.2 Dimensions . . . . . 46

    8.2.1 MSI-4260M Port-A-Weigh Marine Scale . . . . . 46

    8.2.2 MSI-4260M Port-A-Weigh Industrial Scale . . . . . 47

**9.0 Specifications . . . . . 48**



*Rice Lake continually offers web-based video training on a growing selection of product-related topics at no cost. Visit [www.ricelake.com/webinars](http://www.ricelake.com/webinars)*

# 1.0 Introduction

This manual is intended for use by service technicians responsible for installing and servicing the MSI-4260M Port-A-Weigh Industrial Scale and the MSI-4260M Port-A-Weigh Marine Scale.

Configurations and calibration of the scale can be accomplished using ScaleCore Connect software, RF remote control, RF remote displays, or the front panel keys.



Manuals are available from Rice Lake Weighing Systems at [www.ricelake.com/manuals](http://www.ricelake.com/manuals)

Warranty information is available at [www.ricelake.com/warranties](http://www.ricelake.com/warranties)

## 1.1 Features

- Automatic power off
- Automatic sleep mode
- The buttons are sealed and rated for over 1 million operations
- Precise high resolution (2500 division standard and up to 10,000 possible) 24 bit A/D conversion coupled with advanced RISC micro controller
- five-digit, 1.75 in (11.5 mm) LCD display with programmable brightness control.
- Full digital calibration
- Can be calibrated without test weights using C-Cal technology
- Selectable for kg/lb unless prohibited by Legal-for-Trade regulations
- Automatic or manual weight totalization
- High speed Peak mode
- Three onboard LED setpoints; Five remote compatible setpoints
- ScaleCore technology
- Two service counters

## 1.2 FCC Compliance

### United States

This equipment has been tested and found to comply with the limits for a Class A digital device, pursuant to Part 15 of the FCC Rules. These limits are designed to provide reasonable protection against harmful interference when the equipment is operated in a commercial environment. This equipment generates, uses and can radiate radio frequency energy and, if not installed and used in accordance with the instruction manual, may cause harmful interference to radio communications. Operation of this equipment in a residential area is likely to cause harmful interference in which case the user will be required to correct the interference at his own expense.

### Canada

This digital apparatus does not exceed the Class A limits for radio noise emissions from digital apparatus set out in the Radio Interference Regulations of the Canadian Department of Communications.

Le présent appareil numérique n'émet pas de bruits radioélectriques dépassant les limites applicables aux appareils numériques de la Class A prescrites dans le Règlement sur le brouillage radioélectrique édicté par le ministère des Communications du Canada.

## 1.3 Safety

### Safety Definitions:



**DANGER:** Indicates an imminently hazardous situation that, if not avoided, will result in death or serious injury. Includes hazards that are exposed when guards are removed.



**WARNING:** Indicates a potentially hazardous situation that, if not avoided, could result in serious injury or death. Includes hazards that are exposed when guards are removed.



**CAUTION:** Indicates a potentially hazardous situation that, if not avoided, could result in minor or moderate injury.



**IMPORTANT:** Indicates information about procedures that, if not observed, could result in damage to equipment or corruption to and loss of data.

### General Safety



Do not operate or work on this equipment unless this manual has been read and all instructions are understood. Failure to follow the instructions or heed the warnings could result in injury or death. Contact any Rice Lake Weighing Systems dealer for replacement manuals.



#### WARNING

Failure to heed could result in serious injury or death.

Do not allow minors (children) or inexperienced persons to operate this unit.

Do not stand near the load being lifted as it is a potential falling hazard. Keep a safe distance.

Do not use for purposes other than weight taking or dynamic load monitoring.

Do not use any load bearing component that is worn beyond 5% of the original dimension.

Do not use the scale if any of the components of the load train are cracked, deformed or show signs of fatigue.

Do not exceed the rated load limit of the scale, rigging elements or the lifting structure.

Do not allow multi-point contact with the hook, shackle or lifting eye of the scale.

Do not allow high torque on the scale unless it is specifically designed for high torque.

Do not make alterations or modifications to the scale or associated load bearing devices.

Do not use improperly rated or sized shackles. Use only Rice Lake Weighing Systems recommended shackles.

Do not remove or obscure warning labels.

For guidelines on the safe rigging and loading of overhead scales, read the Rice Lake Weighing Systems Crane Scale Safety and Periodic Maintenance Manual (available at [www.ricelake.com](http://www.ricelake.com)).

Keep hands, feet and loose clothing away from moving parts.

There are no user serviceable parts within the MSI-4260M. Any repairs are to be performed by qualified service personnel only.

The MSI-4260M Port-A-Weigh scale has a safe mechanical overload of 200% and an ultimate overload of 500%. Overloads greater than 50% could result in structural failure and dropped loads. Dropped loads could cause serious personal injury or death.



## 1.4 Display

The keys and display of the MSI-4260M front panel are shown and described below:



Figure 1-1. Front Panel

### 1.4.1 Keypad Functions

The functions of the push buttons vary based on the current MSI-4260M mode.











Key		Weigh Mode	Setup Menu Navigation	Numeric Entry
<b>POWER</b> 	Power Key	Turns the MSI-4260M On and Off	Exits setup without saving changes; <b>ANCEL</b> displays momentarily and unit enters <b>Weigh</b> mode	Enters decimal point to the left of the blinking digit
<b>ZERO</b> 	Zero Key	Zeros out residual weight on the scale	Saves and drops back one menu level; At the root menu level the Zero key stores the changes and returns to Weigh mode <b>StorE</b> displays briefly	Steps back one digit to change or correct the digit to the left
<b>TARE</b> 	Tare Key	Removes the weight of containers, trucks or carriers and places the scale in the Net Weigh mode	Functions as the Enter/Select key	Confirms blinking digit and move to the digit to the right
<b>USER</b> 	User Key	Programmable to user selectable functions ( <a href="#">Section 4.2 on page 23</a> ); This key is defaulted to the Test function	Functions as the Scroll key	Cycles blinking digit through numbers 0-9

Table 1-1. Key Functions

Example of numeric entry: Enter 2500 kg on a 5000 kg capacity scale.

- Press **USER**  two times for the leftmost blinking digit, press **TARE**  to save that digit selection.
- Press **USER**  five times for the next blinking digit, press **TARE**  to save that digit selection.
- Press **TARE**  to save that digit selection.
- Press **TARE**  to save the next digit selection. *2500* displays.

### 1.4.2 Annunciators and LEDs



Figure 1-2. Front Panel

Annunciator	Name	Description
	Battery Level	Displays representation of the battery level: 100%, 75%, 50%, 25% and 0%
	Center of Zero	Indicates that the scale is zeroed and the weight is within 1/4d of zero
	Negative Sign	Allows scale to display five digits and a negative sign
	Stable	Indicates that the weight has settled within the motion window (usually $\pm 1d$ ); When this symbol is off, the scale will not zero, tare or totalize
	Radio Frequency	Indicates an active radio communication link with a scale or indicator
	Setpoint LED	Eight user programmable setpoints for early overload warnings; Red LED = Setpoint 1, Yellow LED = Setpoint 2, Green LED = Setpoint 3
	Standby LED	Indicates standby mode is active when the scale is turned off.
<b>x1000</b>	x1000	Indicates weight display or accumulation beyond the 5 digit display limit by a multiplier of 1000; If 1K is illuminated, read the total as the displayed value multiplied by 1000
<b>Ttl</b>	Total	Blue LED indicates the total weight displays for five seconds or less
<b>Net</b>	Net	Indicates the scale is in Net mode; Tare weight has been subtracted from the gross weight
<b>lb</b>	LB	Red LED indicates weight display is in pounds
<b>kg</b>	KG	Red LED indicates weight display is in kilograms
<b>88888</b>	Display	Five-digit, 1.75" (44.5 mm) LCD display with programmable brightness control

Table 1-2. Annunciators and LEDs



**WARNING:** Wear appropriate hearing protection when any audible alarm is active. Not wearing appropriate hearing protection may result in hearing loss.

## 2.0 Installation

This section provides an overview of MSI-4260M Port-A-Weigh crane scale installation instructions.

The MSI-4260M cast aluminum enclosure is rated at NEMA Type 4 IP 66. It hangs from a crane using properly sized shackles.



**WARNING:** Refer to the *Crane Scale Safety and Periodic Maintenance Manual (PN 153105)* for safe loading and rigging guidelines when installing the MSI-4260M.

*Regular maintenance inspections of the lifting system should be performed to ensure safety. Pay attention for signs of stress on any element in the load train.*

Use the appropriate interface hardware for the capacity of the scale.

- If the interface hardware does not fit properly, Rice Lake Weighing Systems can supply the MSI-4260M with oversize lifting eyes or shackle interfaces
- If the crane hook is too large to fit in the lifting eye with single point interface then install the scale using adaptive rigging
- If multiple attachments are needed, use a shackle or ring to attach the multiple lines to keep a single point attachment to the scale



**IMPORTANT:** Using an oversize shackle or hook to interface with the MSI-4260M can cause off center loading and stress points that reduce the life of the lifting eye or hook.

*Single point attachments are necessary to ensure the safety and accuracy of the scale system.*

### 2.1 Unpacking

Immediately after unpacking the MSI-4260M from the shipping container, visually inspect the product to ensure all components are included and undamaged. If parts were damaged in shipment, notify Rice Lake Weighing Systems and the shipper immediately. If the MSI-4260M must be returned, it must be properly packed with sufficient packing materials.

Whenever possible, use the original carton when shipping the unit back. It is good practice to retain the shipping container for future shipping or transporting of the unit.

### 2.2 D-Cell Battery Option



**NOTE:** For optimal performance, replace all six batteries with new batteries from the same type and manufacturer.

The MSI-4260M Marine Crane Scale is powered by six (6) D cell 1.5 V alkaline batteries. Optionally, the MSI-4260M Industrial Crane Scale can be powered by D cell batteries or a 12V Sealed Lead Acid Battery Pack shown in [Section 2.3 on page 13](#).

The operating battery life of six (6) D cell batteries is up to 1000 hours depending on the following factors:

- The brightness of the LCD display backlight
- The amount of RF activity
- The age and condition of the batteries

In order to conserve battery life, the MSI-4260M includes the following features.

- **Automatic Power Off Mode** – Senses no activity after the set amount of minutes and turns the scale off
- **Automatic Sleep Mode** – Dims the display after a set amount of minutes of no scale activity

Do not store the MSI-4260M with the batteries inside. Remove the batteries if the unit will not be used for more than two weeks.



**NOTE:** Replace batteries once the battery annunciator is flashing.

## 2.2.1 Battery Replacement

1. Turn the MSI-4260M off.
2. Unscrew battery caps.
3. Slide battery tubes from the MSI-4260M.
4. Remove batteries from tubes.
5. Install new batteries with plus side up.
6. Reinstall battery tubes.



Figure 2-1. Battery Replacement



**IMPORTANT:** Periodically, inspect o-rings and threads to maintain a tight seat of the battery tubes.



**CAUTION:** Batteries and battery tubes can be a dangerous falling hazard. When opening battery tubes, be sure to hold to prevent from falling.

## 2.3 12V Sealed Lead Acid Battery Pack Option

The MSI-4260M Industrial Crane Scale can be powered by a rechargeable 12V Sealed Lead Acid (SLA) battery. This battery will operate for up to 100 hours (depending on the backlight brightness setting) before requiring recharging.

Charging time for a completely discharged lead acid battery pack is up to eight hours. A spare battery pack is recommended to keep the MSI-4260M Industrial Crane Scale in continuous operation.



**NOTE:** *The MSI-4260M Marine Crane Scale does not include a lead acid battery pack option.*



**IMPORTANT:** *To obtain maximum service life from batteries, store between - 4°F and 122°F (-20 °C and +50°C). Recharge stored batteries every three months. The status indicator on the battery charger flashes when the battery is fully charged.*

### 2.3.1 Battery Life

The battery life of the MSI-4260M with SLA battery pack depends on several factors:

- The brightness of the LED display and the number of segments lit
- The amount of RF activity
- The age of the battery
- The condition of the SLA battery

To conserve battery life, the MSI-4260M includes the following features.

- **Automatic Power Off Mode** — Senses no activity after the set amount of minutes and turns the scale off
- **Automatic Sleep Mode** — Dims the display after scale has been idle for a set amount of minutes

The MSI-4260M automatically turns off when the SLA battery drops to approximately 10.5V. Recharge the battery when this happens; SLA batteries benefit from frequent recharging and can be recharged when they still have available life.

Due to the maintenance discharge imposed on the battery by the MSI-4260M electronics, do not store the MSI-4260M with the battery inside. Remove the battery if it will not be used for more than two weeks.



**IMPORTANT:** *Leaving a discharged battery in the scale, which has a maintenance battery drain, can result in a deeply discharged battery, which will shorten its service life.*



**NOTE:** *An additional fully charged spare battery is recommended if the scale is continuously used. Replace the drained battery as close as possible to the low battery warning.*

*\*SLA batteries that are not deeply discharged should withstand 500 to 1500 charging cycles.*

*\*The low battery warning annunciator indicates about two to four hours of additional use before MSI-4260M powers off.*

*\*Remove the SLA battery to prevent deep discharge while the unit is in storage if the MSI-4260M will not be used again soon.*

*\*Recycle the battery at an authorized recycling center when the average life drops to 20 hours or less*

### 2.3.2 Battery Charger

The MSI-4260M SLA battery pack is shipped with a charger to charge and maintain the battery. The exact charging time will depend on the degree of discharge of the battery. It should take about four hours to fully charge a battery if it is removed when the low battery warning first appears.



**DANGER:** The charger is for indoor use only and should not be used in wet locations.



**NOTE:** The initial charge might take significantly longer when the battery is new. It is recommended to charge a new battery for 24 hours. It might take several charge/discharge cycles before full capacity is reached. Deep-discharged batteries will also take significantly longer to charge.

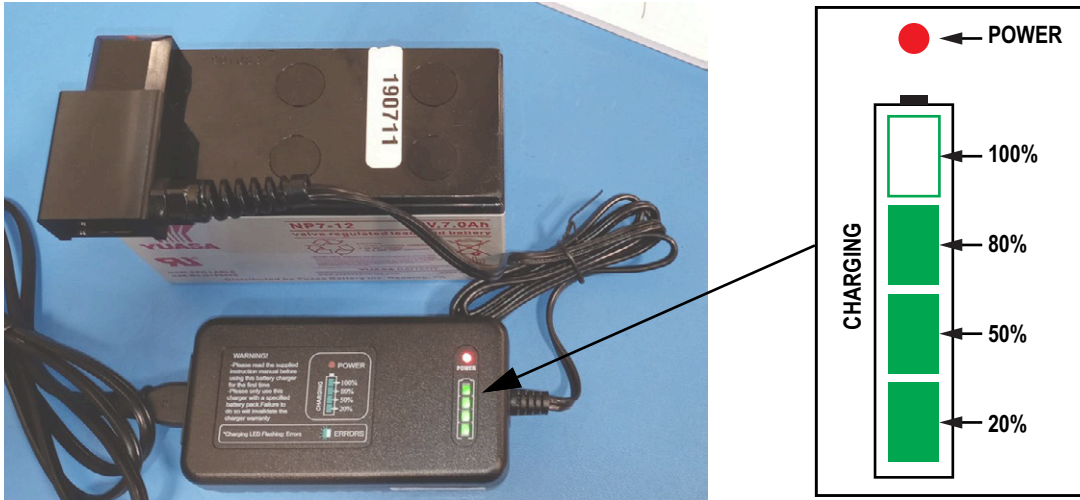

Figure 2-2. Battery Charger Connected to Battery

The battery charger illuminates annunciators as the battery charges.

1. Remove the battery from the MSI-4260M (Figure 2-1 on page 12).
2. Connect the charger assembly to the AC power supply (86-260 VAC). The power annunciator displays red.



**NOTE:** If the power status light fails to illuminate, check the AC power connection to ensure the V in the jack is fully seated. AC power cords suitable for any world location are available from Rice Lake Weighing Systems.

3. Plug the polarized connector into the jacks on the battery. Charging annunciators illuminate to represent charge percentage.
4. Charge until all of the status annunciators are fully illuminated.

When the charge cycle is complete, the battery can be left on the charger until needed. The charger keeps a maintenance float charge on the battery to ensure the best possible operation times.



**IMPORTANT:** For maximum battery service life, the manufacturer suggests recharging after each 20 hours of use. Continuous deep discharging reduces the maximum battery life cycle, estimated at 2000 cycles.

### 2.3.3 Battery Replacement

To replace the SLA battery pack:

1. Turn the MSI-4260M off.
2. Secure the battery cover.
3. Release the latches holding the battery cover.
4. Slowly lower the cover while holding the battery in place.
5. Remove the battery by pulling it straight back.
6. Install a fully charged battery by plugging it into the exposed battery jacks.
7. Close the battery cover.
8. Reset the latches. Ensure the latches are completely latched and the cover is firmly in place.



Figure 2-3. Remove Battery



**IMPORTANT:** Periodically inspect the battery latches for fit. Adjust the screw latch by rotating the catch on its threads to maintain a tight seal on the battery O-ring.



**CAUTION:** The 12V Sealed Lead Acid battery can be a dangerous falling hazard. When opening the battery hatch, be sure to hold the battery to prevent it from falling. These batteries contain lead and should be recycled when they have reached the end of their life.



## 2.4 Communications Port

The MSI-4260M has a single communications port allowing access to the embedded ScaleCore through the terminal access mode or ScaleCore Connect. The terminal access mode is used for updating scale firmware while ScaleCore Connect can be used for calibration and configuration, backup and adjusting scale settings. This communications port is not intended for output use.

The MSI-4260M comes standard with one communications port cable wired for RS-232 following the AT standard for 9-pin serial cables (DCE). An un-terminated cable is also available for wiring the serial cable for RS-232.

Table 2-1 shows the wiring color code.

Signal	Wire Color
TxD (transmitted data)	Brown
RxD (received data)	Black
CTS (clear to send)	Gray
RTS (request to send)	White
GND (ground)	Blue
PG (protective ground)	Drain Wire

Table 2-1. RS-232 Wiring Code

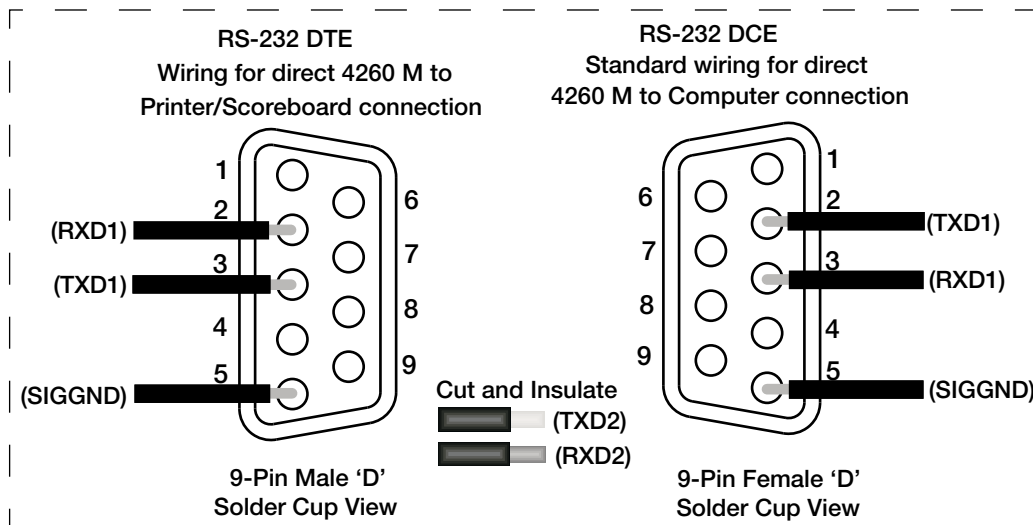

Figure 2-4. Comm Port Cable Assignments Examples

## 2.5 Antenna

The 2.4 GHz internal antenna is the standard type of antenna used for overhead scale applications and is only included in RF models. The internal antenna is resilient to the possible physical damage of outdoor application, but is directional, which requires more care in antenna placement for long range applications. Internal antennas are available by special order only. Please contact Rice Lake Weighing Systems for details.

Ensure a relatively clear transmission path exists between the devices to be connected. Make sure the antenna is not blocked by any metal. Transmission is good through most kinds of glass, so mounting next to a window works fine. Radio signals travel primarily by line of sight (LOS), obstructions between stations may degrade the system performance.



**NOTE:** The antenna is optional to a non-RF MSI-4260M unit. The antenna is standard to all RF MSI-4260M devices.



## 2.6 Servicing

The Rice Lake dealer network provides both on-site and depot servicing of the MSI-4260M. Please contact a local dealer or Rice Lake Weighing Systems to obtain a return material authorization (RMA). Due to the weight and size of many products, it is not always necessary to return the entire unit. There are no user serviceable parts inside the MSI-4260M. Depot repair is performed with module and harness swaps. If the electronics are at fault, often the front casting is the only part needed to be returned.

### 2.6.1 Remove Front Casting

See the following procedure to remove the front casting:

1. Remove the cap screws (x4).
2. Unplug connectors.
3. Package the front casting well for safe shipping.

### 2.6.2 Reinstall Front Casting

See the following procedure to reinstall the front casting:

1. Clean the front casting and bulkhead o-ring grooves with isopropyl alcohol.
2. Reconnect the load cell cables and power cables then tighten the cables.
3. While securing the o-ring, ensure the o-ring is flush with the o-ring grooves.



**WARNING:** Replace damaged o-rings when necessary. Damaged o-rings may break the unit seal, causing water penetration.

4. Insert the bolts (x4) into the front casting then torque the bolts to 20-25 ft-lbs.



**NOTE:** Apply anti-seize compound as necessary.

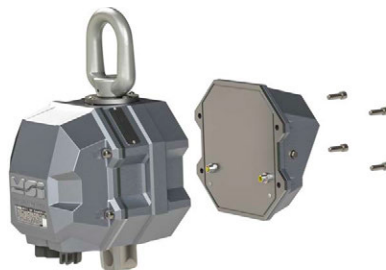

Figure 2-5. Remove Front Casting

## 3.0 Operation

This section provides an overview of MSI-4260M Port-A-Weigh Crane Scale operation instructions.

### 3.1 Power

Press **POWER**  to turn on the power. The following sequence displays:

1. All LED segments light at full brightness as a display test.
2. *SOFt* displays, followed by the software version number.
3. *StAnd* followed by the weighing standard.
4. *bAtt* displays, followed by the battery voltage.
5. *d. tESt* displays, followed by the display counting from 00000 to 99999.
6. *C-CAL* displays, followed by the C-CAL value.
7. MSI-4260M enters Weigh mode.

While in Weigh mode, press **POWER**  to turn off the power.



**IMPORTANT:** *The scale has a maintenance battery drain. Always remove the battery if the scale will be off for an extended period of time. Leaving a discharged battery in the scale can result in a deep discharged battery which will shorten its service life.*

### 3.2 Zero

**ZERO**  sets the zero reading of the scale.

Press **ZERO**  to remove small deviations in zero when the scale is unloaded. For zeroing (taring) package or pallet weights, see [Section 3.3](#).



**NOTE:** *The backup memory in the unit stores the zero reading and retains it even if the power fails.*

*Zeroing while in NET mode will zero the GROSS weight causing the display to show a negative tare value.*

*The scale must be stable within the stable window.*

*The unit will only zero if  is on and there has been no activity for two seconds. If a motion ceases within the motion window in that time, the scale will zero.*

*The scale will accept a zero setting over the full range of the scale (NTEP and other legal for trade scales may have limited zero range).*



*Zero settings above 4% of full scale will subtract from the overall capacity of the unit.*

*\*Example: If 100 lb on a 1,000 lb scale is zeroed, the overall capacity of the scale will reduce to 900 lb, plus the allowed over-range amount.*

### 3.3 Tare

Tare is used to zero out a packing container or pallet, and display a **NET** weight. The **TARE** function is defined as a **Tare-In** or **Tare-Out** operation.

To tare the scale:



1. Hang/place the empty container from the scale.
2. Press **TARE**  to enter a tare value. The MSI-4260M stores the current weight as a tare value and subtracts the value of the container from the **GROSS** weight.  displays and the weight mode changes to **NET**.
3. Add the product to the packing container. The **NET** weight is displayed.



**NOTE:** *To set a new tare, the existing tare must first be cleared. The MSI-4260M will not set a new tare over an old tare.*

### 3.3.1 View Tare

To view the **GROSS** weight without clearing the tare value:

1. Program **USER**  to the **NET/GROSS** function ([Section 4.3 on page 34](#)).
2. Press **USER**  to toggle between net and **GROSS** values. This will only work if a tare value has been established.



**NOTE:** The backup memory in the MSI-4260M stores the Tare reading and can restore it even if power fails.

Only positive **GROSS** weight readings can be tared. The **STABLE** annunciator must be on, indicating weight reading is stable. Setting or changing the tare has no effect on the **GROSS** zero setting. Taring will reduce the apparent over range of the scale. The RF Remote Control has **NET/GROSS** permanently available.

*Example: Taring a 100 lb container on a 1,000 lb scale, the scale will overload at a NET weight of 900 lb (1,000-100) plus any additional allowed overload (usually 4% or 9d).*

### 3.3.2 Clear Tare

To clear a saved tare value, press **TARE** . The **GROSS** weight displays.



**NOTE:** Only positive gross weight readings can be tared.

The  must be off indicating weight reading is stable.

Setting or changing the tare has no effect on the gross zero setting.

Taring will reduce the apparent over-range of the scale.

The scale stores the tare value in non-volatile memory and is restored when power is cycled.

*Example: Taring a 100 lb container on a 1000 lb scale, the scale will overload at a net weight of 900 lb (1000-100) plus any additional allowed overload (usually ~4% or 9d).*

## 3.4 Function Key

The **USER**  key can be programmed in the setup menu ([Section 4.2 on page 23](#)) to one of the following functions. Some functions require additional programming in the setup menu to work correctly.

### 3.4.1 Test

When the **USER**  key is programmed to **TEST** ([Section 4.2 on page 23](#)), pressing the key prompts the scale to scroll through the following sequence and returns to Weigh mode:

1. All LED lights display momentarily at once.
2. **Soft** displays, followed by the software version number.
3. **Stand** followed by the weighing standard
4. **Batt** displays, followed by the battery voltage.
5. **d. TEST** displays, followed by the display counting from 00000 to 99999.
6. **C-CAL** displays, followed by the C-CAL value.



**NOTE:** Other internal tests are performed and if any test fails, an error code displays. See [Section 8.0 on page 44](#) for information on the troubleshooting guide.





### Automatic Scroll Test

- Press **USER**  to start the test



The unit automatically scrolls through the test sequence and returns to Weigh mode

## Single Step Test Mode

To stop the automatic scroll of the test procedure, begin the automatic scroll test and press **USER**  again within two seconds to enable a single step test mode.

1. Press **USER**  to scroll through the available test functions.
2. Press **TARE**  to start or display the individual tests.
3. Press **ZERO**  to exit individual tests.
4. Press **ZERO**  to exit from the test function.

### 3.4.2 Total

When the **USER**  key is programmed to **TOTAL** (Section 4.2 on page 23), pressing the key prompts the scale to perform the total function that has been set in the setup menu. That can be, **OFF**, **ENTER**, **A. LOAD**, **A. LAST**, or **A. H. GH**. For more information on these parameters and setup see Section 4.7 on page 25. If nothing has been set, nothing will happen when **USER**  is pressed.



- Press **USER**  to start the complete the total function



**NOTE:** The Total mode must be programmed from the Setup menus before the USER key will function.

### 3.4.3 View Total

When the **USER**  key is programmed to **VIEW TOTAL** (Section 4.2 on page 23), pressing the key prompts the scale to display total weight followed by the number of samples that have been saved.

1. Press **USER**  to display the total weight.
2. With the Total weight displayed, press **ZERO**  to clear.

### 3.4.4 Net / Gross

When the **USER**  key is programmed to **NET/GROSS** (Section 4.2 on page 23), pressing the key prompts the scale to switch the display between **NET** and **GROSS** modes. This will only work if a tare value has been established.

- Press **USER**  to toggle between NET and GROSS modes

**NET** weight is defined as **GROSS** weight minus a tare weight.

The operator can switch back to **GROSS** from **NET** without clearing the tare value. Only clearing or setting a new tare will change the tare value held before switching into **GROSS** mode.



**NOTE:** OIML Legal for Trade units only: The NET/GROSS key is a temporary action only. The GROSS weight displays for two seconds and then the display returns to the NET mode. The only way to return to permanent GROSS readings is to clear the tare (Section 3.3.2 on page 19).

### 3.4.5 Peak Hold

When the **USER** key is programmed to *P-HLD* (Section 4.2 on page 23), pressing the key clears and re-enables the scale to only update the display when a higher weight reading is established. The peak hold function uses a high-speed mode of the A/D converter allowing it to capture transient weights at a far higher rate than typical scales.

Peak hold is cleared and re-enabled with the **USER** key, that has been set to *P-HLD*.

Peak hold is not available on NTEP or OIML Legal for Trade certified scales.

### 3.4.6 Units

When the **USER** key is programmed to *UNIT* (Section 4.2 on page 23), pressing the key changes the displayed units.

- Press **USER** to toggle display between available units



**NOTE:** Unit switching is not available on OIML certified Legal-for-Trade scales.

### 3.4.7 High Resolution Test Mode

When the **USER** key is programmed to *H-RES* (Section 4.2 on page 23), pressing the key prompts the scale to toggle between normal Weigh mode and High Resolution Test mode. High Resolution Test mode displays weight at x10 resolution. While in High Resolution Test mode, all of the annunciators flash to indicate that the weight display is not set to the approved legal-for-trade resolution.

- Press **USER** to toggle between normal and x10 resolution display

In some cases, the displayed weight in high resolution test mode will require six digits to fully display. In these cases, only the five least significant digits will be displayed. The full weight can be displayed in normal resolution by pressing the function button.

Ex: 1000.02 kg displays as 000.02 kg.



**NOTE:** High resolution test mode is for scale service and diagnostic use only.

*Increasing the scale display resolution beyond the calibrated value does not increase scale accuracy.*

*High resolution test mode is not available in HB-44 and R-76 standards.*

### 3.4.8 Print

When the **USER** key is programmed to *PRINT* (Section 4.2 on page 23), pressing the key prompts the scale to print.

- Press **USER** to print





**NOTE:** The print option must be installed and the print function must be set up in order for the print button to work. See Section 6.1 on page 36 for print setup information.

## 4.0 Setup

The Setup menu enables configuration of the MSI-4260M. This section details settings and parameters that are configured in the Setup menu. For navigation and numeric entry information, see [Section 1.4.1 on page 9](#).

### 4.1 Setup Menu

To enter into the MSI-4260M setup menu, press **POWER**  and **USER**  simultaneously.

Parameters	Choices	Description
FUNCTION 1 FUNCTION 2	OFF	Function User Key 1 – User definable key that can be programmed to one of several functions
		Function User Key 2 – User definable key that can be programmed to one of several functions; Only available on the RF remote being used with the MSI-4260M
	TEST	Test Display – <a href="#">Section 3.4.1 on page 19</a>
	TOTAL	Total – <a href="#">Section 3.4.2 on page 20</a>
	VIEW TOTAL	View Total – Function always available on the RF Remote ( <a href="#">Section 3.4.3 on page 20</a> )
	NET/GROSS	Net/Gross – Function always available on the RF Remote ( <a href="#">Section 3.4.4 on page 20</a> )
	PEAK HOLD	Peak Hold – <a href="#">Section 3.4.5 on page 21</a> ; Function not available or non-functional in OIML R76 or NTEP HB44 modes
	UNITS	Units – <a href="#">Section 3.4.6 on page 21</a> ; Function not available or non-functional in OIML R76 & 1Unit modes
	HIGH RES	High Resolution – x10 display resolution; For testing and maintenance use only; Not a legal Weigh mode; Does not increase scale resolution or accuracy <a href="#">Section 3.4.7 on page 21</a>
	PRINT	Print – <a href="#">Section 3.4.8 on page 21</a>
AUTO OFF	OFF 15 30 45 60	Auto Off Time – Prolongs battery life of scale by turning power off after the set time (in minutes) that the scale is not in use ( <a href="#">Section 4.3 on page 23</a> )
SLEEP	OFF 5 15 30	Sleep – Time (in minutes) before unit will enter the sleep mode ( <a href="#">Section 4.4 on page 23</a> )
DISP L	LD-1 LD-2 HI-1 HI-2 AUTO	LED Display Intensity – Used to set the display brightness ( <a href="#">Section 4.5 on page 24</a> )
SETPOINT 1-8	OFF GREAT LESS	Setpoint 1 to 8 – Used for warnings or process control ( <a href="#">Section 4.6 on page 24</a> )
TOTAL	OFF TOTAL ON A. LOAD A. LAST A. HIGH	Total Mode – accumulation of multiple weighments ( <a href="#">Section 4.7 on page 25</a> )
WEIGHT FILTER	OFF LD HI-1	Weight Filter – allows the scale to adjust to situations where there may be movement ( <a href="#">Section 4.8 on page 26</a> )
UNITS	Lb KG	Weight Units – toggle units between pounds and kilograms; Function not available or non-functional in OIML R76 & 1Unit modes ( <a href="#">Section 4.9 on page 26</a> )
BATTERY LIFE	STANDARD LONG	Battery Life – sets the options for standard or extended battery life ( <a href="#">Section 4.10 on page 26</a> )

Table 4-1. Function Key Settings

## 4.2 Set Function Key

The MSI-4260M has one user definable key **USER** on the front panel, that can be programmed to one of several functions. The additional function key is available on the RF remote control being used.

 **NOTE:** If a function key does not work, it is probably because the MSI-4260M is not set up to support the key. For example, if the Function Key is set for TOTAL, the TOTAL mode must also be set up in the Setup menu.

To set the function key use the following steps:

1. Press and hold **USER** and **POWER**. **FUNC** displays.
2. Press **TARE**. The current user key function displays.
3. Press **USER** to scroll through the available functions.
4. Press **TARE** when the desired function displays. **OFF** displays.
5. Press **ZERO**. **SLEEP** displays, the unit exits setup and stores the settings.

 **NOTE:** Press **POWER** at any time to cancel the procedure.

## 4.3 Auto-Off

The **Auto-Off** feature prolongs the battery life by automatically powering off the unit if no buttons are pressed and there is no change in the load exceeding 10 d for the time period, in minutes, set by the user. When a button is pressed or the detected load is in motion exceeding 10 d, the time limit is reset.

When disabled, the unit will only turn off by pressing **POWER**, or if the battery dies. To set the **Auto-Off** function:

1. Press and hold **USER** and **POWER**. **FUNC** displays.
2. Press **USER** to scroll to **OFF**.
3. Press **.** The current auto off time displays.
4. Press **USER** to scroll through the available times.
5. Press **TARE** when the desired time displays. **SLEEP** displays.
6. Press **ZERO** to exit setup and store the settings.

 **NOTE:** Press **POWER** at any time to cancel the procedure.

## 4.4 Sleep

The sleep parameter reduces power consumption by automatically turning off the display during periods of inactivity. While in the sleep mode, the green acknowledge annunciator will blink at a one second rate to indicate the unit is in sleep mode. To wake up the unit, either a button must be pushed (front panel or RF remote) or the weight must change by 5 d or more.

 **NOTE:** Sleep must be set to less time than the Auto-Off timer.

1. Press and hold **USER** and **POWER**. **FUNC 1** displays.
2. Press the **USER** to scroll to the **SLEEP** function.
3. Press **TARE**. The current **SLEEP** time displays.
4. Press the **USER** to scroll through the available times.
5. Press **TARE** when the desired time displays. **d, SPL** displays.
6. Press **ZERO** to exit setup and store the settings.

 **NOTE:** Press **POWER** at any time to cancel the procedure.



## 4.5 Display Brightness

The **Display** setup menu is used to set the display brightness. There are four fixed brightness settings and one automatic light sensing brightness setting.

Auto setting automatically detects the ambient light and adjusts the brightness of the display accordingly.

There are four fixed brightness settings, **LO-1**, **LO-2**, **HI-1** and **HI-2**. Lower brightness settings increase battery life.

1. Press and hold **USER** and **POWER**. **FUNC 1** displays.
2. Press the **USER** to scroll to the **DISPL**.
3. Press **TARE**. The current setting displays.
4. Press the **USER** to scroll through the available settings.

**NOTE:** The display brightness changes when each setting displays.

5. Press **TARE** when the desired setting displays. **COLOR** displays.
6. Press **ZERO** to exit setup and store the settings.

**NOTE:** Press **POWER** at any time to cancel the procedure.

## 4.6 Setpoints

The MSI-4260M supports eight user programmable setpoints. Common uses of setpoints are for warnings or process control. Setpoints 1-3 are visible on the device and have LED outputs that can be setup in the **RF** menu (Section 6.0 on page 36). Setpoints 4-8 can only be used by connecting a compatible RF remote control or RF remote display.

Setpoint 1 is Blue  
Setpoint 2 is Green  
Setpoint 3 is Red



Figure 4-1. Setpoint LEDs

The MSI-4260M has an audible output option that is triggered by Setpoint 1. Contact Rice Lake Weighing Systems for other setpoint output options. To set the setpoint:









Setpoint	Description
<b>Setpoint Mode</b>	
GREAT	Great – Indicates the setpoint triggers when the weight exceeds a set value
LESS	Less – Indicates the setpoint triggers when the weight is less than a set value
<b>Setpoint Weight Type</b>	
NETGR	Net/Gross – Responds to net or gross weight
GROSS	Gross – Responds to gross weight regardless of the display
TOTAL	Total – Responds to the totaled weight
T-CNT	Total Count – Responds to the total count (number of samples)
LFcnt	LF Count – Responds to the number of times the weight has exceeded 25% of capacity

Table 4-2. Available Setpoint Settings



To set the setpoint:



1. Press and hold **USER** and **POWER**. **FUNC 1** displays.
2. Press **USER** to scroll to the desired setpoint (**SETPT 1 - 8**).



3. Press **TARE** . The current **SET** mode displays.
4. Press **USER**  to scroll to the setpoint mode desired.
5. Press **TARE** . The current **SET** weight type displays.
6. Press **USER**  to scroll to the desired weight type.
7. Press **TARE** . The current setpoint weight value displays.
8. Press **USER** . The first digit will blink.
9. Press **USER**  to scroll to the desired number.
10. Press **TARE** . The second digit blinks.
11. Repeat [Step 8](#)– [Step 10](#) until the desired value displays.



**NOTE:** To enter a decimal point, press **POWER**  while the digit is blinking. To correct a digit, press **ZERO**  to step back.

12. Press **TARE** . The value will stop blinking and the next setup menu item displays.
13. Repeat [Step 2](#) – [Step 12](#) to set all the setpoints to be used.
14. Press **ZERO**  to exit setup and store the settings.



**NOTE:** Press **POWER**  at any time to cancel the procedure.

## 4.7 Total

Total function is used to accumulate multiple weighments so that gross and net readings can be added into the same total number. There are four modes of totalizing: one manual mode and three auto modes.

The manual total mode and three auto total modes all require that the weight on the scale return below 0.5% (relative to full scale) of **GROSS ZERO** or **NET ZERO** before the next weighment can be added. Applied weight must be  $\geq 1\%$  of full scale above **GROSS ZERO** or **NET ZERO** before it can be totaled.

### Manual Total Mode

The manual mode requires the **TOTAL** key be pressed with the weight on the scale. The weight will be added to the previously accumulated value. This assures that a weight on the scale is only added to the total once.

The **USER** key under the **MANUAL TOTAL** mode functions in this manner:

- If weight is greater than 1% of capacity and has not been totaled – Pushing the **USER** key will add the current weight to the TOTAL weight. The displayed weight blinks to indicate the weight was accepted. The TOTAL annunciator lights and the Total weight displays for five seconds and then the number of samples displays for two seconds.
- If current Weight has been totaled – Pushing the **USER** key displays the Total weight for five seconds (View Total) without changing the Total value. The TOTAL annunciator will light during the TOTAL weight display. After five seconds of Total Weight display, the number of samples displays for two seconds.
- If weight is less than 1% of capacity – The **USER** key functions as View Total only and functions as View Total until the 1% threshold is exceeded to allow the next addition to the total value.



### Auto Total Modes

The **USER** key under the **AUTO TOTAL** mode functions as Auto Total On / Auto Total Off.

The Auto mode has three variations which are programmed in the Setup menu:

- **R. Load – AutoLoad** ensures any settled load above the Rise above threshold will be automatically totaled. The scale must fall below the Drop below threshold before the next total is allowed.
- **R. Last – AutoLast** mode takes the last settled weight to auto total with. The total occurs only once the scale goes below the threshold. This allows the load to be adjusted without a total occurring. Once the load is removed, the scale uses the last settled reading for total.
- **R. High – AutoHigh** uses the highest settled reading. This is useful for loads that can't be removed all at once.



**NOTE:** Total mode will not function while the scale is in motion, make sure   is on. If the system fails to achieve stable readings, increase the filter setting or increase the size of the scale division (d) in the Init Cal procedure.

**NOTE:** If 1K is illuminated, read the total as the displayed value multiplied by 1000.

## Set Total Mode

1. If the unit is turned off, press and hold **USER** then press **POWER**.  
If the unit is on, press **USER** and **POWER** simultaneously. *FUNC 1* displays.
2. Using the **USER**, scroll to *TOTAL*.
3. Press **TARE**. The currently saved total mode displays.
4. Press **USER** to scroll through the choices.
5. With choice displayed, press **TARE** to select. *FILTER* displays.
6. Press **ZERO** to save and exit to weighing mode or press **USER** to continue to another setup menu item.

## 4.8 Filter Setup

Changing the filter settings allows the scale to adjust to situations where there is a lot a movement in the structure. If the reading is not stable, it can often be improved by increasing the filter setting. Settling time will be longer as the filter setting is increased. However, the MSI-4260M employs algorithms that speed up large weight changes while still controlling vibration even with high filter settings.

Use the following steps to set up filtering.

1. If the unit is turned off, press and hold **USER** then press **POWER**.  
If the unit is on, press **USER** and **POWER** simultaneously. *FUNC 1* displays.
2. Using the **USER**, scroll to *FILTER*.
3. Press **TARE**. The currently saved total mode displays.
4. Press **USER** to scroll through the choices.
5. With choice displayed, press **TARE** to select. *UNIT* displays.
6. Press **ZERO** to save and exit to weighing mode or press **USER** to continue to another setup menu item.

## 4.9 Unit

1. Press and hold **USER** and **POWER**. *FUNC 1* displays.  
If the unit is on, press **USER** and **POWER** simultaneously. *FUNC 1* displays.
2. Press **USER** to scroll to *UNIT*.
3. Press **TARE** to enter *UNIT*.
4. Press **USER** to toggle between lb and kg.
5. With the desired choice displayed, press **TARE** to select.
6. Press **ZERO** to save and exit to weighing mode.

## 4.10 Battery Life

1. If the unit is turned off, press and hold **USER** then press **POWER**.  
If the unit is on, press **USER** and **POWER** simultaneously. *FUNC 1* displays.
2. Using the **USER**, scroll to *BLIFE*.
3. Press **TARE**. The currently saved total mode displays.
4. Press **USER** to toggle between the choices.
5. With choice displayed, press **TARE** to select. *FUNC 1* displays.  
Press **ZERO** to save and exit to weighing mode or press **USER** to continue to another setup menu item.

## 5.0 Calibration

The MSI-4260M is calibrated using standard weights. The weight used to calibrate, must be at least 15% of full capacity in order to achieve rated accuracy. For example, use at least a 750 kg test weight to calibrate a 5000 kg capacity scale. Although a single span point is usually adequate for rated accuracy, the MSI-4260M supports Multi-Point calibration with up to four span points plus zero.

There are three kinds of calibration:

- **Standard Calibration** – Used for maintenance and routine calibration. ([Section 5.2 on page 28](#))
- **Initial Calibration** – Used to set up both the capacity and resolution (d) of the scale. It differs from Standard Calibration only in the initial steps. The initial calibration is performed after a calibration reset which completely erases the calibration and setup memory. ([Section 5.3 on page 29](#))
- **C-Cal** – Calculated Constant Calibration. Used when test weights are not available. To use C-Cal, a previously generated C-Cal number must be known. ([Section 5.5 on page 31](#))

### 5.1 Calibration Switch Access

Use the following steps to access the calibration switch on the MSI-4260M if calibrating the unit using either the standard calibration or the C-Cal calibration.

1. Remove the hex seal screw from the MSI-4260M.

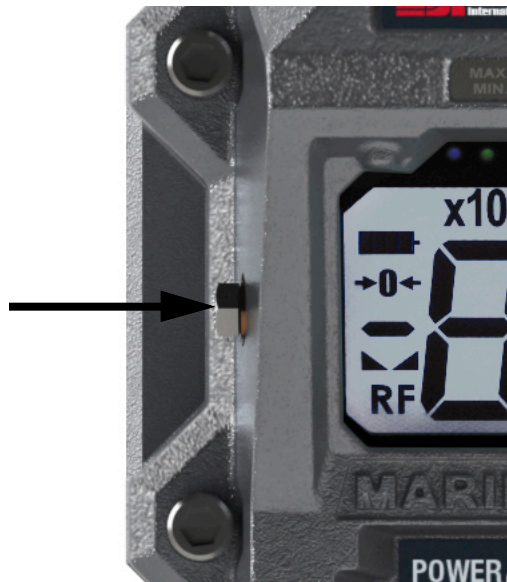





Figure 5-1. Calibration Switch Seal Screw

2. Using a small screwdriver, press the Cal switch located behind the hex seal screw ([Figure 5-1](#)).  $\epsilon RL$  displays.

## 5.2 Standard Calibration

Use the following steps to calibrate the MSI-4260M using the standard calibration procedure.

1. Press Cal switch to initiate Calibration. ([Section 5.1 on page 27](#))
2. Press **TARE** , *U<sub>N</sub>L* displays.
3. Press **TARE**  when the scale becomes motionless, a blinking *□* displays. If the scale is in range *PASS* displays, then *L<sub>o</sub>Rd 1* displays.





 **NOTE:** If *PASS* does not display, what happens?

4. Load the scale with a test weight.





 **NOTE:** For a single span point calibration, a test weight of more than 15% of capacity or more is recommended

5. Press **TARE** . The current capacity flashes on the display.

 **NOTE:** If loading the scale with the capacity weight, skip to [Step 8](#).

6. Press **USER**  to enter the value of the test weight. The far left digit blinks indicating a number should be entered.
7. Press **USER**  to scroll the numbers and **TARE**  to enter each digit as in [Section 1.4.1 on page 9](#).
8. Press **TARE**  to save the weight entry. If the cal value is within limits, *PASS* displays briefly then *L<sub>o</sub>Rd 2*.







 **NOTE:** Display displays *L<sub>o</sub>Rd 3* and *L<sub>o</sub>Rd 4* after the second and third cal values have been entered. After the fourth cal value has been entered, *CAL'* displays. Continue to .

9. If additional cal points are needed, press **TARE**  and repeat steps [Step 4](#) through [Step 8](#) for each additional cal point.
10. When all cal points have been recorded, press **ZERO** . *CAL'* displays to indicate that the calibration was successful.
11. Press **TARE** . *C-CAL* briefly displays followed by the C-Cal number.
12. Press **ZERO**  to store the calibration. *SETUP* displays.
13. Press **ZERO**  to exit the calibration menu. Scale returns to Weigh mode.
14. Replace the hex seal screw that was removed in [Section 5.1 on page 27](#).

### 5.3 Initial Calibration







Use this procedure only if the capacity and count-by (d) needs to be modified. The initial steps of the initial calibration will totally erase user setup as well as any previous calibration.

Use the following steps to calibrate the MSI-4260M using the initial calibration procedure.

1. Turn the MSI-4260M off.
2. Remove the hex seal screw using the steps in [Section 5.1 on page 27](#).
3. Press the **Cal** switch and the **Power** switch on the unit simultaneously. **rESEt** displays.
4. Press **TARE**  to reset the calibration constants. **SURP** displays.
5. Press **TARE**  to confirm. **CAL** displays.
6. Press **TARE**  to start the configuration. **Unit** displays.
7. Press **TARE**  to choose unit.
8. Press **USER**  to toggle between lb and kg.
9. Press **TARE**  to confirm unit. **CAP** displays.
10. Press **TARE**  to set scale capacity. Initial value of **10000** displays.



**NOTE:** 10000 is the initial default value. Capacity should be set no higher than the load cell rated capacity.

11. Press **USER**  to change the capacity. the first digit on the display blinks.
12. Press **USER**  to scroll the numbers and **TARE**  to enter each digit as in [Section 1.4.1 on page 9](#).
13. Press **TARE**  to store the capacity value. **d** displays.
14. Press **TARE**  to choose scale divisions.
15. Press **USER**  to scroll through the recommended scale divisions.
16. Press **TARE**  to select scale division. **Unit d** displays.
17. Calibrate the MSI-4260M as in [Section 5.2 on page 28](#) beginning with [Step 2](#).

## 5.4 Guidelines for Capacity and Resolution

Capacity and resolution are set in the initial calibration of the MSI-4260M.

### 5.4.1 Capacity

Setting capacity is determined primarily by the capability of the load cell.



**NOTE: Never set the capacity of the scale higher than the rating of the load cell.**

It is acceptable to set lower capacities to better match the crane the MSI-4260M is used on. For example, if the hoist is rated for 9000 lb, use an MSI-4260M with 10,000 lb capacity and reset the capacity to 9000 lb so that the scale will indicate overload at 9000 lb instead of 10000 lb. De-rating as much as 50% of the capacity is usually acceptable, but the scale may be less stable if the 'd' is decreased.

Due to kg to lb conversions, the capacity of all MSI-4260M systems is rated approximately 20% higher than the rated capacity in pounds. This is to allow the kg capacity to be exactly 1/2 the number of the pound capacity.

### 5.4.2 Resolution

Due to Legal-for-Trade requirements and general scale design criteria, the weight must be stable for certain features to work:

- ZERO – Weight must be stable to be zeroed
- TARE – Weight must be stable to be tared
- TOTAL – Weight must be stable to be added to the total registers

If the MSI-4260M does not become stable under standard operation, it is recommended that the resolution be reduced and/or filtering increased. Some improvement in stability can be achieved by increasing the filtering ([Section 4.8 on page 26](#)).

Resolution is reduced by increasing the "d" value during initial calibration ([Section 5.3 on page 29](#)). Rice Lake Weighing Systems recommends that the resolution is kept in the 1:2000 to 1:3000 range. Never program the resolution greater than needed.

The third way to increase stability is to increase the **Motion Window**. The MSI-4260M defaults to  $\pm 1d$  as a motion window. It can be changed at Rice Lake Weighing Systems to a higher value if desired. Often  $\pm 3d$  is chosen for bridge cranes as they tend to have a lot of bounce to them. This of course carries an accuracy penalty adding  $\pm 3d$  to the total accuracy of the scale if the zero or tare operation happens to capture the weight in a valley or peak.



**NOTE: Motion Window can only be changed by Rice Lake Weighing Systems.**

## 5.5 C-Cal Calibration











When adequate test weights are not available, the MSI-4260M can be calibrated using a programmed constant calibration number which is referred to as C-Cal. To perform C-Cal, a C-Cal number must be known from a previous calibration. MSI supplies replacement load cells for the MSI-4260M with the C-Cal value stamped on the serial number label. When a calibration is performed with test weights, a new C-Cal is generated. C-Cal can be used when the electronics are replaced to get an approximate calibration that may be suitable for non L-F-T applications.



**IMPORTANT:** The C-Cal number must be known prior to starting this procedure. For a MSI-4260M with its original load cell, MSI prints this number on the calibration record, the serial number tag and on the calibration log found inside the battery compartment.

C-Calibration can be done if the electronics are replaced or a new load cell is installed. C-Cal reduces the absolute accuracy of the system and is intended for non-critical use only. Legal-for-Trade installations require that the MSI-4260M is calibrated using test weights. If a system was originally multi-point calibrated, the C-CAL calibration will erase the additional span points, as C-Cal is only a two point calibration (zero and span at 10% of capacity).

Use the following steps to perform a C-Cal calibration.

1. Remove the hex seal screw from the MSI-4260M and enter the calibration menu using the steps from [Section 5.1 on page 27](#).
2. Press **USER**  to scroll to the C-Cal menu selection.  $\square - \square RL$  displays.
3. Press **TARE**  to start the C-Cal procedure.  $UnLd$  displays.
4. Remove all weight from hook.
5. Press **TARE**  to set the zero calibration point. A flashing  $\square$  displays.
6. If the zero is in range,  $PASS$  displays, followed by  $\square \square RL \square$
7. Press **TARE**  to confirm.
8. Press **USER**  to enter the C-Cal value. The first digit on the display blinks.
9. Press **USER**  to scroll the numbers and **TARE**  to enter each digit as in [Section 1.4.1 on page 9](#).
10. Press **TARE**  to save the C-Cal value.  $PASS$  displays, followed by  $\square RL \square$ .
11. Press **ZERO**  to exit C-Cal setup menu and
12. Press **ZERO**  again to store the calibration and return to the scale operation.  $StorE$  displays.

## 5.6 Calibration Setup Menu

Remove the hex seal screw from the MSI-4260M and enter the calibration menu using the steps from [Section 5.1 on page 27](#).

The Calibration Setup menu contains two additional items beyond Calibration:

- Standard menu
- Auto Zero Maintenance menu (AULZM).

In addition, more menus will appear that are transferred from the main setup menu when Legal-for-Trade settings are used.

Selection	Description
Industrial (INDUS)	This is the most common setting for the MSI-4260M; With the Industrial standard, you have full range zero, access to units switching, filters, and peak hold
Handbook 44 (HB-44)	Sets the scale to enable only approved features per the NTEP HB-44 rules and regulations; Access is denied to Peak Hold, and the zero range may be limited; The Filter menu is moved to the Cal Setup menu, so filters are only accessible through the Cal Seal
R-76 (R-76)	Sets the scale to enable only approved features per OIML R-76; Only kg weight units are available; The zero range is limited to 4% (-1 to +3% relative to Calibrate zero); Net/Gross function is temporary; Once Net weight is established, pushing an F key set for Net/Gross will cause a maximum 5 second display of the Gross weight; You must clear the Tare to display Gross weight constantly; Other metrological aspects are changed to meet R-76 requirements; Only stable weights may be printed; Negative weight display is limited to -20d
One Unit (UNIT)	The one unit Standard is exactly the same as Industrial, except units switching is inhibited; This is useful for Metric only countries; Another use of the One Unit standard is to allow the scale to be calibrated in units other than lb or kg, since conversions are eliminated; Contact MSI for more information on the Standards settings

Table 5-1. Standard Menu Selections

Use the following steps to set up a Legal-for-Trade standard settings.

1. Remove the hex seal screw from the MSI-4260M using the steps from [Section 5.1 on page 27](#) and  $\square$ RL displays.
2. Press **USER**  $\leftrightarrow$   $\rightarrow$ . *SEELUP* displays.
3. Press **TARE**  $\leftrightarrow$   $\uparrow$  to enter the Cal setup menu.
4. Press **TARE**  $\leftrightarrow$   $\uparrow$  to enter the standard menu. The current standard setting displays.
5. Press **USER**  $\leftrightarrow$   $\rightarrow$  to scroll to the desired standard. *UNIT* displays.
6. Press **TARE**  $\leftrightarrow$   $\uparrow$  to set the standard. *AULZM* or the next item in the CAL setup menu displays.
7. Press **ZERO**  $\rightarrow$   $\rightarrow$  twice to exit setup and store all changes. *SEOE* displays.



## 5.7 Auto Zero Maintenance

The MSI-4260M employs an auto-zeroing maintenance mechanism to adjust the zero reading to the center-of-zero (COZ). COZ is defined as the weight reading is within 1/4 'd' of zero. AZM continuously adjusts zero to maintain COZ.

It is recommended that AZM is on to maintain the highest accuracy. However, there are circumstances when it should be turned off. This can happen when minor variations of weight occur while picking up scale attachments and the variations fall within the AZM capture window. The AZM capture window (usually 1 'd') and capture time (usually eight seconds) can be adjusted by MSI to meet custom requirements. The settings of AZM are dictated in Legal-for-Trade standards and cannot be adjusted.

Use the following steps to set up the auto zero maintenance.

1. Remove the hex seal screw from the MSI-4260M using the steps from [Section 5.1 on page 27](#) and  $\overline{LRL}$  displays.
2. Press **USER**  $\leftrightarrow$   $\overline{F}$ .  $\overline{SETUP}$  displays.
3. Press **TARE**  $\leftrightarrow$   $\overline{\uparrow}$  to enter the Cal setup menu.  $\overline{STAND}$  displays.
4. Press **USER**  $\leftrightarrow$   $\overline{F}$  to scroll to the Auto0 menu.  $\overline{AUTO0}$  displays.
5. Press **TARE**  $\leftrightarrow$   $\overline{\uparrow}$  to enter the Auto Zero menu. The current setting (blinking) displays.
6. Press **USER**  $\leftrightarrow$   $\overline{F}$  to scroll between the on or off key.
7. Press **TARE**  $\leftrightarrow$   $\overline{\uparrow}$  to set the auto zero.  $\overline{STAND}$  displays.
8. Press **ZERO**  $\rightarrow$   $\overline{0}$  twice to exit setup and store all changes.  $\overline{STORE}$  displays.

## 5.8 Filter

Changing the filter settings allows the scale to adjust to situations where there is a lot a movement in the structure. If the reading is not stable, it can often be improved by increasing the filter setting. Settling time will be longer as the filter setting is increased. However, the MSI-3460C employs algorithms that speed up large weight changes while still controlling vibration even with high filter settings. Selections are  $\overline{OFF}$ ,  $\overline{LD}$  and  $\overline{HIL}$ .

1. Enter **Configuration** mode ([Section 5.1 on page 27](#)).  $\overline{LRL}$  displays.
2. Press **USER**  $\leftrightarrow$   $\overline{F}$  to scroll to  $\overline{SETUP}$ .
3. Press **TARE**  $\leftrightarrow$   $\overline{\uparrow}$ .  $\overline{STAND}$  displays.
4. Press **USER**  $\leftrightarrow$   $\overline{F}$  to scroll to  $\overline{FILTER}$ .
5. Press **TARE**  $\leftrightarrow$   $\overline{\uparrow}$ . The current setting displays.
6. Press **USER**  $\leftrightarrow$   $\overline{F}$  to scroll to desired setting.
7. When desired value is displayed, press **TARE**  $\leftrightarrow$   $\overline{\uparrow}$ .  $\overline{STAND}$  displays.
8. Press **ZERO**  $\rightarrow$   $\overline{0}$  twice to save settings.  $\overline{STORE}$  displays briefly and exits setup.

## 5.9 Gravity Compensation

Gravity Compensation allows for calibrating in one geographic location for use in a different geographic location. Gravity can be set to OFF, ON, or Factor.

Parameter	Choices	Description	
OFF		Gravity compensation disabled	
ON	--	Calculates Gravity compensation using the origin and destination latitudes and elevations	
	LRtOr	0-90	Latitude of Origin - Original latitude (to nearest degree) for gravity compensation; 47 (default)
	ELtOr	-9999-9999	Elevation of Origin - Original elevation (in meters) for gravity compensation; 10 (default)
	LRtdt	0-90	Latitude of Destination - Destination latitude (to nearest degree) for gravity compensation; 47 (default)
	ELtdt	-9999-9999	Elevation of Destination - Destination elevation (in meters) for gravity compensation; 10 (default)
FACTOr	--	Calculates gravity compensation using origin and destination gravity factors	
	FRcOr	9.00000-9.99999	Gravity of Origin - Original gravity factor (in m/s <sup>2</sup> ) for gravity compensation; 9.8080 (default)
	FRcdt	9.00000-9.99999	Gravity of Destination - Destination gravity factor (in m/s <sup>2</sup> ) for gravity compensation; 9.8080 (default)

Table 5-2. Gravity Compensation Parameters



**NOTE:** To find the local gravity, enter the latitude and elevation into the International Gravity Formula. Listed are links to websites that can be used to determine local latitude and elevation. Please note these website addresses are provided for reference only and may change.

Map Coordinates uses Google maps to find latitude and elevation: [www.mapcoordinates.net/](http://www.mapcoordinates.net/)

Once local latitude and altitude have been determined, use the following link to calculate local gravity <http://www.sensorson.com/local-gravity-calculator/>













**IMPORTANT:** The gravity correction function has not been evaluated by an approvals agency, therefore it is up to the authorized scale dealer to ensure the device is accurate at the intended point of use.

### 5.9.1 Compensation by Latitudes and Elevations

1. Enter **Configuration** mode (Section 5.1 on page 27). **CR**L displays.
2. Press **USER** to scroll to **SEtUP**.
3. Press **TARE** . **SEtAnd** displays.
4. Press **USER** to scroll to **CRcO**.
5. Press **TARE** . The current setting displays.
6. Press **USER** to scroll to **ON**.
7. Press **TARE** . **LRtOr** displays.
8. Press **USER** to enter latitude of origin.
9. Press **TARE** . **ELtOr** displays.
10. Press **USER** to enter elevation of origin.
11. Press **TARE** . **LRtdt** displays.
12. Press **USER** to enter latitude of destination.
13. Press **TARE** . **ELtdt** displays.
14. Press **USER** to enter elevation of destination.
15. Press **TARE** to accept elevation of destination.
16. Press **ZERO** twice to save settings. **SEtOrE** displays briefly and exits setup.

### 5.9.2 Compensation by Gravity Factor

1. Enter **Configuration** mode ([Section 5.1 on page 27](#)). **CAL** displays.
2. Press **USER**  to scroll to **SEtUP**.
3. Press **TARE** . **SEtPd** displays.
4. Press **USER**  to scroll to **GrAViD**.
5. Press **TARE** . The current setting displays.
6. Press **USER**  to scroll to **FACtOr**.
7. Press **TARE** . **FACtOr** displays.
8. Press **USER**  to enter original gravity factor.
9. Press **TARE** . **FACtOr** displays.
10. Press **USER**  to enter destination gravity factor.
11. When desired value is displayed, press **TARE** .
12. Press **ZERO**  twice to save settings. **StORt** displays briefly and exits setup.

## 6.0 Communications

The MSI-4260M can communicate with peripheral devices using 802.15.4, or 802.11/b, g, n Wi-Fi.

The 802.15.4 transceiver is used to communicate between the MSI-4260M and Scale Core Remote Display. The 802.15.4 transceiver is also capable of connecting to any supported device with an 802.15.4 Modem. 802.15.4 operates in the 2.4 GHz ISM band and does not require the end user to obtain a license. 802.15.4 can coexist with other 2.4 GHz systems if caution is taken to isolate antennas at least 10 ft (3 m) from the crane scales and if a Scale Core Remote Display acts as the network coordinator.

The 802.11 Wi-Fi option communicates directly with a standard RF access point. This option is covered by the Wi-Fi for ScaleCore User Guide.



**IMPORTANT:** Unit comes preconfigured from the factory. Any changes will affect factory configuration. Consult Rice Lake Weighing Systems before changing any of these settings.

Name	Description	Recommended Number Range
ScaleCore ID	Used to identify each device in a piconet, its range is 0–254 and cannot be duplicated within the same RF channel	20–30
RF Channel	Establishes the base network that all interconnected devices must match	12–23
Network ID	A 64-bit number that all interconnected devices must match, do not use a small number to avoid other 802.15.4 transceivers that default to a network ID of 0	Maximum of five digits with a range of 0–65535

**NOTE:** For all devices that interconnect, the RF channel and network ID must match. The ScaleCore ID must be unique. The Dyna-Link or crane scale that is the weight source should be set to a ScaleCore ID of 0. If other source devices are added, they can be added in sequence.

Table 6-1. Piconet Setup Ranges

### 6.1 Communications Menu

1. Press **TARE** and **USER** at the same time to enter the Communication menu. *Print* displays.

Parameters	Settings	Description
<i>Print</i>	--	Print – Prints a ticket if connected to a printer (Table 6-3 on page 37)
<i>RF</i>	--	Radio Frequency – See Table 6-7 on page 40

Table 6-2. Communications Menu Parameters

## 6.2 Printer Setup

The RS-232 communications port is capable of outputting load data. Several RF linked device weight modes are available in user formatted form. The control mode directs the MSI-4260M to print ([Section 6.2.1](#)).

The communications port settings are independent of print settings in connected scales. They are only in the MSI-4260M.

1. Press **TARE** and **USER** at the same time to enter the Communication menu. *Print* displays.
2. Press **TARE** to enter the Print Menu. *Print* displays

Settings	Description
<i>Print</i>	Print Setup – Select the channel the port will be used with; Options: 0, 1, 2
<i>Port-P</i>	Port Selection – Select the port to use for communication with the printer; Options <i>Port 0</i> , <i>RF</i> , <i>Port 2</i>
<i>String</i>	String Setup – Print string format number entry screen ( <a href="#">Table 6-6</a> )
<i>Control</i>	Print Control Options: <i>USER</i> , <i>LOAD</i> , <i>Cont</i> , <i>OFF</i> ( <a href="#">Table 6-4</a> )
<i>Rate</i>	Output Rate – Print string output rate number entry screen (0–65535 seconds)

Table 6-3. Print Setup Parameters

### 6.2.1 Control Modes

The user can select four control modes. They are described in [Table 6-4](#).

Mode	Description
<i>USER</i>	Printing is controlled by pressing <b>F-3 Print</b>
<i>LOAD</i>	One print occurs when a stable load is read, the scale must return to near zero before another print occurs <b>NOTE: Other configurations of load are available using the ScaleCore Connect. It can be downloaded from the Rice Lake Weighing Systems Website.</b>
<i>Cont</i>	The unit will continuously output the data at a rate specified in the rate parameter (up to 65,535 seconds); Setting the interval to 0 will set an interval as fast as the system can go
<i>OFF</i>	Printing is disabled; Power consumption is lower with the print off

Table 6-4. Control Modes

## 6.2.2 Standard Print Strings

Commands that can be used to format gross, net and print strings are shown below.

Command	Description
<T>	Load data
<U>	Units (lb/kg)
<M>	Load mode (gross/net)
<CRLF>	Carriage return line feed
<SP>	Space
<STX>	Start of text character (ASCII 2)
<P>	Space for positive, - for negative
<W7.>	7-digit weight, floating decimal, leading spaces
<S>	Status, upper case: <SP> =OK, M=Motion, O=Overload, Z=Zero, I=Invalid

Table 6-5. Print String Commands

Print String Number	Parameter	Description
1	Current load	Fixed output length: 16; Leading zeros suppressed except for the least significant digit (LSD) <TTTTTT><SP><UU><SP><MMMMM><CRLF>
2	Net load	Fixed output length:16; Leading zeros suppressed except for the LSD <TTTTTT><SP><UU><SP>NET<SP><SP><CRLF>
3	Gross load	Fixed output length: 16; Leading zeros suppressed except for the LSD <TTTTTT><SP><UU><SP>GROSS<CRLF>
4	Tare Weight	Fixed output length: 16; Leading zeros suppressed except for the LSD <TTTTTT><SP><UU><SP>TARE<CRLF>
5	Total Weight	Fixed output length: 16; Leading zeros suppressed except for the LSD <TTTTTT><SP><UU><SP>TTL<CRLF>
6	Number of Samples Totaled	Fixed output length: 16; Leading zeros suppressed except for the LSD <SP><SP><SP><SP><SP><SP><SSSSSS><SP><T-CNT>SP<CRLF>
7	Rice Lake / Condec:	Stream Data Format; <STX><P><W7.><U><M><S><CR><LF>
8/9	Carriage Return/Line Feed	Used to add a space between print records; <CRLF>

Table 6-6. Standard Print Strings



**NOTE:** If unit is in legal for trade mode (r76-HB44) the only print string available is number 1.

Combinations of the standard print strings can be entered in the string number entry screen.

*Example: To get a Net, Gross, Tare printout with a space between records, enter 2349.*

### 6.2.3 Printer Output Setup

Use the following steps to set up the printer output.

1. Press **TARE** and **USER** at the same time. *Print* displays.
2. Press **TARE**. *LSLn* displays.
3. Press **TARE**. The current setting flashes.
4. Press **TARE**. *OUT-P* displays.
5. Press **TARE**. The current setting flashes.
6. Press **USER** to toggle between *PORT0* and *RF*.
7. When the desired setting displays, press **TARE**. *SErnc* displays.
8. Press **TARE** to enter.
9. Enter the number using **USER** to scroll through numbers and **TARE** to set the string number desired. (Section 6.2.2 on page 38)
10. When set, press **TARE** again. *cntrl* displays.
11. Press **TARE** to enter. Current setting flashes.
12. Press **USER** to scroll through the settings. (Section 6.2.2 on page 38)
13. When desired setting displays, press **TARE**. *rRE* displays.
14. Press **TARE** to enter.
15. Enter the number using **USER** to scroll through numbers and **TARE** to set number.
16. Press **TARE** again. *LSLEn* displays.
17. Press **ZERO** twice to save settings. *SEORE* displays briefly and exits setup.



**NOTE:** When entering numbers, pressing **ZERO** will step back a digit for corrections.

### 6.2.4 Custom Print Formatters

The ScaleCore Connect application is used to create custom output formatters. Download the ScaleCore Connect software from the Rice Lake website. For more information see the ScaleCore Connect software manual (PN 185725).

Custom formatters are also configured in the ScaleCore Webserver. For more information, see the ScaleCore Webserver technical manual (PN 208738).

The serial output is configured as 9600 baud, Xon/Xoff handshaking, no hardware handshaking, 1 stop bit, no parity.

Other baud rates are possible by special order only.

## 6.3 RF Network Setup

The MSI-4260M uses 802.15.4 transceivers to communicate with Scale Core Compatible another supported device with an 802.15.4 Modem.



**NOTE:** Ensure a relatively clear transmission path exists between the devices to be connected. Radio signals travel primarily by line of sight (LOS), obstructions between stations may degrade the system performance.

The red LED annunciator on the right represents standby mode is active when the scale is turned off. Standby is enabled if the radio is enabled and the scale is turned off. Radio remains powered when the scale is powered off, reducing battery life, but allows for the scale to be remotely turned on by the RF remote control.



Figure 6-1. Standby LED

### 6.3.1 MSI-4260M 802.15.4 RF Network Setup

When equipped with the 802.15.4 option, the MSI-4260M can connect with Scale Core Compatible Remote Display or another supported device with an 802.15.4 Modem.

Choices	Parameters/Range	Description
On,OFF	On OFF	Enable RF – Affects continuous mode only
Sc id	0- 254	ScaleCore ID – Used to identify each ScaleCore device in a piconet, must not be duplicated within the same RF Channel
Chnl	12- 23	RF Channel – Establishes the base network that all interconnected devices must match, range 12-23
Net id	0- 99999	Network ID – A 64 bit number that all interconnected devices must match; The MSI-4260M limits this number to a max of 5 digits in a range of 0-99999 <b>Note: Do not use a small number here to help avoid other 802.15.4 networks that default to a Network ID of 0 Range 0-99999</b>
TYPE	ZBEE Other	Connection Type – Type of card being used <b>Note: ZBEE refers to XBee 802.15.4 RF card; Both XBEE 2SC, XBee 3 and XBee 3-Pro use the ZBEE parameter</b>
Hold	On OFF	Setting Hold to On keep power to the radio even when the scale is turned off; This is required if the Rugged Remote or a remote display will be used to turn the MSI-4260M on; This causes some battery to drain when the scale is off; Hold should be set to off unless this is require in order to maximize battery life. (Section 6.3.2 on page 41)

Table 6-7. RF Menu Parameters

To configure RF Network:

1. Press the **TARE** and **USER** keys at the same time. **RF net** displays.



**NOTE:** *busy* may flash momentarily before entering the communications menu.

2. Press **USER**. **RF** displays.
3. Press **TARE**. **On,OFF** displays.
4. Press **TARE** to enter parameter. The current value flashes.
5. Press **USER** until **On** displays.
6. Press **TARE**. **Sc id** displays.
7. Press **TARE**. The current ID flashes. If SCID is correct, continue to [Step 9](#).



8. Enter the ID using **USER** to scroll through numbers and **TARE** to set number.
9. When ID is set, press **TARE** again. **CHNL** displays.
10. Press **TARE**. The current channel flashes. If the channel number is correct continue to [Step 12](#).
11. Enter the channel using **USER** to scroll through numbers and **TARE** to set number.
12. When channel is set, press **TARE** again. **NET ID** displays.
13. Press **TARE**. The current net ID flashes. If the net ID is correct, continue to [Step 15](#).
14. Enter the network ID using **USER** to scroll through numbers and **TARE** to set number.
15. When the Net ID is set, press **TARE** again. **TYPE** displays.
16. Press **TARE** to enter parameter. The current value flashes.
17. Press **USER** until **ZbEE** displays.
18. Press **TARE**. **Hold** displays.
19. Press **TARE** to enter parameter. The current value flashes.
20. Press **USER** until desired setting displays.
21. Press **TARE**. **On. OFF** displays.
22. Press **ZERO** twice to save and exit to **Weigh** mode.

 **NOTE:** When entering numbers, pressing **ZERO** will step back a digit for corrections.

### 6.3.2 Standby Mode

The hold feature is used to keep the modem on even when the display is off. It is used if desired with a rugged remote or a remote display.

 **NOTE:** When standby mode is enabled and the scale is powered off, the red standby LED will turn on in the upper left corner to indicate that hold mode is active and the scale is still drawing power.

*This LED is described in section 6.3.*

To Enable it follow these steps:

1. Press **TARE** and **USER** simultaneously. **Pr net** displays.
2. Press **USER**. **rF** displays.
3. Press **TARE**. **On. OFF** displays.
4. Press **TARE** to enter **On. OFF**.
5. Press **TARE** to select **On**.
6. Press **USER** to scroll to **Hold**.
7. Press **TARE** to enter the **Hold**.
8. Press **TARE** to select **On**.

Press **ZERO** twice to store settings and return to Weigh mode.

## 7.0 Optional Rugged Remote

The MSI-4260M with an installed RF modem can be controlled with an optional Rugged Remote (PN 173014). The Rugged Remote is a transmit only device that can be used to perform basic scale functions. The range may vary up to 100' or more depending on room conditions and line of sight.

The RF modem in the MSI-4260M must be configured to accept communication from the Rugged Remote, contact Rice Lake Weighing Systems for pairing requirements.



**NOTE:** A Rugged Remote is paired to an individual device and cannot be reprogrammed in the field.



Figure 7-1. Rugged Remote

### 7.1 Operation

The Rugged Remote is paired to a single ScaleCore RF device and replicates the front panel buttons. Slight variations between each device's buttons will result in different operation in the Rugged Remote. See Table 7-1 for corresponding buttons for the Rugged Remote and the connected device.



**NOTE:** The Rugged Remote can only be paired to a single ScaleCore device. Reprogramming to configure communication to a different ScaleCore device can only be performed at the factory or with the purchase of additional RF modems.

Rugged Remote	MSI-4260M	Description
		Power
		Zero
		Tare/Function 1
		User/Function 2

Table 7-1. Corresponding Buttons

### 7.1.1 Power

The Rugged Remote can be enabled to turn on and off the ScaleCore device it is paired remotely. The hold function must be enabled in the MSI-4260M ([Section 6.3.2 on page 41](#)).



**NOTE:** *The Hold feature causes the device's modem to stay on and continuously draw from the battery, even when the device is turned off, resulting in decreased battery life.*

### 7.1.2 Zero

Press  to remove small deviations in zero when the MSI-4260M is unloaded ([Section 3.2 on page 18](#)).

This key is not programmable.

### 7.1.3 Programmable Function Keys

Tare/F1 and FCN/F2 (pictures of buttons) are programmable in the MSI-4260M. Function 1 is defaulted to Peak hold and Function 2 is defaulted to Test in the MSI-4260M. See [Section 4.2 on page 23](#) to configure the MSI-4260M function keys for Rugged Remote operation.

## 7.2 Conflict and Jamming Considerations

It is important to understand that only one transmitter at a time can be activated within a reception area. While the transmitted signal consists of encoded digital data, only one carrier of any frequency can occupy airspace without conflict at any given time. This is not to say that there cannot be multiple remote controls for the unit, but rather that two cannot be used simultaneously.

## 7.3 FCC Compliance

The Rugged Remote has 802.15.4 certification ([Section 1.2 on page 7](#)).

## 8.0 Troubleshooting/Maintenance

Problem	Possible Cause	Solution
The display is blank when the <b>POWER</b> button is depressed	Discharged battery	Recharge the battery; Allow at least four hours charge
	Defective battery	Replace the battery
	Corroded battery or battery contacts	Clean the battery contacts
	Defective switch or circuit board	Requires authorized service
30 second delay during power up	RF set to "ON" with no radio installed	Set RF to "OFF" See <a href="#">Section 6.1 on page 36</a>
The display does not function properly, the front panel button does not function normally or the scale will not turn off	Improperly updated software	Reinstall the software
	Faulty circuit board	Requires authorized service
	Loose connectors	Requires authorized service
The scale does not respond to weight changes	Out of calibration	Calibrate the unit
	Faulty load cell	Replace the load cell
	Load cell connector	Check the connector and wires
The display over ranges below 100% capacity	Tared weight is added to load to determine overload point	Return to gross Weigh mode
	Zero requires adjustment	Rezero the scale
	Too much weight has been zeroed	Rezero the scale
The display drifts	AZM (Auto0) is turned off	Turn AZM on
	Rapid temperature changes such as moving the scale from indoors to outdoors	Wait until the scale temperature has stabilized
	Bad load cell	Check load cell and load cell wiring
The displayed weight shows a large error	Scale not zeroed before load is lifted	Zero the scale with no load attached
	lb/kg units causing confusion	Select the proper units
	Requires recalibration	Recalibrate the unit
	Damaged load cell	Check load cell and load cell wiring
The display reading is not stable	Excessive vibration in crane system	Increase filtering or increase 'd' in Cal
	Excessive side loading	Improve load train symmetry
	Load cell faulty	Check the load cell connections
The display toggles between "Error" and "Load"	Weight exceeds capacity	Reduce weight immediately
	Calibration Faulty	Recalibrate
	Faulty load cell or wiring	Check load cell and load cell wiring
The display toggles between "Error" and "UnLd"	Weight in below the zero range	If the scale is in compression, remove the source
	Calibration faulty	Recalibrate
	Faulty load cell or wiring	Check the load cell connections
Display toggles between "Error" and "A2DLo"	A/D is saturated negative	Check the load cell and load cell wiring
Display toggles between "Error" and "buttn"	A key is stuck or is being held down	Check switches for damage
Rugged Remote does not work	Units are not paired	See <a href="#">Section 6.3 on page 40</a>
Some Rugged Remote keys do not work but the ACK light blinks	The keys were not enabled during the setup process	Enable the keys by running the transmitter and receiver address procedures
Lo Batt is blinking	The battery is low	Recharge the battery
Unit turns on, then immediately turns off	The battery is low	Recharge the battery
Weight will not zero	The system not stable	The stable annunciator must turn on for Zero to function; Increase the filtering for more stability
	Zero is out of range	Legal-for-Trade units have limited zero range; Reduce the weight or use Tare instead
The weight will not Zero, Tare or Total	The system is not stable	Wait for Stable annunciator to turn on, or if in a mechanically noisy crane, increase the filtering or increase the size of the scale increment "d". It is also possible to increase the motion window; Contact MSI if you have a problem getting the MSI-4260M to zero, tare, or total due to stability issues
Setpoint lights blink	Setpoint enabled and trigger point reached	Disable set points if they are not needed
Manual total does not work	A Function key is not set to "Total"	Set up Func1 or Func2 for "Total"
	The weight must be stable	Increase filtering for more stability
Auto Total does not work	The weight must be stable	Wait for the stable annunciator to turn on, or Increase filtering for more stability
	Weight thresholds not reached	Must exceed 1% of capacity for autototal to work; Must drop below 0.5% of capacity for additional weighments to register

Table 8-1. Troubleshooting

## 8.1 Service Counters



**IMPORTANT:** Only a Rice Lake Weighing Systems factory representative can reset the service counters, as these are an important safety warning feature. A thorough load train inspection is necessary to ensure product safety.

Service Counters are important safety warning features and can only be reset at the factory by certified Rice Lake personnel.

As part of the reset process, the service technician will perform a thorough load train inspection to ensure user safety and confirm that the product is ready to be returned for regular service.

See the *Crane Scale Safety and Periodic Maintenance Manual (PN 153105)* for proper loading techniques to improve the safety and longevity of your MSI Overhead Weighing Product. Download the *Crane Scale Safety and Periodic Maintenance Manual (PN 153105)* at [www.ricelake.com](http://www.ricelake.com).

The MSI-4260M maintains two service counters for safety.

- The first one counts the number of times the scale has been overloaded
- The second counter counts lifts above 25% of capacity

These counters serve to warn the user to inspect the load train after a number of overloads, also when there is a chance of fatigue failure. The power up routine will be interrupted when the lift counter exceeds 16383 lifts or the overload counter exceeds 1023 overloads. If the screen displays  $LF\overline{C}nt$  when unit is powered on:

1. Press **TARE**  $\leftrightarrow$   $\uparrow$  to display the 25% lift counter.
2. Press **TARE**  $\leftrightarrow$   $\uparrow$  again to see the overload lift counter.
3. Press **ZERO**  $\rightarrow$   $\downarrow$  to acknowledge the warning and return to standard scale operation.



**NOTE:** The power up warning message will not appear for another 16383 lifts (or 1023 overloads).

### 8.1.1 Access the Service Counters

Use the following steps to access the service counters.

4. Program a user function key to be  $\overline{E5E}$  (Section 4.2 on page 23)
5. Press **USER**  $\leftrightarrow$   $\uparrow$ .
6. Press **TARE**  $\leftrightarrow$   $\uparrow$ . The display flashes.
  - $LF\overline{C}nt$  (Lift Counter) followed by the number of times the weight has exceeded 25% of capacity
  - $\overline{OL}nt$  (Overload Counter) followed by the number of times the weight has exceeded capacity
  - $\overline{C-}CAL$  (C-Calibration) followed by the C-Cal value

The display returns to the **Weighing** mode.

To stop the scrolling and step through them slowly proceed to [Step 7](#).

7. Press **USER**  $\leftrightarrow$   $\uparrow$  immediately after **TARE**  $\leftrightarrow$   $\uparrow$  is pressed.
8. Press **USER**  $\leftrightarrow$   $\uparrow$  to scroll through counters.
9. Press **TARE**  $\leftrightarrow$   $\uparrow$  to enter the counter, the value displays.
10. Press **ZERO**  $\rightarrow$   $\downarrow$  to return to **Weighing** mode.



**NOTE:** After the service counters are viewed, automatic warnings stop, but the counters continue to monitor lifts.

## 8.2 Dimensions

### 8.2.1 MSI-4260M Port-A-Weigh Marine Scale

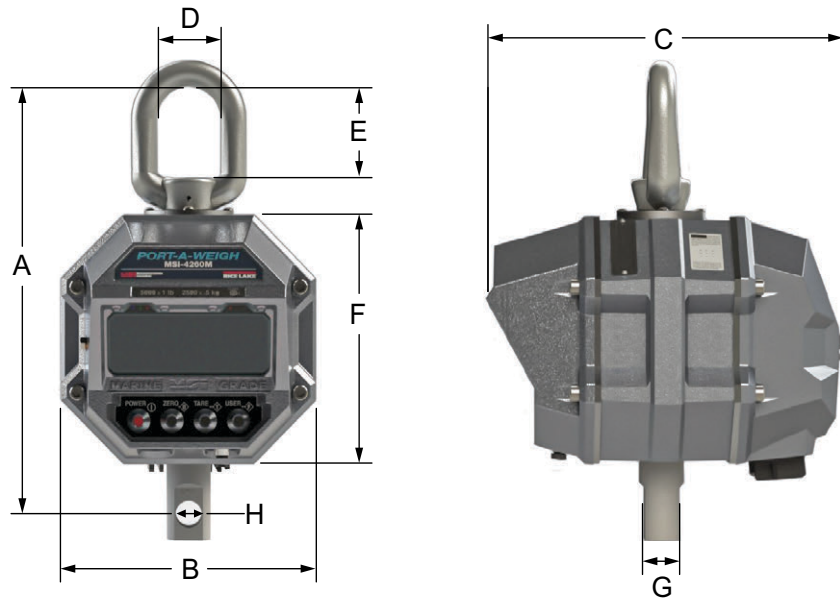

Figure 8-1. Product Diagram

A	B	C	D	E	F	G	H
16.28" (413.5 mm)	10.00" (254.0 mm)	13.52" (343.4 mm)	2.50" (63.5 mm)	3.50" (88.9 mm)	9.28" (235.7 mm)	1.35" (34.3 mm)	Ø 1.03" (26.1 mm)

Table 8-2. Product Dimensions (PN 194593)

### 8.2.2 MSI-4260M Port-A-Weigh Industrial Scale

12V and AC Power Versions

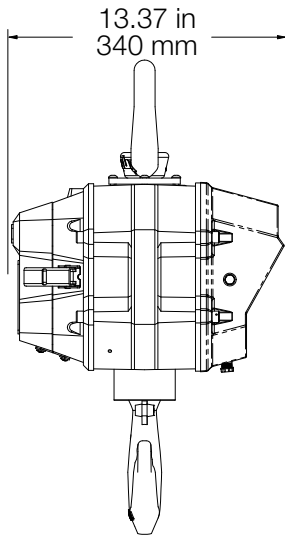

D-Cell Battery Power Version

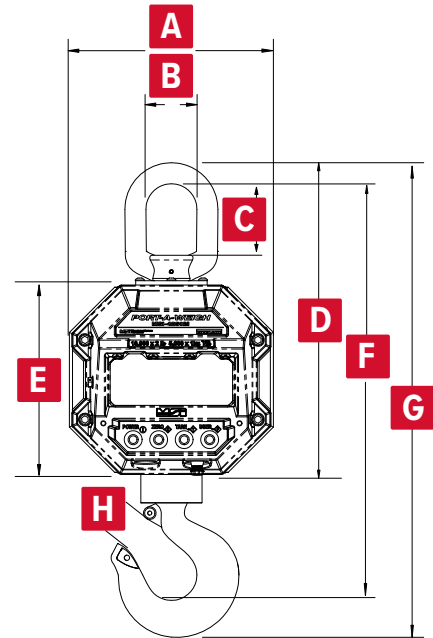
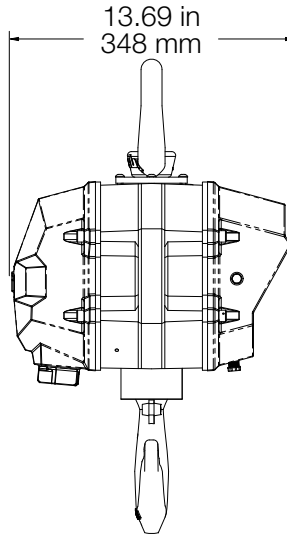

Figure 8-2. Product Diagram

Capacity	Resolution	A	B	C	D	E	F	G	H	Safety Factor	Estimated Ship Weight
500 lb / 250 kg	0.2 lb / 0.1 kg	10 in 254 mm	2.25 in 57 mm	3.06 in 78 mm	14.49 in 368 mm	9.28 in 236 mm	18.9 in 480 mm	21.26 in 540 mm	1.5 in 38 mm	>5	53 lb 24 kg
2,000 lb / 1,000 kg	1.0 lb / 0.5 kg										
5,000 lb / 2,500 kg	1.0 lb / 0.5 kg	10 in 254 mm	2.50 in 64 mm	3.5 in 89 mm	15.28 in 388 mm	9.28 in 236 mm	20.5 in 521 mm	23.25 in 591 mm	1.78 in 45 mm	>5	62 lb 28 kg
10,000 lb / 5,000 kg	2.0 lb / 1.0 kg										
20,000 lb / 10,000 kg	5.0 lb / 2.0 kg	10 in 254 mm	4.10 in 104 mm	6.11 in 155 mm	19.13 in 486 mm	9.28 in 236 mm	28.4 in 721 mm	32.58 in 828 mm	2.62 in 67 mm	>7 >6.5	105 lb 47 kg
30,000 lb / 15,000 kg	10.0 lb / 5.0 kg						30.1 in 765 mm	34.73 in 882 mm	3.41 in 87 mm	>5	125 lb 55 kg
50,000 lb / 25,000 kg	10.0 lb / 5.0 kg	10 in 254 mm	5 in 127 mm	6 in 152 mm	22.35 in 568 mm	9.40 in 239 mm	41.7 in 1059 mm	46.98 in 1193 mm	4 in 102 mm	>5 4.9*	235 lb 106 kg
70,000 lb / 35,000 kg	20.0 lb / 10.0 kg						43.9 in 1115 mm	50.15 in 1274 mm	4.25 in 108 mm	4.75** 4.3**	270 lb 420 kg
100,000 lb / 50,000 kg	20.0 lb / 10.0 kg	10 in 254 mm	5.75 in 146 mm	6.67 in 169 mm	23.62 in 600 mm	9.40 in 239 mm	51.3 in 1303 mm	58.36 in 1482 mm	4.75 in 121 mm	4.5*** 4***	420 lb 189 kg

Table 8-3. Product Dimensions

## 9.0 Specifications

### Accuracy

± (0.1% +1 d) of applied load

### Resolution

Max NTEP Approved Class III: 2,500 Divisions  
Max NTEP Approved Class IIII: 5,000 Divisions  
Max Non NTEP Approved: 10,000 Divisions

### Capacity

5,000 x 1 lb / 2,500 x 0.5 kg

### Enclosure

IP66 cast aluminum

### Lifting Eye and Lower Link

Top lifting eye with lower link interface that will fit a shackle

### Design Overload

200% Safe / 500% Ultimate

### Functions

Power Turns unit on or off  
Zero Zeros applied load up to 100% of capacity (limited rang in NTEP configurations)  
Tare Tares applied load and displays weight in Net mode  
User Programmable as test, total, unit, peak hold, net/gross, view total and print

### Display

Five-digit, 1.75" (44.5 mm) LCD with programmable brightness control

### Displayable Units

Pounds (lb) or kilograms (kg) selectable

### Annunciators

COZ, Battery Level, Net, Total, lb/kg, Stability, Scale Channels, RF and Setpoint LEDs

### Power

Marine Scale - Battery operated, six (6) D cell 1.5 V alkaline batteries  
Industrial Scale - Rechargeable 12V Sealed Lead Acid (SLA) battery

### Operating Time

Up to 1000 hours of battery life with typical use, less with RF option; also depends on display backlight brightness

### Operating Temperature

Legal-for-Trade 14°F– 104°F (-10°C–40°C)  
Operating -20°F–122°F (-28°C–50°C)

### Auto-Off Mode

Powers off after the scale is not used for the set time (in minutes); 15, 30, 45, 60 or OFF selectable

### Auto Sleep Mode

Powers down during non-use after the set time (in minutes) and powers up with weight change or any key press; 5, 15, 30 or OFF selectable

### Service Counters

Counts number of lifts over percentage of capacity and lifts over capacity

### Calibration

Digital (procedure initiated by calibration switch)

### Filtering

OFF, LO, HI-1 or HI-2 selectable

### Radio Link

DSSS (Direct Sequence Spread Spectrum)  
IEEE 802.15.4  
FHSS at 2.4 GHz

### Radio Effective Range

Typically 500' (150 m) indoor, 1000' (300 m) outdoor with standard antennas

### Totalization

Standard: Press button or Automatic;  
TOTAL weight up to 99999 x 1000 kg/lb

### Setpoints

Eight user programmable setpoints. Setpoints 1–3 are visible on the device and LED outputs. Setpoints 4–8 can only be used by connecting a compatible RF remote display.

### Construction

All features are housed in heavy duty, cast aluminum housing consisting of three sections:

- The front section of the scale houses the display, controls and all electronics
- The center section contains the load cell, lifting eye, hook and quick access to the batteries
- The rear section of the scale features quick access to the batteries

### Warranty

One-year limited warranty

### Approvals



#### NTEP

CoC Number 19-122  
Accuracy Class: IIII;  $n_{max}$ : 5000



#### Measurement Canada

AM-6198: 500 to 5,000 lb  
AM-6249: 10,000 to 20,000 lb







© Rice Lake Weighing Systems Content subject to change without notice.

230 W. Coleman St. • Rice Lake, WI 54868 • USA USA: 800-472-6703 • International: +1-715-234-9171