

# Rice Lake VS-33

34 INCHES WIDE

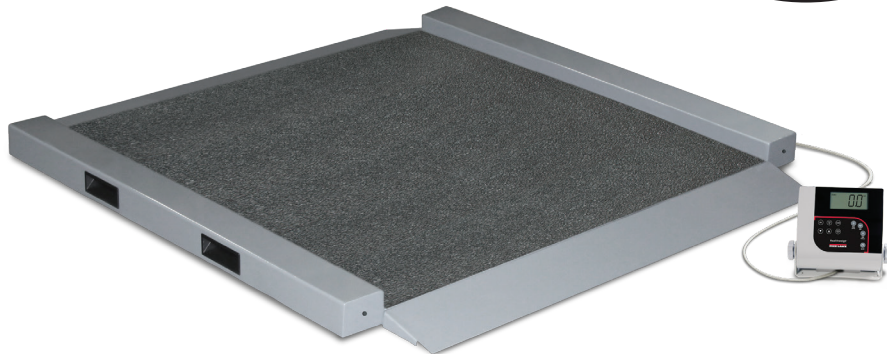

## Standard Features

- Large LCD display
- Antimicrobial keypad
- Integrated handles and wheels for easy transport
- Dual ramp
- Large, stable scale base
- Metal nonslip platform
- Unit of measure toggle or locking
- Motiontrap™ movement compensation technology
- Serial and USB data communication port
- Tare function
- Hold function
- Factory calibrated

## Specifications

### Capacity:

1,000 × 0.2 lb (450 × 0.1 kg)

### Platform Dimensions Without Ramps:

(L × W × H)

34.00 × 34.00 × 2.20 in

### Power:

9 VDC, provided by six AA alkaline batteries (included) or AC adapter (optional)

### Battery Type:

Six AA alkaline (included)

### Battery Use:

25 hours continuous use with batteries  
Automatic power-off can be configured

### Temperature:

Operating:  
50 °F to 104 °F (14 °C to 40° C)

### Cable Length:

9 ft (2.7 m) cable between scale base and indicator

### Display:

5-digit LCD display, 0.75 in (1.9 cm) digit height

### Warranty:

Two-year limited

## Part Number/Price

Part #	Model #	Capacity	Price
204400	Rice Lake VS-33 Double Ramp	1,000 × 0.2 lb (450 × 0.1 kg) with USB	Consult

## Shipping Weight

Part #	Model #	L (in)	W (in)	H (in)	Package Wgt. (lb)	Dim Wgt. (lb)	Shipping Wgt. (lb)
204400	Rice Lake VS-33 Double Ramp	43	43	11	162	147	162

## Options/Accessories

Part #	Description	Price
79074	Cable, USB 6 ft USB-A (male) to USB-B (male)	Consult
217091	Cable, Communication DB9 (female) to RJ45 (male), 4 conductor	Consult
186830	Cable, RS232 scale to printer, 6 ft, 25-pin D-Sub (male) to RJ45	Consult

## Dimensions

	Inches	Centimeters
A	41.00	104.1
B	40.00	101.6
C	2.20	5.6
D	34.00	86.4
E	34.00	86.4
F	3.70	9.4

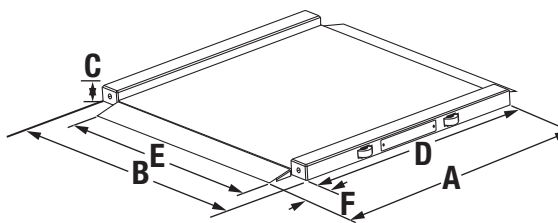

LARGE ANIMAL  
SCALES

# Rice Lake VS-37



Wall mounted indicator,  
cable enclosed in  
customer supplied conduit

## Standard Features

- Package includes scale, pit frame, handrail and indicator
- Large 1-inch LCD display
- Antimicrobial keypad
- Heavy-duty mild steel construction
- Unit of measure toggle or locking
- Motiontrap™ movement compensation technology
- Serial and USB communication port
- Tare function
- Hold function
- Factory calibrated

## Specifications

### Capacity:

1,000 × 0.2 lb (450 × 0.1 kg)

### Platform Dimensions:

(L × W × H)

36.00 × 36.00 × 3.00 in

### Power:

9 VDC, provided by six AA alkaline batteries (included) or AC adapter (optional)

### Battery Type:

Six AA alkaline (included)

### Battery Use:

25 hours continuous use with batteries  
Automatic power-off can be configured

### Display:

5-digit LCD display, 0.75 in (1.9 cm) digit height

### Temperature:

Operating:  
50 °F to 104 °F (14 °C to 40 °C)

### Warranty:

Two-year limited

## Part Number/Price

Part #	Model #	Capacity	Price
204402	Rice Lake VS-37	1,000 × 0.2 lb (450 × 0.1 kg) with USB	Consult

## Shipping Weight

Part #	Model #	L (in)	W (in)	H (in)	Package Wgt. (lb)	Dim Wgt. (lb)	Shipping Wgt. (lb)
204402	Rice Lake VS-37	40	39	15	246	169	246

## Options/Accessories

Part #	Description	Price
79074	Cable, USB 6 ft USB-A (male) to USB-B (male)	Consult
217091	Cable, Communication DB9 (female) to RJ45 (male), 4 conductor	Consult
186830	Cable, RS232 scale to printer, 6 ft, 25-pin D-Sub (male) to RJ45	Consult

## Dimensions

	Inches	Centimeters
A	36.00	91.4
B	36.00	91.4
C	3.00	7.6
D	28.50	72.4
E	31.50	80.0
F	37.00	94.0
G	35.50	90.2

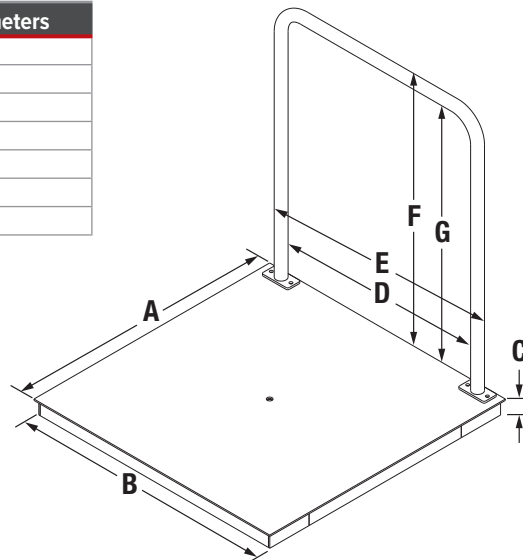

LARGE ANIMAL  
SCALES

# Rice Lake VS-37

## Pit Frame Concrete Details

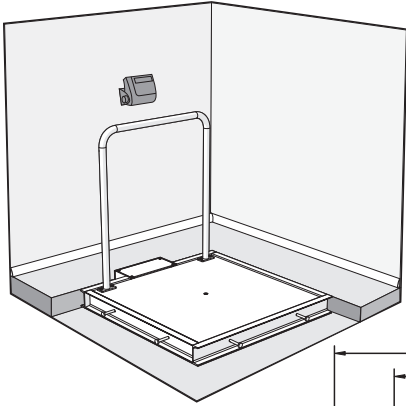
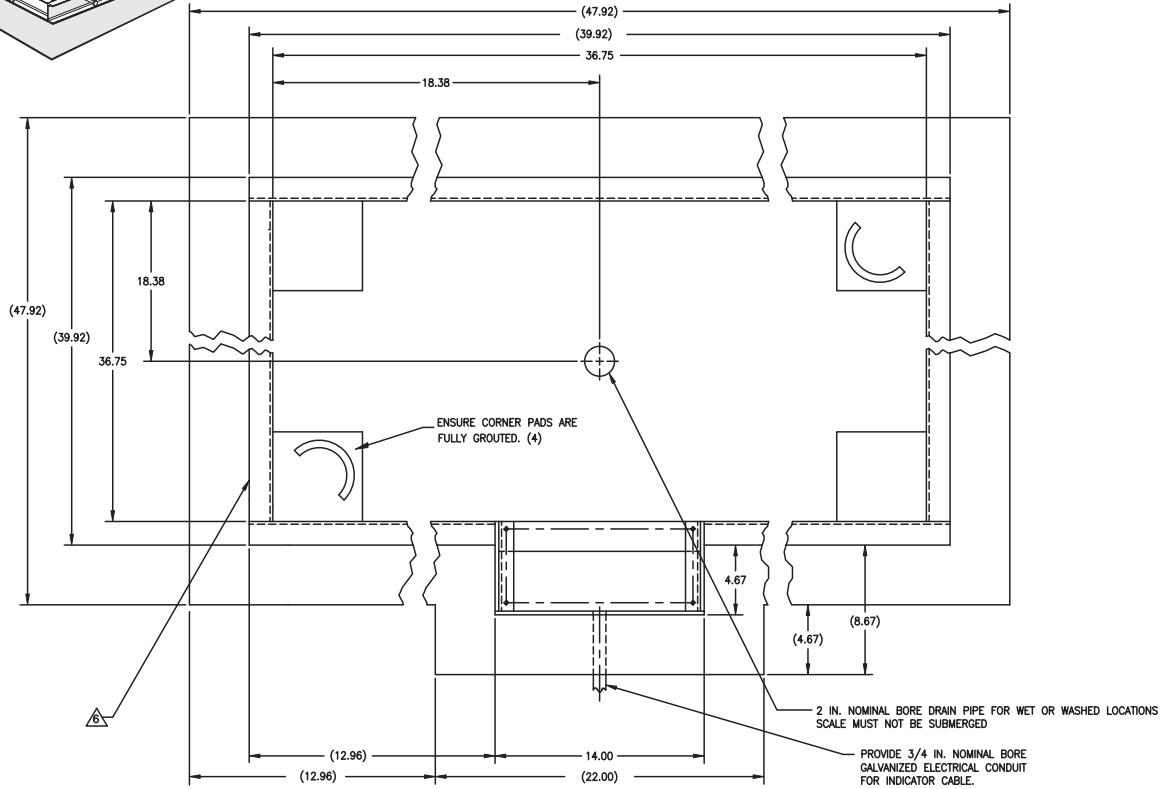
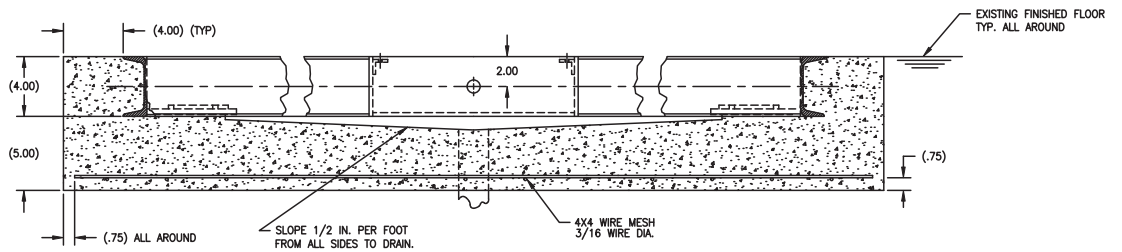

Image illustrates pit frame exposed to show detail.



NOTE: HANDRAIL ON SCALE WILL MOUNT ON SAME SIDE AS JUNCTION BOX POCKET



NOTE:

1. USE CONCRETE OF MINIMUM YIELD STRENGTH 5000 PSI OR 6-BAG MIX.
2. ALLOW 7 DAYS TO CURE. WET CONCRETE PERIODICALLY DURING THIS TIME.
3. DIMENSIONS SHOWN ASSUME FIRM, STABLE SOIL CONDITIONS. WHEN SOIL CONDITIONS ARE NOT ADEQUATE, PLACE FOUNDATION AT SUFFICIENT DEPTH.
4. IN WET OR WASHDOWN APPLICATIONS WE RECOMMEND THE USE OF HERMETICALLY SEALED LOAD CELLS, AND THAT THE JUNCTION BOX BE MOUNTED REMOTELY IN A DRY LOCATION.
5. WIRE MESH TO HAVE MINIMUM .75 COVER BOTTOM AND SIDES.

ON STAINLESS STEEL VERSIONS, TWO PIECES OF 2 INCH ANGLE WILL BE SUBSTITUTED FOR THE 4 INCH CHANNEL.

LARGE ANIMAL SCALES



## Standard Features

- Push-button LCD display
- Antimicrobial keypad
- Two wheels for portability
- Dual ramp
- Metal nonslip platform
- Motiontrap™ movement compensation technology
- Unit of measure toggle or locking
- Serial and USB communication ports
- Tare function
- Hold function
- Factory calibrated

## Specifications

### Capacity:

1,000 × 0.2 lb (450 × 0.1 kg)

### Platform Dimensions Without Ramps:

(L × W × H)  
49.30 × 32.70 × 2.60 in

### Platform Dimensions with Wheels and Ramps:

(L × W × H)  
63.80 × 32.70 × 2.60 in

### Power:

9 VDC, provided by six AA alkaline batteries (included) or AC adapter (optional)

### Battery Type:

Six AA alkaline (included)

### Battery Use:

25 hours continuous use with batteries  
Automatic power-off can be configured

### Display:

5-digit LCD display, 0.75 in (1.9 cm) digit height

### Cable Length:

7 ft (2.1 m) cable between scale base and indicator

### Temperature:

Operating:  
50 °F to 104 °F (10 °C to 40 °C)

### Warranty:

Two-year limited

## Part Number/Price

Part #	Model #	Capacity	Price
204407	Rice Lake VS-40	1,000 × 0.2 lb (450 × 0.1 kg)	Consult

## Shipping Weight

Part #	Model #	L (in)	W (in)	H (in)	Package Wgt. (lb)	Dim Wgt. (lb)	Shipping Wgt. (lb)
204407	Rice Lake VS-40	67.2	36	6	154	104	154

## Options/Accessories

Part #	Description	Price
79074	Cable, USB 6 ft USB-A (male) to USB-B (male)	Consult
217091	Cable, Communication DB9 (female) to RJ45 (male), 4 conductor	Consult
186830	Cable, RS232 scale to printer, 6 ft, 25-pin D-Sub (male) to RJ45	Consult

## Dimensions

	Inches	Centimeters
A	63.80	162.1
B	49.30	125.2
C	32.70	83.1
D	32.90	83.6
E	3.90	9.9
F	2.60	6.7
G	0.55	1.4

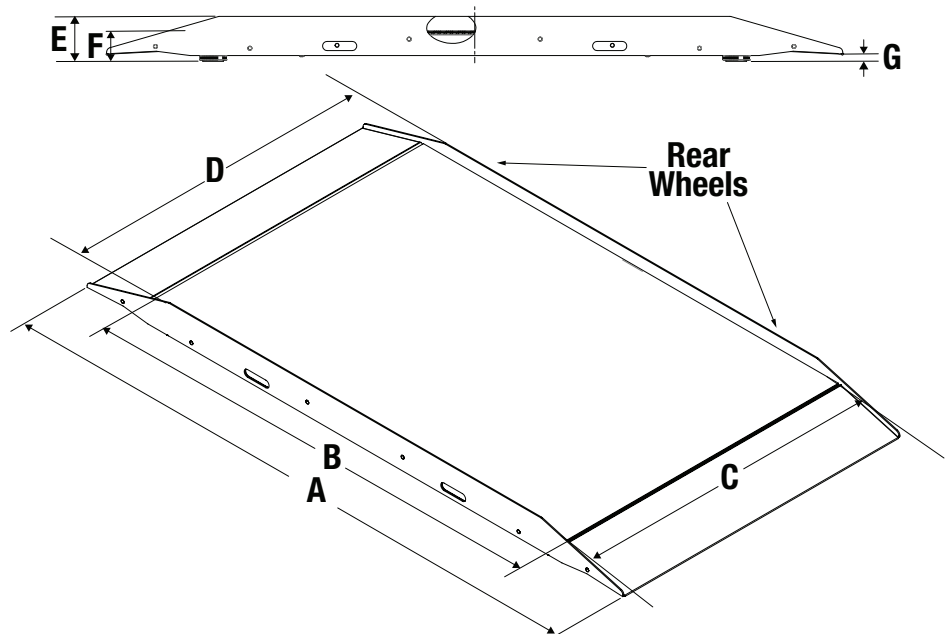

LARGE ANIMAL  
SCALES

# RoughDeck® SLV

Single Animal Livestock Scale



## Standard Features

- Mild steel construction
- Rugged diamond safety treadplate deck
- Rigid structural steel channel frame
- NEMA Type 4X stainless steel side-access junction box without quick connector
- Signal trim summing board
- Four adjustable stainless steel SUREFOOT™ support feet
- SURVIVOR® EL147HE hostile environment load cell cable
- Four alloy steel load cells

## Specifications

**Full Scale Capacity:**  
4,000 lb, 1 lb increments

**End Load Capacity:**  
125% full scale

**Cable Length:**  
20 ft (6 m)

**Warranty:**  
Two-year limited (scale only)

**Approvals:**  
NTEP 92-001 Class III 4,000d

*Capacity not to exceed 4,000 lb x 1 lb and platform size not to exceed 32 sq ft*

Approvals



## Part Number/Price

Part #	Capacity	Outside Dimensions	Est. Weight	Price
103617	4,000 lb, 20 ft without Quick Connect, modified to fit gate and rack (scale platform only)	8 × 3 ft	565 lb	\$3,500.00
78452	4,000 lb, 20 ft without Quick Connect (gate and rack not included) (scale platform only)	8 × 3 ft	565 lb	\$3,500.00
103619	4,000 lb, 20 ft without Quick Connect, modified to fit gate and rack (scale platform only)	8 × 4 ft	750 lb	\$3,600.00
78453	4,000 lb, 20 ft without Quick Connect (gate and rack not included) (scale platform only)	8 × 4 ft	750 lb	\$3,600.00
<b>RoughDeck SLV 4,000 lb Bundle Package (Ships Assembled)</b>				
226205	Scale Pkg, 3 × 8 ft scale, 4,000 lb capacity with racks, swing gates and kick plates, 380 Synergy indicator, factory calibrated prior to shipping with 1 lb increments	8 × 3 ft	1,200 lb	\$6,500.00
226206	Scale Pkg, 3 × 8 ft scale, 4,000 lb capacity with sliding gate, deck, racks, gates, and kick plates, 380 Synergy indicator, factory calibrated prior to shipping with 1 lb increments	8 × 3 ft	1,310 lb	\$9,200.00
226207	Scale Pkg, 4 × 8 ft scale, 4,000 lb capacity with racks, swing gates and kick plates, 380 Synergy indicator, calibrated prior to shipping with 1 lb increments	8 × 4 ft	1,500 lb	\$7,100.00
226209	Scale Pkg, 4 × 8 ft scale, 4,000 lb capacity with sliding gate, deck, racks, gates and kick plates, 380 Synergy factory calibrated prior to shipping with 1 lb increments	8 × 4 ft	1,610 lb	\$9,800.00

## Options/Accessories

Part #	Description	Price
Consult	Smooth deck instead of diamond safety tread plate	N/C
Consult	Stainless steel load cells (RL32018S IP66) and hardware	\$120.00 list price add-on
Consult	Stainless steel hermetically sealed load cells (RL32218S-HE IP69K) and hardware	\$440.00 list price add-on
Consult	Angle iron bolted to scale for wood deck provisions (wood to be supplied by customer)	\$225.00
Consult	Rubber mat	Consult
226036	380 universal segmented LCD display, battery powered, Synergy Series with 4-pin quick connect ag scale cable	\$765.00
18777	Floor anchor plates, mild steel (set of 2)	\$38.00
18778	Floor anchor plates, stainless steel (set of 2)	\$50.00

LARGE ANIMAL  
SCALES

# RoughDeck® SLV

Single Animal Livestock Scale

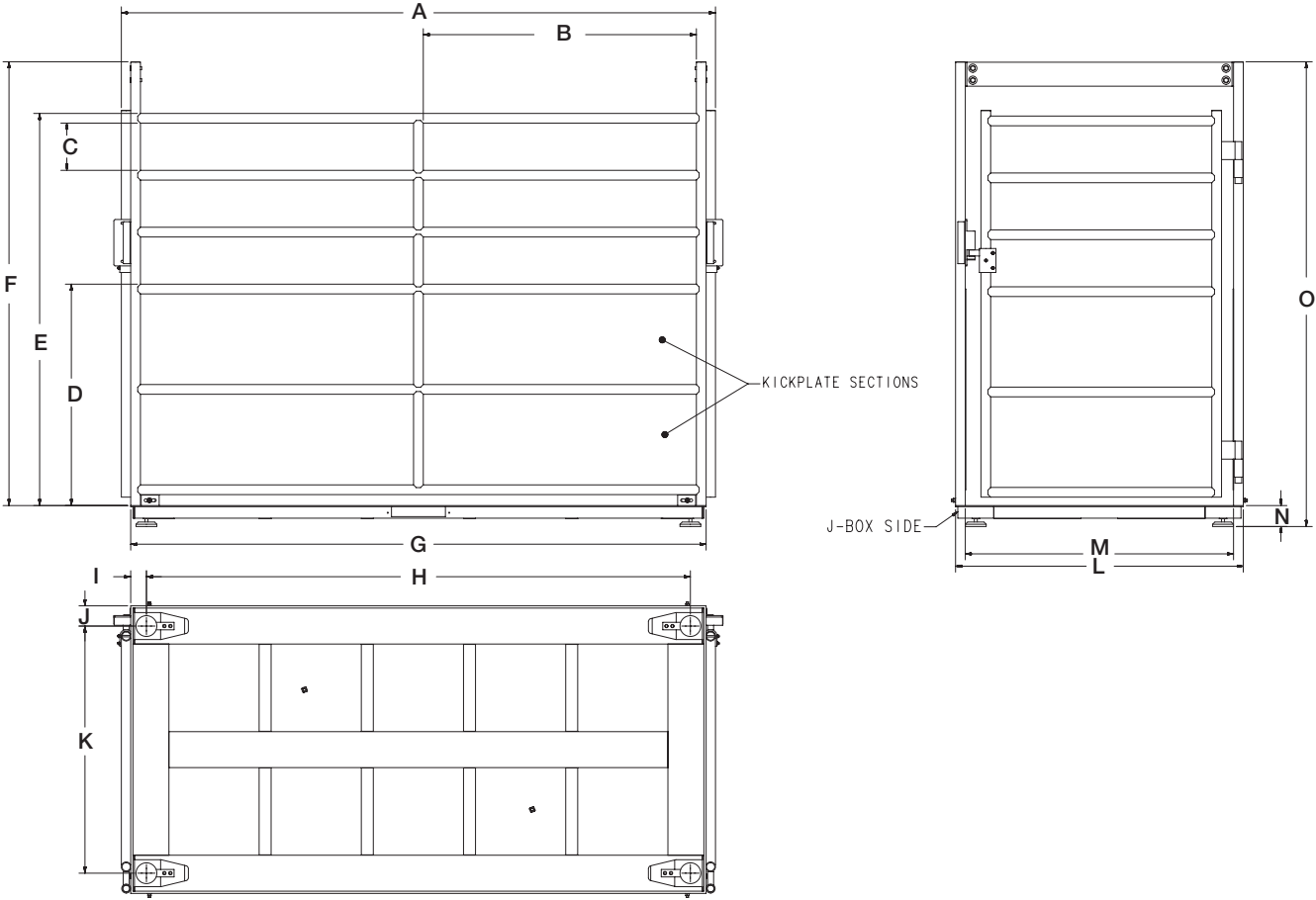

LARGE ANIMAL SCALES

### Dimensions

RoughDeck SLV			
3 × 8 ft			
A	99.12 in	I	2.63 in
B	45.56 in	J	3.38 in
C	7.88 in	K	29.25 in
D	36.95 in	L	36.00 in
E	65.45 in	M	32.75 in
F	74.00 in	N	3.50 in
G	95.00 in	O	77.58 in
H	90.75 in		
4 × 8 ft			
A	99.12 in	I	2.63 in
B	45.56 in	J	3.38 in
C	7.88 in	K	41.25 in
D	36.95 in	L	48.00 in
E	65.45 in	M	44.75 in
F	74.00 in	N	3.50 in
G	95.00 in	O	77.58 in
H	90.75 in		

# RoughDeck® EQ

Equine Floor Scale and Indicator Package



## Standard Features

- Package includes 4 ft × 6 ft × 4.25 in floor scale with stall mat, 20 ft of SURVIVOR EL147HE hostile environment load cell cable and indicator
- Mat thickness 0.75 in

### Scale

- Heavy-duty design with structural steel channel frame
- Stall mat to reduce noise and instill equine comfort
- Four adjustable stainless steel SUREFOOT™ support feet
- Powder-coated black matte finish

### Indicator

- LCD backlit display for a variety of environments
- Battery backed time and date
- Communication ports for connecting to a variety of peripherals

## RoughDeck EQ Specifications

### End Load Capacity:

100% full scale at 2,500 lb

### Load Cells:

Model RL32018 alloy steel environmentally sealed IP66

### Junction Box:

Side access, TuffSeal JB4SS stainless steel, NEMA Type 4X with a signal card

### Feet:

Stainless steel SUREFOOT, adjustable (+0.25 in or -0.125 in) for leveling the scale

### Finish:

Powder coat painted, black matte

### Cable Length:

20 ft (6.1 m) for connecting scale junction box to indicator

### Threaded Eyebolt:

One lifting hole located in center of scale for easy install (requires 1/2-20NF eyebolt, not included)

### Warranty:

Two-year limited

## 482 Specifications

### Power:

Line voltages: 100 to 240 VAC  
Frequency: 50/60 Hz  
DC voltages: n/a

### Communication Ports:

Com 1: RS-232 full duplex  
Com 2: RS-232 full duplex or 20 mA simplex, continuous  
Both ports 1200, 2400, 4800, 9600, 19200, 38400 baud seven or eight data bits, even, odd or no parity

### Optional Ethernet and USB Board:

USB five-pin header for PC, printer or flash drive  
Ethernet TCP/IP, RJ45 jack, server and client ports

### Display:

LCD backlit, transmissive/ transfective, 0.8 in (20 mm), six-digit, seven-segment

### Annunciators:

Gross, net, center of zero, standstill, lb, kg, tare, preset tare

### Keys/Buttons:

Flat membrane panel, embossed keys, tactile feel

### Rating/Material:

NEMA Type 4X/IP66  
Stainless steel

### Approvals:

NTEP 12-123  
Measurement Canada AM-5892C  
CE  
cULus

## Part Number/Price

Part #	Size (W × L × H)	Capacity	Est. Weight	Price
<b>RoughDeck EQ Floor Scale with 482 Indicator</b>				
<b>207811</b>	4 ft × 6 ft × 4.25 in	2,500 × 0.5 lb	610 lb	\$3,670.00

Note: Height includes stall mat

## Options/Accessories

Part #	Description	Price
<b>Consult</b>	Access ramps	+ Consult list price add-on
<b>Consult</b>	Smooth deck instead of diamond safety tread plate	N/C
<b>12839*</b>	50 lb cast iron calibration weights	\$160.00
<b>207812</b>	Guide rail, 5.66 ft long × 4.36 ft high, field installable, black matte finish	+\$295.00 list price add-on
<b>18777</b>	Floor anchor plates	\$38.00
<b>Consult</b>	Hermetically sealed load cells	Consult

\*Quantity of 5 weights is recommended for 10% of capacity.



RoughDeck EQ with two optional guide rails installed



# RoughDeck® EQ

Equine Floor Scale and Indicator Package

## Dimensions

### 4 ft × 6 ft × 4.25 in with No Optional Guide Rail

A	48.00 in	D	66.76 in
B	72.00 in	E	41.25 in
C	4.25 in		

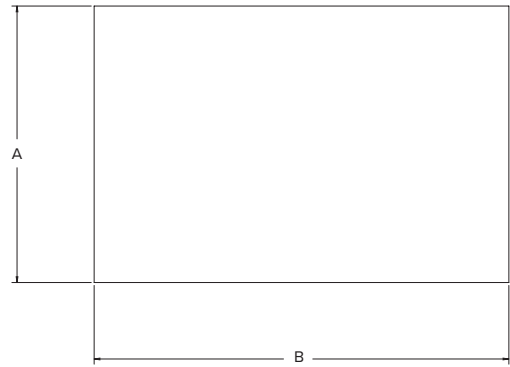
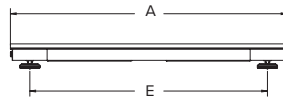
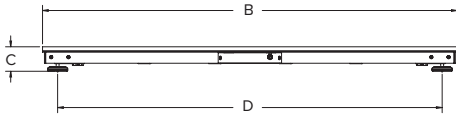

## Dimensions

### 4 ft × 6 ft × 4.25 in with One Optional Guide Rail

A	50.25 in	F	4.25 in
B	48.00 in	G	66.76 in
C	72.00 in	H	48.00 in
D	67.90 in	I	41.25 in
E	52.26 in		

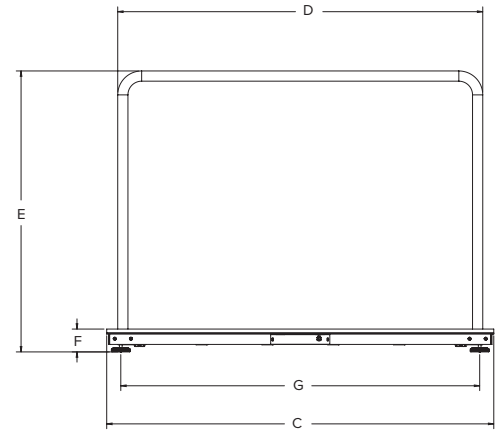
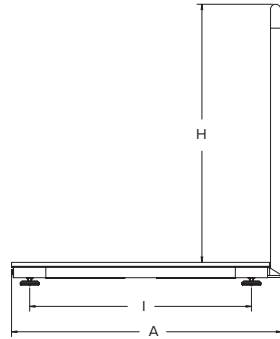
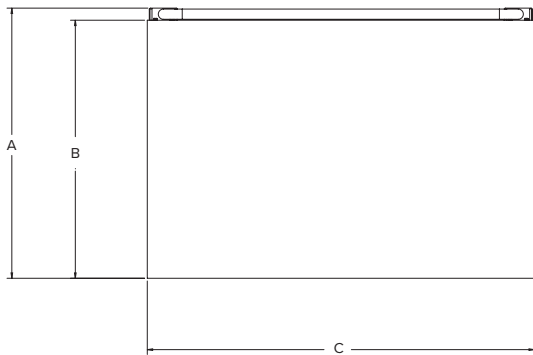

## Dimensions

### 4 ft × 6 ft × 4.25 in with Two Optional Guide Rails

A	50.25 in	F	4.25 in
B	48.00 in	G	66.76 in
C	72.00 in	H	48.00 in
D	67.90 in	I	52.15 in
E	52.26 in	J	41.25 in

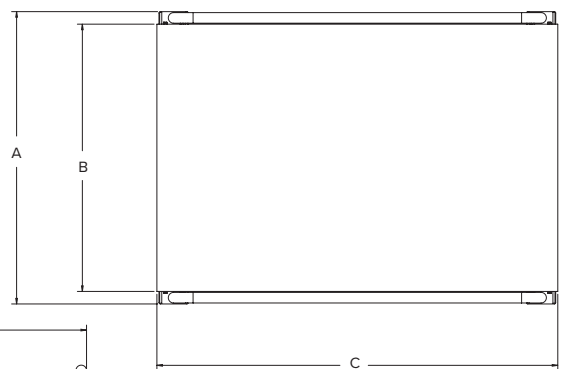
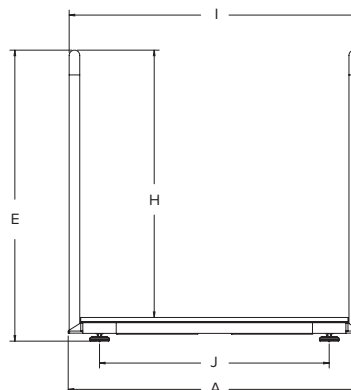
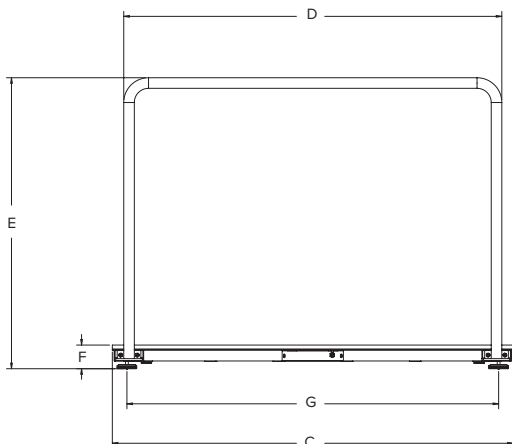

LARGE ANIMAL  
SCALES