

S-BEAMS

Page 204

UB1, STAINLESS STEEL

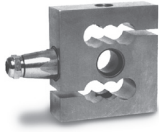

Designed for single or multiple-cell tension load applications, these stainless steel S-beams feature voltage factory calibration, assuring matched outputs for easy calibration in multiple-cell applications. Features hermetic sealing of the strain gauge area and cable entry, providing the ultimate in protection from outside elements. 20 ft of cable is included to simplify cable and load cell repairs. Capacities range from 10 kN to 50 kN.



Page 205

UB6, STAINLESS STEEL



Stainless steel S-beam designed to meet the most stringent accuracy requirements. 20 ft of field-replaceable cable is included to simplify cable and load cell repairs. Capacities range from 1 kN to 5 kN.



SINGLE-ENDED BEAMS

Page 206

SLB, STAINLESS STEEL



This stainless steel, single-ended beam has one of the highest NTEP Certified ratings in the industry. A new generation of potting makes this load cell suitable for tough industrial environments. Capacities range from 200 lb to 5,000 lb. Complete with 10 ft of load cell cable.



Page 207

SB4, STAINLESS STEEL



Designed for multiple-cell applications, such as floor scales and hoppers, these stainless steel, single-ended beams are used exclusively in Rice Lake Weighing Systems' Paramounts® HS mounting systems. mV/V/ohm calibration assures matched outputs for easy calibration. Features true hermetic sealing of both the strain gauge area and cable entry, providing protection from outside elements. Includes field-replaceable load cell cable to simplify cable and load cell repairs. Available in both NTEP Certified and Non-NTEP Certified ranges 5 kN to 100 kN.



Page 208

SB5, STAINLESS STEEL



Made for multiple-cell applications, such as floor scales and tank, bin and hopper weighing systems. Used exclusively in Rice Lake Weighing Systems' Paramounts® EP mounting systems. mV/V/ohm calibration assures matched outputs for easy calibration. Available in both NTEP Certified and Non-NTEP Certified ranges 5 kN to 100 kN.



Page 209

BK2, STAINLESS STEEL



Designed to lower the scale profile by providing a load cell that is half the overall height of traditional solutions. Ideal for applications such as low-profile floor scales, this model is constructed of stainless steel and is environmentally protected for indoor applications. mV/V/ohm calibration assures matched outputs for easy calibration. Available in capacities from 200 kg to 2,000 kg and includes 10 ft of standard load cell cable.



Page 210

SB6, STAINLESS STEEL



Stainless steel, hermetically sealed single-ended beam with special loading hole provides excellent performance in the harshest environments with a low-profile design. Capacities range from 0.2 kN to 2 kN. Complete with 10 ft of load cell cable.



SINGLE-ENDED BEAMS

Page 211

SB14, STAINLESS STEEL



Stainless steel, fully hermetically sealed, single-ended beam suitable for the harshest environments. Capacities range from 500 lb to 5,000 lb. Complete with 10 ft of load cell cable.



ROCKER COLUMNS

Page 212

RC1, STAINLESS STEEL



Offers stainless steel and hermetic sealing, making these cells suitable for use in tough industrial environments. Capacities are 25 t, 40 t and 50,000 lb. Cable lengths of 15 ft, 35 ft and 60 ft for easy field replacement and load cell repairs.



Page 213

RC3, STAINLESS STEEL



Rocker designed and provides superior performance and full hermetic design in applications in moist and high humidity environments. Constructed of stainless steel. Available in capacities from 7.5 t to 50 t.



SINGLE POINTS

Page 214

PCB, STAINLESS STEEL



A unique "brick" style of load cell. Constructed of stainless steel and hermetically sealed, this unique design provides superior protection in applications where moisture and high humidity are problems. This model features both a welded gauge cavity area, and waterproof cable entry for long-lasting performance. Provides an upgrade from aluminum to stainless steel. Available in capacities from 50 kg to 1,000 kg. Each unit includes 10 ft of load cell cable.



Page 215

PC1, STAINLESS STEEL



With an environmentally protected seal and stainless steel construction, these load cells are suitable for use in tough industrial environments. Capacities range from 10 kg to 200 kg.



SINGLE POINTS

Page 216

PC3, STAINLESS STEEL



A stainless steel, single point load cell. Has an IP67 rating and is environmentally sealed, making it ideal for harsh environments. Capacities range from 7 kg to 150 kg. Complete with 10 ft of load cell cable.



Page 217

PC4, STAINLESS STEEL



Hermetic load cell that is ideal for adverse conditions. Made of stainless steel with a single point design. NTEP Certified and OIML approved capacities range from 10 kg to 100 kg. Complete with 10 ft of cable.



Page 218

PC6, STAINLESS STEEL

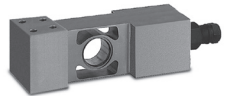

Constructed of stainless steel utilizing hermetic sealing, these load cells are suitable for tough industrial environments. Includes 3 m of field-replaceable load cell cable to simplify cable and load cell repairs. Capacities range from 20 kg to 200 kg.



Page 232193

PC7, STAINLESS STEEL



Ideal for washdown applications. Hermetically sealed to IP69K standards, this stainless steel component comes with 3 m of cable and an integrated mounting spacer for easy installation. Available in capacities ranging from 100 kg to 500 kg.



Page 220

PC2, STAINLESS STEEL



This high-accuracy stainless steel, single-point load cell is an ideal replacement cell for hopper applications with damaged bellows. This cell also features complete hermetic sealing for use in the toughest environments. This product is offered at 150 kg and comes complete with 10 ft of load cell cable.



PLANAR BEAM

Page 221

PB, ALUMINUM



An inexpensive alternative planar beam used in low profile, light capacity applications. The compact size and mV/V per ohm calibration simplifies installation. Capacities range from 15 kg to 150 kg and includes 1.5 m of load cell cable.

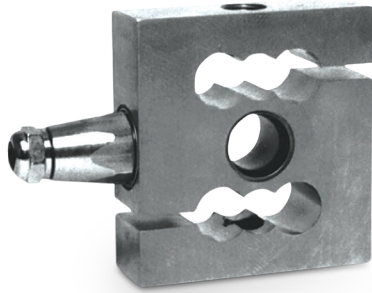

Picture is a representation of actual product.

Approvals

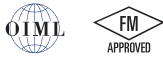

Order Information

Load Rating	Part #	Est. Weight	Price
10 kN	17073	4 lb	\$747.00
20 kN	17074	4 lb	\$747.00
50 kN	17075	13 lb	\$747.00
Options			
Conduit adapter, 1/2-14 NPT	17703	1 lb	\$50.00

Dimensions

Rated Capacity	A*	B	D	E
kN/in				
10 to 20	5/8-18 UNF	1.18	3.38	3.62
50	1-12 UNF	1.69	5.62	5.37

*Also available with metric threads

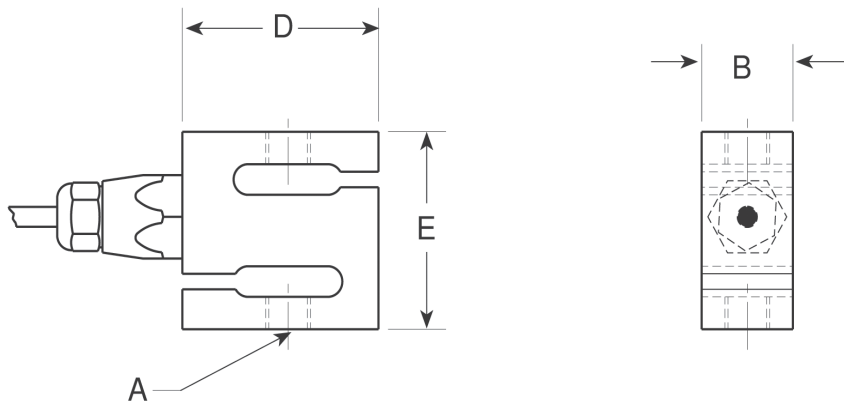

Specifications

- Full Scale Output:**
2.0 mV/V
mV/V/ohm calibration
- Output Resistance:**
1,000 (± 2) ohm
- Input Resistance:**
1,100 (± 50) ohm
- Material/Finish:**
Stainless steel
- Temperature:**
Operating:
0 °F to 150 °F (-18 °C to 65 °C)
- Seal Type:**
Hermetically sealed, IP69K
- Safe Overload:**
200% full scale
- Rated Excitation:**
5 to 15 VDC
- Nonlinearity:**
0 to -0.03% full scale
- Hysteresis:**
0 to +0.05% full scale
- Combined Error:**
± 0.03%
- Insulation Resistance:**
10,000 megohm
- Cable Length:**
20 ft
- Cable Diameter:**
0.196 in
Polyurethane jacket
- Cable Color Code:**
Green +Excitation
Black -Excitation
White +Signal
Red -Signal
Yellow Shield
- Warranty:**
One-year limited
- Approvals:**
FM
OIML

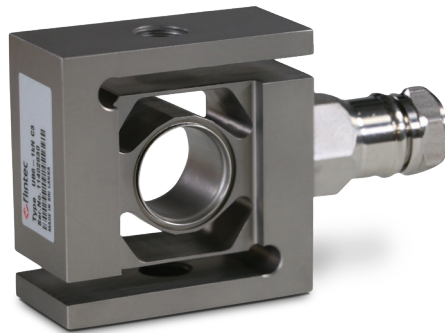

Picture is a representation of actual product.

Approvals

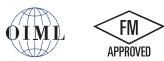

Order Information

Load Rating	Part #	Est. Weight	Price
1 kN	36214	3lb	\$640.00
2 kN	36215	3lb	\$640.00
5 kN	36216	3lb	\$640.00

Dimensions

Rated Capacity	A*	B	D	E
kN/in				
1 to 5	1/2-20 UNF	1.20	2.42	2.42

*Also available with metric threads

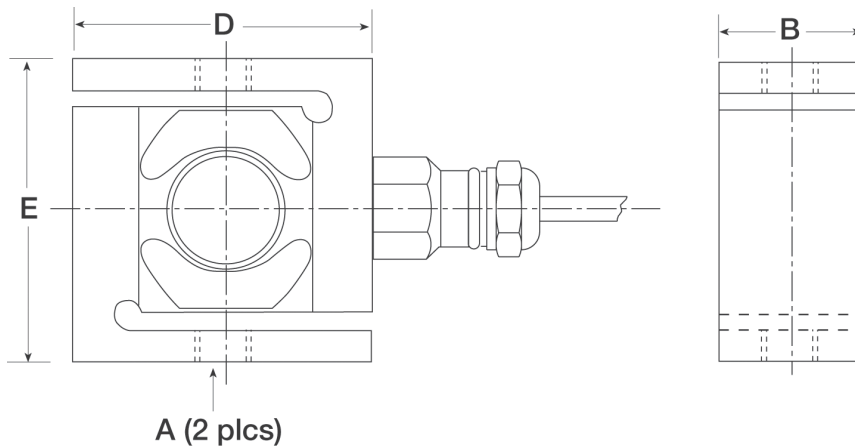

Specifications

- Full Scale Output:**
2.0 mV/V
mV/V/ohm calibration
- Output Resistance:**
1,000 (± 2) ohm
- Input Resistance:**
1,100 (± 50) ohm
- Material/Finish:**
Stainless steel
- Temperature:**
Operating:
0 °F to 150 °F (-18 °C to 65 °C)
- Seal Type:**
Hermetically sealed, IP69K
- Safe Overload:**
200% full scale
- Rated Excitation:**
5 to 15 VDC
- Combined Error:**
0.02% full scale
- Insulation Resistance:**
5,000 megohm
- Cable Length:**
20 ft
- Cable Diameter:**
0.196 in
Polyurethane jacket
- Cable Color Code:**
Green +Excitation
Black -Excitation
White +Signal
Red -Signal
Yellow Shield
- Warranty:**
One-year limited
- Approvals:**
FM
OIML



SLB

Stainless Steel, Environmentally Sealed, NTEP Certified 1:4,000 Class III Single Cell/1:7,500 Class III Multiple Cell, OIML C3, IP67



Picture is a representation of actual product.

Approvals



Order Information: Blind Hole

Load Rating	Part#	Est. Weight	Price
200 lb	77422	3 lb	\$350.00
500 lb	77423	3 lb	\$350.00
1,000 lb	68527	3 lb	\$350.00
2,500 lb	68528	3 lb	\$350.00
5,000 lb	68529	3 lb	\$350.00

Dimensions

Rated Capacity	D	F	G	H	I	P	S
200 to 5,000 lb/in	0.51	5.37	0.50	1.00	3.00	2.42	1.19

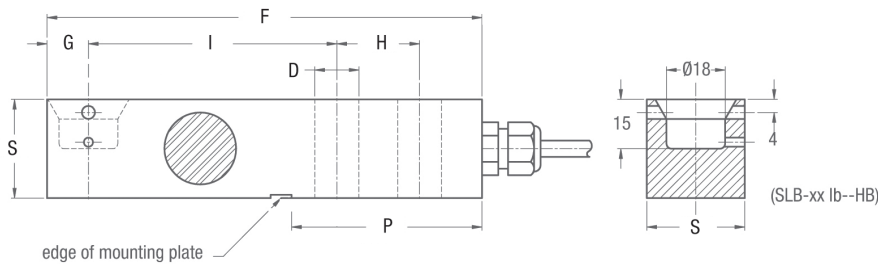

Interchangeable Products

FAIRBANKS®*
LCF-HR4050-3

*Stainless overbraid cable

Specifications

Full Scale Output:

2.0 mV/V
mV/V/ohm calibration

Output Resistance:

1,000 (± 2) ohm

Input Resistance:

1,100 (± 50) ohm

Material/Finish:

Stainless steel

Temperature:

Compensated:
14 °F to 104 °F (-10 °C to 40 °C)
Operating:
0 °F to 150 °F (-18 °C to 65 °C)

Seal Type:

Environmentally sealed, IP67

Combined Error:

0.01% full scale

Safe Overload:

200% full scale

Safe Sideload:

100% full scale

Rated Excitation:

5 to 15 VDC

Insulation Resistance:

5,000 megohm

Cable Length:

10 ft

Cable Diameter:

0.196 in
Polyurethane jacket

Cable Color Code:

Green +Excitation
Black -Excitation
White +Signal
Red -Signal
Yellow Shield

Warranty:

One-year limited

Approvals:

FM
NTEP
OIML



Picture is a representation of actual product.

Approvals



Order Information

Load Rating	Part #	Est. Weight	Price
NTEP Certified/OIML			
5 kN	26662	4 lb	\$715.00
10 kN	26663	4 lb	\$715.00
23 kN	26664	4 lb	\$715.00
50 kN	26665	7 lb	\$795.00
Non-NTEP Certified/Non-OIML			
5 kN	17390	4 lb	\$652.00
10 kN	17391	4 lb	\$652.00
23 kN	17392	4 lb	\$652.00
50 kN	17393	7 lb	\$715.00
100 kN	17394	17 lb	\$970.00
Options			
Conduit adapter, 1/2-14 NPT	17703	1 lb	\$50.00

30 ft Cables

Load Rating	Part #	Est. Weight	Price
NTEP Certified/OIML			
5 kN	100164	4 lb	\$821.00
10 kN	100165	4 lb	\$821.00
23 kN	100166	4 lb	\$821.00
50 kN	100167	7 lb	\$970.00
Non-NTEP Certified/Non-OIML			
5 kN	100169	4 lb	\$747.00
10 kN	100170	4 lb	\$747.00
23 kN	100171	4 lb	\$747.00
50 kN	100173	7 lb	\$832.00
100 kN	100168	17 lb	\$1,033.00

Dimensions

Rated Capacity kN/in	C	C1	H	H1	H2	H3	H5	L	L1	L2	L3	L4	W
5 to 23	0.53	0.71	1.42	0.39	0.59	1.19	0.16	6.10	0.59	1.38	3.15	2.98	1.18
50	0.85	0.98	1.93	0.58	0.81	1.62	0.31	7.48	0.83	1.57	4.13	3.66	1.69
100	1.06	1.18	2.87	0.82	1.21	2.43	—	9.65	1.19	1.97	5.31	4.72	2.36

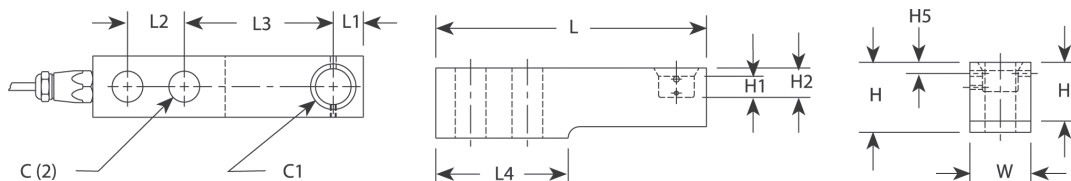

Weigh Module Available

- RICE LAKE WEIGHING SYSTEMS
Paramounts® HE..... page 36
- RICE LAKE WEIGHING SYSTEMS
Paramounts® HS..... page 49

Specifications

- Full Scale Output:**
2.0 mV/V
mV/V/ohm calibration
- Output Resistance:**
1,000 (± 2) ohm
- Input Resistance:**
1,100 (± 50) ohm
- Material/Finish:**
Stainless steel
- Temperature:**
Compensated:
14 °F to 104 °F (-10 °C to 40 °C)
Operating:
0 °F to 150 °F (-18 °C to 65 °C)
- Seal Type:**
Hermetically sealed, IP69K
- Safe Overload:**
200% full scale
- Safe Sideload:**
100% full scale
- Rated Excitation:**
5 to 15 VDC
- Combined Error:**
± 0.03% full scale
- Insulation Resistance:**
10,000 megohm
- Deflection at Capacity:**
10 kN: 0.012 in
23 kN: 0.02 in
50 kN: 0.012 in
100 kN: 0.016 in
- Cable Length:**
5 to 23 kN: 10 ft
50 to 100 kN: 15 ft
Also available in 30 ft
- Cable Diameter:**
0.196 in
Polyurethane jacket
- Cable Color Code:**
Green +Excitation
Black -Excitation
White +Signal
Red -Signal
Yellow Shield
- Warranty:**
One-year limited
- Approvals:**
FM
NTEP
OIML

FLINTEC®

SB5

Stainless Steel, Environmentally Sealed, NTEP Certified 1:5,000 Class III Multiple Cell, OIML C3, IP67



Picture is a representation of actual product

Approvals



Order Information

Load Rating	Part #	Est. Weight	Price
NTEP Certified/OIML			
5 kN	33387	3 lb	\$430.00
10 kN	33388	3 lb	\$430.00
20 kN	33389	3 lb	\$430.00
50 kN	33390	7 lb	\$560.00
Non-NTEP Certified/Non-OIML			
100 kN	33391	16 lb	\$853.00

30 ft Cables

Load Rating	Part #	Est. Weight	Price
NTEP Certified/OIML			
5 kN	100174	5 lb	\$487.00
10 kN	100175	5 lb	\$487.00
20 kN	100176	5 lb	\$487.00
50 kN	100177	7 lb	\$720.00
Non-NTEP Certified/Non-OIML			
100 kN	100178	16 lb	\$932.00

Dimensions

Rated Capacity	C	C1	H	H1	H2	H3	H5	L	L1	L2	L3	L4	W
kN/in													
5 to 20	0.53	0.71	1.42	0.39	0.59	1.19	0.16	6.10	0.59	1.38	3.15	2.98	1.18
50	0.85	0.98	1.93	0.58	0.81	1.62	0.31	7.48	0.83	1.57	4.13	3.66	1.69
100	1.06	1.18	2.87	0.82	1.21	2.43	—	9.65	1.19	1.97	5.31	4.72	2.36

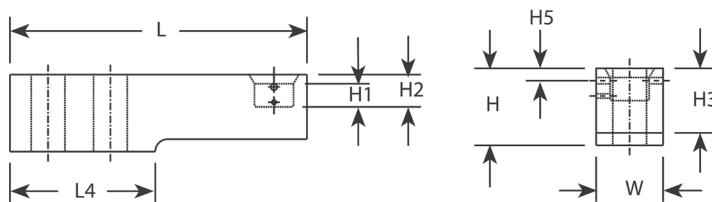
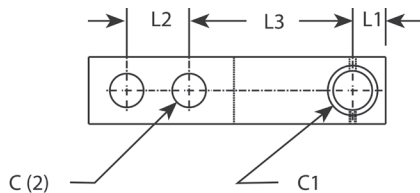

Weigh Module Available

RICE LAKE WEIGHING SYSTEMS
Paramounts® EPpage 47

Specifications

- Full Scale Output:**
2.0 mV/V
mV/V/ohm calibration
- Output Resistance:**
1,000 (± 2) ohm
- Input Resistance:**
1,100 (± 50) ohm
- Material/Finish:**
Stainless steel
- Temperature:**
Compensated:
14 °F to 104 °F (-10 °C to 40 °C)
Operating:
0 °F to 150 °F (-18 °C to 65 °C)
- Seal Type:**
Environmentally sealed, IP67
- Safe Overload:**
200% full scale
- Safe Sideload:**
100% full scale
- Rated Excitation:**
5 to 15 VDC
- Combined Error:**
± 0.03% full scale
- Insulation Resistance:**
10,000 megohm
- Deflection at Capacity:**
5 kN: 0.008 in
10 kN: 0.012 in
20 kN: 0.02 in
50 kN: 0.012 in
- Cable Length:**
5 to 20 kN: 10 ft
50 to 100 kN: 15 ft
Also available in 30 ft
- Cable Diameter:**
0.196 in
Polyurethane jacket
- Cable Color Code:**
Green +Excitation
Black -Excitation
White +Signal
Red -Signal
Yellow Shield
- Warranty:**
One-year limited
- Approvals:**
FM
NTEP
OIML



Picture is a representation of actual product.

Approvals



Available upon request

Available upon request

Order Information

Load Rating	Part #	Est. Weight	Price
NTEP Certified			
500 kg	84839	2 lb	\$243.00
1,000 kg	84840	2 lb	\$243.00
2,000 kg	84841	2 lb	\$243.00
Non-NTEP Certified			
200 kg	84838	2 lb	\$243.00

Dimensions

Rated Capacity	A	B	C	D	E	F	G	H	T*
kg/mm									
200	128.5	12.7	76.2	25.4	53.8	13(2x)	31.8	16.1	1/2-20 UNF
500	128.5	12.7	76.2	25.4	53.8	13(2x)	31.8	16.1	1/2-20 UNF
1,000	128.5	12.7	76.2	25.4	53.8	13(2x)	31.8	19.1	1/2-20 UNF
2,000	130.2	12.7	76.2	25.4	53.8	13(2x)	31.8	25.4	1/2-20 UNF

*Metric thread is available

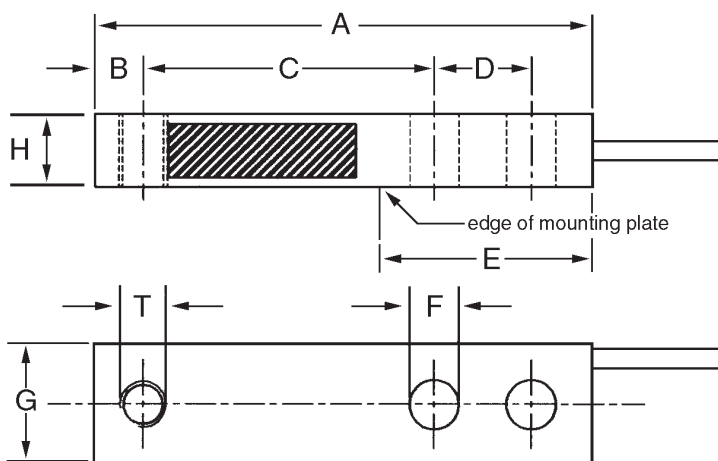

Specifications

Full Scale Output:

2.0 mV/V
mV/V/ohm calibration

Output Resistance:

1,000 (± 2) ohm

Input Resistance:

1,100 (± 50) ohm

Material/Finish:

Stainless steel

Temperature:

Compensated:
14 °F to 104 °F (-10 °C to 40 °C)
Operating:
0 °F to 150 °F (-18 °C to 65 °C)

Seal Type:

Environmentally sealed, IP67

Safe Overload:

200% full scale

Safe Sideload:

100% full scale

Rated Excitation:

5 to 15 VDC

Combined Error:

0.030%

Insulation Resistance:

5,000 megohm

Cable Length:

10 ft
Also available in 30 ft

Cable Diameter:

0.196 in
Polyurethane jacket

Cable Color Code:

Green +Excitation
Black -Excitation
White +Signal
Red -Signal
Yellow Shield

Warranty:

One-year limited

Approvals:

NTEP
EX (Available upon request)
OIML (Available upon request)

SB6

Stainless Steel, Hermetically Sealed, OIML C3, IP68

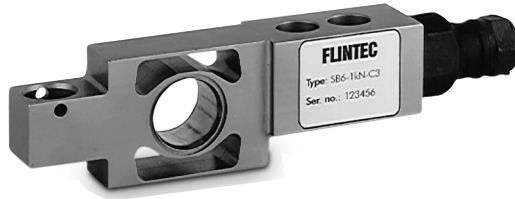

Picture is a representation of actual product.

Approvals

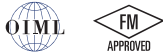

Order Information

Load Rating	Part #	Est. Weight	Price
0.2 kN	41163	3 lb	\$556.00
0.5 kN	41164	3 lb	\$556.00
1 kN	41165	3 lb	\$556.00
2 kN	41166	3 lb	\$556.00

Dimensions

Rated Capacity	A	B	C	D	E	F	G	H	I	J
kN/mm										
0.2 to 2	130.0	82.0	18.0	20.0	30.0	8.7	16.0	8.7	22.0	30.0

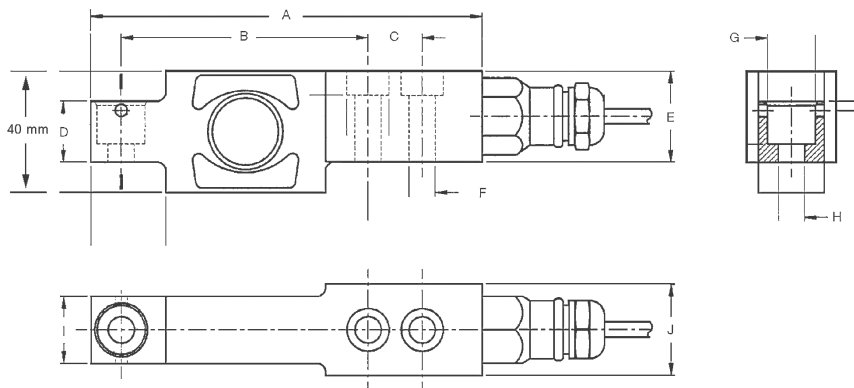

Specifications

- Full Scale Output:**
2.0 mV/V
mV/V/ohm calibration
- Output Resistance:**
1,000 (± 2) ohm
- Input Resistance:**
1,100 (± 50) ohm
- Material/Finish:**
Stainless steel
- Temperature:**
Operating:
0 °F to 150 °F (-18 °C to 65 °C)
- Seal Type:**
Hermetically sealed, IP68
- Safe Overload:**
200% full scale
- Safe Sideload:**
100% full scale
- Rated Excitation:**
5 to 15 VDC
- Combined Error:**
0.01% full scale
- Insulation Resistance:**
5,000 megohm
- Cable Length:**
10 ft
- Cable Diameter:**
0.196 in
Polyurethane jacket
- Cable Color Code:**
Green +Excitation
Black -Excitation
White +Signal
Red -Signal
Yellow Shield
- Warranty:**
One-year limited
- Approvals:**
FM
OIML



Picture is a representation of actual product.

Approvals



Available upon request

Order Information-CU Version*

Load Rating	Part#	Est. Weight	Price
500 lb	41167	3 lb	\$493.00
1,000 lb	41168	3 lb	\$493.00
2,500 lb	41169	3 lb	\$493.00
5,000 lb	41170	3 lb	\$493.00

*CU versions have a counterbore/unified thread 1/2-20UNF

Order Information-HB Version**

Load Rating	Part#	Est. Weight	Price
500 lb	119556	3 lb	\$493.00
1,000 lb	119557	3 lb	\$493.00
2,500 lb	119558	3 lb	\$493.00
5,000 lb	119559	3 lb	\$493.00

**HB versions have a blind load hole

Dimensions

Rated Capacity	A	B	C	D	E	F	G	H	I	J
lb/in										
500 to 5,000	5.25	3.00	1.00	0.50	1.18	2.35	1.61	0.59	1/2-20 UNF	1.22

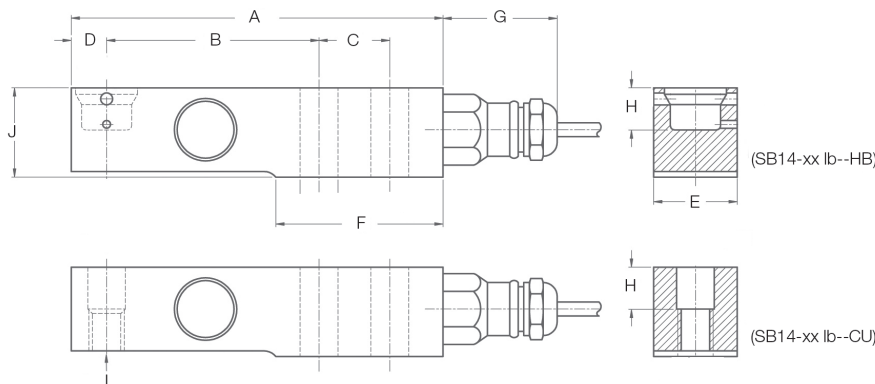

Interchangeable Products

FAIRBANKS®
LCF-HR4060-XX

Specifications

Full Scale Output:

2.0 mV/V
mV/V/ohm calibration

Output Resistance:

1,000 (± 2) ohm

Input Resistance:

1,100 (± 50) ohm

Material/Finish:

Stainless steel

Temperature:

Compensated:
14 °F to 104 °F (-10 °C to 40 °C)

Operating:
0 °F to 150 °F (-18 °C to 65 °C)

Seal Type:

Hermetically sealed, IP69K

Safe Overload:

200% full scale

Safe Sideload:

100% full scale

Rated Excitation:

5 to 15 VDC

Combined Error:

± 0.03% full scale

Insulation Resistance:

5,000 megohm

Cable Length:

10 ft

Cable Diameter:

0.196 in
Polyurethane jacket

Cable Color Code:

Green +Excitation
Black -Excitation
White +Signal
Red -Signal
Yellow Shield

Warranty:

One-year limited

Approvals:

FM
NTEP
OIML (Available upon request)

RC1

Stainless Steel, Hermetically Sealed, NTEP Certified 1:10,000 Multiple Cell, OIML C3, IP68



Picture is a representation of actual product.

Approvals



Order Information

Load Rating	Part #	Est. Weight	Price
25 t (250 kN)*	36217	8 lb	\$858.00
40 t (400 kN)	36218	10 lb	\$1,457.00
50,000 lb**	170734	8 lb	\$1,075.00
Accessories			
Conduit adapter, 1/2-14 NPT	17703	1 lb	\$50.00
Load cup*, upper (25 t only)	71602	-	\$195.00
Load cup*, lower (25 t only)	44290	-	\$195.00
Anti-rotation pin	214044	-	\$10.00

*For Mettler Toledo® digital to analog conversion: requires replacement of all system load cells, junction box and instrumentation; consult factory. Kit on page 81.

**1,000ohm bridge

Dimensions

Rated Capacity	H1	H2	L	R	W	W1
t/in						
25	7.56	1.22	2.44	10.98	2.83	1.46
40	8.86	1.34	2.72	14.02	3.35	1.46
50,000 lb	7.56	1.22	2.44	10.98	2.83	1.46

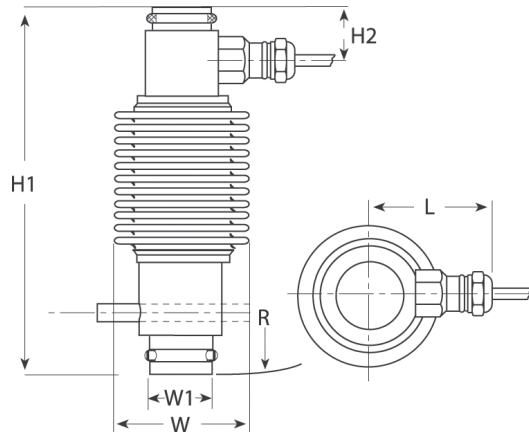

Interchangeable Products

- FAIRBANKS®
63215 LCF-HR4020-1
- FAIRBANKS®
82052

Specifications

- Full Scale Output:**
2.0 mV/V
mV/V/ohm calibration
- Output Resistance:**
351 (± 1) ohm
50,000 lb: 1,000 (± 2) ohm
- Input Resistance:**
400 (± 15) ohm
50,000 lb: 1,100 (± 50) ohm
- Material/Finish:**
Stainless steel
- Temperature:**
Compensated:
14 °F to 104 °F (-10 °C to 40 °C)
Operating:
0 °F to 150 °F (-18 °C to 65 °C)
- Seal Type:**
Hermetically sealed, IP68
- Safe Overload:**
200% full scale
- Safe Sideload:**
100% full scale
- Rated Excitation:**
5 to 15 VDC
- Combined Error:**
± 0.02% full scale
- Insulation Resistance:**
5,000 megohm
- Cable Length:**
25 t (250 kN): 35 ft
40 t (400 kN): 60 ft
50,000 lb: 15 ft overbraid
- Cable Diameter:**
0.196 in
Polyurethane jacket
- Cable Color Code:**
Green +Excitation
Black -Excitation
White +Signal
Red -Signal
Yellow Shield
- Warranty:**
One-year limited
- Approvals:**
FM
NTEP
OIML





Picture is a representation of actual product.

Approvals



Order Information

Load Rating	Part #	Est. Weight	Price
7.5 t	168944	3 lb	\$795.00
15 t	168946	3 lb	\$795.00
22.5 t	168947	3 lb	\$795.00
30 t	84203	7 lb	\$1,007.00
40 t	84204	9 lb	\$1,007.00
50 t	84205	10 lb	\$1,282.00
Options			
Upper cup (50 t) alloy steel	111365	5 lb	\$195.00
Lower cup (50 t) alloy steel	111366	5 lb	\$195.00
Upper cup (50 t) stainless steel	154107	5 lb	\$181.00
Lower cup (50 t) stainless steel	154106	5 lb	\$181.00

The kits for the RC3 cells are on page 82. Cups 111365 and 111366 are used in kits 129844 and 111367. Cups 154107 and 154106 are used in kits 154347, 154348 and 154349.

Dimensions

Rated Capacity	H1	H2	H3	H5	H7	H8	D1	D2
t/in								
7.5 to 22.5	3.50	1.73	0.67	0.43	1.10	2.95	1.10	2.56
30	5.51	2.76	1.20	0.51	1.55	3.31	1.55	3.19
40	5.91	2.95	1.22	0.51	1.55	3.31	1.55	3.19
50	7.01	3.50	1.26	0.67	1.73	3.71	1.73	3.90

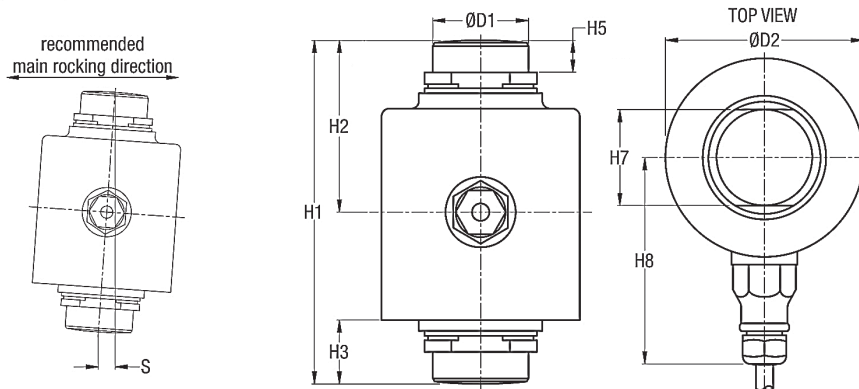

Interchangeable Products

FAIRBANKS®
30 t 70510 LCF-HR4020-2A

Specifications

Full Scale Output:

2.0 mV/V
mV/V/ohm calibration

Output Resistance:

1,000 (± 2) ohm

Input Resistance:

1,150 (± 50) ohm

Material/Finish:

Stainless steel

Temperature:

Compensated:
14 °F to 104 °F (-10 °C to 40 °C)
Operating:
0 °F to 150 °F (-18 °C to 65 °C)

Seal Type:

Hermetically sealed, IP69K

Safe Overload:

200% full scale

Safe Sideload:

200% full scale

Rated Excitation:

5 to 15 VDC

Combined Error:

0.02% full scale

Insulation Resistance:

5,000 megohm

Cable Length:

7.5 to 22.5 t: 40 ft
30 to 50 t: 18 m

Cable Diameter:

0.307 in
Polyurethane jacket

Cable Color Code:

Green +Excitation
Black -Excitation
White +Signal
Red -Signal
Yellow Shield

Warranty:

One-year limited

Approvals:

FM
NTEP
OIML

FLINTEC®

PCB

Stainless Steel, Hermetically Sealed, NTEP Certified 1:5,000 Class III Single Cell, OIML C3, IP69K

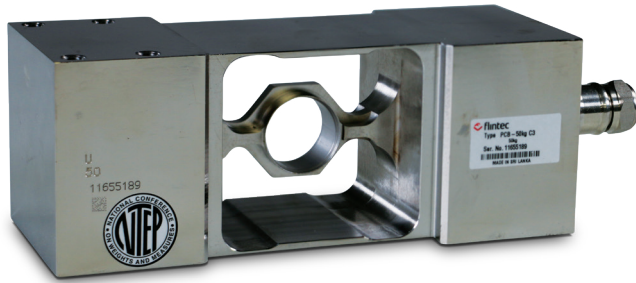

Picture is a representation of actual product.

Approvals



Order Information

Load Rating	Part #	Est. Weight	Price
50 kg	45274	15 lb	\$900.00
100 kg	45275	15 lb	\$900.00
250 kg	45276	15 lb	\$900.00
500 kg	45277	15 lb	\$900.00
1,000 kg	45278	15 lb	\$900.00
Options			
Conduit adapter, 1/2-14 NPT	17703	1 lb	\$50.00

Dimensions

Rated Capacity	L	L1	L2	W	W1	H
kg/mm						
50 to 1,000	190.5	124.8	24.9	74.9	59.9	74.9

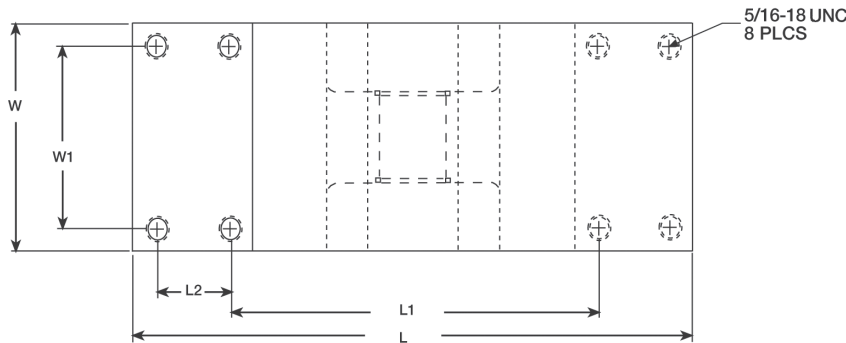
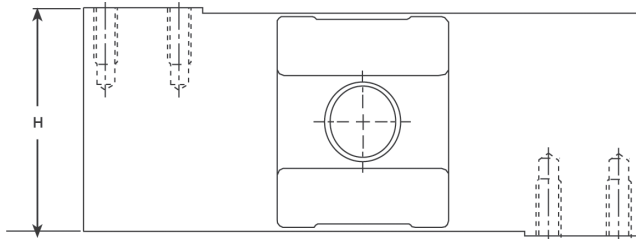

Interchangeable Products

- RICE LAKE WEIGHING SYSTEMS
RLPWM12.....page 161
 - RICE LAKE WEIGHING SYSTEMS
RL1250*
 - VPG® TEDEA-HUNTLEIGH®
1250* page 322
- * Environmentally sealed*

Specifications

- Full Scale Output:**
2.0 mV/V
- Output Resistance:**
960 (± 50) ohm
- Input Resistance:**
1,100 (± 50) ohm
- Material/Finish:**
Stainless steel
- Temperature:**
Compensated:
14 °F to 104 °F (-10 °C to 40 °C)
Operating:
0 °F to 150 °F (-18 °C to 65 °C)
- Seal Type:**
Hermetically sealed, IP69K
- Safe Overload:**
200% full scale
- Safe Sideload:**
100% full scale
- Rated Excitation:**
5 to 15 VDC
- Combined Error:**
0.02% full scale
- Insulation Resistance:**
5,000 megohm
- Deflection at Capacity:**
0.015 in
- Cable Length:**
10 ft
- Cable Diameter:**
0.196 in
Polyurethane jacket
- Cable Color Code:**
Green +Excitation
Black -Excitation
White +Signal
Red -Signal
Yellow Shield
- Max Platform Size:**
39 × 39 in
- Warranty:**
One-year limited
- Approvals:**
FM
NTEP
OIML



Picture is a representation of actual product.

Approvals



Order Information

Load Rating	Part #	Est. Weight	Price
NTEP Certified			
10 kg	41821	3lb	\$328.00
15 kg	36219	3lb	\$328.00
30 kg	36220	3lb	\$328.00
50 kg	36221	3lb	\$328.00
75 kg	36222	3lb	\$328.00
Non-NTEP Certified			
100 kg	36223	3lb	\$328.00
200 kg	36224	4lb	\$492.00

Dimensions

Rated Capacity	H	H1	L	L1	L2	L3	L4	L6	W	T
kg/mm										
10 to 100	40.0	10.0	150.0	100.0	19.0	32.0	6.0	20.0	25.4	1/4-20 UNC x 19.1DP
200	40.0	10.0	150.0	100.0	19.0	32.0	6.0	20.0	38.1	1/4-20 UNC x 19.1DP

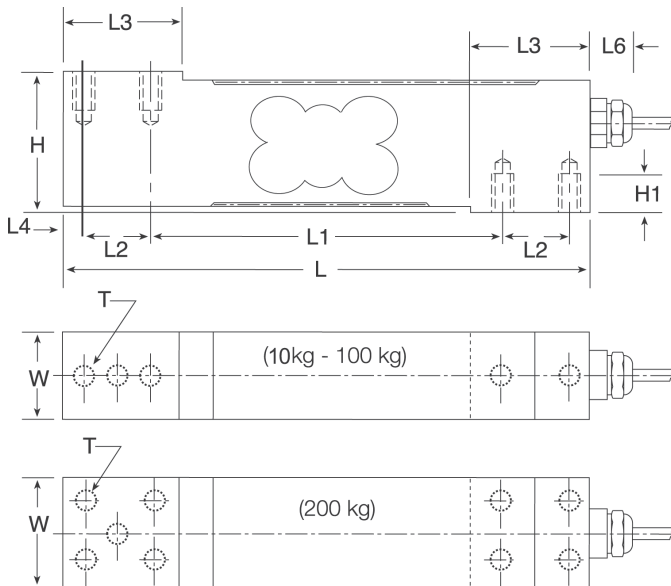

Interchangeable Products

RICE LAKE WEIGHING SYSTEMS
 RL1385..... page 167

Specifications

Full Scale Output:
2.0 mV/V

Output Resistance:
330 (± 25) ohm

Input Resistance:
390 (± 20) ohm

Material/Finish:
Stainless steel

Temperature:
Compensated:
14 °F to 104 °F (-10 °C to 40 °C)
Operating:
0 °F to 150 °F (-18 °C to 65 °C)

Seal Type:
Environmentally sealed, IP67

Safe Overload:
200% full scale

Safe Sideload:
100% full scale

Rated Excitation:
5 to 15 VDC

Combined Error:
0.02% full scale

Insulation Resistance:
5,000 megohm

Cable Length:
10 ft

Cable Diameter:
0.196 in
Polyurethane jacket

Cable Color Code:
Green +Excitation
Black -Excitation
White +Signal
Red -Signal
Yellow Shield

Max Platform Size:
18 x 18 in

Warranty:
One-year limited

Approvals:
FM
NTEP
OIML

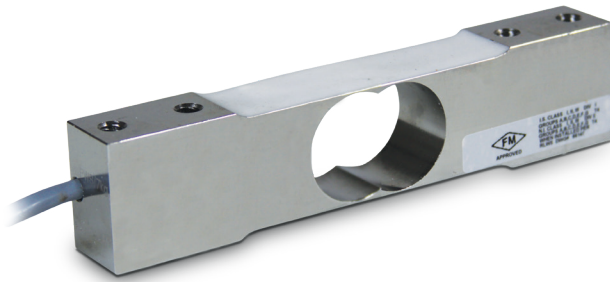

Picture is a representation of actual product.

Approvals



Order Information

Load Rating	Part #	Est. Weight	Price
7 kg	202686	2 lb	\$328.00
10 kg	202687	2 lb	\$328.00
30 kg	202688	2 lb	\$328.00
60 kg	202689	2 lb	\$328.00
100 kg	202690	2 lb	\$328.00
150 kg	202691	2 lb	\$328.00

Dimensions

Rated Capacity	A	B	C	D	E	F	G
kg/mm							
7 to 10	18.2	140.0	19.0	6.4	88.9	1/4-20 UNC	30.0
30 to 60	24.5	140.0	19.0	6.4	88.9	1/4-20 UNC	30.0
100 to 150	30.8	140.0	22.4	7.8	79.3	3/8-16 UNC	30.0

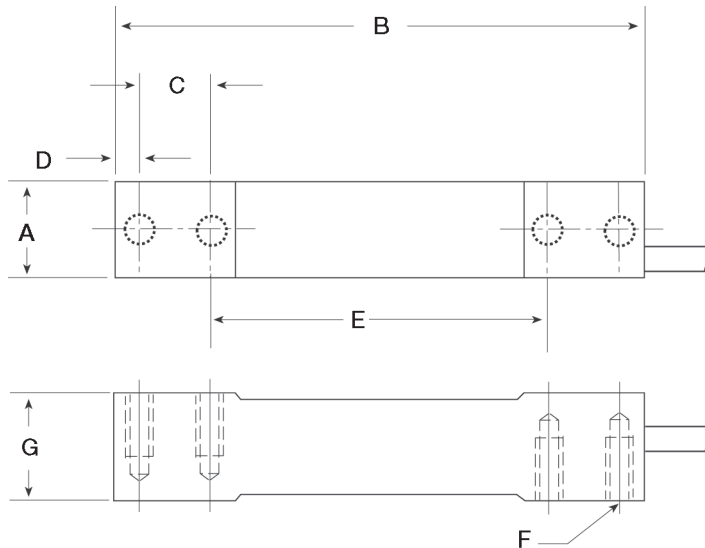

Interchangeable Products

- RICE LAKE WEIGHING SYSTEMS
- RL1380.....page 166
- HBK®
- PWS.....page 231

Specifications

- Full Scale Output:** 2 mV/V
- Output Resistance:** 350 (± 10) ohm
- Input Resistance:** 385 (± 15) ohm
- Material Finish:** Stainless Steel
- Temperature:** Compensated: 14 °F to 104 °F (-10 °C to 40 °C)
Operating: 0 °F to 150 °F (-18 °C to 65 °C)
- Seal Type:** Environmentally Sealed, IP67
- Safe Overload:** 150% full scale
- Rated Excitation:** 5 to 10 VDC
- Combined Error:** 0.02% full scale
- Insulation Resistance:** 5,000 megohm
- Cable Length:** 10 ft
- Cable Diameter:** 0.140 in
Polyurethane jacket
- Color Code:** Green +Excitation
Black -Excitation
White +Signal
Red -Signal
Yellow Shield
- Max Platform Size:** 7 to 30 kg: 350 × 350 mm
60 to 150 kg: 450 × 450 mm
- Warranty:** One-year limited
- Approvals:** FM
NTEP
OIML

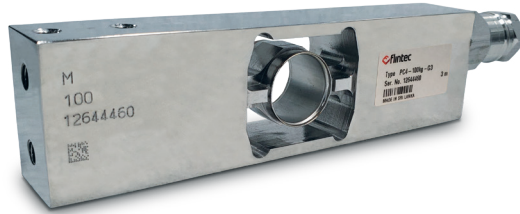

Picture is a representation of actual product.

Approvals



Order Information

Load Rating	Part #	Est. Weight	Price
10 kg	202692	3 lb	\$630.00
20 kg	202693	3 lb	\$630.00
50 kg	202694	3 lb	\$630.00
100 kg	202695	3 lb	\$630.00

Dimensions

Rated Capacity	A	B	C	D	E	F	G	H
kg/mm								
10 to 100	19.0	100.0	6.0	19.1	40.0	25.0	150.0	40.0

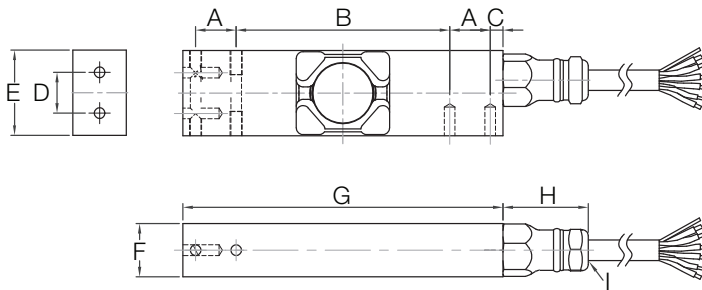

Interchangeable Products

RICE LAKE WEIGHING SYSTEMS
RLPWM15HE..... page 155
 HBK®
PW15AH* page 230
 *350 Ohm

Specifications

Full Scale Output:
2 mV/V

Output Resistance:
960 (± 50) ohm

Input Resistance:
1100 (± 50) ohm

Material:
Stainless Steel

Temperature :
Compensated:
14 °F to 104 °F (-10 °C to 40 °C)
Operating:
0 °F to 150 °F (-18 °C to 65 °C)

Seal Type:
Hermetically sealed, IP69K

Safe Overload:
150% full scale

Rated Excitation:
5 to 10 VDC

Combined Error:
0.02% full scale

Insulation Resistance:
> 5,000 megohm

Cable Length:
10 ft

Color Code:
Green +Excitation
Black -Excitation
White +Signal
Red -Signal
Blue +Sense
Brown -Sense
Yellow Shield

Max Platform Size:
500 × 400 mm

Warranty:
One-year limited

Approvals:
FM
NTEP
OIML



PC6

Stainless Steel, Hermetically Sealed, NTEP Certified 1:5,000 Class III Single Cell, OIML C3, IP69K

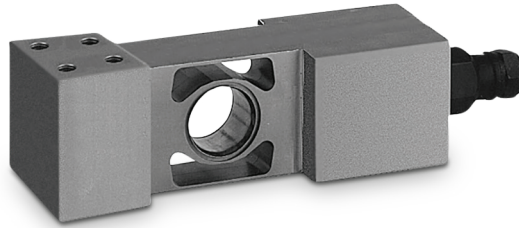

Picture is a representation of actual product.

Approvals



Order Information

Load Rating	Part #	Est. Weight	Price
20 kg	36225	3 lb	\$640.00
50 kg	36226	3 lb	\$640.00
100 kg	36227	3 lb	\$640.00
200 kg	36228	3 lb	\$640.00

Dimensions

Rated Capacity	H	H1	L	L1	L2	L3	L4	W	W1	T
kg/mm										
20 to 200	48.0	45.5	123.0	41.0	15.2	67.6	17.8	30.1	15.2	8 × M6/15 DP

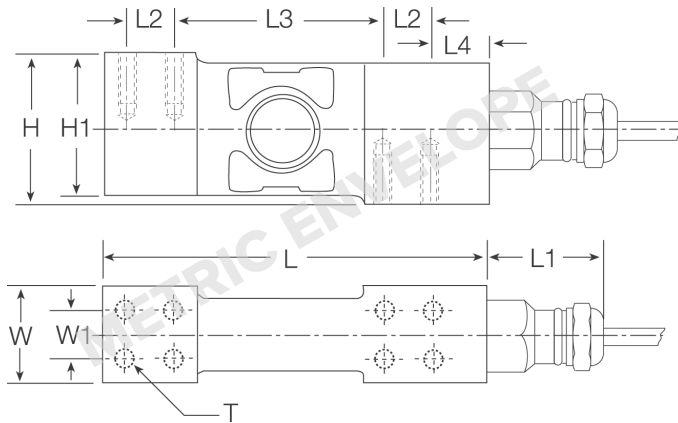

Interchangeable Products

RICE LAKE WEIGHING SYSTEMS
RLPC6 page 154

Specifications

- Full Scale Output:**
2.0 mV/V
- Output Resistance:**
960 (± 50) ohm
- Input Resistance:**
1,100 (± 50) ohm
- Material/Finish:**
Stainless steel
- Temperature:**
Compensated range
14 °F to 104 °F (-10 °C to 40 °C)
Operating range
0 °F to 150 °F (-18 °C to 65 °C)
- Seal Type:**
Hermetically sealed, IP69K
- Safe Overload:**
200% full scale
- Safe Sideload:**
100% full scale
- Rated Excitation:**
5 to 10 VDC (15 V maximum)
- Combined Error:**
0.02% full scale
- Insulation Resistance:**
5,000 megohm
- Cable Length:**
3 m
- Cable Color Code:**
Green +Excitation
Black -Excitation
White +Signal
Red -Signal
Yellow Shield
- Max Platform Size:**
24 × 24 in
- Warranty:**
One-year limited
- Approvals:**
FM
NTEP
OIML



Picture is a representation of actual product.

Approvals



Order Information

Load Rating	Part #	Est. Weight	Price
100 kg	161719	6 lb	\$742.00
250 kg	161720	6 lb	\$742.00
500 kg	161721	6 lb	\$742.00

Dimensions

Rated Capacity	H	H1	L	L1	L2	L3	L4	W	W1	T
kg/in										
100 to 500	2.88	1.00	5.91	3.41	2.92	1.50	0.63	1.50	1.00	M8

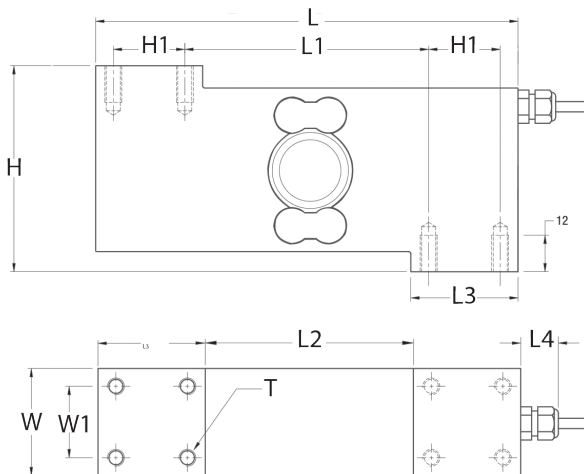

Interchangeable Products

VPG® TEDEA-HUNTLEIGH®
1510..... page 324

Specifications

- Full Scale Output:**
2 mV/V ±5%
- Output Resistance:**
350 (± 10) ohm
- Input Resistance:**
380 (± 20) ohm
- Material/Finish:**
Stainless steel construction with electro-polished finish
- Temperature:**
Operating:
0 °F to 150 °F (-18 °C to 65 °C)
- Seal Type:**
Hermetically sealed, IP69K
- Safe Overload:**
150% full scale
- Rated Excitation:**
5 to 15 VDC
- Insulation Resistance:**
5,000 megohm
- Cable Length:**
3 m
- Cable Color Code:**
Green +Excitation
Black -Excitation
White +Signal
Red -Signal
Blue +Sense
Brown -Sense
Yellow Shield
- Max Platform Size:**
600 × 600 mm
- Warranty:**
One-year limited
- Approvals:**
OIML

FLINTEC®

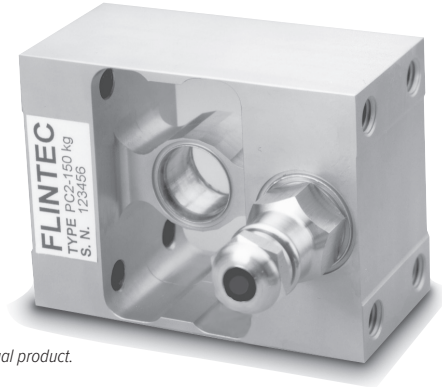

Picture is a representation of actual product.

Approvals



Order Information

Load Rating	Part #	Est. Weight	Price
150 kg	41176	2 lb	\$1,160.00

Dimensions

Rated Capacity	A	B	C	D	E	F	G	H
kg/mm								
150	101.6	75.0	M10	13.0	41.0	49.5	57.2	31.8

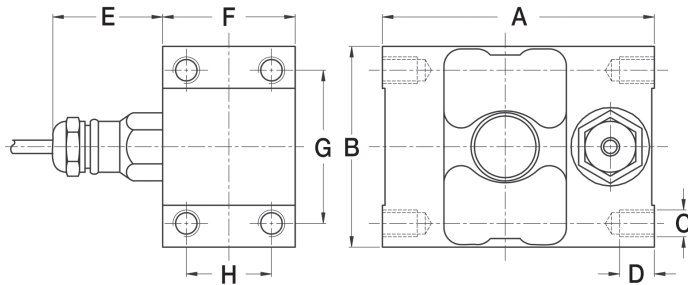

Specifications

- Full Scale Output:**
2.0 mV/V
- Output Resistance:**
960 (± 50) ohm
- Input Resistance:**
1,100 (± 50) ohm
- Material/Finish:**
Stainless steel
- Temperature:**
Operating:
0 °F to 150 °F (-18 °C to 65 °C)
- Seal Type:**
Hermetically sealed, IP68
- Safe Overload:**
200% full scale
- Safe Sideload:**
100% full scale
- Rated Excitation:**
5 to 15 VDC
- Combined Error:**
0.02% full scale
- Insulation Resistance:**
5,000 megohm
- Cable Length:**
10 ft
- Cable Diameter:**
0.196 in
Polyurethane jacket
- Cable Color Code:**
Green +Excitation
Black -Excitation
White +Signal
Red -Signal
Blue +Sense
Brown -Sense
Yellow Shield
- Warranty:**
One-year limited
- Approvals:**
FM

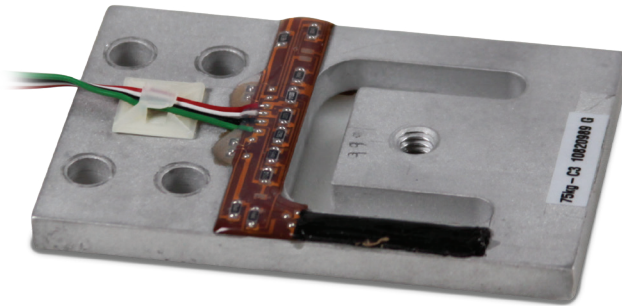

Interchangeable Products

RICE LAKE WEIGHING SYSTEMS
 RLBP..... page 173

Specifications

- Full Scale Output:**
1 mV/V
mV/V/ohm calibration
- Output Resistance:**
1,000 (± 10) ohm
- Input Resistance:**
1,180 (± 50) ohm
- Material/Finish:**
Aluminum
- Temperature:**
Operating:
0 °F to 150 °F (-18 °C to 65 °C)
- Seal Type:**
Environmentally sealed, IP65
- Safe Overload:**
150% full scale
- Rated Excitation:**
5 to 10 VDC
- Combined Error:**
0.060% full scale
- Insulation Resistance:**
5,000 megohm
- Cable Length:**
1.5 m
- Cable Color Code:**
Green +Excitation
Black -Excitation
White +Signal
Red -Signal
Yellow Shield
- Warranty:**
One-year limited

Order Information

Load Rating	Part #	Est. Weight	Price
15 kg	96361	1 lb	\$85.00
37.5 kg	96362	1 lb	\$90.00
75 kg	96363	1 lb	\$96.00
150 kg	96364	1 lb	\$108.00

Dimensions

Rated Capacity	L1	L2	L3	L4	L5	W1	W2	H1	D1	D2	Deflection (mm) at E max
kg/mm											
15	70.0	4.9	14.0	28.0	23.7	39.0	27.8	4.1	7.6	5.1	0.3
37.5	76.2	6.0	15.0	29.3	27.0	44.5	30.0	4.8	7.6	6.6	0.4
75	84.4	6.4	15.0	34.0	27.7	54.8	30.0	6.4	7.6	6.6	0.4
150	107.3	7.8	22.9	45.9	38.4	69.9	44.5	7.9	9.1	8.1	0.6

