

Rice Lake OS-10/OS-25/OS-45

Suspended Scale

COMPANION
ANIMAL SCALES



Carrying case



Sturdy steel
closed loop s-hook
for safety



Standard Features

- Hold function
- Units of measure: lb/lb-oz/kg
- Adjustable automatic shut-off
- Ergonomic handheld design
- Battery operated, two AA batteries (included)
- Carrying case and top s-hook (included)
- Captured lower hook, removable upper hook (both hooks included)

Specifications

Capacity:

OS-10:

- 22 lb × 0.02 lb
- 22 lb × 0.25 oz
- 10 kg × 0.01 kg

OS-25:

- 55 lb × 0.05 lb
- 55 lb × 0.5 oz
- 25 kg × 0.02 kg

OS-45:

- 99 lb × 0.1 lb
- 99 lb × 1 oz
- 45 kg × 0.05 kg

Power:

Two AA batteries (included)

Temperature:

Operating:
32 °F to 104 °F (0 °C to 40 °C)

Warranty:

One-year limited

Approvals:

CE Approved

Approvals



Part Number/Price

Part #	Model	Capacity	Est. Weight	Price
130292	OS-10	10 × 0.01 kg (22 × 0.02 lb) (22 lb × 1/4 oz)	1.25 lb	Consult
130293	OS-25	25 × 0.02 kg (55 × 0.05 lb) (55 lb × 1/2 oz)	1.25 lb	Consult
130294	OS-45	45 × 0.05 kg (99 × 0.1 lb) (99 lb × 1 oz)	1.25 lb	Consult

Dimensions

	Inches	Centimeters
A	14.30	36.3
B	3.60	9.1
C	1.30	3.3
D	11.60	29.5

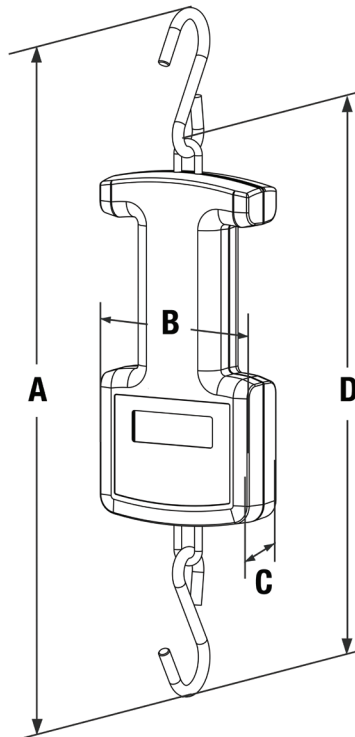

Rice Lake VS-10



Standard Features

- Large 1-inch LCD display
- Unit of measure locking
- Recall function to view last weight
- Automatic shut-off for long battery life

Specifications

Capacity:

44 lb × 0.5 oz (20 kg × 10 g)

Power:

Four AA alkaline batteries (included) or AC adapter (included)

Battery Type

Four AA alkaline (included)

Measuring Tape:

0 to 22.5 in (0 to 57 cm)

Approvals:

AC adapter: cULus

Warranty:

Two-year limited

Part Number/Price

Part #	Model #	Capacity	Price
204394	Rice Lake VS-10	44 lb × 0.5 oz (20 kg × 10 g), includes 120 VAC adapter	Consult

Shipping Weight

Part #	Model #	L (in)	W (in)	H (in)	Package Wgt. (lb)	Dim Wgt. (lb)	Shipping Wgt. (lb)
204394	Rice Lake VS-10	27	18	7	10	21	21

Dimensions

	Inches	Centimeters
A	3.90	9.9
B	15.00	38.1
C	3.10	7.8
D	23.60	59.9
E	11.00	27.9

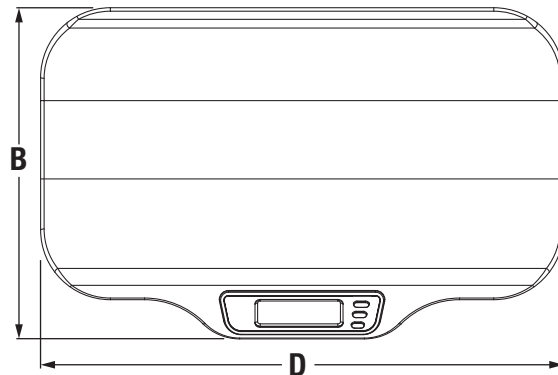
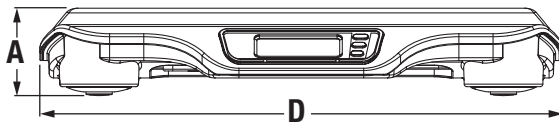
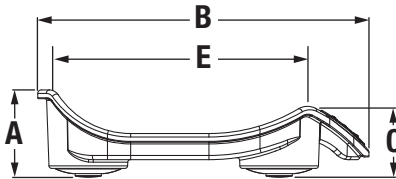

COMPANION
ANIMAL SCALES

Rice Lake VS-11



DUAL RANGE

Standard Features

- Large 1-inch LCD display
- Dual-range capacity for increased precision
- Accuracy within 5 g
- Unit of measure locking
- Recall function to view last weight
- Automatic shut-off for long battery life
- Built-in measuring tape

Specifications

Capacity:

0 to 22 lb × 0.2 oz (0 to 10 kg × 5 g)
22 to 44 lb × 0.5 oz (10 to 20 kg × 10 g)

Power:

Four AA alkaline batteries (included)
or AC adapter (included)

Battery Type:

Four AA alkaline (included)

Measuring Tape:

0 to 22.5 in (0 to 57 cm)

Approvals:

AC adapter: cULus

Warranty:

Two-year limited

COMPANION
ANIMAL SCALES

Part Number/Price

Part #	Model #	Capacity	Price
204395	Rice Lake VS-11	0 to 22 lb × 0.2 oz, 22 to 44 lb × 0.5 oz (0 to 10 kg × 5 g, 10 to 20 kg × 10 g) includes 120 VAC adapter	Consult

Shipping Weight

Part #	Model #	L (in)	W (in)	H (in)	Package Wgt. (lb)	Dim Wgt. (lb)	Shipping Wgt. (lb)
204395	Rice Lake VS-11	27	18	7	10	21	21

Dimensions

	Inches	Centimeters
A	3.90	9.9
B	15.00	38.1
C	3.10	7.8
D	23.60	59.9
E	11.00	27.9

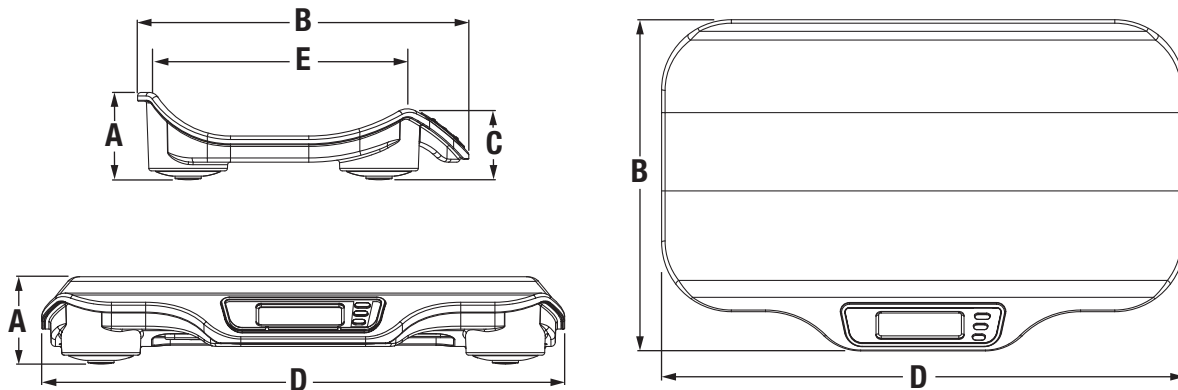

Rice Lake VS-12

DUAL RANGE



Standard Features

- LCD display
- Dual-range capacity for increased precision
- Unit of measure locking
- Automatic shut-off for long battery life
- Motiontrap™ movement compensation technology
- Built-in measuring tape

Specifications

Capacity:

Range 1: 0 to 10 lb × 0.05 oz
(0 to 5 kg × 1 g)
Range 2: 10 to 33 lb × 0.1 oz
(5 to 15 kg × 2 g)

Power:

12 VDC, provided by six AA lithium batteries (included) or AC adapter (optional)

Battery Type:

Six Li-FeS₂ batteries

Temperature:

Operating:
50 °F to 95 °F (14 °C to 35 °C)

Display:

5-digit LCD display, 0.75 in (1.9 cm) digit height

Approvals:

c-Met E113986

Warranty:

Two-year limited

Approvals



Part Number/Price

Part #	Model #	Capacity	Price
204398	Rice Lake VS-12	0 to 10 lb × 0.05 oz, 10 to 33 lb × 0.1 oz (0 to 5 kg × 1 g, 5 to 15 kg × 2 g) 120V/230V	Consult

Shipping Weight

Part #	Model #	L (in)	W (in)	H (in)	Package Wgt. (lb)	Dim Wgt. (lb)	Shipping Wgt. (lb)
204398	Rice Lake VS-12	18	28	11	25	40	40

Options/Accessories

Part #	Description	Price
165138	AC adapter, input voltage 100 to 240 V, c-Met, medical grade	Consult

Dimensions

	Inches	Centimeters
A	23.94	60.8
B	16.95	43.1
C	6.29	16.0
D	10.50	26.7
E	3.11	7.9
F	13.34	33.9

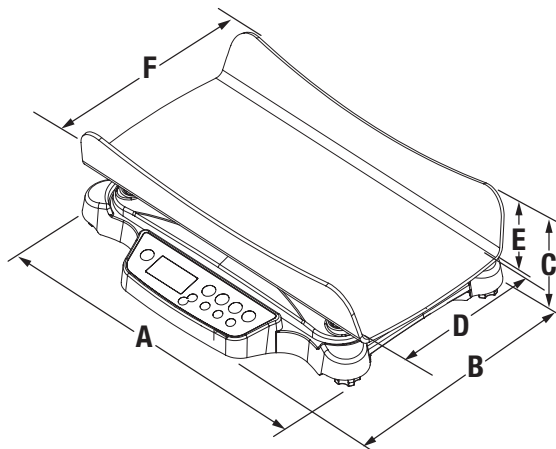

COMPANION
ANIMAL SCALES

Rice Lake VS-20

COMPANION
ANIMAL SCALES



Standard Features

- Push-button LCD display
- Large, stable scale base
- Nonslip rubber mat, removable for cleaning
- Unit of measure toggle or locking
- Motiontrap™ movement compensation technology
- USB communication
- Hold function
- Tare function
- Factory calibrated

Specifications

Capacity:

550 × 0.2 lb (250 × 0.1 kg)

Power:

9 VDC, provided by six AA alkaline batteries (included) or AC adapter (optional)

Battery Type:

Six AA alkaline (included)

Battery Use:

25 hours continuous use with batteries
Automatic power-off can be configured

Temperature:

Operating:
50 °F to 104 °F (10 °C to 40 °C)

Display:

5-digit LCD display, 0.75 in (1.9 cm) digit height

Warranty:

Two-year limited

Part Number/Price

Part #	Model #	Capacity	Price
Consult	Rice Lake VS-20	550 × 0.2 lb (250 kg × 0.1 kg) with USB	Consult

Shipping Weight

Part #	Model #	L (in)	W (in)	H (in)	Package Wgt. (lb)	Dim Wgt. (lb)	Shipping Wgt. (lb)
Consult	Rice Lake VS-20	12.7	22.4	14.7	25	37	37

Options/Accessories

Part #	Description	Price
133077 †	9 VDC adapter, 120 V/230 V auto switching	Consult
102508 ††	9 VDC adapter, 230 V	Consult
81076	Epson TM-U220 tape printer	Consult
186830	Printer cable, 25-pin D-Sub male to RJ-45, 6 ft	Consult



† NEMA 1-15 Plug

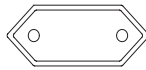

†† CEE 7/16 Plug

Dimensions

	Inches	Centimeters
A	12.70	32.3
B	22.40	56.9
C	14.70	37.4
D	3.00	7.6

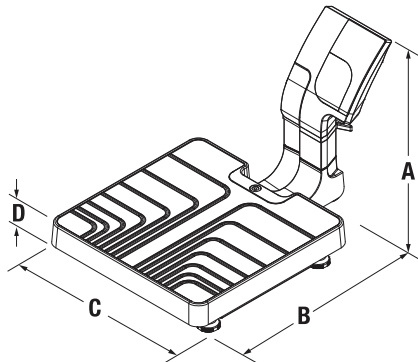

NONSLIP METAL PLATFORM



Standard Features

- Large LCD display
- Antimicrobial keypad
- Two wheels for portability
- Dual ramp
- Nonslip platform
- Motiontrap™ movement compensation technology
- Unit of measure toggle or locking
- Serial and USB data communication port
- Tare function
- Hold function
- Factory calibrated
- Easy to store, folded depth is 11.75 in (29.8 cm)

Specifications

Capacity:

1,000 × 0.2 lb (450 × 0.1 kg)

Platform Dimensions:

(L × W × H)
29.50 × 31.50 × 3.15 in

Power:

9 VDC, provided by six AA alkaline batteries (included) or AC adapter (optional)

Battery Type:

Six AA alkaline (included)

Battery Use:

25 hours continuous use with batteries
Automatic power-off can be configured

Display:

5-digit LCD display, 0.75 in (1.9 cm) digit height

Temperature:

Operating:
50 °F to 104 °F (14 °C to 40 °C)

Warranty:

Two-year limited

Part Number/Price

Part #	Model #	Capacity	Price
204403	Rice Lake VS-36	1,000 × 0.2 lb (450 × 0.1 kg)	Consult

Shipping Weight

Part #	Model #	L (in)	W (in)	H (in)	Package Wgt. (lb)	Dim Wgt. (lb)	Shipping Wgt. (lb)
204403	Rice Lake VS-36	51	42	14	102	216	216

Options/Accessories

Part #	Description	Price
79074	Cable, USB 6 ft USB-A (male) to USB-B (male)	Consult
217091	Cable, Communication DB9 (female) to RJ45 (male), 4 conductor	Consult
186830	Cable, RS232 scale to printer, 6 ft, 25-pin D-Sub (male) to RJ45	Consult

Dimensions

	Inches	Centimeters
A	3.15	8.0
B	47.70	121.2
C	37.80	96.0
D	45.30	115.1
E	31.50	80.0
F	29.50	74.9
G	2.40	6.1
H	27.20	69.1

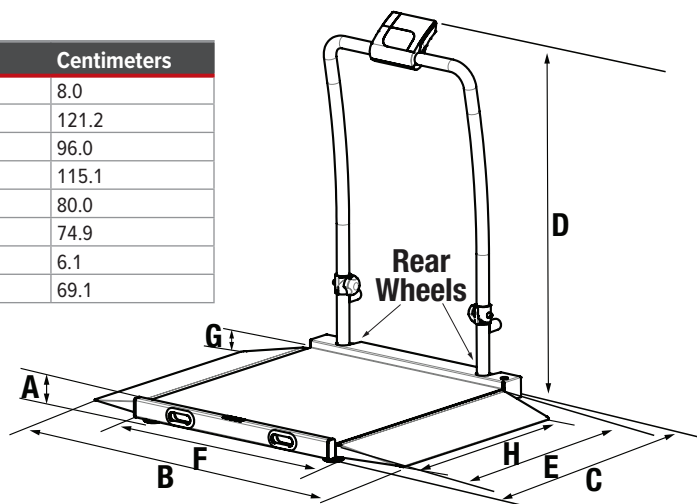

Rice Lake VS-36 in folded position

COMPANION ANIMAL SCALES

Rice Lake VS-34

COMPANION
ANIMAL SCALES



PLASTIC/POLYMER
TOP

Standard Features

- Large LCD display
- Antimicrobial keypad
- Two wheels for portability
- Single ramp
- Nonslip platform
- Motiontrap™ movement compensation technology
- Unit of measure toggle or locking
- Serial and USB communication port
- Tare function
- Hold function
- Factory calibrated
- Easy to store, folded depth is 11.75 in (29.8 cm)

Specifications

Capacity:

1,000 × 0.2 lb (450 × 0.1 kg)

Platform Dimensions Without Ramps:

(L × W × H)

29.50 × 32.00 × 2.40 in

Power:

9 VDC, provided by six AA alkaline batteries (included) or AC adapter (optional)

Battery Type:

Six AA alkaline (included)

Battery Use:

25 hours continuous use with batteries
Automatic power-off can be configured

Display:

5-digit LCD display, 0.75 in (1.9 cm) digit height

Temperature:

Operating:
50 °F to 104 °F (14 °C to 40 °C)

Warranty:

Two-year limited

Part Number/Price

Part #	Model #	Capacity	Price
204405	Rice Lake VS-34	1,000 × 0.2 lb (450 kg × 0.1 kg) with USB	Consult

Shipping Weight

Part #	Model #	L (in)	W (in)	H (in)	Package Wgt. (lb)	Dim Wgt. (lb)	Shipping Wgt. (lb)
204405	Rice Lake VS-34	42	41	14	90	174	174

Options/Accessories

Part #	Description	Price
220767	Heavy-duty mat	Consult
79074	Cable, USB 6 ft USB-A (male) to USB-B (male)	Consult
217091	Cable, Communication DB9 (female) to RJ45 (male), 4 conductor	Consult
186830	Cable, RS232 scale to printer, 6 ft, 25-pin D-Sub (male) to RJ45	Consult

Dimensions

	Inches	Centimeters
A	29.50	74.9
B	32.00	81.3
C	2.40	6.1
D	9.30	23.6
E	37.50	95.3
F	45.00	114.3

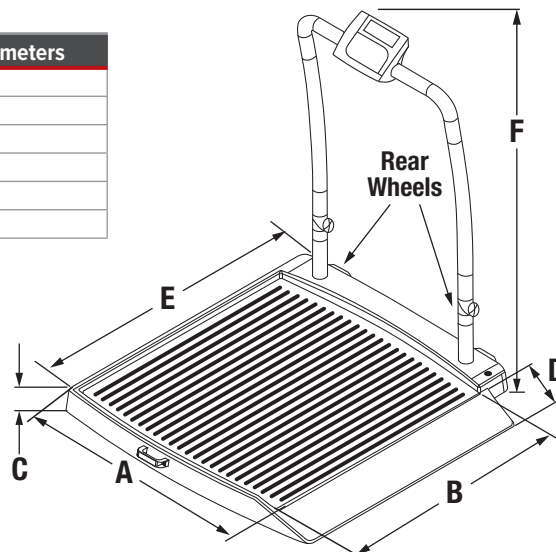

Rice Lake VS-34
in folded position



Optional heavy-duty mat

Rice Lake VS-30



Standard Features

- Large LCD display
- Antimicrobial keypad
- Two wheels for portability
- Single ramp
- Nonslip platform
- Motiontrap™ movement compensation technology
- Unit of measure toggle or locking
- Serial and USB data communication port
- Tare function
- Hold function
- Factory calibrated

Specifications

Capacity:

1,000 × 0.2 lb (450 × 0.1 kg)

Platform Dimensions Without Ramps:

(L × W × H)
29.50 × 32.00 × 2.40 in

Power:

9 VDC, provided by six AA alkaline batteries (included) or AC adapter (optional)

Battery Type:

Six AA alkaline (included)

Battery Use:

25 hours continuous use with batteries
Automatic power-off can be configured

Temperature:

Operating:
50 °F to 104 °F (14 °C to 40 °C)

Cable Length:

7 ft (2.1 m) cable between scale base and indicator

Display:

5-digit LCD display, 0.75 in (1.9 cm) digit height

Warranty:

Two-year limited

COMPANION
ANIMAL SCALES

Part Number/Price

Part #	Model #	Capacity	Price
204396	Rice Lake VS-30	1,000 × 0.2 lb (450 × 0.1 kg) with USB	Consult

Shipping Weight

Part #	Model #	L (in)	W (in)	H (in)	Package Wgt. (lb)	Dim Wgt. (lb)	Shipping Wgt. (lb)
204396	Rice Lake VS-30	45	44	7	78	100	100

Options/Accessories

Part #	Description	Price
220767	Heavy-duty mat	Consult
79074	Cable, USB 6 ft USB-A (male) to USB-B (male)	Consult
217091	Cable, Communication DB9 (female) to RJ45 (male), 4 conductor	Consult
186830	Cable, RS232 scale to printer, 6 ft, 25-pin D-Sub (male) to RJ45	Consult

Dimensions

	Inches	Centimeters
A	29.50	74.9
B	32.00	81.3
C	2.40	6.1
D	9.30	23.6
E	37.50	95.3

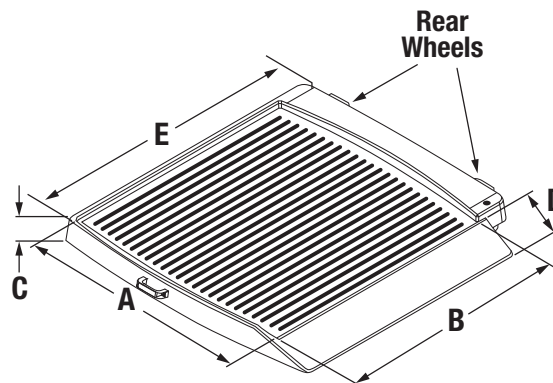

Optional heavy-duty mat

Rice Lake VS-35

COMPANION
ANIMAL SCALES



PLASTIC/POLYMER
TOP

Standard Features

- Large LCD display
- Antimicrobial keypad
- Two wheels for portability
- Dual ramp
- Nonslip platform
- Motiontrap™ movement compensation technology
- Unit of measure toggle or locking
- Serial and USB communication port
- Tare function
- Hold function
- Factory calibrated
- Easy to store, folded depth is 11.75 in (29.8 cm)

Specifications

Capacity:

1,000 × 0.2 lb (450 × 0.1 kg)

Platform Dimensions Without Ramps:

(L × W × H)

29.50 × 32.00 × 2.40 in

Power:

9 VDC, provided by six AA alkaline batteries (included) or AC adapter (optional)

Battery Type:

Six AA alkaline (included)

Battery Use:

25 hours continuous use with batteries
Automatic power-off can be configured

Display:

5-digit LCD display, 0.75 in (1.9 cm) digit height

Temperature:

Operating:
50 °F to 104 °F (14 °C to 40 °C)

Warranty:

Two-year limited

Part Number/Price

Part #	Model #	Capacity	Price
204404	Rice Lake VS-35	1,000 lb × 0.2 lb (450 kg × 0.1 kg) with USB	Consult

Shipping Weight

Part #	Model #	L (in)	W (in)	H (in)	Package Wgt. (lb)	Dim Wgt. (lb)	Shipping Wgt. (lb)
204404	Rice Lake VS-35	51	42	14	102	216	216

Options/Accessories

Part #	Description	Price
220767	Heavy-duty mat	Consult
79074	Cable, USB 6 ft USB-A (male) to USB-B (male)	Consult
217091	Cable, Communication DB9 (female) to RJ45 (male), 4 conductor	Consult
186830	Cable, RS232 scale to printer, 6 ft, 25-pin D-Sub (male) to RJ45	Consult

Dimensions

	Inches	Centimeters
A	48.50	123.2
B	32.00	81.3
C	2.40	6.1
D	9.30	23.6
E	38.00	96.5
F	45.00	114.3
G	29.50	74.9

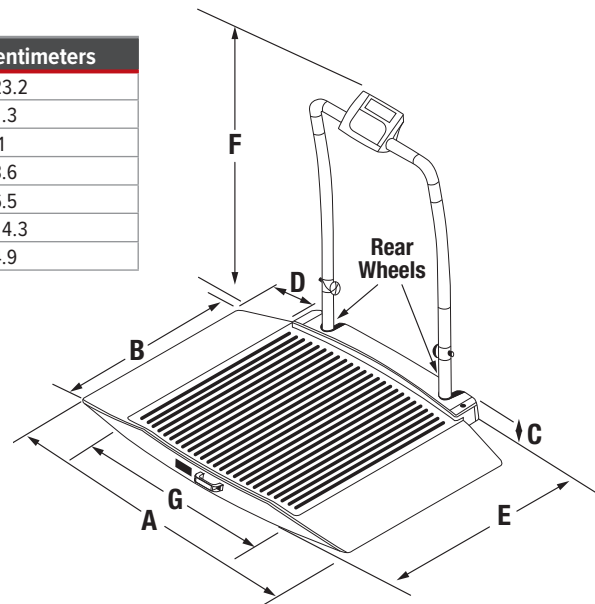

Optional heavy-duty mat

Rice Lake VS-31



Standard Features

- Large LCD display
- Large 1-inch LCD display
- Two wheels for portability
- Dual ramp
- Motiontrap™ movement compensation technology
- Unit of measure toggle or locking
- Serial and USB communication port
- Tare function
- Hold function
- Factory calibrated

Specifications

Capacity:
1,000 × 0.2 lb (450 × 0.1 kg)

Platform Dimensions Without Ramps:
(L × W × H)
29.50 × 32.00 × 2.40 in

Power:
9 VDC, provided by six AA alkaline batteries (included) or AC adapter (optional)

Battery Type:
Six AA alkaline (included)

Battery Use:
25 hours continuous use with batteries
Automatic power-off can be configured

Temperature:
Operating:
50 °F to 104 °F (14 °C to 40 °C)

Cable Length:
7 ft (2.1 m) cable between scale base and indicator

Display:
5-digit LCD display, 0.75 in (1.9 cm) digit height

Warranty:
Two-year limited

COMPANION ANIMAL SCALES

Part Number/Price

Part #	Model #	Capacity	Price
204397	Rice Lake VS-31	1,000 × 0.2 lb (450 × 0.1 kg) with USB	Consult

Shipping Weight

Part #	Model #	L (in)	W (in)	H (in)	Package Wgt. (lb)	Dim Wgt. (lb)	Shipping Wgt. (lb)
204397	Rice Lake VS-31	53	45	7	86	121	121

Options/Accessories

Part #	Description	Price
220767	Heavy-duty mat	Consult
79074	Cable, USB 6 ft USB-A (male) to USB-B (male)	Consult
217091	Cable, Communication DB9 (female) to RJ45 (male), 4 conductor	Consult
186830	Cable, RS232 scale to printer, 6 ft, 25-pin D-Sub (male) to RJ45	Consult

Dimensions

	Inches	Centimeters
A	48.50	123.2
B	32.00	81.3
C	2.40	6.1
D	9.30	23.6
E	38.00	96.5
F	29.50	74.9

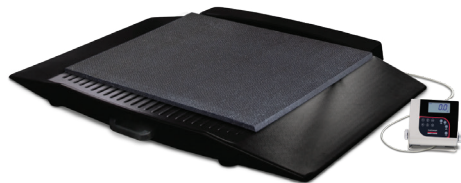
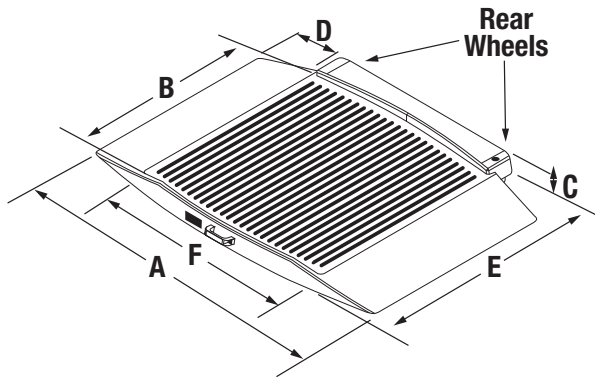

Optional heavy-duty mat