

Belt Scales

TABLE OF CONTENTS

Master™ 311 Belt Scale Weigh Frame	150
<i>Medium to Heavy Capacity Weigh Frame</i>	
Master™ 221DB Belt Scale Weigh Frame	151
<i>Medium to Heavy Capacity Belt Scale</i>	
Master™ 211 Belt Scale Weigh Frame	152
<i>Medium to Heavy Capacity Weigh Frame</i>	
Master™ 14X Belt Scale Weigh Frame	153
<i>Medium to Heavy Capacity Weigh Frame</i>	
Master™ 421 Belt Scale Weigh Frame	154
<i>Light Capacity Weigh Frame</i>	
BCi Belt Scale Weigh Frame	155
<i>In-motion Belt Scale System</i>	
<i>Dimensions</i>	
882D	157
<i>Belt Scale Integrator</i>	
SCT-4XD	159
<i>Belt Scale Integrator</i>	
Speed Sensor	161
Belt Scale Application	162

Product names, logos, brands and other trademarks featured or referred to within this publication are the property of their respective trademark holders.

Master™ 311 Belt Scale Weigh Frame

Medium to Heavy Capacity Weigh Frame



Part Number/Price

Part #	Description	Est. Weight	Price
215021	Master 311 belt scale weigh frame, 18 in belt with 75 kg load cell	125 lb	\$1,300.00
215022	Master 311 belt scale weigh frame, 24 in belt with 75 kg load cell	125 lb	\$1,300.00
215023	Master 311 belt scale weigh frame, 24 in belt with 150 kg load cell	125 lb	\$1,300.00
215025	Master 311 belt scale weigh frame, 30 in belt with 150 kg load cell	125 lb	\$1,400.00
215030	Master 311 belt scale weigh frame, 30 in belt with 250 kg load cell	125 lb	\$1,400.00
215031	Master 311 belt scale weigh frame, 36 in belt with 250 kg load cell	125 lb	\$1,500.00
Consult	Lifting weight kit		Consult

Please complete the Belt Scale Application on page 162 to obtain a quote

Standard Features

- Semi-modular weigh frame design
- Weigh frame without moving parts
- Fits standard conveyors
- Mounts with four bolts
- Requires weigh frame cutting for proper fit
- Minimal modifications to conveyor required

Options

- Galvanized or stainless construction
- Custom widths available
- Custom lifting weights available on request

Applications

- Mining, quarries, bulk material blending, process control and retrofit

Specifications

Belt Width:

18 to 36 in (457 to 914 mm)

Capacity:

1,500 tons per hour

Belt Speed:

Maximum 400 ft/minute (2 m/s)

Inclination:

Maximum 12 degrees

Material:

Powder coated mild steel

Accuracy System:

1%

Load Cell:

RL1218A: 50 kg, 100 kg, 250 kg

Warranty:

One-year limited

Master™ 221DB Belt Scale Weigh Frame

Medium to Heavy Capacity Belt Scale



Part Number/Price

Part #	Description	Est. Weight	Price
163292	221DB belt scale with 50 kg load cells	143 lb	\$3,500.00
163293	221DB belt scale with 100 kg load cells	143 lb	\$3,500.00
163294	221DB belt scale with 200 kg load cells	143 lb	\$3,500.00
202591	221DB stainless steel belt scale with 50 kg load cells	143 lb	\$5,200.00
202592	221DB stainless steel belt scale with 100 kg load cells	143 lb	\$5,200.00
202593	221DB stainless steel belt scale with 200 kg load cells	143 lb	\$5,200.00

Please complete the Belt Scale Application on page 162 to obtain a quote

Standard Features

- Weigh frame is mounted on the outside of conveyor
- Minimal modifications to conveyor are required
- Service friendly
- Friction-free pivot supports
- Two support beams
- Fits standard conveyors
- Mounts with four bolts

Options

- Galvanized or stainless construction

Applications

- Medium to heavy capacity

Specifications

Conveyor Width:

18 to 72 in (457 to 1,829 mm)

Capacity:

3,300 tons per hour

Maximum Belt Speed:

800 ft/minute (4 m/s)

Inclination:

Maximum 25 degrees

Material:

Powder coated mild steel

Accuracy System:

0.5% to 1%

Load Cell:

RL9018SS: 50 kg, 100 kg, 200 kg

Junction Box:

JB4SS

Warranty:

One-year limited

Master™ 211 Belt Scale Weigh Frame

Medium to Heavy Capacity Weigh Frame



Standard Features

- Friction-free pivot points
- One load cell carrier beam
- Fits standard conveyors
- Custom built for each application

Options

- 304/316 Stainless steel
- Dual load cells
- Dual idler
- Custom lifting weights available on request

Applications

- Medium to heavy capacity, mining and agriculture

Specifications

Conveyor Width:
20 to 80 in (500 to 2,000 mm)

Capacity:
3,000 tons per hour

Maximum Belt Speed:
800 ft/minute (4 m/s)

Maximum Inclination:
25 degrees

Material:
Powder coated mild steel

Accuracy System:
0.5%

Load Cell:
RL20001 alloy steel, S-beam
(capacity selected from application)

Warranty:
One-year limited

Part Number/Price

Part #	Description	Price
Consult	Lifting weight kit	Consult

Please complete the Belt Scale Application on page 162 to obtain a quote

Master™ 14X Belt Scale Weigh Frame

Medium to Heavy Capacity Weigh Frame



Standard Features

- Custom built for each application
- Fits standard conveyors
- Multiple idler design
- Inner frame has free-floating platform

Options

- 304 stainless steel
- Two, three or four weigh idlers
- Customer lifting weights available upon request

Applications

- Medium to heavy capacity, mining and aggregate

Specifications

Conveyor Width:

20 to 120 in (500 to 3,000 mm)

Capacity:

20,000 tons per hour

Belt Speed:

1,400 ft/minute (7 m/s)

Inclination:

25 degrees

Material:

Powder coated mild steel

Accuracy Guidelines:

0.25%

Load Cell:

RL20001 alloy steel S-beam
(capacity selected from application)

Warranty:

One-year limited

Part Number/Price

Part #	Description	Price
Consult	Master 142	Consult
Consult	Master 143	Consult
Consult	Master 144	Consult
Consult	Lifting weight kit	Consult

Please complete the Belt Scale Application on page 162 to obtain a quote

Master™ 421 Belt Scale Weigh Frame

Light Capacity Weigh Frame

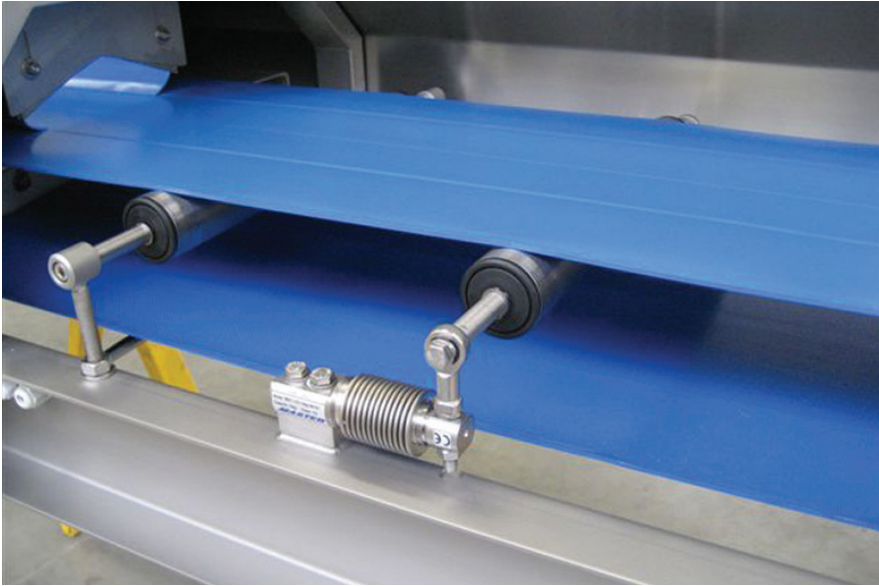

Standard Features

- Ideal for flat belt conveyors
- Roller supported on both sides by load cells
- Open design for easy cleaning

Applications

- Light capacity, food production and light granular materials

Specifications

Conveyor Width:

12 to 60 in (300 to 1,600 mm)

Capacity:

30 tons per hour

Belt Speed:

400 ft/minute (2 m/s)

Inclination:

10 degrees

Material:

Powder coated mild steel, 304/316 stainless steel

Accuracy Systems:

1.0%

Load Cell:

RL9018SS single-ended beam in 10 kg, 20 kg or 50 kg capacities

Warranty:

One-year limited

Part Number/Price

Part #	Description	Price
Consult	421 weigh frame	\$2,575.00

Please complete the Belt Scale Application on page 162 to obtain a quote

BCi Belt Scale Weigh Frame

In-motion Belt Scale System

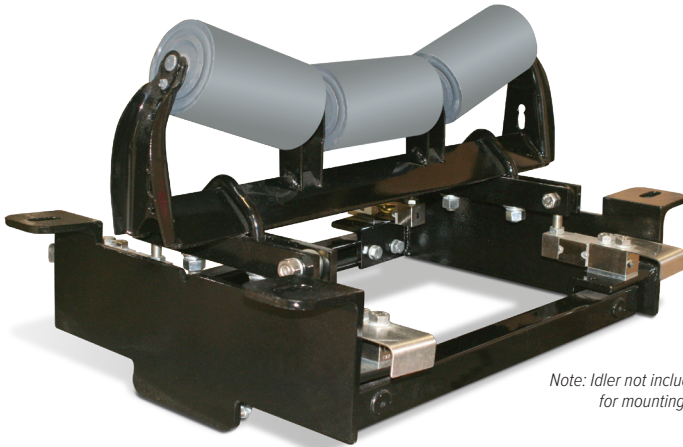

Note: Idler not included. Customer is responsible for mounting idler to weigh frame.

Standard Features

- Fits standard conveyors using CEMA-C idlers
- No moving parts
- Four shear laterally opposed shear beam load cells
- Fabricated with heavy gauge steel
- Minimal conveyor modifications required for installation

Applications

- Mining, quarries, bulk material blending, process control, utilities, truck/berge/rail loading and retrofit

Specifications

Conveyor Widths:

18 to 72 in

Capacity:

Up to 10,000 tons per hour

Belt Speed:

Up to 1,200 feet per minute

Accuracy Guidelines:

Guidelines assume clean belt with automatic tensioning system. Accuracy guidelines are typical. System accuracy may vary depending on environmental influences.

System Accuracy:

Single to two idler system: 0.5% to 1% total error

Part Number/Price

Part #	Description	Est. Belt Width	Capacity	Price
Mild Steel Weigh Frames				
94968	24 in weigh frame	18 in	500 lb	\$2,800.00
95208	30 in weigh frame	24 in	500 lb	\$2,800.00
95209	36 in weigh frame	30 in	500 lb	\$2,800.00
95210	42 in weigh frame	36 in	500 lb	\$2,800.00
95211	48 in weigh frame	42 in	500 lb	\$2,800.00
95212	54 in weigh frame	48 in	500 lb	\$2,800.00
96717	60 in weigh frame	54 in	1,000 lb	\$2,800.00
96718	66 in weigh frame	60 in	1,000 lb	\$2,800.00
96719	72 in weigh frame	66 in	1,000 lb	\$2,800.00
Consult	Light-capacity weigh frames			\$3,185.00
Stainless Steel Weigh Frames				
110839	24 in weigh frame	18 in	500 lb	\$5,300.00
105246	30 in weigh frame	24 in	500 lb	\$5,300.00
110841	36 in weigh frame	30 in	500 lb	\$5,300.00
110842	42 in weigh frame	36 in	500 lb	\$5,300.00
110843	48 in weigh frame	42 in	500 lb	\$5,300.00
110844	54 in weigh frame	48 in	500 lb	\$5,300.00
110845	60 in weigh frame	54 in	500 lb	\$5,300.00
110846	66 in weigh frame	60 in	500 lb	\$5,300.00
110847	72 in weigh frame	66 in	500 lb	\$5,300.00
Consult	Light-capacity weigh frames			\$4,595.00
Weigh Frame Accessories				
126282	V-bolt for 3 in angle iron base idlers set of 2			\$95.00
126283	V-bolt for 4 in angle iron base idlers set of 2			\$105.00

Please complete the Belt Scale Application on page 162 to obtain a quote

BCi Belt Scale Weigh Frame

In-motion Belt Scale System

Dimensions

Part Number	A	B
Mild Steel		
94968	24.00 in	27.50 in
95208	30.00 in	33.50 in
95209	36.00 in	39.50 in
95210	42.00 in	45.50 in
95211	48.00 in	51.50 in
95212	54.00 in	57.50 in
96717	60.00 in	63.50 in
96718	66.00 in	69.50 in
96719	72.00 in	75.50 in

Part Number	A	B
Stainless Steel		
110839	24.00 in	27.50 in
105246	30.00 in	33.50 in
110841	36.00 in	39.50 in
110842	42.00 in	45.50 in
110843	48.00 in	51.50 in
110844	54.00 in	57.50 in
110845	60.00 in	63.50 in
110846	66.00 in	69.50 in
110847	72.00 in	75.50 in

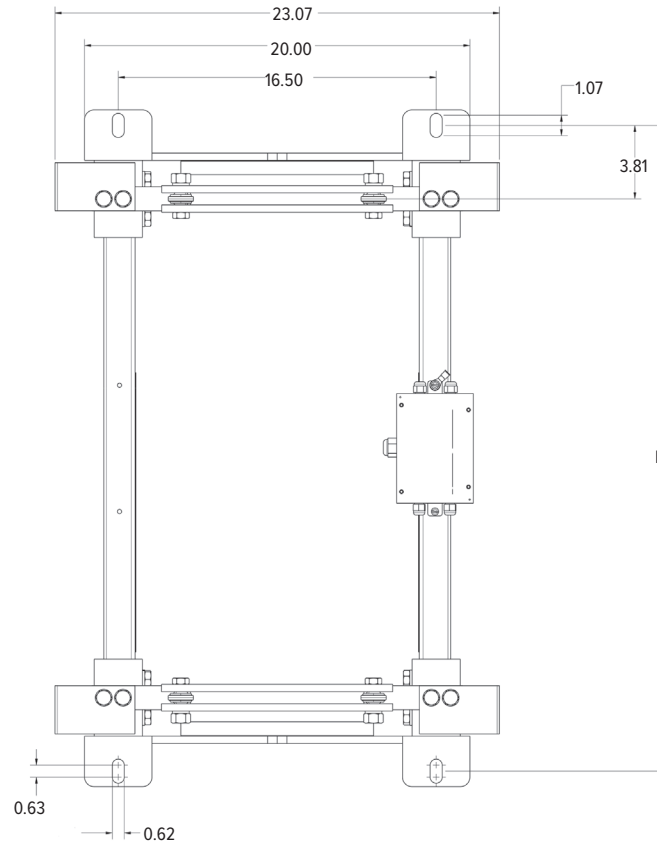
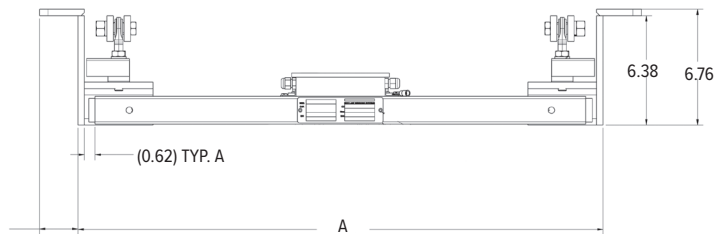

Note: Cables on drawings removed for clarity. Idler mounting hardware is not included in weigh frame; see idler mounting bolts above.



Approvals



Standard Features

- LCD display
- Hardware slot for two option cards
- Operator access to audit trail, preset tare, accumulator, time and date and setpoints through menu keys
- Password protected audit trail tracking for configuration and calibration changes
- Setpoints for control and alarms
- Four onboard digital I/O channels
- Four programmable ticket formats up to 1,000 characters
- Filter settings for noise
- Speed inputs

Part Number/Price

Part #	Description	Price
Integrators		
177708	120 VAC	\$2,115.00
180847	220 VAC Euro power cord	\$2,115.00
184683	9 to 36 VDC	\$2,275.00

Options/Accessories

Part #	Description	Price
190527	Digital I/O	\$365.00
190528	Single analog	\$425.00
190529	Relay interface, not for totalizer pulse count output	\$470.00
177850	Panel mount option 880	\$255.00
197724	Overlay, clear protective	\$85.00
Network Cards		
190530	EtherNet/IP	\$620.00
190531	DeviceNet	\$620.00
190532	PROFINET	\$620.00
190534	PROFIBUS	\$620.00
190533	Modbus TCP/IP	\$620.00
190535	EtherCAT	\$620.00

Please complete the Belt Scale Application on page 162 to obtain a quote

Specifications

Power

Input voltages: 100 to 240 VAC; 9 to 36 VDC
Input frequency: 50/60 Hz

Power Consumption:

AC: 15 watts; DC: 20 watts

Excitation Voltage:

10 VDC 8 × 350 ohm (16 × 700 ohm) load cells

Analog Signal Input Range:

-45 mV to 45 mV

Analog Signal Sensitivity:

0.3 μV/graduation minimum at 7.5 Hz;
1.0 μV/graduation typical at 120 Hz

Sample Rate:

7.5 to 120 Hz, software selectable

Resolution:

Internal: 8,000,000 counts 23-bit
Display: 100,000

System Linearity:

± 0.01% full scale

Digital I/O:

Four I/O onboard primary keys, pseudo functions,
batching functions

Communication Ports:

RS-232 full duplex or RS-485 half duplex; USB 2.0
Micro B connector; Ethernet TCP/IP

Pulse Input:

Dual inputs for redundancy

Display:

LCD display, 0.8 in, seven-digit, seven-segment
weight display, 3 × 20 pixelated prompt area

Annunciators:

Load, total, rate, speed, zero

Keys/Buttons:

Flat membrane panel, tactile feel

Temperature:

Industrial: 14 °F to 122 °F (-10 °C to 50 °C)

Dimensions:

(L × W × H)
9.93 × 4.00 × 8.94 in

Weight:

12 lb (5.4 kg)

Rating/Material:

IP66
Stainless steel

Warranty:

Two-year limited

EMC Immunity:

18 KV, 10 V/m

Approvals:

CE Approved
cULus Listed

882D

Belt Scale Integrator

Dimensions

882D Belt Scale Integrator			
A	9.93 in (252 mm)	F	0.63 in (16 mm)
B	8.10 in (206 mm)	G	4.31 in (110 mm)
C	6.50 in (165 mm)	H	4.14 in (105 mm)
D	8.94 in (227 mm)	I	4.32 in (110 mm)
E	0.68 in (17 mm)		

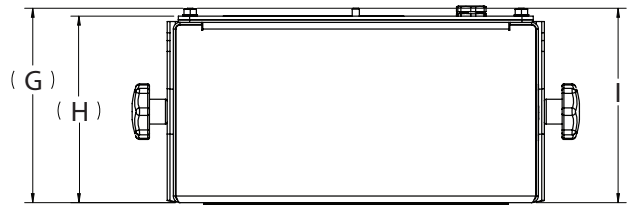
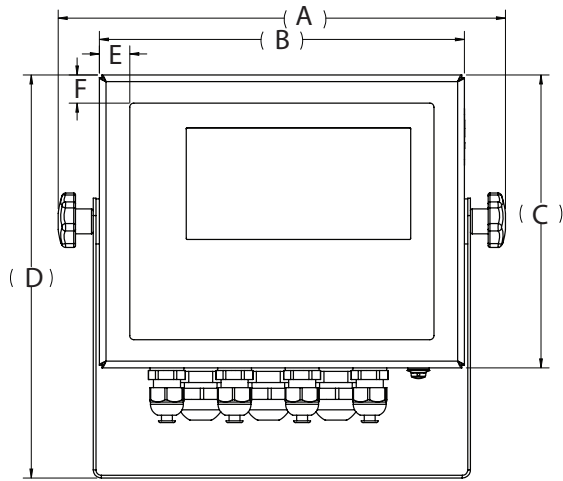

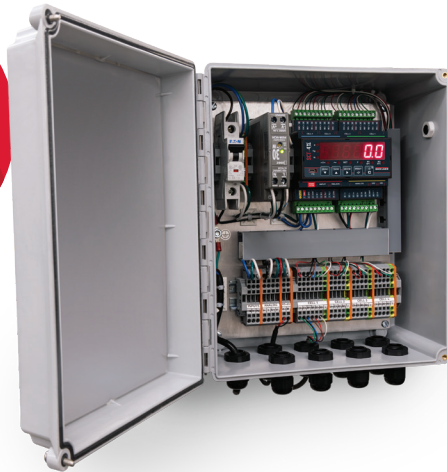

Specifications

- Power:**
12 to 24 VDC
- Power Consumption:**
5 W
- Excitation Voltage:**
5 VDC, 120 mA (up to 16 × 350 ohm cells)
- Analog Signal Input Range:**
±39 mV
- Analog Signal Sensitivity:**
0.3 μV/graduation minimum
- Sample Rate:**
Single-channel up to 2,600 Hz, software selectable
4 channels up to 100 Hz, software selectable
- Analog Output (if equipped):**
Opt. isolated, 16-bit
0 to 20 mA, 4 to 20 mA (maximum 350 ohm)
0 to 5 VDC, 0 to 10 VDC (minimum 10,000 ohm)
- Digital I/O:**
Two inputs: 12/24 VDC
Two outputs: 150 mA 48 VAC/150 mA 60 VDC
- Communication Ports:**
(1) RS-485 half duplex, (1) RS-232 full duplex
1 USB Micro B connector (device)
for PC configuration
- Pulse Input:**
Dual inputs for redundancy
- Display:**
Six-digit 0.31 in (8 mm), red LED
- Keys/Buttons:**
Flat membrane panel, tactile feel
- Dimensions:**
(L × W × H)
Overall: 10.5 × 6.26 × 12.5 in
(266 × 159 × 318 mm)
- Mounting Tabs:**
8.0 × 13.12 in
(203 × 333 mm)
- Weight:**
27 lb
- Rating/Material:**
NEMA 4X (if using supplied enclosure)
- Warranty:**
One-year limited
- Approvals:**
CE-M EN 45501

Standard Features

- Manage up to four load cells (one scale)
- Dual encoders and outputs for automatic test weight application
- Micro-USB communication port for configuration, diagnostics and data backup (RL Tools Software)
- All data and adjustments of each scale are available through integrated fieldbus (not available on AN models)
- Integrated web server on fieldbus models* allows complete diagnostics, calibration and remote configuration
- Removable terminal blocks to simplify wiring in the electrical panel
- Power supply circuit with protections, specific for industrial environment

Options

- 1280 terminal with web server and system configuration menus
- Fieldbus: EtherNet/IP, PROFINET, Modbus TCP/IP
- Analog output

Part Number/Price

Part #	Description	Price
Integrator Only		
225171	Digitizer only, 4 channel weight transmitter with Belt Scale Integrator firmware - no power supply or enclosure	\$1,300.00
225172	Modbus TCP/IP, 4 channel weight transmitter with Belt Scale Integrator firmware	Consult
225173	PROFINET, 4 channel weight transmitter with Belt Scale Integrator firmware	Consult
225174	EtherNet/IP, 4 channel weight transmitter with Belt Scale Integrator firmware	Consult
Integrator with Enclosure		
226132	Analog output, 24 VDC power supply, terminal blocks	Consult
226133	Modbus TCP/IP, 24 VDC power supply, terminal blocks	Consult
226134	PROFINET, 24 VDC power supply, terminal blocks	Consult
226135	EtherNet/IP, 24 VDC power supply, terminal blocks	Consult

Options/Accessories

Part #	Description	Price
Consult	1280 terminal, 7-inch touch screen and tactile keypad, universal enclosure with tilt stand	Consult
Consult	1280 terminal, 7-inch touch screen (only) for panel/surface mount	Consult
88792	Power Supply, IDEC 12 VDC DIN Rail Mount, 1.3 Amp, Input: 85 to 264 VAC, 100 to 370 VDC 15W	\$1,300.00
119244	Power Supply, 24VDC 1.3 A Din Mount Input 90 to 264 VAC, 120 to 370 VDC, UL E135494	\$160.00

Optional HMI terminal with web server



BELT SCALES

SCT-4XD

Belt Scale Integrator

Dimensions

SCT-4XD			
A	10.50 in (267 mm)	C	13.12 in (333 mm)
B	8.00 in (203 mm)	D	12.50 in (318 mm)
E	6.26 in (159 mm)		

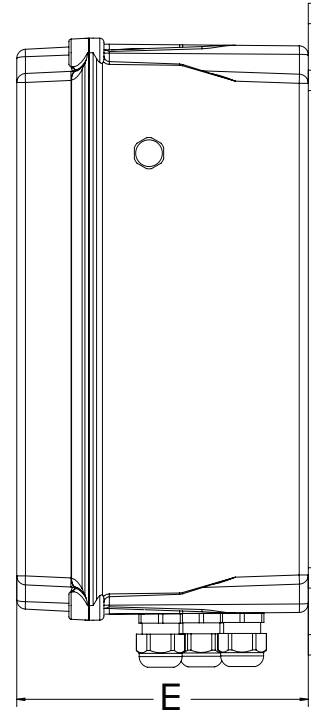
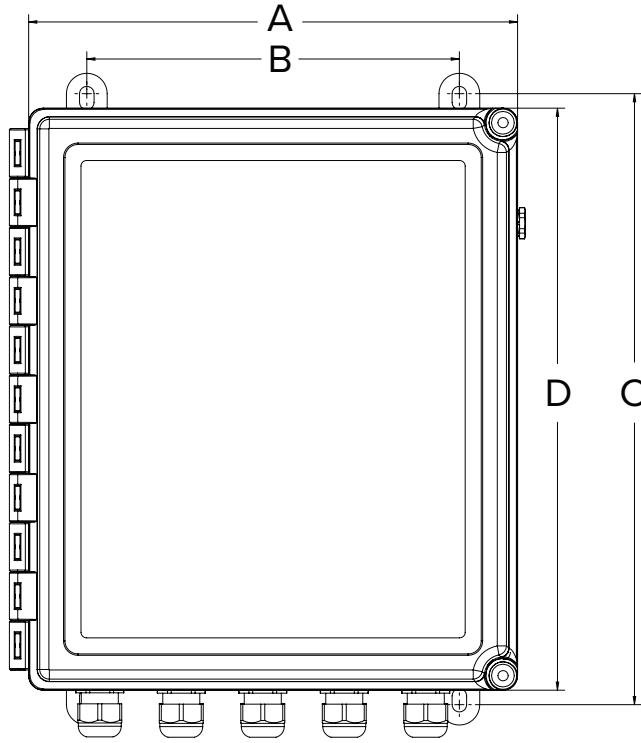



High-resolution Speed Sensor



Magnetic Coupler



Speed Wheel



Speed Sensors 125334 and 163319

Standard Features

- The speed sensor monitors belt speed. It is directly coupled to a rotating shaft which drives a signal generator. The speed sensor submits an output signal at a frequency directly proportional to the shaft speed. It is typically installed on a non-driven pulley of a belt conveyor for detecting belt speed.

Part Number/Price

Part #	Description	Price
Speed Sensing		
152626	500 PPR high-resolution encoder kit, requires 152247 if magnetic coupling is required	\$1,600.00
152247	Magnetic coupler, use with 152626	\$500.00
125334	Speed sensor, belt scale 50 PPR (generator type)	\$1,200.00
163319	Speed sensor, belt scale 600 PPR (encoder type)	\$1,200.00
94969	Speed wheel assembly, 10 PPR NPN Configuration	\$1,000.00
Static Weights		
99708	15 lb weight	\$215.00
99709	30 lb weight	\$275.00
99696	3 in static weight mounting bracket (set of two)	\$535.00
99922	4 in static weight mounting bracket (set of two)	\$600.00
Speed Sensor Replacement Parts		
94979	Sensor proximity, for 94969	\$115.00
98320	Shoulder bolt, for 94969	\$15.00
95216	Bushing, speed wheel for 94969	\$12.75
192927	Coupler, replacement for 125334 and 163319	\$175.00
Accessories		
97416	Kit, shim 50 each 1/16 in, 1/8 in and 1/4 in thick	\$95.00
21161	Junction box, splice single cell	\$80.00
98501	Cable, load cell custom, 20 ft EL146HE	\$34.50

Idle hardware not included with weigh frames

Belt Scale Application



Company: _____ Prepared By: _____ Date: _____

Address: _____

City: _____ State/Zip/Country: _____

Phone: _____ Fax: _____ Email: _____

Application Notes:

MATERIAL

Material being measured: _____ Bulk Density (kg/l) (lb/cu. ft) _____
Corrosive state of material (choose one): High Moderate Not Corrosive
Feed Rate t/hr: _____ min. _____ max. Accuracy Required: +/- _____ %
Constant Feed Rate: Yes No

CONVEYOR

Application: Inventory Load out Control Blending
Profile: Horizontal Incline/decline _____ (deg) Variable Incline _____ (deg) Curved
Automatic Tensioning Apparatus: Yes No
Access Side (looking in direction of belt travel): Left Right Both
Area Classification: Zone _____ Class _____ Division _____
Does the current conveyor have scale grade idlers: Yes No
Belt Speed (ft/m per minute): _____ min. _____ max.
Condition of belt: _____
What type of splice does the belt have: _____
Belt Length: _____ m/ft Belt Width: _____ mm/in Belt Cleaning Device: Yes No
Idler Diameter: _____ mm/in Idler Spacing: _____ mm/in Tail Pulley Diameter: _____ mm/in
Trough Angle: _____ degrees Conveyor Length: _____ ft/m
(Supply sketch where possible) Sketch attached

INTEGRATOR REQUIREMENTS

Enclosure Type: Field Mount/Universal Panel Mount Wall Mount
Power Available: 115V 230V 9-36VDC
Communications: AB Remote I/O Device Net Profibus-DP Ethernet IP
 Analog Output RS-232 (standard) Ethernet TCP/IP Control Net
Remote Display Rate: Yes No Remote Display Totalizer: Yes No
Speed Sensor: Speed Wheel Shaft Encoder Magnet

Belt Scale Application

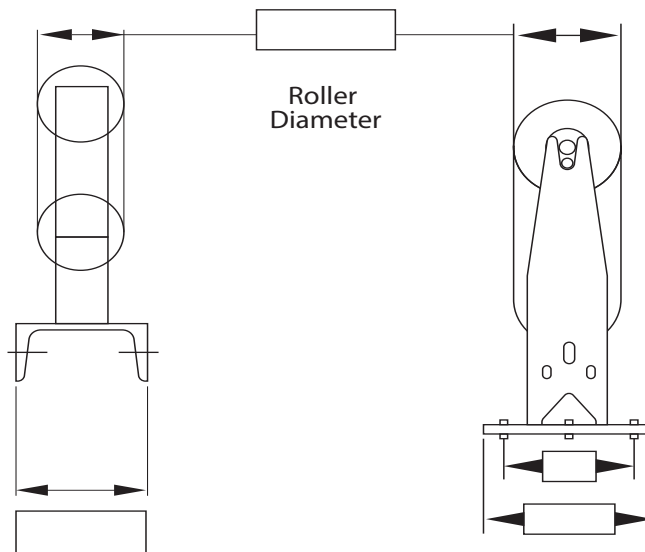
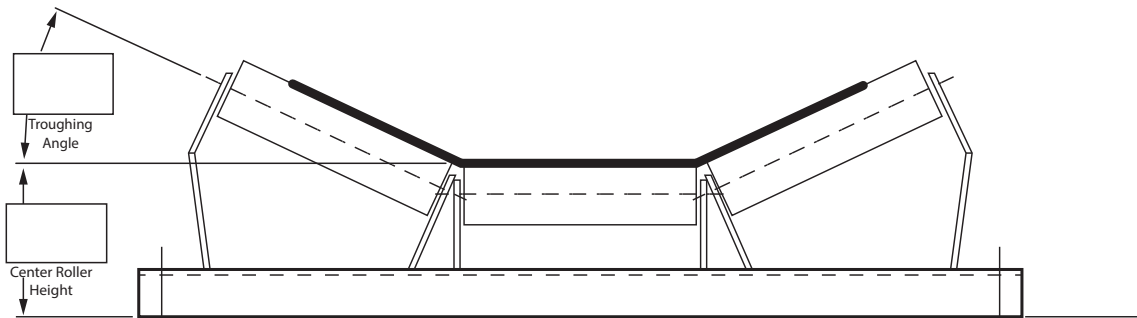
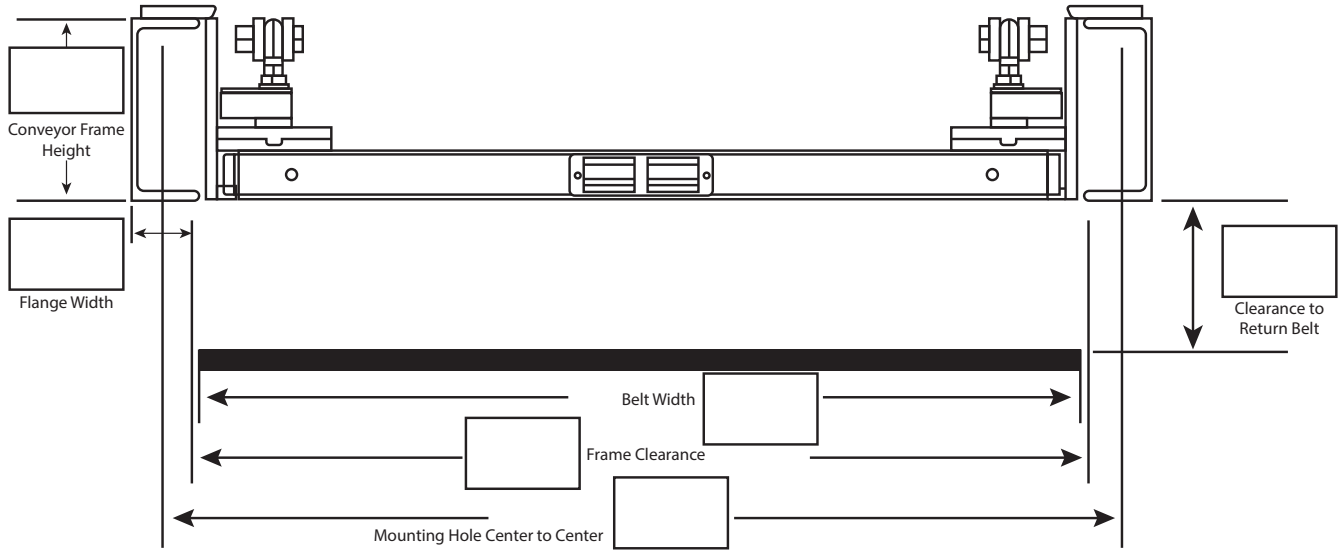

Large empty grid area for data entry.