

MSI-3460 Challenger Crane Scale

Retrofit Kit Installation Instructions

The MSI-3460 Challenger Crane Scale Retrofit Kit updates older generations of the MSI-3460 Port-A-Weigh Crane Scales to the most current configuration of the MSI-3460. The MSI-3460 Challenger Crane Scale Retrofit Kit is available with or without a Digi XBee-PRO[®] radio module. Generation information is located on the serial tag.



Manuals are available from Rice Lake Weighing Systems at www.ricelake.com/manuals

Warranty information is available at www.ricelake.com/warranties

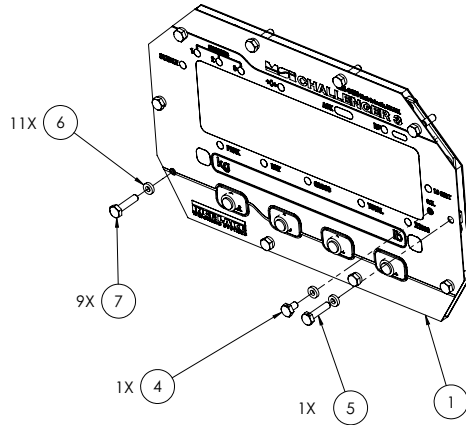

Figure 1. MSI-3460 Retrofit Kit Parts Diagram

Item No.	Part No.	Description	Qty
1	211079	Front Panel Assy Challenger3 XBEE Dual Color 4-16V 3460C (PN 222747)	1
	211078	Front Panel Assy Challenger3 No-RF Dual Color 4-16V 3460C (PN 222746)	
2	139398	Load Cell Cable Adapter 3460 Retrofit	1
3	144292	Splice Butt 26-22 AWG Insulated	4
4	142574	Screw HH DR HD SS Blk 6-32 1/4	1
5	142573	Screw Mach HH Drilled HD SS Blk 6-32 5/8	1
6	144645	Washer Rubber #6 .120ID x .250D x .062 THK	11
7	142276	Screw Mach HH SS BLK 6-32 5/8	9

Table 1. MSI-3460 Retrofit Kit Parts List



NOTE: Items 2 and 3 are bagged separately and shipped with the unit.

2.0 Rewiring the Unit

Retrofit wiring requirements vary depending on generation.

Rewiring from a MSI-3360

1. Locate the cable attached to the load cell.
2. Cut the connector off as close to the connector as possible.
3. Using butt splices (3), splice on load cell cable adapter (2). Match wire colors
4. Connect the load cell adapter (2) to P2 on the printed circuit board assembly (PCBA).
5. Connect the power cable to P5 of the PCBA.

Rewiring from a MSI-3460

1. Connect the load cell cable to P2 of the PCBA.
2. Connect the power cable to P6 of the PCBA.

3.0 Reassembling the Unit

1. Place the front panel assembly and gasket on the scale casting and secure with the supplied screws and washers.
2. Torque screws to 1.75 in-lbs in the order shown in [Figure 2 on page 2](#).
3. Calibrate the unit. (See the MSI-3460 Technical Manual for the calibration procedure.)



© Rice Lake Weighing Systems Content subject to change without notice.

230 W. Coleman St. • Rice Lake, WI 54868 • USA USA: 800-472-6703 • International: +1-715-234-9171