

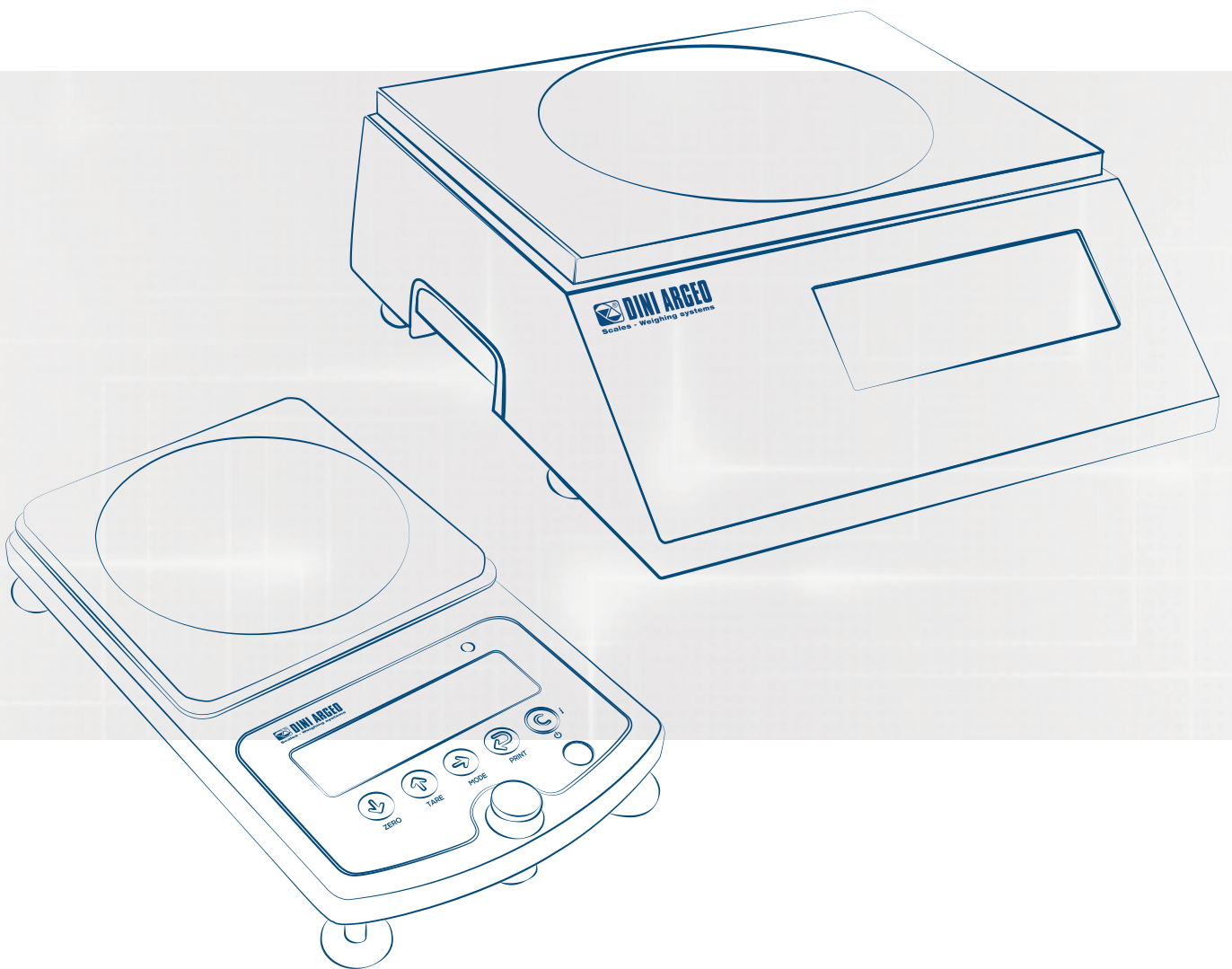

# WLB - KSD

User manual - 1.0\_R1





 **INDEX**

<b>Introduction</b> .....	<b>4</b>
<b>Warnings</b> .....	<b>4</b>
<b>Main features</b> .....	<b>5</b>
Power supply via mains .....	6
Power supply via battery .....	6
Integrated thermal printer.....	6
Customisable printouts.....	7
Automatic reset when scale is switched on.....	7
Keyboard lock.....	7
Saving battery power.....	8
Automatic switching off .....	8
Available tare functions.....	8
Remote control .....	9
The display.....	10
<b>Basic scale functions</b> .....	<b>11</b>
On / Off.....	12
Zero .....	12
Automatic tare.....	13
Tare deletion .....	13
Presettable tare (PT) .....	14
Print .....	15
Metrics.....	15
<b>Specific scale functions</b> .....	<b>16</b>
How to access the function menu .....	17
Available functions.....	17
High resolution weighing ( <i>hi RES</i> ).....	18
Accumulation ( <i>totRL</i> ) .....	20
Mixing several components ( <i>ForFUL</i> ) .....	22
Piece counting ( <i>Count</i> ).....	24
Weight check ( <i>ChECK</i> ) .....	26
Unit of measurement conversion ( <i>ConUER</i> ).....	29
Percentage weighing ( <i>PERC</i> ) .....	30
Holding weight on the display ( <i>hold</i> ).....	33
Net/gross weight display ( <i>Net.Gro</i> ) .....	34
 <b>Configuration menu</b> .....	<b>35</b>
How to access the configuration menu .....	35
Date and time ( <i>CLoCF</i> ).....	36
High resolution reading division ( <i>PREC . ID</i> ) .....	36
Alibi memory reading ( <i>RL ib i</i> ).....	37
Relay port ( <i>SEtPnt</i> ).....	37
Weighing filters ( <i>FiLTER</i> ) .....	38
Display backlighting ( <i>SErEEr</i> ).....	39
Tare ( <i>tARrE</i> ).....	40
Automatic switching off ( <i>AutOFF</i> ) .....	40
Manual printer switching on ( <i>on.Pr in</i> ) .....	40
Ticket number reset ( <i>t iR . rES</i> ) .....	41
Factory configuration reset ( <i>rESEt</i> ) .....	41
Diagnostics ( <i>d iRG</i> ) .....	41
<b>FAQ - Frequently Asked Questions</b> .....	<b>42</b>
Print .....	43
Accumulation.....	43
Tare.....	43
Weighing .....	44
Piece counter.....	44
<b>Error messages</b> .....	<b>45</b>



## INTRODUCTION

---

The purpose of this manual is to familiarise the user with the different weight indicator operating modes, key functions and display instructions.

**We recommend carefully following the instructions when programming the weight indicator, as to do otherwise could jeopardise proper scale operation.**

In addition to having all the conventional features of a high precision scale, the indicator offers extra user features such as the function of converting the unit of measurement into pounds, converting net weight/gross weight, gross weight or net weight setpoint, in-out truck weighing, single scale universal repeater, multi-scale repeater, approved weight transmission to PC with alibi memory, +/- checkweighing, sample weight percentage, weight hold on display, peak sensor, weighing accumulator, piece counting.

These features make it suitable both for industrial use as well as for legal use with third parties and in trade, meeting the most up to date needs as far as transmission and data printing via the two bidirectional serial ports.

This manual was written with the utmost care but we always welcome feedback on any inaccuracies you may find.

## WARNINGS

---

The instrument is covered by warranty and **MUST NOT BE OPENED BY THE USER** for any reason. Any attempt to repair or modify the unit could expose the user to the risk of electrical shock and will render all warranty conditions null.

All problems with the unit or the system must be communicated to the manufacturer or the dealer from which it was purchased. In any case, **DISCONNECT POWER** before any operations.

The instrument is insulated between the dangerous voltage area and the parts that are accessible to the user.

- Do not pour liquids onto the indicator.
- Do not use solvents to clean the indicator.
- Do not expose the instrument to direct sunlight or sources of heat.
- Set or secure the indicator and the platform on a base with no vibrations.
- All the indicator connections must be made respecting the applicable standards in the installation area and environment.

Whatever is not explicitly described in this manual is to be considered improper use of the equipment.

**Do not install in atmospheres with the risk of explosion.**

The crossed out wheellie bin symbol on the product shows that it must be brought to appropriate separate waste collection centres at the end of its life cycle or returned to the dealer when purchasing a new equivalent product. Proper separate collection to then send the product to recycling contributes to preventing possible negative effects on the environment and to health and promotes recycling. Users who dispose of the product illegally shall face administrative sanctions as provided for by law.





# MAIN FEATURES

## of the scale

Power supply via mains .....	6
Power supply via battery .....	6
Integrated thermal printer .....	6
Customisable printouts.....	7
Automatic reset when scale is switched on.....	7
Keyboard lock.....	7
Saving battery power.....	8
Automatic switching off .....	8
Available tare functions .....	8
Remote control .....	9
The display.....	10



## POWER SUPPLY VIA MAINS

Every DFW range indicator is equipped with a specific power cable or charger, depending on the model. The only exceptions are the specific models for explosive atmospheres, in which case refer to the specific manual. The safety standards in force must be respected when connecting the unit to the 110/240V mains, including the use of a "clean" line with no disturbances or interferences caused by other electronic equipment. The power-on LED (if available) on the front panel comes on if the instrument is powered correctly. If there is an internal rechargeable battery, it is charged automatically.

## POWER SUPPLY VIA BATTERY

### Internal battery charge level indicator



Charged battery



Low battery

The **LoB.bAtt** message precedes automatic instrument switching off.

### Battery charging indicator



## INTEGRATED THERMAL PRINTER

The printer is usually in STAND-BY and is only powered by the weight indicator when it is time to print in order to ensure the battery holds its charge longer. Once printing is complete, the printer automatically goes back into STAND-BY.

### How to manually switch on the printer

Go into the configuration menu and enable the **on.Pr in** function (see page 35)

### How to replace the roll

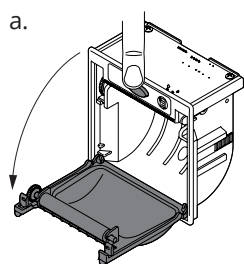

a. Open the door by pressing the centre button.

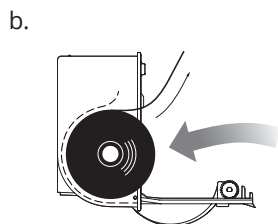

b. Put the roll in, keeping the thermal surface facing outward.

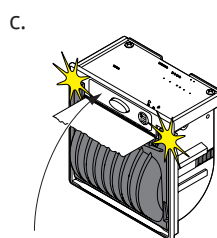

c. Close the door by pressing on both sides.

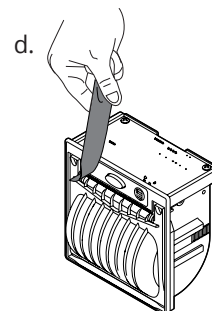

d. Remove the excess paper.



## CUSTOMISABLE PRINTOUTS

If the instrument is equipped with a printer, the ticket or label can be customised as shown in the following example.

*Customising printouts requires advanced configuration.*

### Example of ticket/label

MARIO ROSSI SRL VIA DELL'INDUSTRIA, 20 41042 - FIORANO (MO) - ITALY WWW.MARIOROSSI.IT		Heading
WEIGHING NR. 1		Progressive weighing number (for accumulation modes)
GROSS 15.000 kg TARE 3.000 kg NET 12.000 kg		Weight data
TICKET NR. 54321		Progressive ticket number
09/05/06 15:39:03		Date and time
		Bar code 39

### Example of packing list

MARIO ROSSI SRL VIA DELL'INDUSTRIA, 20 41042 - FIORANO (MO) - ITALY WWW.MARIOROSSI.IT	
WEIGHING NR. 00000001 NET 1.000 kg	
WEIGHING NR. 00000002 NET 1.000 kg	
WEIGHING NR. 00000003 NET 1.000 kg	
WEIGHING NR. 00000004 NET 1.000 kg	
WEIGHS TOTAL 00000004 TOTAL NET 4.000 kg TICKET NR. 12345 09/05/06 15:39:03	

## AUTOMATIC RESET WHEN SCALE IS SWITCHED ON

If a weight less than 10% of the capacity is on the scale when it is switched on, the weight is automatically reset.

This function is useful in automatically resetting a container, pallet or small structure without having to recalibrate the scale.

*Weights over 10% can be reset by changing the original calibration.  
Automatic reset when the scale is switched on can be deactivated.*

*Automatic reset when the scale is switched on requires advanced configuration.*

## KEYBOARD LOCK

The indicator keyboard can be deactivated in order to avoid accidentally carrying out the available functions.

*Keyboard lock requires advanced configuration.*



## SAVING BATTERY POWER

---

The instrument is equipped with advanced battery power saving functions designed to increase operating time.

 *Saving battery power requires advanced configuration.*

## AUTOMATIC SWITCHING OFF

---

This function activates when the scale is completely unloaded and has not been used for a set amount of time (*standard 5 minutes*). To activate or deactivate automatic switching off, go into the autoff section in the configuration menu (*see page 35*)

### WARNING

In accumulation and formulation mode, automatic switching off causes the accumulation in progress to be lost.

## AVAILABLE TARE FUNCTIONS

---

The instrument allows you to choose from specific tare functions for your needs:

- "Locked" tare (standard factory configuration).
- "Unlocked" tare: automatically deleted every time the scale is unloaded. Useful in preventing errors when the tare is different for every weighing.
- Tare acquired automatically by the scale. Tare is only acquired if there is no other saved tare value.
- Tare function disabled.

To customise the tare function, go into the *LR-E* section in the configuration menu (*see page 35*)



## REMOTE CONTROL

The instrument can be equipped with an infrared or radio frequency remote control.

### Remote control functions

KEYBOARD	FUNCTION		
	TARE MODE	MULTI-FUNCTION	
		SHORT	LONG
<b>ZERO</b>	TARE	Zero	-
<b>TARE</b>	TARE	Tare	Manual tare (PT)
<b>MODE</b>	TARE	Operating mode	-
<b>PRINT</b>	TARE	Print	-
<b>C</b>	TARE	Cancel/Delete	Stand-by/Switch-on
<b>NUMERICAL KEYS</b>	TARE	-	-
<b>F1</b>	TARE	-	-
<b>F2</b>	TARE	-	-
<b>F3</b>	TARE	-	-

*The remote control requires advanced configuration.*

### Additional radio frequency remote control configurations

#### Multi-remote control

Useful when several operators are using the same scale (up to 3).

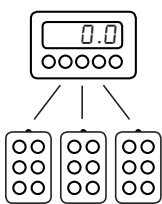

#### Broadcast

Useful when you need to command several scales with the same remote control.

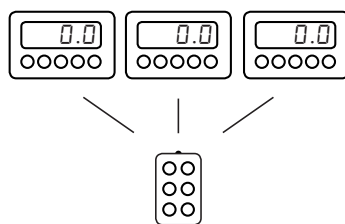

#### Ad hoc

Useful when there are several scales installed in the same area, each managed by its own remote control.

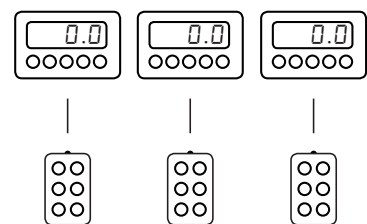



## THE DISPLAY

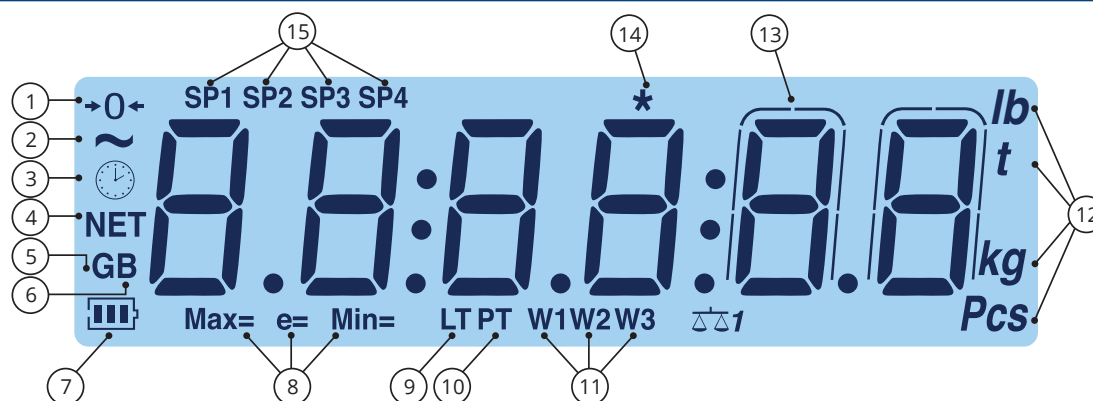

Number	Symbol	Description
(1)	→0←	The scale is unloaded and at zero (gross).
(2)	~	The weight is unstable.
(3)		The time is being shown on the display.
(4)	<b>NET</b>	The weight displayed is net. There is a saved tare.
(5,6)	<b>G B</b>	The weight displayed is gross.
(7)		Battery level.
(8)	<b>Max=</b> <b>Min=</b> <b>e=</b>	Metrics are being displayed.
(9)	<b>LT</b>	A locked tare is active.
(10)	<b>PT</b>	A manual tare is active.
(11)	<b>W1 W2 W3</b>	Indicate the range of active weighing.
(12)	<b>lb ... Pcs</b>	Units of measurement - Pounds (lb), tonnes (t), kilograms (kg), grams (g), number of pieces (Pcs).
(13)		The weight is being displayed in high resolution.
(14)	<b>*</b>	Indicates a key is pressed. In some operating modes, it indicates that a specific function is active.
(15)	<b>SP1... SP4</b>	Indicate the active relay ports (only with the optional board).

LETTERS:

A	B	C	D	E	F	G	H	I	J	K	L	M	N	O	P	Q	R	S	T	U	V	W	X	Y	Z
a	b	c	d	e	f	g	h	i	j	k	l	m	n	o	p	q	r	s	t	u	v	w	x	y	z

NUMBERS:

0	1	2	3	4	5	6	7	8	9
0	1	2	3	4	5	6	7	8	9



# BASIC FUNCTIONS

## of the scale

On .....	12
Off .....	12
Zero .....	12
Automatic tare.....	13
Tare deletion .....	13
Presetable tare (PT).....	14
Print .....	15
Metrics .....	15



## ON

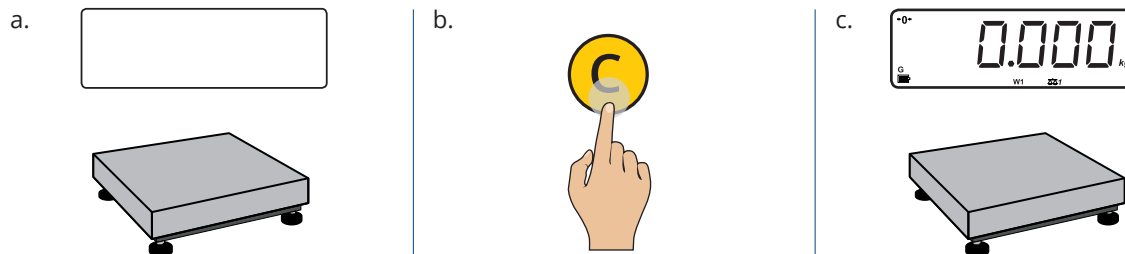

## OFF

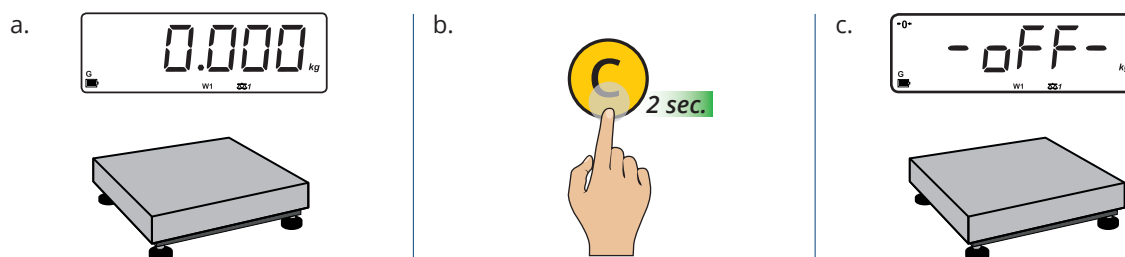

## ZERO

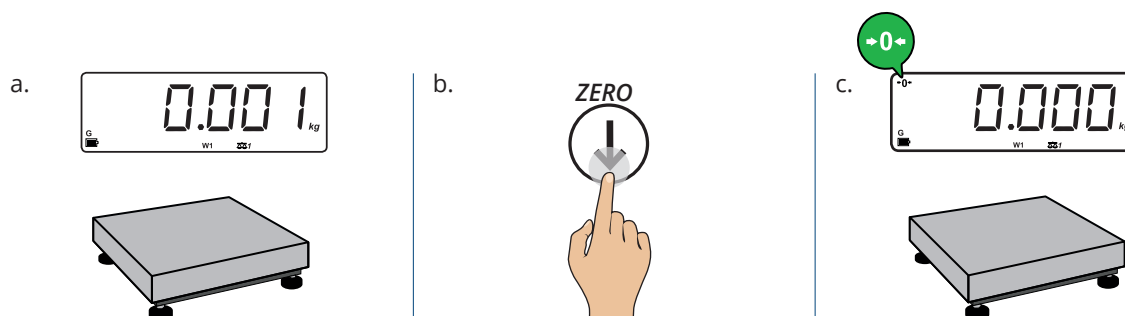



## AUTOMATIC TARE

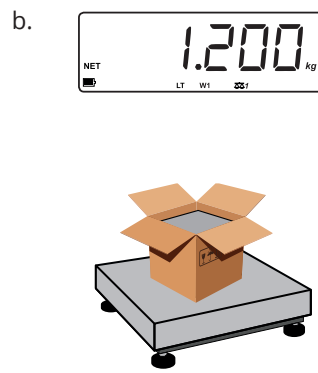
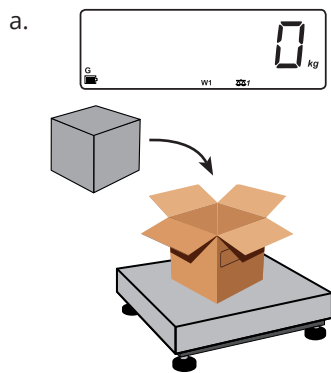
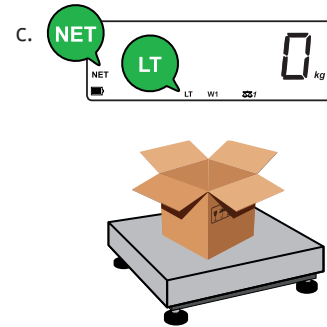
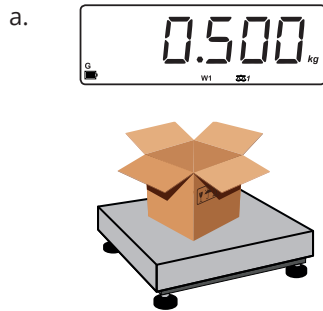

## TARE DELETION

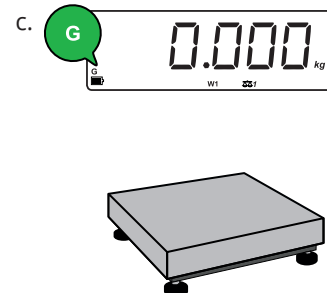
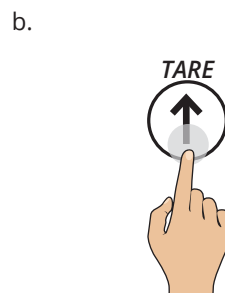
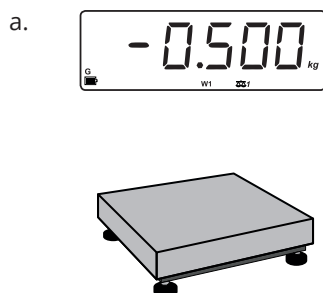



## PRESETTABLE TARE (PT)

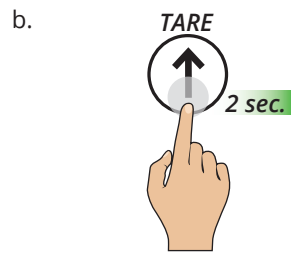
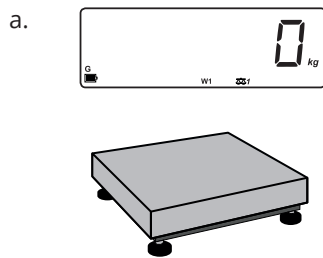

Setting the tare value

How to set the value

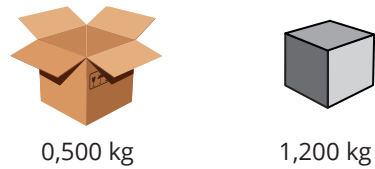
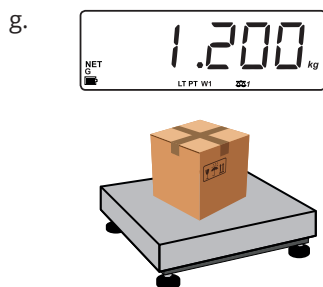
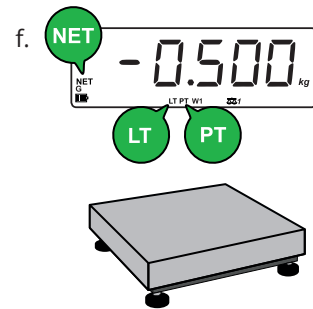
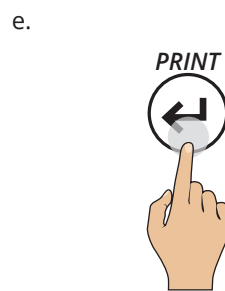



## PRINT

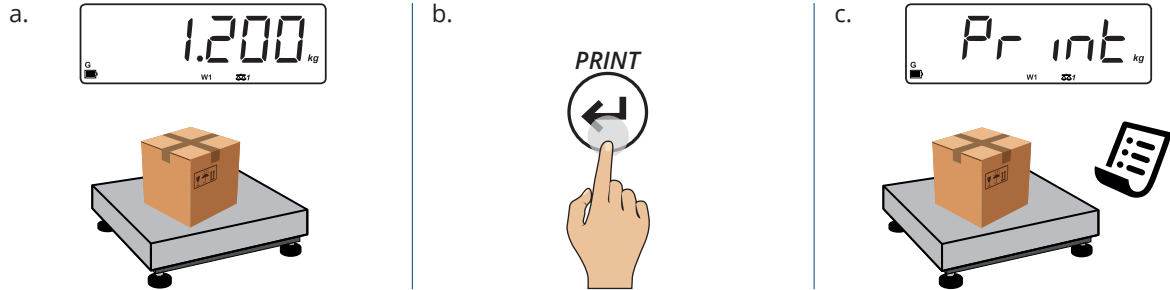

## METRICS

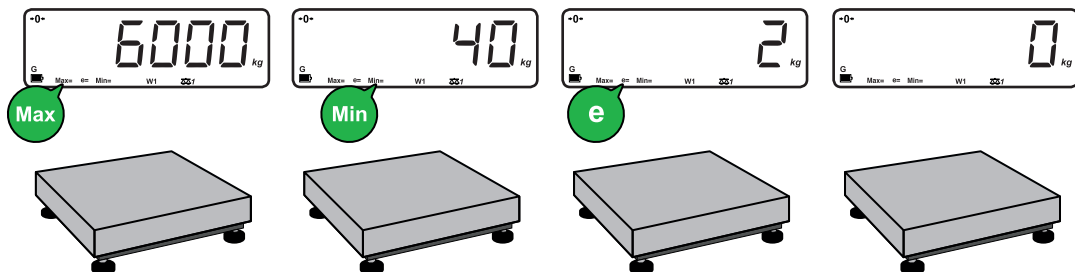
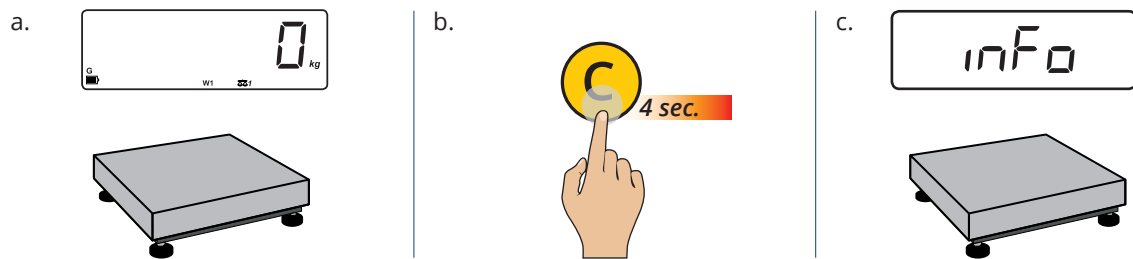



# ADVANCED FUNCTIONS

## of the scale

How to access the function menu .....	17
Available functions.....	17
High resolution weighing ( <i>HIGH RES</i> ).....	18
Accumulation ( <i>TOTAL</i> ) .....	20
Mixing several components ( <i>MIX</i> ) .....	22
Piece counting ( <i>COUNT</i> ).....	24
Weight check ( <i>CHECK</i> ) .....	26
Unit of measurement conversion ( <i>CONVERT</i> ).....	29
Percentage weighing ( <i>PERC</i> ).....	30
Holding weight on the display ( <i>HOLD</i> ).....	33
Net/gross weight display ( <i>NET GROSS</i> ) .....	34





## HOW TO ACCESS THE FUNCTION MENU

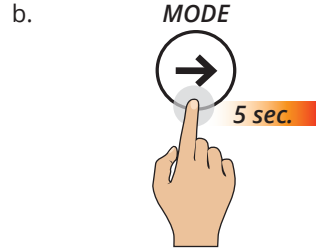
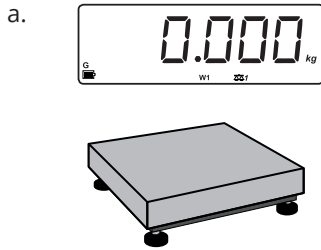

The indicator is in the function menu: the currently active function appears.

## AVAILABLE FUNCTIONS

- Weighing with high resolution display (for in-factory use)  
 See page 18
- Horizontal accumulation: sum of the weight of several objects to obtain the total weight  
 See page 20
- Vertical formulation or accumulation: mixing several components  
 See page 22
- Counting  
 See page 24
- Weight check compared to a reference sample.  
 See page 26
- Unit of measure conversion  
 See page 29
- Weighing in % compared to a reference sample  
 See page 30
- Holding weight on the display  
 See page 33
- Net weight - gross weight exchange  
 See page 34

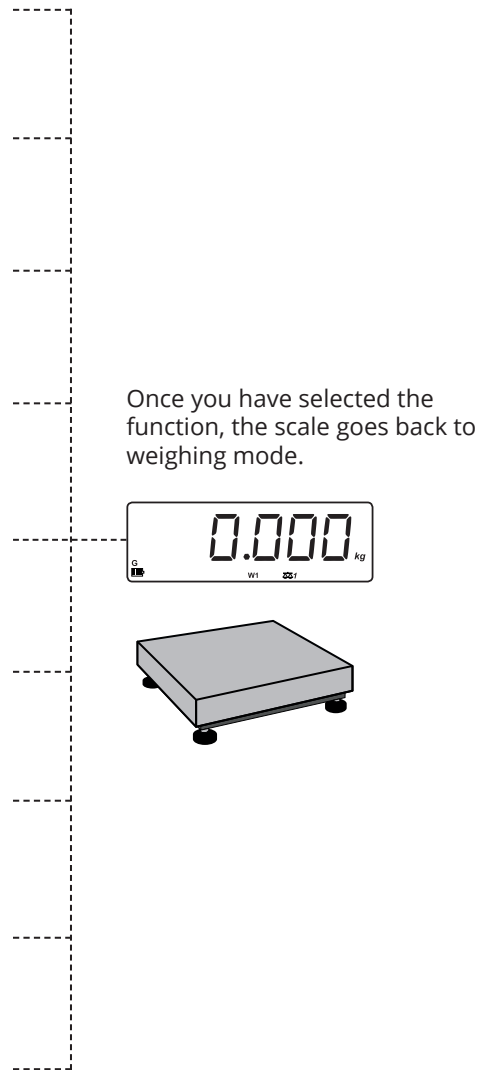



## WEIGHING WITH HIGH RESOLUTION DISPLAY - h.r.r.E5

### I. Check calibration

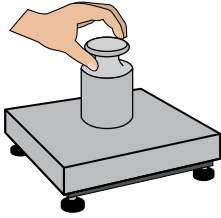

### II. Adjust calibration if necessary

a.

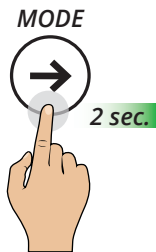

b.



Set the sample weight

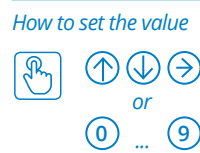

c.



d.



e.

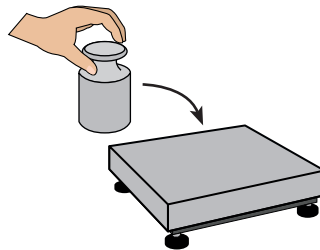

f.



g.

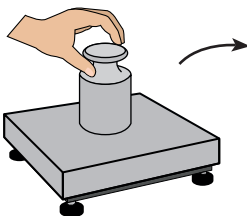

h.



i.



Check finished calibration



### III. Select the desired reading division

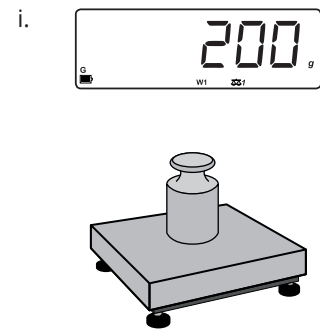
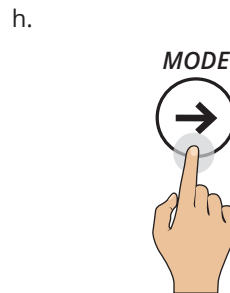
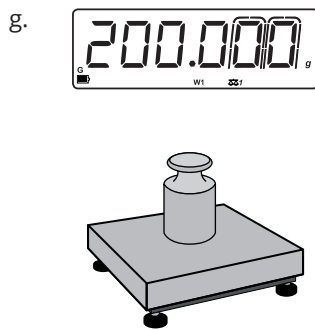
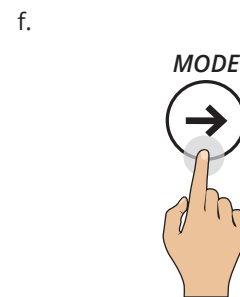
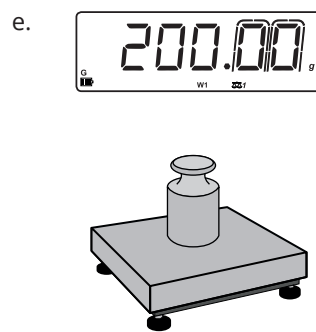
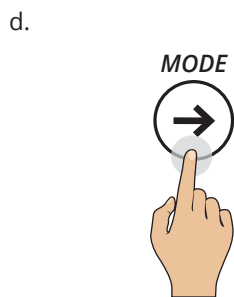
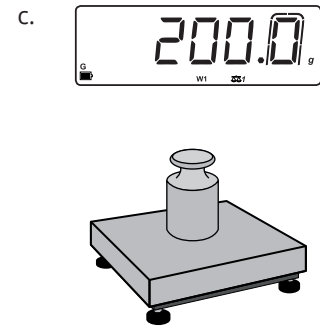
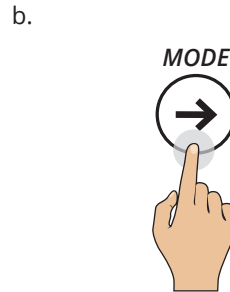
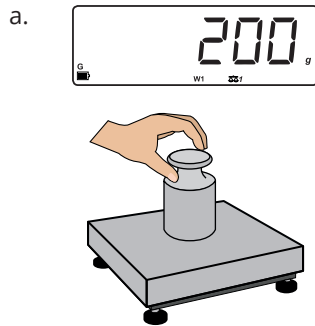

 This operating mode requires configuring an appropriate filter (h i . r E50...h i . r E57).  
(See page 35)



## HORIZONTAL ACCUMULATOR - totAL

### How to sum the weighs

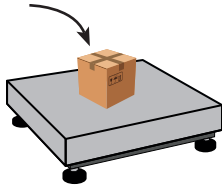

b.



c.

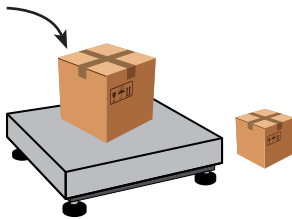
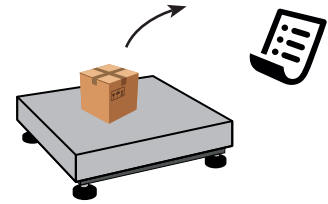

e.



f.

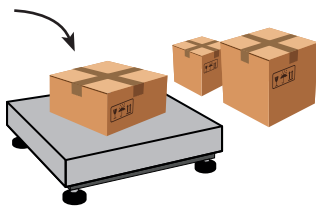
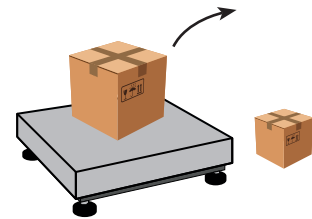

h.



i.

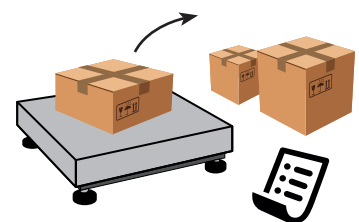



### How to momentarily read the total

a.



b.

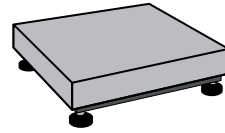

Number of weighs

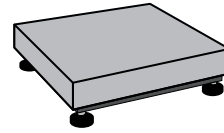

Total weight



### How to end accumulation and reset the total

a.



b.

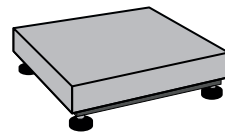
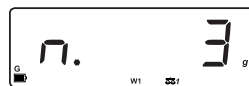

Number of weighs

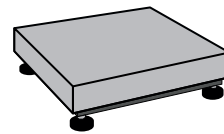

Total weight





## MIXING SEVERAL COMPONENTS - ForNuL

### How to sum the weighs

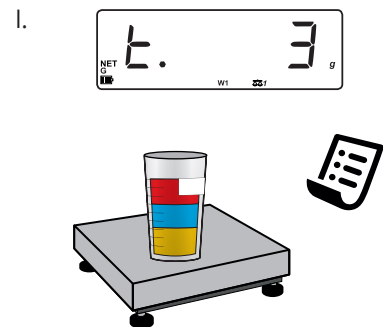
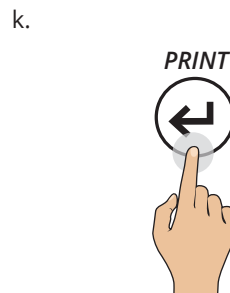
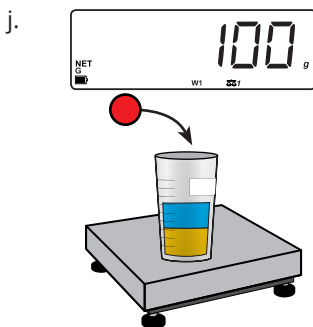
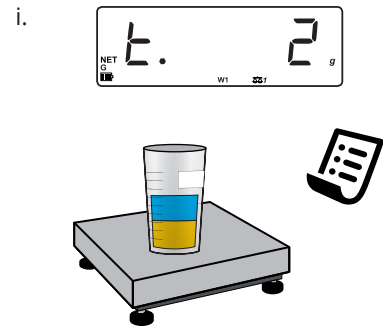
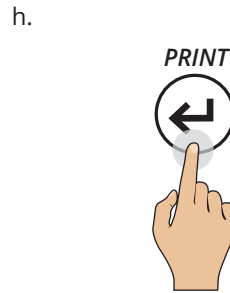
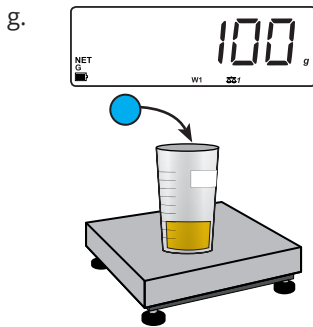
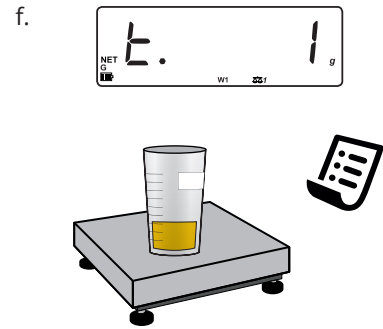
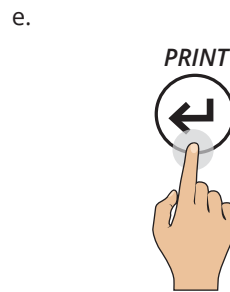
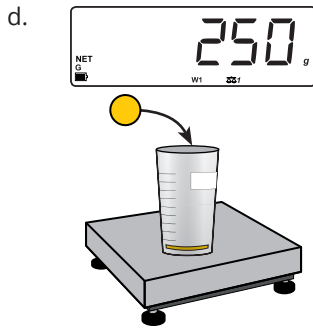
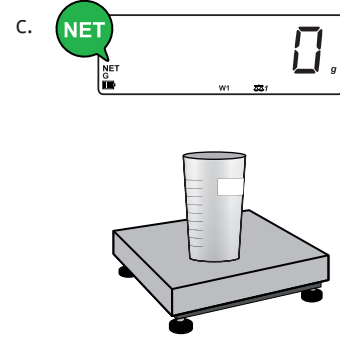
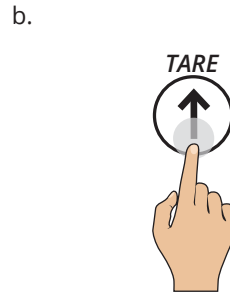
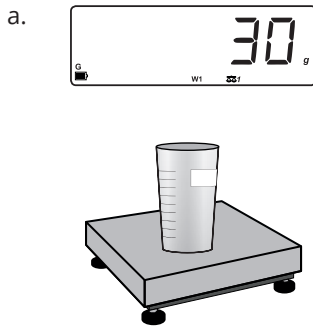



### How to read the total

a.



b.



...

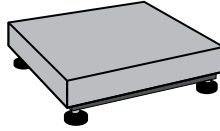

Number of weighs

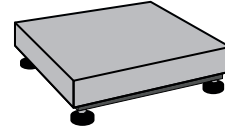

Total weight

### How to reset the total

a.



b.

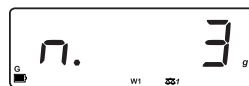

...

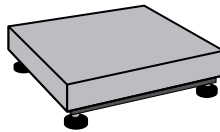

Number of weighs

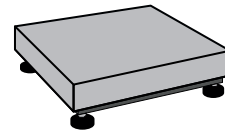

Total weight





# COUNTING - Count

## How to sample and count

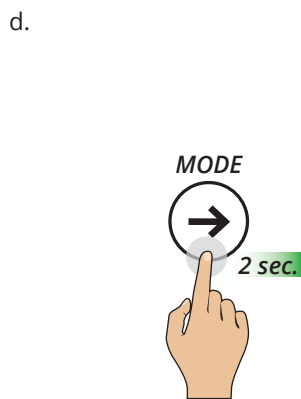
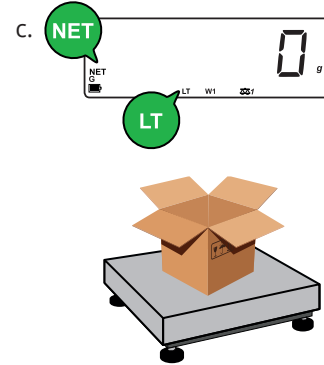
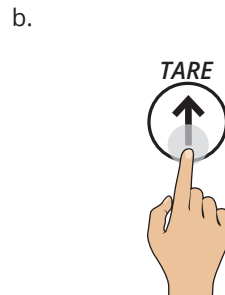
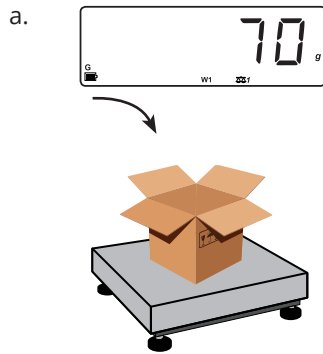

Select the desired reference quantity (5, 10, 20, ... 200 pieces)

How to set the value

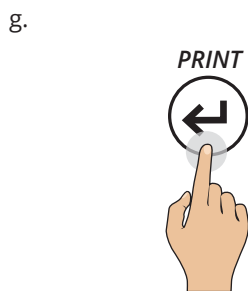
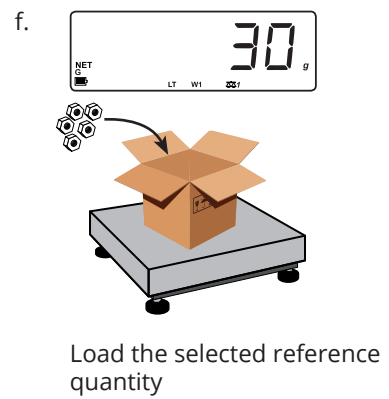

Sampling in progress, please wait...

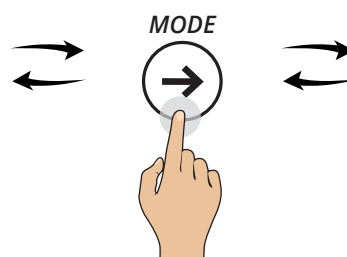
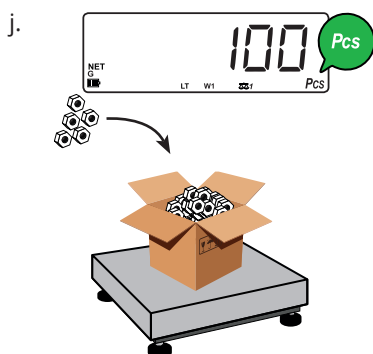
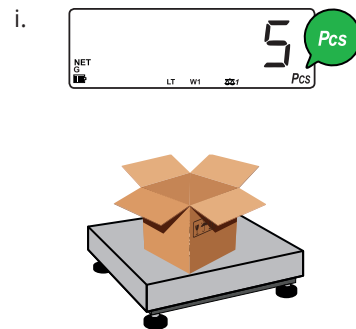

You can go from counting to weighing at any time

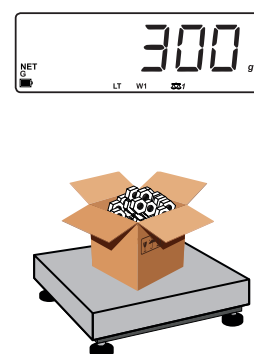





### How to enter the average unit weight (PMU)

a.



b.



c.



= 10,3427g

Enter the average unit weight

*How to set the value*



d.



e.

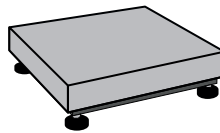

f.

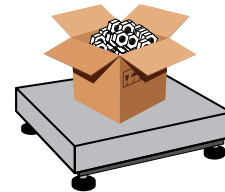

For correct counting, you must set the known tare value (see page 13) or tare the empty container and fill it with the pieces to count.



## WEIGHT CHECK - CHECK

### How to start the check with known reference weight

- a.
- b.
- c.
- d.   
*How to set the value*
- e.
- f.   
 Enter the lower tolerance  
*How to set the value*
- g.
- h.   
 Enter the higher tolerance  
*How to set the value*
- i.

#### Example 1

To check a weight of 1000 g with +/- 5 g tolerance (that is, between 995 g and 1005 g), set:

$\pm 0$  1000  
 L00005  
 h00005

#### Example 2

To check a weight of 500 g with + 10 g / - 20 g tolerance (that is, between 480 g and 510 g), set:

$\pm 00$  500  
 L00020  
 h00010



### How to start the check with automatic target acquisition

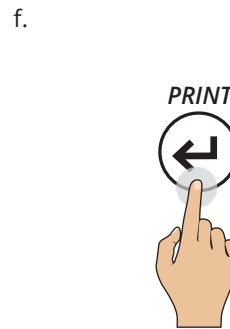
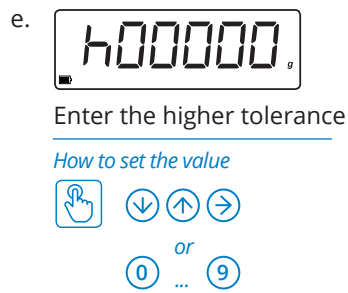
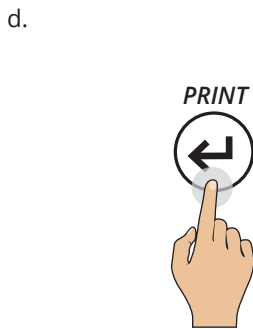
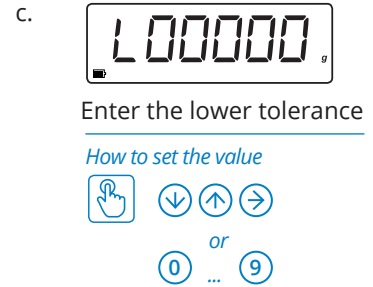
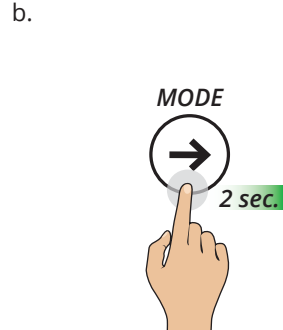
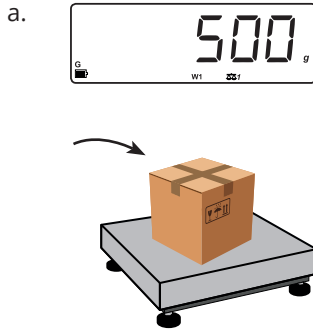

### How to check the weight

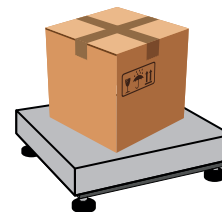
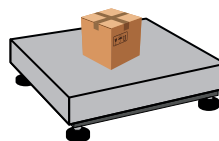
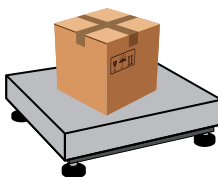



How to update the nominal weight with known reference weight

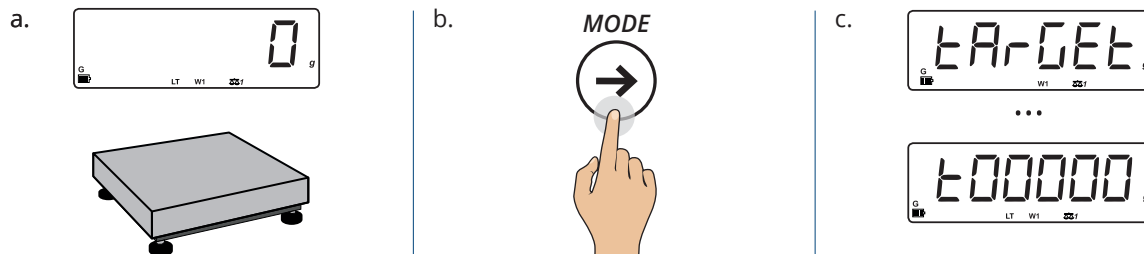

How to update the nominal weight with automatic target acquisition

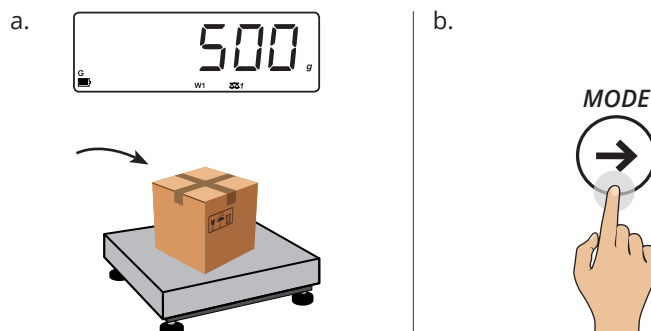

How to edit the check thresholds

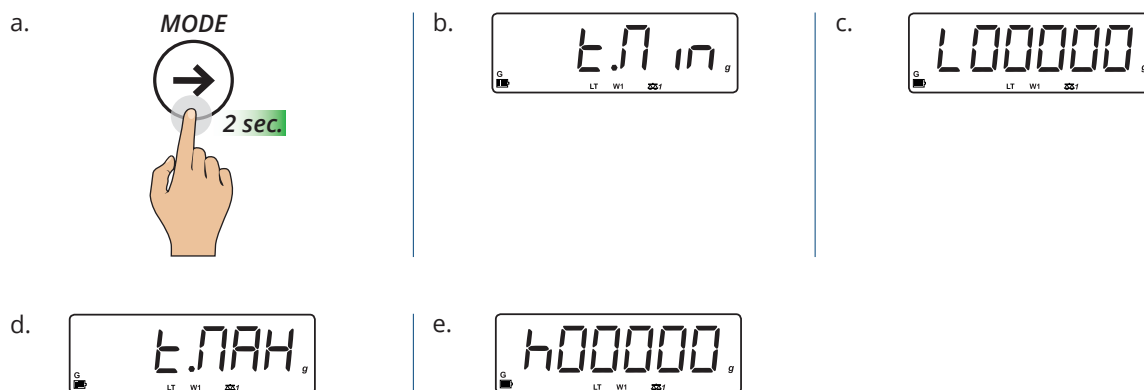



# UNIT OF MEASUREMENT CONVERSION - ConVEr



## How to convert the unit of measurement into pounds (standard mode)

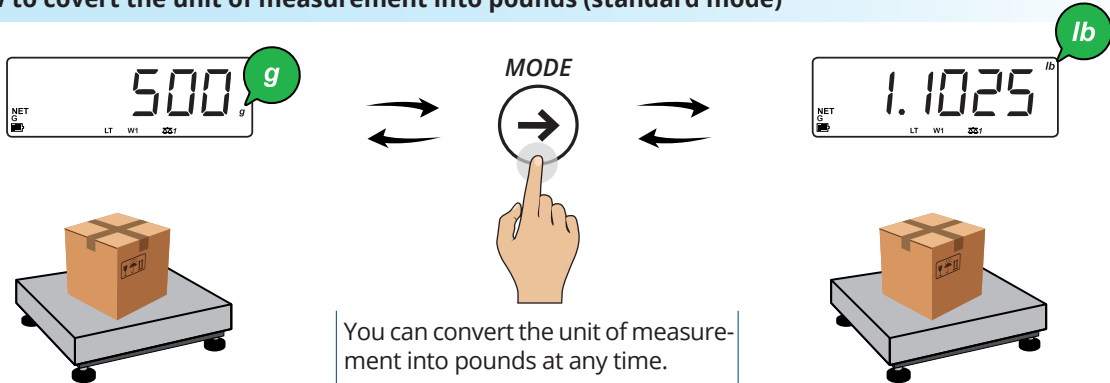

## Converting the unit of measurement with free conversion factor

a.

b.

c.

Pounds (lb)	1g = 0.0022
Ounces (oz)	1g = 0.0353
Stones (st)	1g = 0.0002
Karats (kt)	1g = 5
Grains (gr)	1g = 15.4324
...	

*i* Any conversion factor must be multiplied to the weight.

d.

Enter the average unit weight

How to set the value

or

...

e.

f.

You can convert the unit of measurement with free conversion factor at any time.



## PERCENTAGE WEIGHING - PERC

### Percentage check

#### I. How to acquire the 100% reference

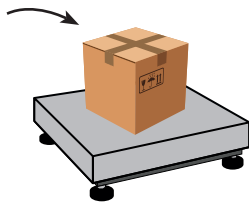

b.



c.



d.



e.

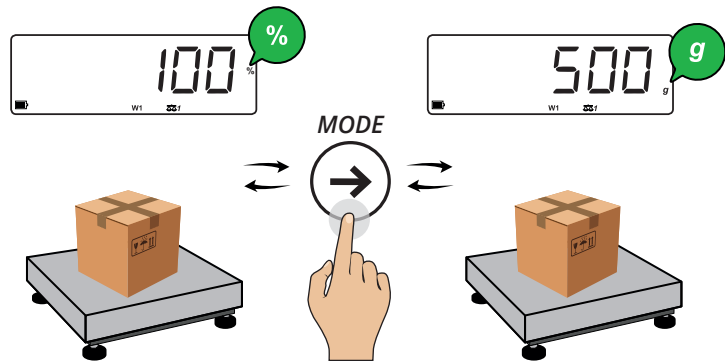

You can go from weight in percentage to weight in grams at any time.

#### II. How to check the weight

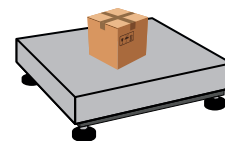
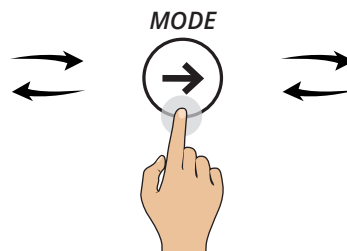
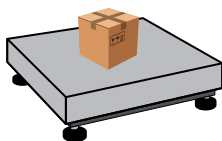
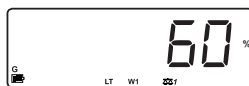

You can go from weight in % to weight in g. at any time.



### Percentage metering

Example of formula

**Product: RP28K**

- 1. 2127A3 - 50%
- 2. 23AB4 - 30%
- 3. Water - 20%

**Dose 500g**

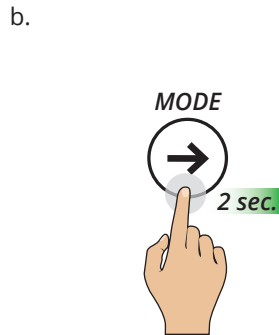
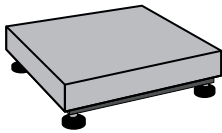

Enter the total quantity to achieve

*How to set the value*

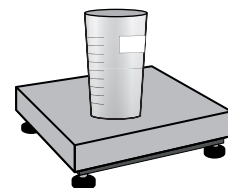
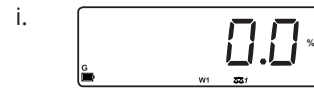
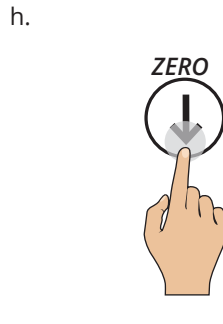
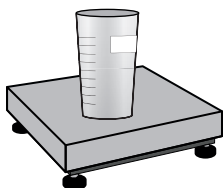
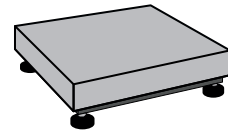
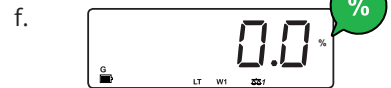
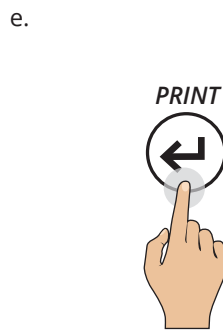
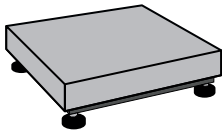

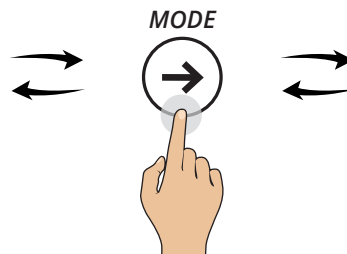
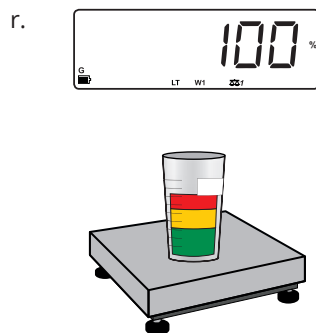
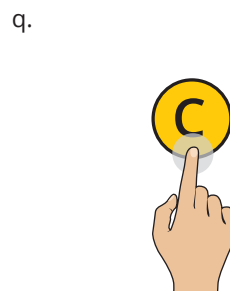
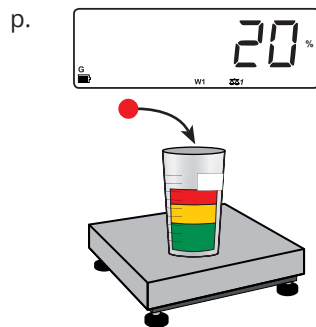
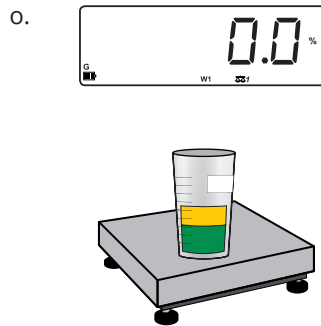
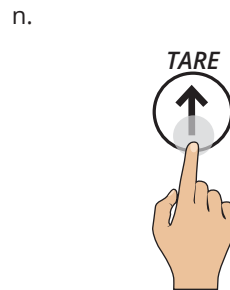
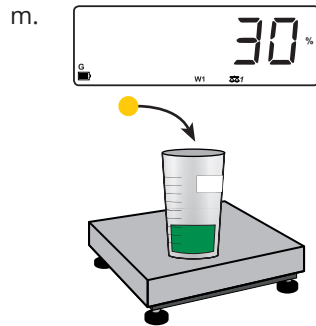
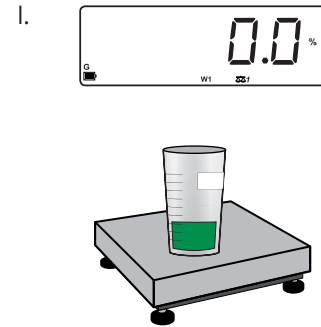
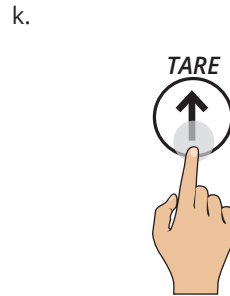
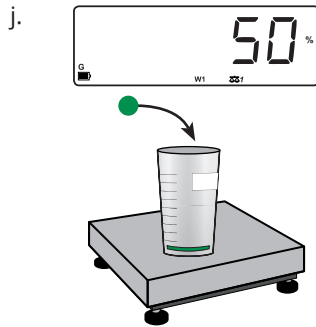

You can go from weight in % to weight in g. at any time.





## HOLDING WEIGHT ON THE DISPLAY - hold



### How to activate the function

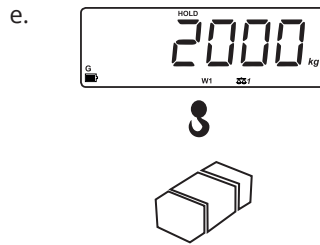
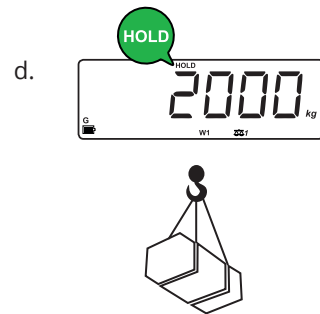
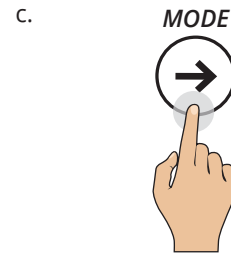
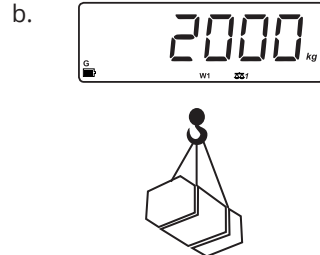
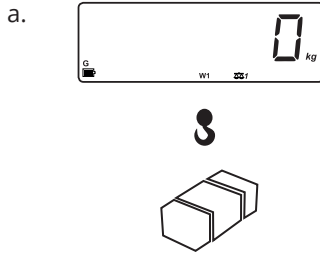

The weight on the display is held even when the scale is unloaded.

### How to deactivate the function

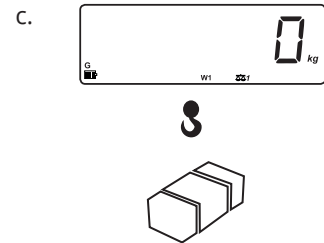
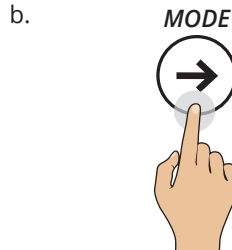
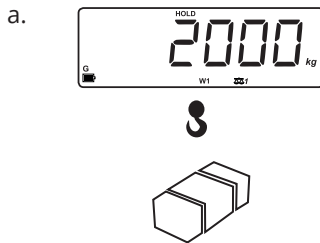



## EXCHANGE BETWEEN NET WEIGHT AND GROSS WEIGHT - *net.Gro*

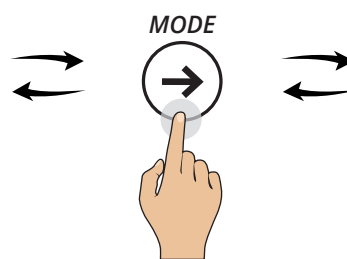
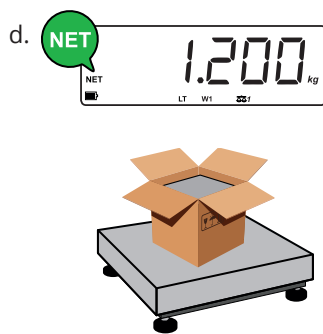
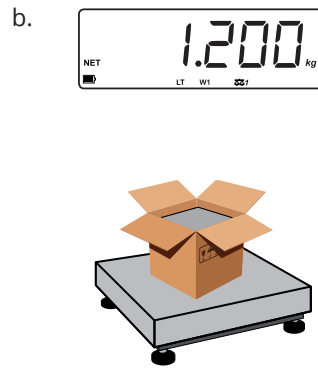
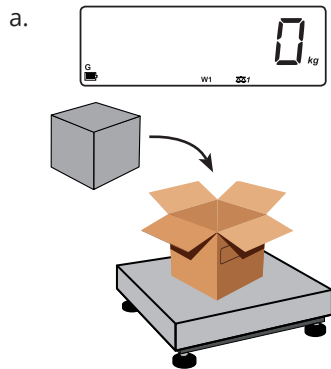
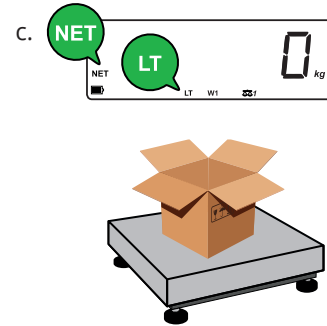
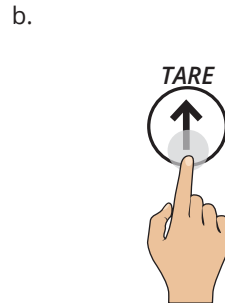
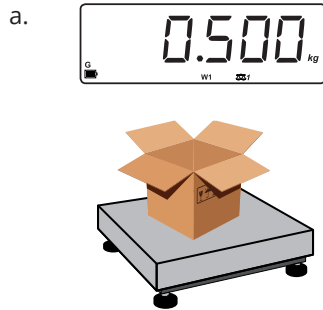

You can go from net weight to gross weight at any time.

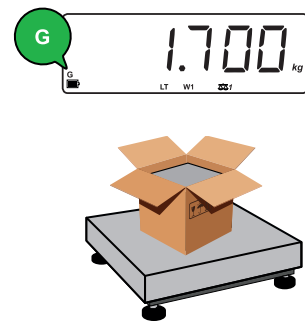



## **CONFIGURATION MENU** of the scale

How to access the configuration menu .....	35
Date and time (CLoCF).....	36
High resolution reading division (PREC . 10).....	36
Alibi memory reading (ALibi).....	37
Relay output (SEtPnt) .....	37
Weighing filters (F iLEr).....	38
Display backlighting (SCrEEr).....	39
Tare (tArE).....	40
Automatic switching off (AutOFF) .....	40
Manual printer switching on (on .Pr in) .....	40
Ticket number reset (t iN .rES) .....	41
Factory configuration reset (rESEt) .....	41
Diagnostics (d iAG) .....	41

### **HOW TO ACCESS THE CONFIGURATION MENU**

---

a.

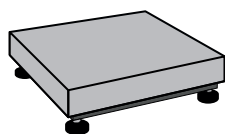

b.

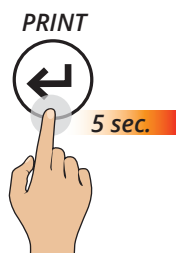









c.



The indicator is in the configuration menu.

How to enter  
1.  5 Sec.

How to browse  
 =   
 =   
 =   
 = 

 Page 35

- A **CLocK** →
- B **PrEC.10** 1 **DAY**
- C **ALib1** 2 **Month**
- D **SEtPnt** 3 **YEAr**
- E **FILtEr** 4 **hour**
- F **SCrEEr** 5 **MinutE**
- G **tArE**
- H **AutoFF**
- I **onPr in**
- J **t hRES**
- K **rESEt**
- L **d iAG**

 Visible only if the date/time option is available

Day

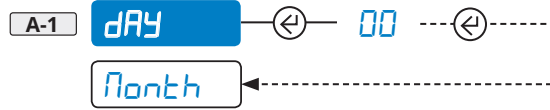

Month

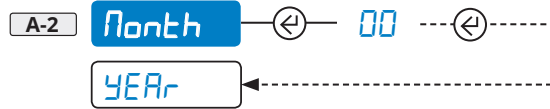

Year

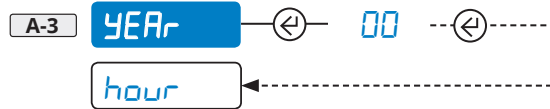

Hour

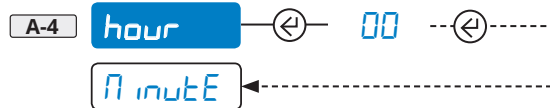

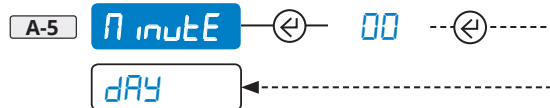

Minute



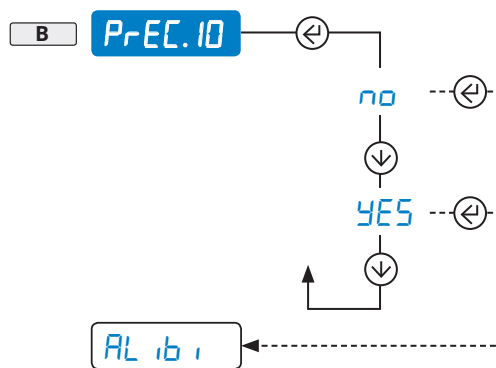









This functions allows you to display the weight with ten times greater resolution





How to enter  
1.  5 Sec.

How to browse  
↑ =   
↓ =   
→ =   
← = 

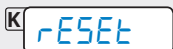
 Page 35

- A  CLocK
- B  PrEC.10
- C  ALibi
- D  SEtPnt
- E  FILTEr
- F  SCrEEr
- G  tArE
- H  AutOFF
- I  onPr in
- J  tArES
- K  rESEt
- L  d.AG



**ALibi** Alibi memory reading  

 Visible only if there is an optional board

The weighing save ID code is expressed as follows: 00000 - 000000, for example 00001 - 000021.

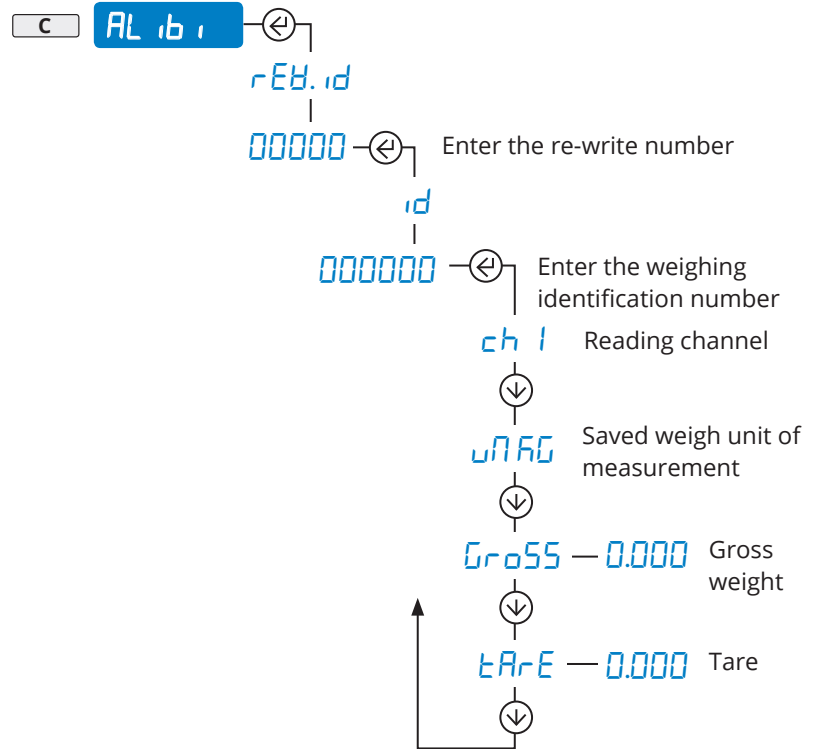
The first value is the re-write number, the second value is the weighing identification number.



**SEtPnt** Relay ports  

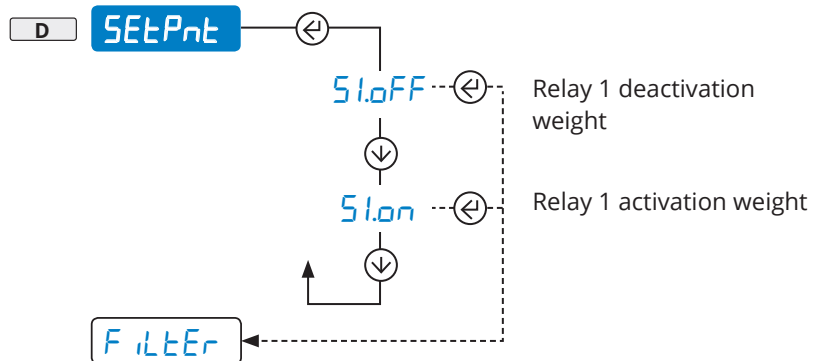

 Visible only if there is an optional board

Relay port activation/deactivation weights



 Repeat the same operation for relays 2, 3 and 4.

How to enter  
1.  5 Sec.

How to browse  
↑ =   
↓ =   
→ =   
← = 

 Page 35

- A **CLock**
- B **PrEC.10**
- C **ALib1**
- D **SEtPnt**
- E **FILtEr** →
- F **SCrEEen**
  - 1 **StAnd.0**
  - ...
  - 4 **StAnd.3**
  - 5 **h irES.0**
  - ...
  - 12 **h irES.7**
  - 13 **dYn.0**
  - ...
  - 16 **dYn.3**
  - 17 **SLoB.0**
  - ...
  - 20 **SLoB.3**
  - 21 **doS.0**
  - ...
  - 24 **doS.3**
  - 25 **rAdC 0**
  - ...
  - 28 **rAdC 5**
- G **tArE**
- H **AutoFF**
- I **onPr in**
- J **t irES**
- K **rESEt**
- L **d iAG**

**FILtEr** Weighing filters



Edits scale reactivity.  
Useful in optimising weighing to your needs.

 With the approved instrument, you can select only some of the filters listed below.

**Premise**

The "0" represents minor filtering incidence.  
Increasing the incidence give the weight more stability.  
We recommend weighing several times, changing the incidence until you obtain the best compromise between reactivity and stability.

Table and floor scales and piece counters

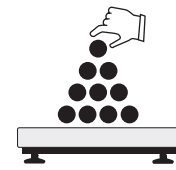
- E-1 **StAnd.0**  
- ...
- E-4 **StAnd.3**





High precision scales

- E-5 **h irES.0** 
- ...
- E-12 **h irES.7**

Suspended and oscillating load weighing

- E-13 **dYn.0** 
- ...
- E-16 **dYn.3**

Liquid weighing, weighbridges and weighing with vibrations

- E-17 **SLoB.0** 
- ...
- E-20 **SLoB.3** 
- ...
-  

Metering, filling, level check and overloads

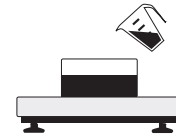
- E-21 **doS.0** 
  - ...
  - E-24 **doS.3** 
- Auto Manuale

Filter for specific applications for use by the manufacturer

- E-25 **rAdC 0**
- ...
- E-28 **rAdC 5**

How to enter  
1. (Left Arrow) 5 Sec.

How to browse

- ↑ = (Up Arrow)
- ↓ = (Down Arrow)
- = (Left Arrow)
- ← = (Right Arrow)

Page 35

- A CLock
  - B PrEC.10
  - C AL ib i
  - D SEtPnt
  - E F iLTER
  - F SCrEEen
  - G tArE
  - H AutoFF
  - I onPr in
  - J t iRrES
  - K rESEt
  - L d iAG
- Navigation from F (SCrEEen):
- 1 bAR.L it
  - 2 br iGht
  - 3 LoCh
  - 4 CoLour

## SCrEEen Adjusting the display



### Backlighting

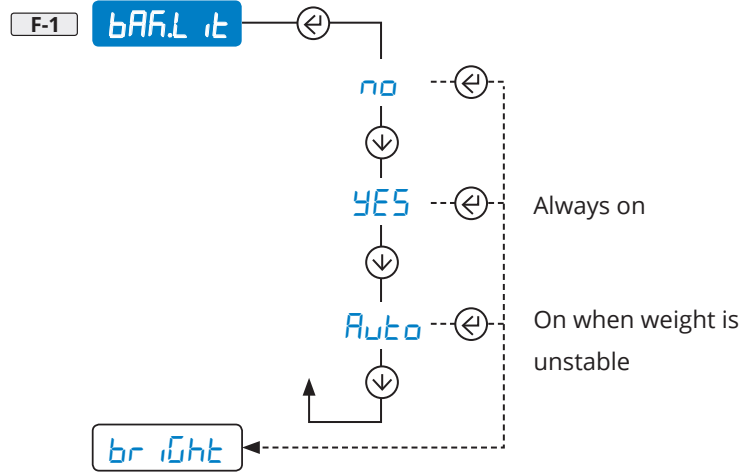

### Brightness

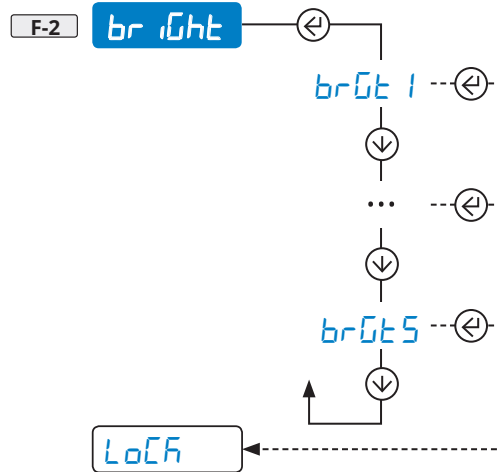

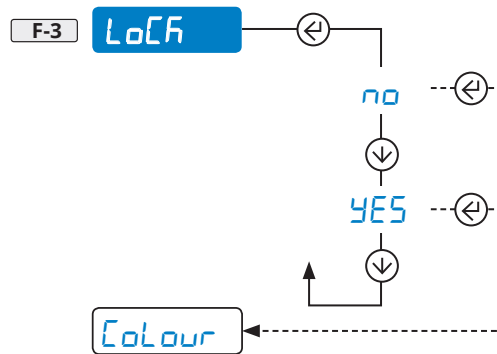

### Display lock (for use by the manufacturer)

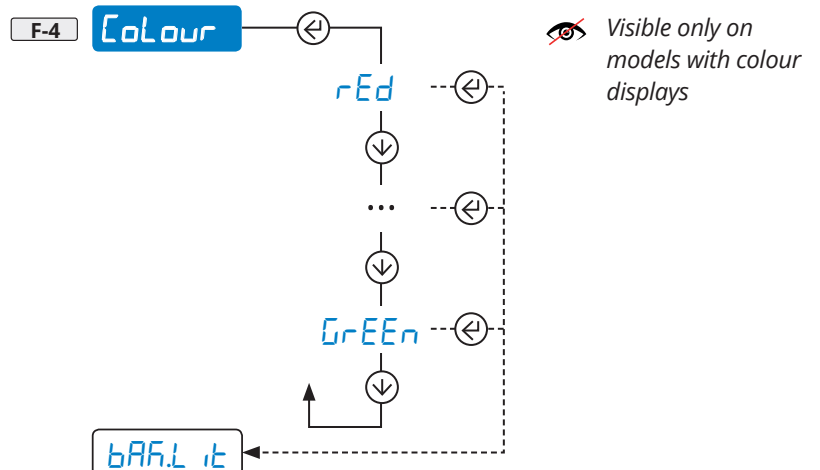

### Backlighting colour (in versions with colour display)



How to enter  
1.  5 Sec.

How to browse  
 =   
 =   
 =   
 = 

 Page 35

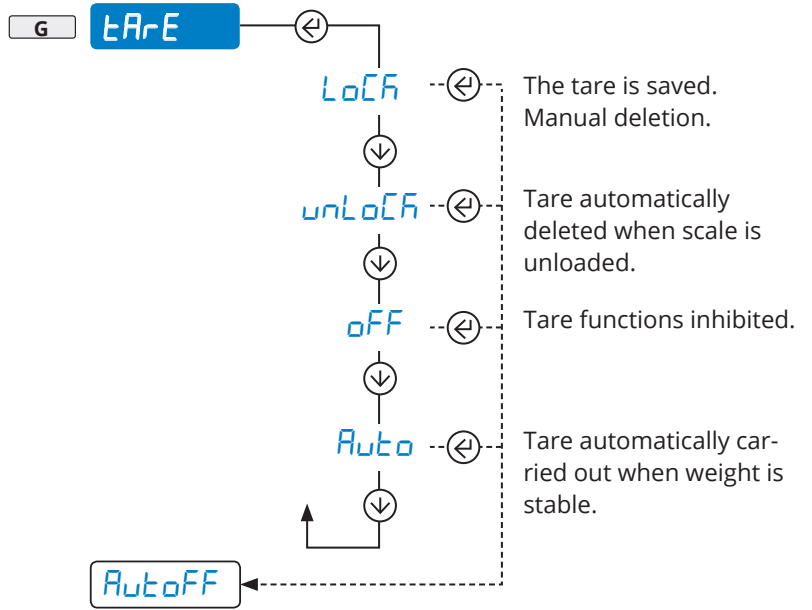

- A CLocH
- B PrEC.10
- C ALib1
- D SEtPnt
- E FILtEr
- F SCrEEr
- G tArE
- H AutoFF
- I onPr in
- J t iFrES
- K rESEt
- L d iAG

**tArE** Tare 

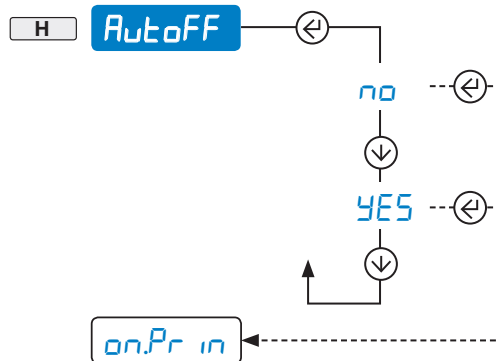

**AutoFF** Automatic switching off 



**onPr in** Manual printer switching on  

 Visible only if there is an integrated printer.

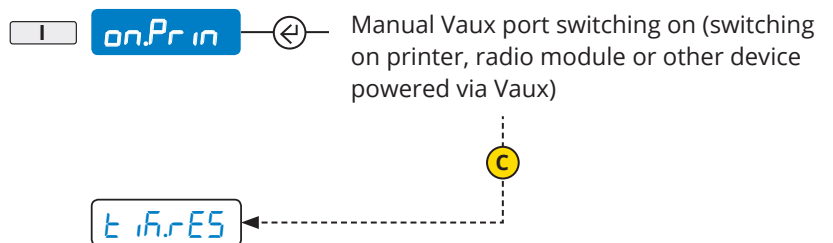



# MENU

How to enter

1. 5 Sec.

Page 35

How to browse

=

=

=

=

A

B

C

D

E

F

G

H

I

J

K

L

## t iRrES Ticket number reset

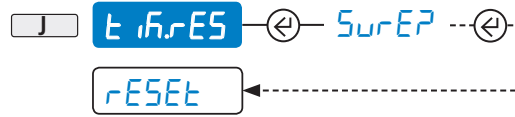

## rESEt Factory configuration reset

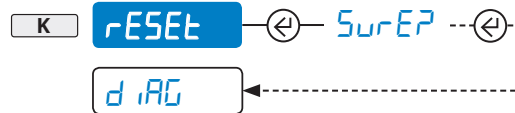

## d iAG Diagnostics

L Reserved for technical staff.



# FAQ

## Frequently Asked Questions

Print .....	43
Accumulation.....	43
Tare.....	43
Weighing .....	44
Piece counter.....	44

## PRINT

---

### The scale does not print

- Another printout is already in progress (бүсү)
- Make sure there is a roll in the printer
- The printer does not switch on
- The weight is unstable (унстай)
- The net or gross weight is negative or is insufficient for printing (Лай)
- Underload or overload (----- o -----) (ун. ойлго)
- The scale was not loaded after the last printing (но. д. ун)
- You are trying to print a non-approved weight

## ACCUMULATION

---

### The scale does not accumulate

- Make sure there is a roll in the printer
- The printer does not switch on
- The weight is unstable (унстай)
- The net or gross weight is negative (Лай)
- Underload or overload (----- o -----) (ун. ойлго)
- The scale was not unloaded after the last printing (но. д. ун)
- The weight is insufficient for weighing (Лай)
  - less than 10 divisions for the accumulator modes
  - less than "Min" for the approved products (shown on the measuring plate)

### The scale has lost the total

- Switching off the scale causes the accumulated totals to be lost

## TARE

---

### The scale does not tare

- The weight is unstable (унстай)
- The gross weight is negative (Лай)
- The weight is insufficient
- The weight exceeds the maximum capacity
- The tare function has been deactivated (see page 35)
- In the event of manual tare, the value exceeds the maximum capacity

## WEIGHING

---

### The scale does not switch on

- Make sure the power cable is connected properly
- Connect the battery charger and try again. If the instrument continues to malfunction, contact the dealer.

### The scale switches off suddenly

- Automatic switching off active
- Low battery
- Battery failure
- Power supply line failure

### The scale is not reactive

- One of the available energy saving modes has been activated
- An unsuitable weighing filter has been selected

### The scale display switches off and displays a dot

- Stand-by mode is active: press a key to reactivate weighing.
- Energy saving mode is active: contact the dealer for further details.

### The scale displays a permanent "Error" message

- The scale is unable to automatically reset the weight because it exceeds the maximum resettable weight at switch-on.
- Unload the scale and try again. If the scale continues to have the same problem even when there is nothing on it, contact the dealer.

### The weight is unstable

- Check the active weighing filter (*see page 35*).
- If the support surface is subjected to vibrations from machinery or moving vehicles, move the scale onto another surface and try again.

## PIECE COUNTER

---

### The scale does not carry out sampling

- The weight is unstable (*Error Flat*)
- The weight is insufficient, add more pieces and try again (*Error*)

## ERROR MESSAGES

MESSAGE	DESCRIPTION	SOLUTION
<i>buSy</i>	Another printout is already in progress	Wait for the printout in progress to be finished and try again.
<i>unStAb</i>	The weight is unstable	Check the weighing filter ( <i>see page 35</i> ). If the support surface is subjected to vibrations from machinery or moving vehicles, move the scale onto another surface and try again.
<i>LoH</i>	The net or gross weight is negative or insufficient for printing	Add weight and try again.
<i>un.oUeR</i>	Underload o overload (..... o .....)	Restore a valid weight condition. If the problem persists, contact customer service.
<i>no.O.unS</i>	The scale was not unloaded after the last printing	Completely unload the scale, making sure the <b>→0←</b> light comes on. Reload the weight and try again.
<i>Err.NoSt</i>	The weight is unstable	Wait for stability (the <b>~</b> light) and try again.
<i>Error</i>	In piece counting mode, the weight is insufficient for proper sampling.	Add more pieces and try again.

## NOTES

---



**HEAD OFFICE**

Via Della Fisica, 20  
41042 Spezzano di Fiorano, Modena - Italy  
Tel. +39.0536 843418 - Fax +390536 843521  
info@diniargeo.com

**SERVICE ASSISTANCE**

Via Dell'Elettronica, 15  
41042 Spezzano di Fiorano, Modena - Italy  
Tel. +39.0536 921784 - Fax +390536 926654  
service@diniargeo.com