

WITH SEAT

# 250-10-4

## BARIATRIC HANDRAIL SCALE

Rice Lake's 250-10-4 bariatric scale with handrail and chair seat is designed for weighing patients who need extra support and safety during weighments. Patients can be weighed comfortably and safely while seated with the large, stable folding seat. Advanced movement compensation technology eliminates errors caused by involuntary movement of unsteady patients. Two heavy-duty rear wheels make it simple and effortless to move and store.

### FEATURES

- Handrail for support and safety
- Padded seat with backrest
- Two wheels for ease of portability
- Large 1-inch LCD display
- Nonslip platform
- Unit of measure toggle or locking
- Motiontrap™ movement compensation technology
- EMR capable
- Serial and USB data communication ports
- Bluetooth® BLE 4.0 available, part number selectable
- Tare function
- Hold function
- BMI (body mass index) function
- Factory calibrated

### SPECIFICATIONS

**Capacity:**

1,000 × 0.2 lb (450 × 0.1 kg)

**Platform Dimensions:**

(L × W × H)  
25 × 20 × 3 in

**Power:**

9 VDC, provided by six AA alkaline batteries (included) or AC adapter (optional)

**Battery Type:**

Six AA alkaline (included)

**Battery Use:**

25 hours continuous use with batteries  
Automatic power-off can be configured

**Operating Temperature:**

50 °F to 104 °F (10 °C to 40 °C)

**Display:**

5-digit LCD display, 0.75 in (1.9 cm) digit height

**Approvals:**

c-Met, E113986

**Warranty:**

Two-year limited





## BARIATRIC HANDRAIL SCALE

MODEL	CAPACITY	COMMUNICATION	PART #
250-10-4	1,000 × 0.2lb (450 × 0.1kg)	USB	133120
250-10-4BLE	1,000 × 0.2lb (450 × 0.1kg)	Bluetooth® BLE 4.0	194734

## OPTIONS

DESCRIPTION	PART #
9 VDC adapter, 120 V/230 V auto switching c-MET* <i>Medical grade power supply</i>	115655
9 VDC adapter, 120 V/230 V auto switching*	133077
9 VDC adapter, 230 V**	102508
Epson TM-U220 tape printer	81076
Cable, RS232 scale to printer, 6 ft, 25-pin D-Sub (male) to RJ45	186830
Cable, USB 6 ft USB-A (male) to USB-B (male)	79074
Cable, Communication DB9 (female) to RJ45 (male), 4 conductor	217091

\*NEMA 1-15 Plug  \*\*CEE 7/16 Plug 

## SHIPPING WEIGHT

MODEL #	PART #	L (IN)	W (IN)	H (IN)	PACKAGE WGT. (LB)	DIM WGT. (LB)	SHIPPING WGT. (LB)
250-10-4	133120	32	27	46	70	286	286
250-10-4BLE	194734	32	27	46	70	286	286

## DIMENSIONS

	INCHES	CENTIMETERS		INCHES	CENTIMETERS
<b>A</b>	2.8	7.0	<b>E</b>	32.0	81.1
<b>B</b>	25.7	65.3	<b>F</b>	47.5	120.7
<b>C</b>	25.2	64.0	<b>G</b>	20.0	50.8
<b>D</b>	21.6	54.9	<b>H</b>	12.0	30.5

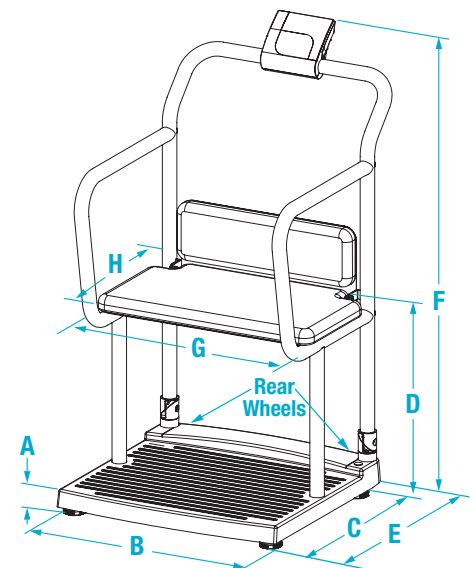

An ISO 9001 Registered Company ©2024 Rice Lake Weighing Systems 03/24  
Specifications subject to change without notice. Visit [ricelake.com](http://ricelake.com)

