

NONSLIP METAL  
PLATFORM

# 350-10-3M

## DUAL-RAMP WHEELCHAIR SCALE

Rice Lake's 350-10-3M is a dual ramp, metal wheelchair scale in the 350-10 Series family. This durable scale offers accurate, high-capacity weighing for a wide range of patients. The 350-10-3M has a large, stable scale base with a nonslip surface to ensure safety during patient weighing. Easy to set up, this foldable scale can be quickly moved on two heavy-duty rear wheels for efficient patient weighing in different locations.

### FEATURES

- Large LCD display
- Antimicrobial keypad
- Two wheels for portability
- Dual ramp
- Nonslip platform
- Motiontrap™ movement compensation technology
- Unit of measure toggle or locking
- EMR capable
- Serial and USB data communication ports
- Bluetooth® BLE 4.0 available, part number selectable
- Tare function
- Hold function
- BMI (body mass index) function
- Factory calibrated
- Easy to store, folded depth is 11.75 in (29.8 cm)

### SPECIFICATIONS

**Capacity:**  
1,000 × 0.2 lb (450 × 0.1 kg)

**Platform Dimensions:**  
(L × W × H)  
29.50 × 31.50 × 3.15 in

**Power:**  
9 VDC, provided by six AA alkaline batteries (included) or AC adapter (optional)

**Battery Type:**  
Six AA alkaline (included)

**Battery Use:**  
25 hours of continuous use with batteries  
Automatic power-off can be configured

**Display:**  
5-digit LCD display, 0.75 in (1.9 cm) digit height

**Temperature:**  
Operating:  
50 °F to 104 °F (10 °C to 40 °C)

**Warranty:**  
Two-year limited





## WHEELCHAIR SCALE

MODEL	CAPACITY	COMMUNICATION	PART #
350-10-3M	1,000 × 0.2lb (450 × 0.1 kg)	USB	193956
350-10-3MBLE	1,000 × 0.2lb (450 × 0.1 kg)	Bluetooth® BLE 4.0	203910

## OPTIONS

DESCRIPTION	PART #
9 VDC adapter, 120 V/230 V auto switching c-MET* <i>Medical grade power supply</i>	115655
9 VDC adapter, 120 V/230 V auto switching*	133077
9 VDC adapter, 230 V**	102508
Epson TM-U220 tape printer	81076
Cable, RS232 scale to printer, 6 ft, 25-pin D-Sub (male) to RJ45	186830
Cable, USB 6 ft USB-A (male) to USB-B (male)	79074
Cable, Communication DB9 (female) to RJ45 (male), 4 conductor	217091

\*NEMA 1-15 Plug  \*\*CEE 7/16 Plug 

## SHIPPING WEIGHT

MODEL #	PART #	L (IN)	W (IN)	H (IN)	PACKAGE WGT. (LB)	DIM WGT. (LB)	SHIPPING WGT. (LB)
350-10-3M	193956	51	42	14	102	216	216
350-10-3MBLE	203910	51	42	14	102	216	216

## DIMENSIONS

	INCHES	CENTIMETERS		INCHES	CENTIMETERS
<b>A</b>	3.15	8.0	<b>E</b>	31.50	80.0
<b>B</b>	47.70	121.2	<b>F</b>	29.50	74.9
<b>C</b>	37.80	96.0	<b>G</b>	2.40	6.1
<b>D</b>	45.30	115.1	<b>H</b>	27.20	69.1

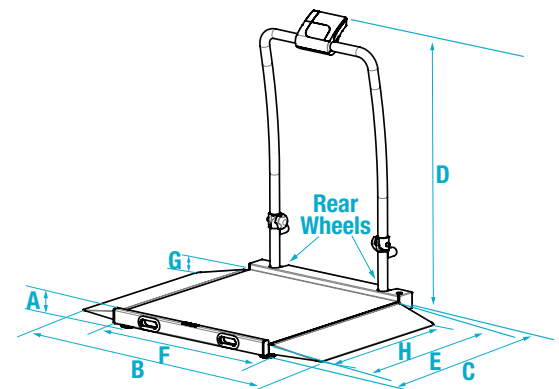

An ISO 9001 Registered Company ©2025 Rice Lake Weighing Systems 01/25  
Specifications subject to change without notice. Visit [ricelake.com](http://ricelake.com)

