

# BenchMark® HD-3 Aviation

Heavy Duty Bench Scale

BENCH SCALES

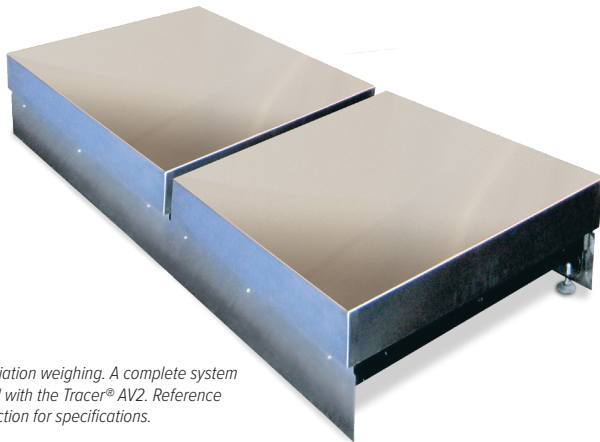

*Ideal for aviation weighing. A complete system can be sold with the Tracer® AV2. Reference Aviation section for specifications.*

## Approvals



Measurement  
Canada  
Approved



## Part Number/Price

Part #	Capacity	Platform Dimensions	Price
Consult	500 lb (225 kg)	W × D × 12 in	Consult

*Note: Maximum size is up to 36in × 36in, height is always 12in  
W × D supplied by customer.*

## Standard Features

- Two heavy-duty scales designed mild steel base construction with 304 stainless steel cover
- Polyurethane rubber leveling feet with stainless steel stems
- Load cell comes standard with DB-9 connector for connecting to Tracer AV2
- Front and back kick plates for two side-by-side scales

## Specifications

### Load Cell, NTEP Certified:

IP67 aluminum, environmentally sealed

### Output Impedance:

350 ohm

### Maximum Overload:

200%

### Overload Protection:

Five-point, independently adjusted

### Cable Length:

10 ft (3 m)

### Temperature:

Compensated:

14 °F to 104 °F (-10 °C to 40 °C)

### Warranty:

Two-year limited

### Approvals:

NTEP 06-010, Class III 5,000 d

Measurement Canada AM-5625

Load cell is cFMus approved

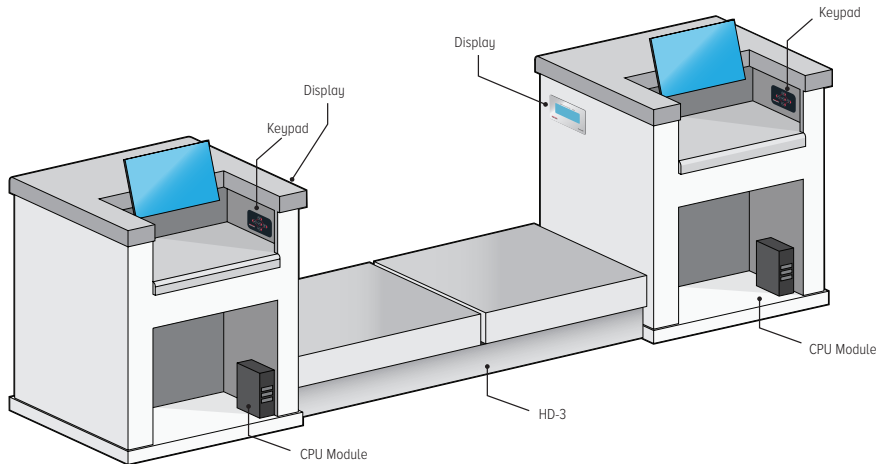

*Baggage weighing system with Benchmark HD-3 and Tracer AV2 Single LCD Panel Mount Display, Single keypad*

# BenchMark® HD-3 Aviation

Heavy Duty Bench Scale

BENCH SCALES

