

SINGLE POINT  
**PW15AH**

Stainless Steel, Hermetically Sealed, NTEP Certified 1:5,000 Class III Single Cell, OIML C3, IP69K

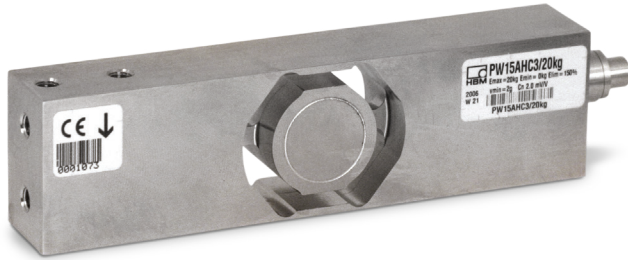

Picture is a representation of actual product.

Approvals



Order Information

Load Rating	Part #	Est. Weight	Price
10 kg	101915	3 lb	Consult
20 kg	101916	3 lb	Consult
50 kg	101917	3 lb	Consult
100 kg	101918	3 lb	Consult

Dimensions

Rated Capacity	B	E	F	G	H	I	J
kg/mm							
10 to 100	19.0	25.0	75.0	100.0	17.5	40.0	150.0

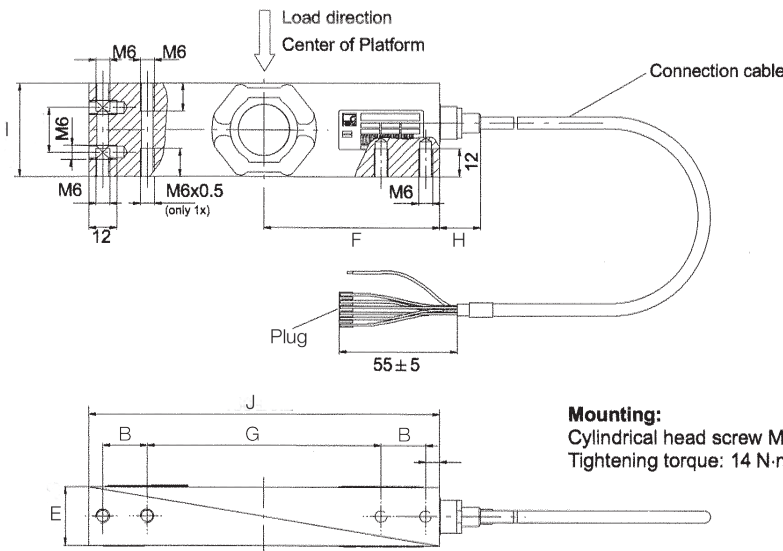

Interchangeable Products

RICE LAKE WEIGHING SYSTEMS  
**RLPWM15HE**.....page 155  
 FLINTEC®  
**PC4**..... page 217

Specifications

- Full Scale Output:**  
2.0 mV/V
- Output Resistance:**  
350 (± 10) ohm
- Input Resistance:**  
380 (± 15) ohm
- Material/Finish:**  
Stainless steel
- Temperature:**  
Compensated:  
14 °F to 104 °F (-10 °C to 40 °C)  
Operating:  
0 °F to 150 °F (-18 °C to 65 °C)
- Seal Type:**  
Hermetically sealed, IP69K
- Safe Overload:**  
150% full scale
- Rated Excitation:**  
5 to 15 VDC
- Combined Error:**  
0.02% full scale
- Insulation Resistance:**  
1,000 megohm
- Cable Length:**  
10 ft
- Cable Diameter:**  
0.212 in  
PVC jacket
- Cable Color Code:**  
Blue +Excitation  
Black -Excitation  
White +Signal  
Red -Signal  
Green +Sense  
Grey -Sense
- Warranty:**  
One-year limited
- Approvals:**  
NTEP  
OIML  
FM