

# iDimension® Flex Series

Pallet and Box Static Dimensioning System

DIMENSIONING



Suspended or Free-standing mount options available

## Standard Features

- Floor mounted free-standing frame or suspend from the ceiling
- One high resolution camera (one additional camera available)
- Install/integrate with a floor scale, conveyor or pallet stretch wrapper
- Easy two-person assembly
- Legal for Trade dimensions in under 2 seconds
- Network integration tool kit
- Top side junction box

## Applications

- Pallet dimensioning, above a target zone, scale, conveyor or stretch wrapper to dimension cuboidal and irregular freight.

## Options

- Kiosk pedestal base available
- Second high resolution camera
- Additional sensor to assist reading black stretch film
- Weigh scale and indicator not included

## Specifications

### Legal for Trade Measurement Capability:

Min: 12 × 12 × 12 in (300 × 300 × 300 mm)  
Max: 96 × 96 × 96 in (2,438 × 2,438 × 2,438 mm)

### Power Requirements:

110 to 240 VAC  
25 ft (7.62 m) U.S. power cable included

### Communication Ports:

Ethernet TCP/IP, USB, Serial RS232

### Temperature:

14 °F to 104 °F (-10 °C to 40 °C)

### Humidity:

0 to 90% non-condensing

### Warranty:

Two-year limited  
Five-year limited, sensors only

### Approvals:

NTEP 19-076A4  
OIML  
CE Marked  
FCC  
MID Certified

## Approvals



## Part Numbers/Price

Part #	Description	Price
219294	Free-standing 80/20 frame, four-sensors, one camera, industrial PC, kiosk, software integration tool kit, REST API	Consult
219292	Suspend from ceiling, four-sensors, one camera, industrial PC, kiosk, software integration tool kit, REST API. Mounting hardware sold separately	Consult

## Options/Accessories

Part #	Description	Price
<b>Accessories</b>		
200168	2.4 mm POE network camera	Consult
219194	Kiosk pedestal base	Consult
220137	Mounting kit to attach kiosk to 219294 free-standing Flex	Consult
212260	Kiosk shelf for printer or scanner	Consult
220146	Optional 5th sensor to assist with scanning black stretch film	Consult
205283	80/20 mounting kit, 25 ft high max ceiling height	Consult
188757	Aircraft wire kit for ceilings less than 35 ft	Consult
214187	RoughDeck floor scale 5 × 5 ft HC, 2,500 kg, flat black paint, Measurement Canada Certified	Consult
213921	RoughDeck floor scale 5 × 5 ft HP, 5,000 lb, flat black paint, NTEP Certified	Consult
86873	Bumper guard, HP 5 ft	Consult
213999	RoughDeck ramp, 5 ft	Consult
200183	680 Plus Indicator, LED display, 115 to 230 VAC with RJ45, US power cord. Alternately, choose a 1280 for automation applications.	Consult
<b>Barcode Scanner</b>		
225020	QuickScan QD2590 USB barcode scanner	Consult
206229	Honeywell wireless long-range TCP/IP barcode scanner kit	Consult
<b>Factory Service and Support</b>		
224761	One time license fee at time of purchase	Consult
FLD-Install	iDimension field install/training day, travel and expenses not included	Consult
202029	Hourly rate scheduled integration services remote session	Consult
<b>Extended Warranty – Two-year standard</b>		
202033	iDimension Flex/PWD/LTL additional one-year extended warranty	Consult



iDimension Flex Series Kiosk

iDimension Flex Series Kiosk with Optional Pedestal

# iDimension® Flex Series

Pallet and Box Static Dimensioning System

## Dimensions

iDimension Flex Free Standing	
A	145.38 in (3,693 mm) max
B	93.00 in (2,362 mm)
C	104.88 in (2,664 mm) max
D	105.00 in (2,667 mm) max
E	85.08 in (2,161 mm)

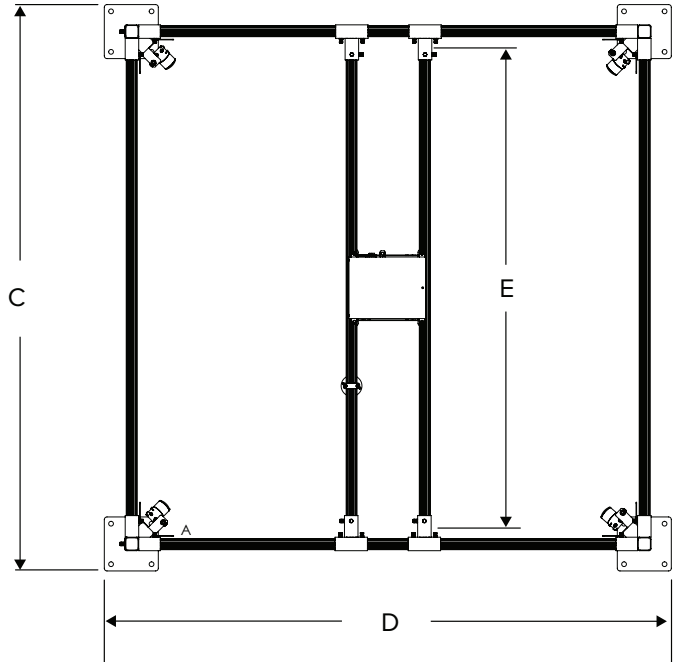
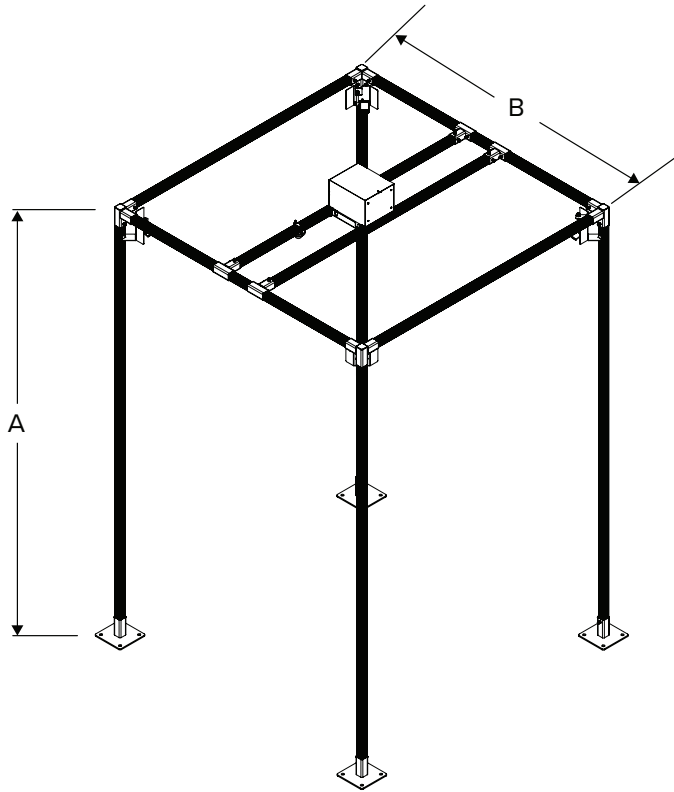

## Dimensions

iDimension Flex Suspension	
A	88.12 in (2,238 mm)
B	88.12 in (2,238 mm)

