

## Specifications

### WRAPPING UNIT

#### Capacity:

0.10 to 7.70 lb (0.04 to 3.5 kg)

#### Packs/Minute Max:

Up to 15 ppm

#### Wrapping Size:

Width: 5.9 to 15.0 in  
Depth: 5.0 to 9.6 in  
Height: 0.4 to 5.1 in  
Tray Type PSP, PP, PET, Paper

#### Film Type

Polyolefin/PVC  
(film type suitable for automatic wrapping)  
Film Size 400, 450, 500 mm

#### Outer Diameter:

7.9 in (200 mm) or less

### SCALE UNIT

#### Capacity/Division:

0-15 lb × 0.005 lb/15-30 lb × 0.01 lb  
(multi-interval)  
0-30 lb × 0.01 lb (single range)  
0-6 kg × 0.002 kg/6-15 kg × 0.005 kg  
0-15 kg × 0.005 kg

#### Accuracy:

1/3000

#### Min. Print Weight:

0.1 lb (0.04 kg)

### PRINTER UNIT

#### Print Head:

3 inch direct thermal (960 dots), 12 dots/mm

#### Printing Speed:

120 mm/sec

#### Print Area:

With Liner: Width: Up to 2.9 in (76 mm)  
Linerless: Width: Up to 3.0 in (77 mm)

#### Label Size:

With Liner:  
Width: 1.1 to 3.1 in (30 to 80 mm)  
Length: 0.9 to 4.1 in (23 to 105 mm)  
Linerless:  
Width: 1, 2, 3 in (44, 60, 80 mm)  
Length: 1.1 to 19.6 in (30 to 500 mm)

#### Label Roll Size:

4.9 in (125 mm)

#### Inner Core Diameter:

1.5 in (40 mm)

#### Label Storage Capacity:

With Liner: 1,820 labels/roll  
Linerless: 2,700 labels/roll

### CONTROLLER UNIT

#### Display:

Backlit 12.1 in XGA (800 × 600) TFT Color LCD

#### Tactile Keys:

19 Keys

### GENERAL

#### Interface:

USB: 4 ch  
10/100 base Ethernet: 1 ch

#### Memory Capacity:

1 GB

#### Power Supply:

Single phase, 200-240 V, 50/60 Hz

#### Power Consumption Max:

Operation: 1200 W or less  
Standby: 1000 W or less  
Sleep mode: 200 W or less

#### Operational Environment:

Temperature: 41 °F to 95 °F (5 °C to 35 °C)  
Humidity: 20-85%RH (without condensation)

#### Machine Weight:

With Liner: Approx. 283.7 lb (128.5 kg)  
Linerless: Approx. 286.0 lb (129.8 kg)

#### Noise Label:

73 dB or less

#### Option:

Wireless LAN unit, film roll protection cover unit, -10 mm infeed pusher

#### Classification:

NTEP CC 06-029A7

#### Warranty:

One-year limited Based on volume of 900 packs per day using recommended film



## Ishida WM-Micro

### Compact Wrapper with Integrated Color Touchscreen Scale and Printer

Reduce operator fatigue and increase production with the second generation compact automatic wrapper. The WM-Micro is the ideal solution for grocers and markets with limited space needing high performance and consistent wrapping.

The generous infeed accommodates a wide range of trays, from a 2 to a 25SH and wraps up to 7.5 lb packs, and uses film 16 to 22 inches wide.

Linerless model includes an integrated auto-cutter for clean edge labels.

The WM-Micro employs the power and flexibility of a LINUX OS with color touchscreen and integrated 3 inch thermal printer.

## Standard Features

- Weigh/wrap and label up to 15 packs/minute
- Large LCD color touchscreen (12.1 in)
- Adjustable touchscreen viewing angle
- Dual-range weighing 0 to 15 × 0.005 lb/ 15 to 30 × 0.01 lb)
- Stores and prints graphics for custom labeling
- Large 5 in diameter label roll and 3 in wide thermal head
- Static TCP/IP Ethernet communication
- 19 tactile keys with cover

PART #	MODEL	CAPACITY
223814	WM-Micro compact wrapper with integrated color touchscreen scale and printer	15 × 0.005 lb/30 × 0.01 lb
226173	WM-Micro Linerless compact with integrated auto-cutter color touchscreen scale and printer	15 × 0.005 lb/30 × 0.01 lb

Please refer to the labels section of this catalog for ordering information and case quantity pricing.

# Ishida WM-Micro

Compact Wrapper with Integrated Color Touchscreen Scale and Printer

PART #	MODEL/DESCRIPTION	CAPACITY	EST. SHIPPING WEIGHT	PRICE
223814	WM-Micro compact wrapper with integrated color touchscreen scale and printer	0 to 15 × 0.005 lb/15 to 30 × 0.01 lb	325 lb	Consult
226173	WM-Micro Linerless compact with integrated auto-cutter, color touchscreen scale and printer	0 to 15 × 0.005 lb/15 to 30 × 0.01 lb	340 lb	Consult

## Options/Accessories

121076	Stand, stainless steel with leveling legs, 28 × 26 × 27 in (W × D × H)			Consult
125578	Day Glow label dispenser, 25-3/4 × 7-5/8 in aluminum, 20 roll capacity includes the arms that mount the Day Glow dispenser to the stand (PN 121076)			Consult
151761	Day Glow label dispenser spacer, pack of ten			Consult
121077	Plastic washdown cover, short for use with WM-Micro on optional stand			Consult
125417	Plastic washdown cover, tall for use with Day Glow label dispenser			Consult

## Communication

152628*	ScaleLink Pro 5 license file, one license required per computer			Consult
78860	Cross cable, Ethernet CAT5, 6 ft			Consult

## Manuals and Service Tools

Consult	Additional user's manual			Consult
Consult	Service manual			Consult
Consult	Setup manual			Consult
95540	Service key, safety switch door			Consult
Consult	USB flash memory, 1 GB			Consult

## Label Stock

Please refer to labels section of this catalog for ordering information and case quantity pricing

## Wrapping Film

181916	400mm × 1,000m (15.7 in × 3,280ft) one box of two rolls		28 lb	Consult
187821	450mm × 1,000m (17.7 in × 3,280ft) one box of two rolls		35 lb	Consult
170110	500mm × 1,000m (19.7 in × 3,280ft) one box of two rolls		38 lb	Consult
203761	550mm × 1,000m (21.7 in × 3,280ft) one box of two rolls		42 lb	Consult

\*Software key is provided after online registration is completed

\*\*Manuals and software programs can be downloaded from the distributor section of [www.ricelake.com/retail](http://www.ricelake.com/retail).

### WM-Micro Series Financial Terms and Conditions

Our financial services group reviews open account requests. Upon approval of open account terms, orders may be subject to the following payment terms: 20% down with the order

# Ishida WM-Micro

DIMENSIONS			
<b>A</b>	31.5 in (800 mm)	<b>E</b>	34.1 in (866 mm)
	32.4 in (823 mm) linerless	<b>F</b>	29.8 in (757 mm)
<b>B</b>	33.5 in (851 mm)	<b>G</b>	12.2 in (310 mm)
<b>C</b>	28.9 in (734 mm)	<b>H</b>	16.7 in (424 mm)
<b>D</b>	29.1 in (739 mm)		

**Top Down**

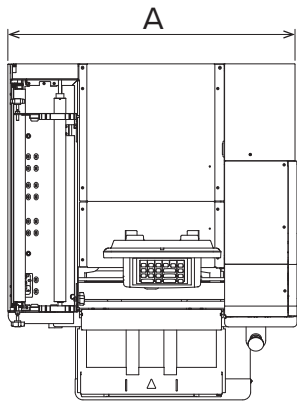

**Front**

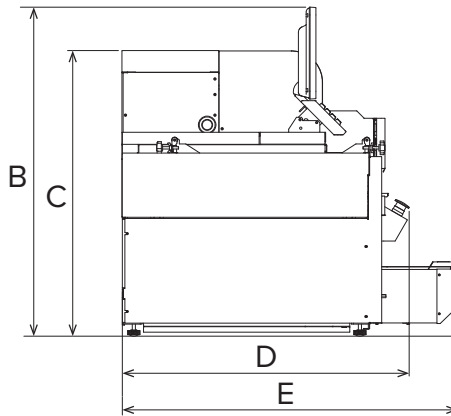

**Side**

