

# JB1010ST

Signal Trim Junction Box

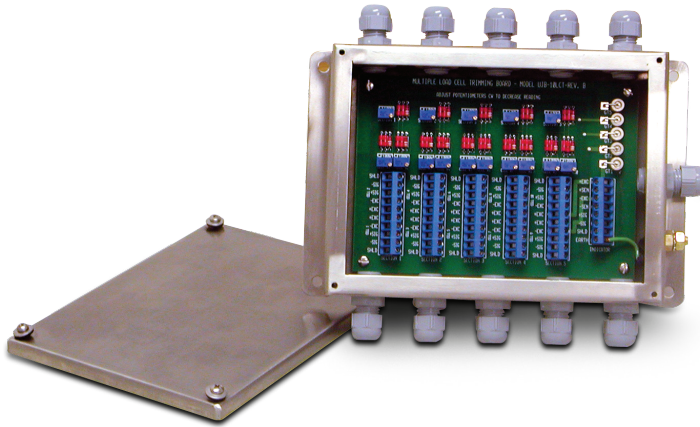

## Standard Features

- Transient protection using gas discharge tubes
- Stainless steel, NEMA Type 4X enclosure
- Section and individual cell trim capability
- Compact enclosure only 1.75 in deep
- Strain relief cable fitting
- Number of cells: two, four, six, eight or 10 single load cells
- Legal for Trade sealing screws, wire and seal included

## Applications

- Tank, truck and railroad scales
- Summing 10 load cells with individual and section trimming capability

## Specifications

### Cable Fittings:

Eleven nylon 0.079 to 0.314 in cable strain reliefs

### Rating/Material:

NEMA Type 4X  
Stainless steel

### Connectors:

Electrovert 0.197 miniature screw terminals  
Five positions  
Maximum wire size: #14 AWG  
External enclosure ground stud

### Trimming:

Individual cell and section signal trim

### Temperature:

Operating:  
0 °F to 122 °F (-18 °C to 50 °C)

### Potentiometers:

100,000 ohm, 25-turn cermet, individual trim  
100 ohm, for section trimming

### Warranty:

One-year limited

## Part Number/Price

Part #	Description	Price
68813	JB1010ST signal trim junction box	Consult
68811	Board only	Consult
165277	Enclosure only (includes cord grips)	Consult

Note: Do not mix junction box models or use other brands of junction boxes with Rice Lake junction boxes. There is a risk of system instability. Any unused channels require modification.

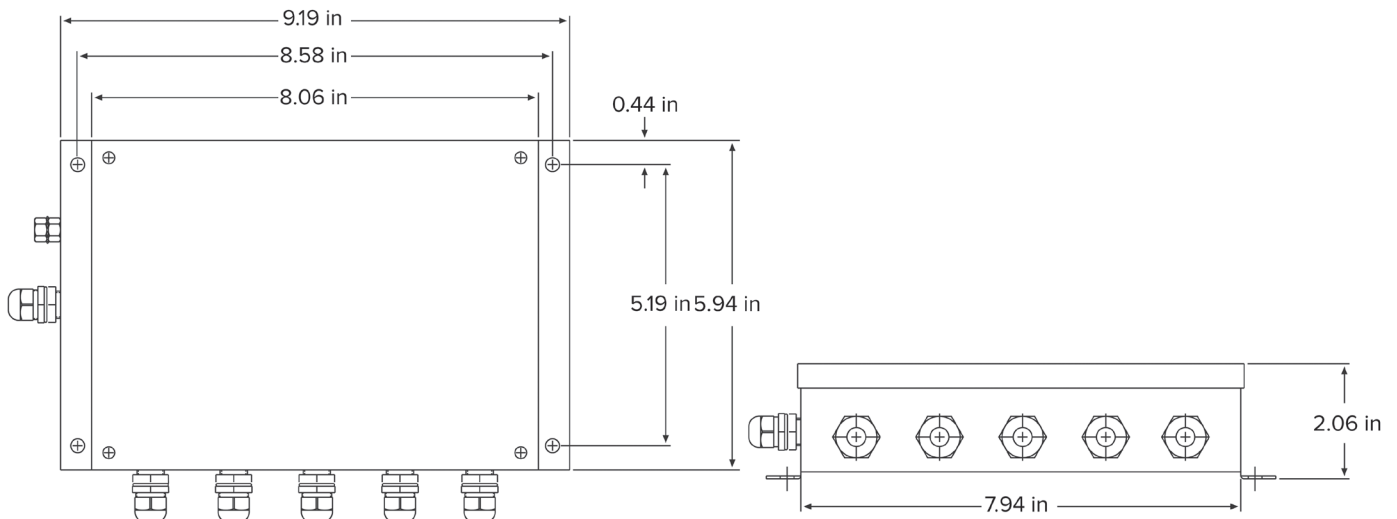
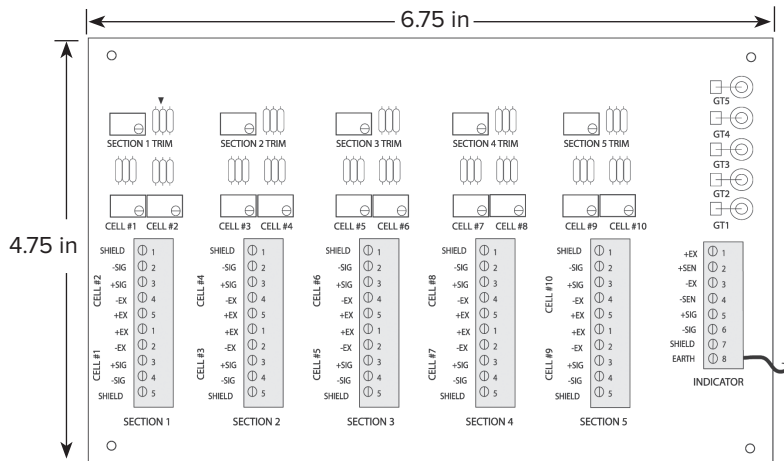

JUNCTION BOXES / SIMULATORS