

MagnaMount™

Mount Assembly

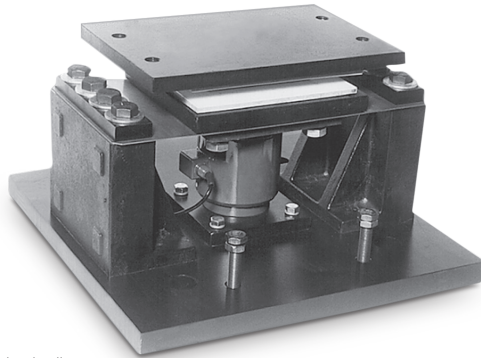

Mount only; does not include load cell.
Picture is a representation of actual product.

Standard Features

- Capacities (per module): 50,000 lb, 100,000 lb and 200,000 lb
- Protects load cell from shock and side loads
- Low-profile design
- High-strength load bearing plate made of highgrade carbon steel hardened to Rockwell C 48-54
- PTFE coated shock absorbing pads
- Compatible with VPG® Revere CP and CSP and Rice Lake Weighing Systems RLCSP1 NTEP Certified load cells

Applications

- Truck scale mount*
- Heavy-capacity horizontal tanks*
- Railroad track mount*

Order Information

Load Rating (Per Module)	Part #	Price
50,000 lb	21723	Consult
100,000 lb	21724	Consult
200,000 lb	17974	Consult

Mount only; does not include load cell

*Check rods required

Dimensions

Rated Capacity	C	H	L	L1	L2	L3	L4	T	W	W1	W2	W3	W4	W5
lb/in														
50,000	1.25	7.39	13.00	1.75	11.25	8.50	1.37	3/4-10 UNC	12.00	1.75	8.50	8.00	4.50	1.75
100,000	1.50	11.29	20.00	2.25	18.00	15.50	1.25	7/8-9 UNC	17.00	2.50	12.00	9.00	5.50	1.75
200,000	2.00	14.10	26.00	5.00	19.00	16.00	1.50	1-8 UNC	26.00	5.00	16.00	12.50	5.50	3.50

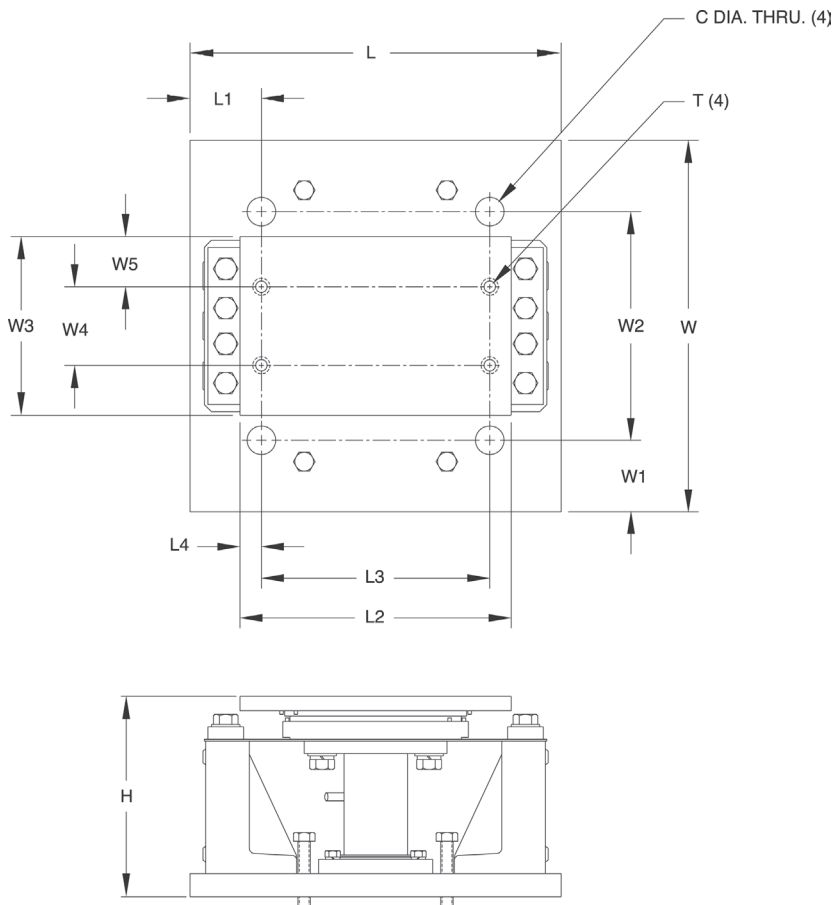

WEIGH MODULES