

MS202

Permanent Monorail Scale

MONORAIL SCALES

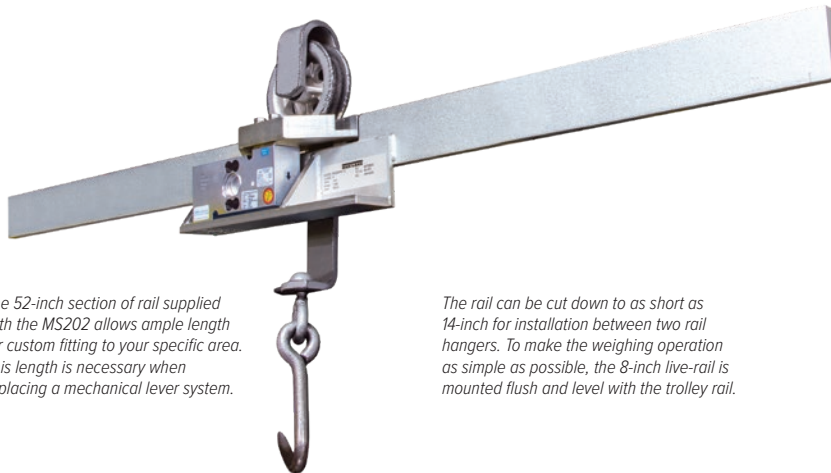

The 52-inch section of rail supplied with the MS202 allows ample length for custom fitting to your specific area. This length is necessary when replacing a mechanical lever system.

The rail can be cut down to as short as 14-inch for installation between two rail hangers. To make the weighing operation as simple as possible, the 8-inch live-rail is mounted flush and level with the trolley rail.

Approvals



Measurement
Canada
Approved

Part Number/Price

Part #	Description	Est. Weight	Price
MS202HB for 3/8-inch Rails			
19744	MS202HB-3/8 in, 750 lb x 0.5 lb, nickel-plated	38 lb	Consult
196885	MS202HB-SS 3/8 in, 750 lb x 0.5 lb, stainless steel	38 lb	Consult
MS202HB for 1/2-inch Rails			
213003	MS202HB, 1500 lb x 0.5 lb, nickel-plated	40 lb	Consult
213004	MS202HB, 1500 lb x 0.5 lb, stainless steel	40 lb	Consult

Options/Accessories

Part #	Description	Price
16984	Additional operating manual	Consult
167585	Replacement load cell for 750 lb cap monorail, model SPT 1510-500 kg, 25 ft cable	Consult
87036	Replacement load cell for 1,500 lb cap monorail, model RLPCBC-60, 1000 kg, 15 ft cable	Consult
216728	Configuration and Monorail calibration	Consult

Standard Features

- 8-in live-rail designed to weigh one trolley at a time
- 750 x .5 lb (3/8 inch rail)
- 1500 x .5 lb (1/2 inch rail)
- Available for rail sizes 3/8 x 2- 1/2 in or 1/2 x 2- 1/2 in
- Requires less than 41 in of straight rail to install (14 in between rail hangers)
- Nickel-plated mild steel and stainless steel construction available
- High accuracy, stainless steel load cell
- 20 ft of cable on 750 lb capacity models
- 15 ft of cable on 1500 lb capacity models
- Slightly recessed live-rail for the trolley roller provides stable weighments

Specifications

Construction:

Nickel-plated mild steel or stainless steel construction

Load Cell Construction:

Stainless steel

Bridge Resistance:

350 ohms nominal

Rated Output:

2 mV/V

Nonlinearity:

0.03% full scale

Warranty:

One-year limited

Approvals:

NTEP CC 90-003 Class III, NMAX 1500
Measurement Canada

Dimensions

MS202	
750 lb Capacity	
A	52.00 in (±0.03 in) (1,321 mm ±0.76 mm)
B	0.75 in (19 mm)
C	0.19 in (5 mm)
D	0.060/0.020 in (2/0.5 mm)
E	2.50 in (63.5 mm)

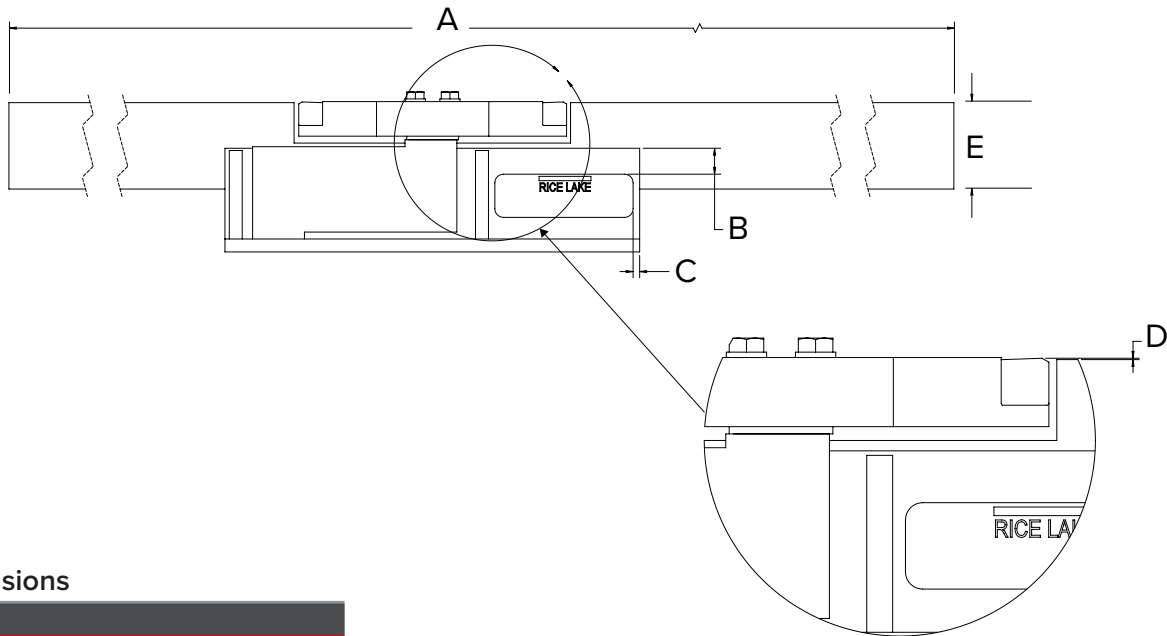

MONORAIL SCALES

Dimensions

MS202	
1,500 lb Capacity	
A	52.00 in (±0.03 in) (1,321 mm ±0.76 mm)
B	4.66 in (118 mm)
C	8.00 in (203 mm)
D	4.59 in (117 mm)
E	2.50 in (64 mm)

