



### Standard Features

- Large front and rear display
- Traffic light function
- Battery powered
- Built-in USB-C and USB-A

### Specifications

**Power:**

100 to 240 V, 50/60 Hz AC adapter  
 Internal battery, rechargeable lithium battery

**Battery Operation Time:**

Up to 500 hours continuous use between recharges with 12 hour recharge time

**Rating/Material:**

ABS housing/stainless steel 304 load plate, IP43

**Display:**

Front and rear LCD, up to 1.4 in (35 mm), six-digit, 14-segment, white backlight

**Temperature:**

Operating:  
 14 °F to 104 °F (-10 °C to 40 °C)

**Warranty:**

Two-year limited, pending evaluation

### Part Number/Price

Part #	Minebea PN	Description	Price
218584	EF-ST2-P1	3 × 0.0001 lb (1.5 × 0.00005 kg)	Consult
218585	EF-ST2-P3	6 × 0.0002 lb (3 × 0.0001 kg)	Consult
218586	EF-ST2-P6	15 × 0.0005 lb (6 × 0.0002 kg)	Consult
218587	EF-ST2-P15	30 × 0.001 lb (15 × 0.0005 kg)	Consult
218588	EF-ST2-P30	60 × 0.002 lb (30 × 0.001 kg)	Consult

### Options/Accessories

Part #	Description	Price
218599	Replacement power adapter	Consult

### Dimensions

SmallTall		
A	9.69 in (246 mm)	E 5.43 in (138 mm)
B	11.90 in (302 mm)	F 9.76 in (248 mm)
C	8.67 in (220 mm)	G 1.57 in (Ø40 mm)
D	7.17 in (182 mm)	

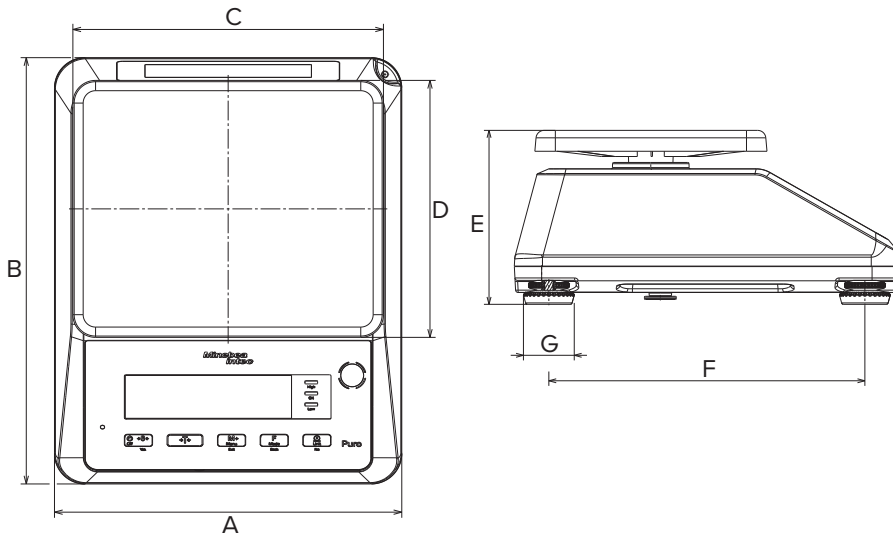

PRECISION INDUSTRIAL WEIGHING