

Ready-n-Weigh Bench Scale System

CW-90B Bench Scale and 380 Indicator Package

BENCH SCALES



Approvals



Measurement
Canada
Approved



CW-90B with 380 Package

Part #	Capacity	Dimensions (L x W x H)	Est. Weight	Price
208528	5 lb (2.5 kg)	10 x 10 x 4.25 in	24 lb	Consult
208529	10 lb (5 kg)	10 x 10 x 4.25 in	24 lb	Consult
208530	25 lb (10 kg)	10 x 10 x 4.25 in	24 lb	Consult
208531	25 lb (10 kg)	12 x 12 x 4.25 in	27 lb	Consult
208532	50 lb (25 kg)	12 x 12 x 4.25 in	27 lb	Consult
208533	100 lb (50 kg)	12 x 12 x 4.25 in	27 lb	Consult

Options/Accessories

Part #	Description	Price
206433†	External AC adapter	Consult
204258	Real-time clock module	Consult



† US plug (NA) - Type A

Dimensions

CW-90B Bench Scale and 380 Indicator			
10 x 10 in			
A	19.56 in	E	9.43 in
B	10.20 in	F	4.25 in
C	14.02 in	G	10.20 in
D	13.36 in		

Note: 1 in = 25.4 mm

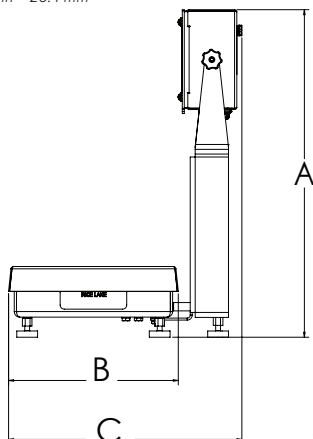

CW-90B with 380 indicator

12 x 12 in			
A	19.56 in	E	9.30 in
B	12.38 in	F	4.25 in
C	16.10 in	G	12.35 in
D	13.23 in		

Note: 1 in = 25.4 mm

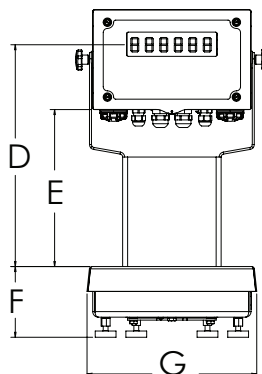

Standard Features

- Package includes scale with IP67 aluminum environmentally sealed load cell with an indicator and 12-inch column
- Factory calibrated with indicator setup and configured for 5,000 divisions
- Scale includes rubber feet to provide exceptional traction and avoid scratching surfaces along with removable top cover for ease of cleaning
- Standard RS-232 serial port for connecting to a variety of peripherals
- Powered by four alkaline C-cell batteries (not included) or external AC adapter (not included)

CW-90B Specifications

Load Cell, NTEP Certified:

IP67 aluminum, environmentally sealed

Scale Construction:

304 stainless steel

Maximum Overload:

180% to 200% depending on capacity

Overload Protection:

Five-point, independently adjusted

Scale Frame:

AISI304L, straight line finish, Ra=45 ± 10

Scale Cover:

AISI304L, straight line finish, Ra=45 ± 10

Cable Length:

34 in

Temperature:

Compensated:

14 °F to 104 °F (-10 °C to 40 °C)

Approvals:

NTEP 21-051, Class III 5,000 d
Measurement Canada AM-6184
NSF

Load cell is cFmus Approved

Warranty:

Two-year limited

380 Specifications

Power:

Battery: Lithium ion

Charger: 120 VAC internal

Battery Life:

45 hours, one 350 ohm load cell, no backlight

15 hours, four 350 ohm load cells, no backlight

10 hours, eight 350 ohm load cells, backlight

Communication Ports:

One full-duplex RS-232 (three-wire)

One USB 2.0

Display:

Six 1 in (25 mm) tall, LCD digits

Annunciators:

g, lb, t, tn, kg, oz, battery level, PT, LT, gross, zero, unstable, net

Keys/Buttons:

Five-tactile buttons

Rating/Material:

IP69K, 304 Stainless steel

Approvals:

NTEP 21-051

Measurement Canada AM-6184

CE

cULus

Warranty:

One-year limited on battery

Two-year limited on indicator and parts

Ready-n-Weigh Bench Scale System

CW-90B Bench Scale and 480/480 Plus Indicator Package

BENCH SCALES



Scale and Indicator Package

Standard Features

- Package includes scale with IP67 aluminum environmentally sealed load cell with an indicator and 12-inch column
- Factory calibrated with indicator setup and configured for 5,000 divisions
- Scale includes rubber feet to provide exceptional traction and avoid scratching surfaces along with removable top cover for ease of cleaning
- AC power 100 to 240 VAC
- Numeric keypad (480 Plus)
- Battery backed time and date
- Standard RS-232 serial ports for connecting to a variety of peripherals

CW-90B Specifications

Load Cell, NTEP Certified:
IP67 aluminum, environmentally sealed

Scale Construction:
304 stainless steel

Maximum Overload:
180% to 200% depending on capacity

Overload Protection:
Five-point, independently adjusted

Scale Frame:
AISI304L, straight line finish, Ra=45 ± 10

Scale Cover:
AISI304L, straight line finish, Ra=45 ± 10

Cable Length:
34 in

Temperature:
Compensated:
14 °F to 104 °F (-10 °C to 40 °C)

Approvals:
NTEP 12-123, Class III 5,000 d
Measurement Canada AM-5892C
CE
cULus

Warranty:
Two-year limited

480/480 Plus Specifications

Communication Ports:
Com 1: RS-232 full duplex
Com 2: RS-232 full duplex or 20 mA simplex, continuous
Both ports 1200, 2400, 4800, 9600, 19200, 38400 baud seven or eight data bits, even, odd or no parity

Display:
LED display 0.8 in (20 mm), six-digit, seven-segment

Status Annunciators:
Gross, net, center of zero, standstill, lb, kg, tare, preset tare

Keys/Buttons:
Flat membrane panel, embossed keys, tactile feel

Rating/Material:
Enclosure: NEMA Type 4X/IP66, heavy-gauge stainless steel

Approvals:
NTEP 12-123
Measurement Canada AM-5892C
CE Marked
UL/cUL Listed

Warranty:
Two-year limited

Approvals



Measurement
Canada
Approved



Dimensions

CW-90B Bench Scale and 480/480 Plus Indicator

10 × 10 in

A	19.50 in	E	9.25 in
B	10.25 in	F	4.25 in
C	14.53 in	G	10.25 in
D	13.25 in		

Note: 1 in = 25.4 mm

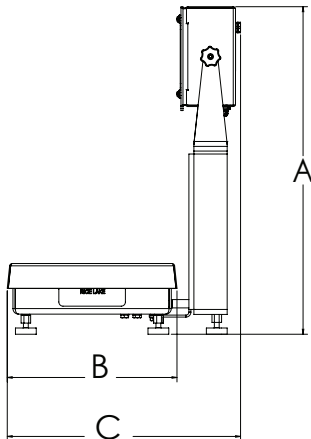

CW-90B with 480 indicator

12 × 12 in

A	19.50 in	E	9.25 in
B	12.25 in	F	4.25 in
C	16.53 in	G	12.25 in
D	13.25 in		

Note: 1 in = 25.4 mm

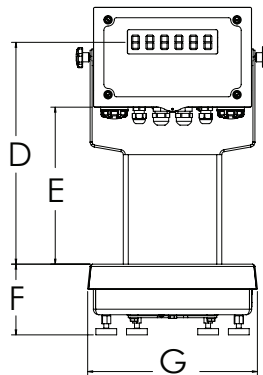

Ready-n-Weigh Bench Scale System

CW-90B Bench Scale and 480/480 Plus Indicator Package

CW-90B with 480 Package

Part #	Platform Capacity	Dimensions (L × W × H)	Est. Weight	Price
115 VAC, LED, US Plug-Type B				
201157	5 lb (2.5 kg)	10 × 10 × 4.25 in	24 lb	Consult
201158	10 lb (5 kg)	10 × 10 × 4.25 in	24 lb	Consult
201159	25 lb (10 kg)	10 × 10 × 4.25 in	24 lb	Consult
201160	25 lb (10 kg)	12 × 12 × 4.25 in	27 lb	Consult
201161	50 lb (25 kg)	12 × 12 × 4.25 in	27 lb	Consult
201162	100 lb (50 kg)	12 × 12 × 4.25 in	27 lb	Consult
90-264 VAC, LED, Euro Plug-Type E				
201169	5 lb (2.5 kg)	10 × 10 × 4.25 in	24 lb	Consult
201170	10 lb (5 kg)	10 × 10 × 4.25 in	24 lb	Consult
201171	25 lb (10 kg)	10 × 10 × 4.25 in	24 lb	Consult
201172	25 lb (10 kg)	12 × 12 × 4.25 in	27 lb	Consult
201173	50 lb (25 kg)	12 × 12 × 4.25 in	27 lb	Consult
201174	100 lb (50 kg)	12 × 12 × 4.25 in	27 lb	Consult

CW-90B with 480 Plus Package

Part #	Platform Capacity	Dimensions (L × W × H)	Est. Weight	Price
115 VAC, LED, Numeric keypad, US Plug-Type B				
201163	5 lb (2.5 kg)	10 × 10 × 4.25 in	24 lb	Consult
201164	10 lb (5 kg)	10 × 10 × 4.25 in	24 lb	Consult
201165	25 lb (10 kg)	10 × 10 × 4.25 in	24 lb	Consult
201166	25 lb (10 kg)	12 × 12 × 4.25 in	27 lb	Consult
201167	50 lb (25 kg)	12 × 12 × 4.25 in	27 lb	Consult
201168	100 lb (50 kg)	12 × 12 × 4.25 in	27 lb	Consult
90-264 VAC, LED, Numeric keypad, Euro Plug-Type E				
201175	5 lb (2.5 kg)	10 × 10 × 4.25 in	24 lb	Consult
201176	10 lb (5 kg)	10 × 10 × 4.25 in	24 lb	Consult
201177	25 lb (10 kg)	10 × 10 × 4.25 in	24 lb	Consult
201178	25 lb (10 kg)	12 × 12 × 4.25 in	27 lb	Consult
201179	50 lb (25 kg)	12 × 12 × 4.25 in	27 lb	Consult
201180	100 lb (50 kg)	12 × 12 × 4.25 in	27 lb	Consult



† US plug (NA) - Type B



†† Euro Plug - Type E

Ready-n-Weigh Bench Scale System

CW-90B Bench Scale and 482/482 Plus Indicator Package

BENCH SCALES



Approvals



Measurement
Canada
Approved



Dimensions

CW-90B Bench Scale and 482/482 Plus Indicator

10 × 10 in		
A	19.50 in	E 9.25 in
B	10.25 in	F 4.25 in
C	14.53 in	G 10.25 in
D	13.25 in	

Note: 1 in = 25.4 mm

12 × 12 in		
A	19.50 in	E 9.25 in
B	12.25 in	F 4.25 in
C	16.53 in	G 12.25 in
D	13.25 in	

Note: 1 in = 25.4 mm

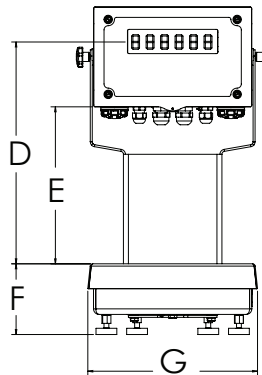
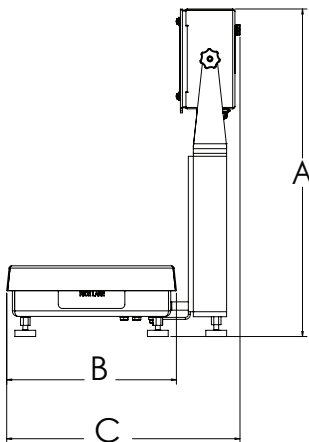

CW-90B with 482 indicator

Standard Features

- Package includes scale with IP67 aluminum environmentally sealed load cell with an indicator and 12-inch column
- Factory calibrated with indicator setup and configured for 5,000 divisions
- Scale includes rubber feet to provide exceptional traction and avoid scratching surfaces along with removable top cover for ease of cleaning
- AC power 100 to 240 VAC
- LCD backlit indicator display for a variety of environments
- Battery backed time and date
- Standard RS-232 serial ports for connecting to a variety of peripherals

CW-90B Specifications

Load Cell, NTEP Certified:

IP67 aluminum, environmentally sealed

Scale Construction:

304 stainless steel

Maximum Overload:

180% to 200% depending on capacity

Overload Protection:

Five-point, independently adjusted

Scale Frame:

AISI304L, straight line finish, Ra=45 ± 10

Scale Cover:

AISI304L, straight line finish, Ra=45 ± 10

Cable Length:

34 in

Temperature:

Compensated:

14 °F to 104 °F (-10 °C to 40 °C)

Approvals:

NTEP 12-123, Class III 5,000 d

Measurement Canada AM-5892C

CE

cULus

Warranty:

Two-year limited

482/482 Plus Specifications

Communication Ports:

Com 1: RS-232 full duplex

Com 2: RS-232 full duplex or 20 mA simplex, continuous

Both ports 1200, 2400, 4800, 9600, 19200, 38400 baud seven or eight data bits, even, odd or no parity

Display:

LCD backlit display, transmissive/transflective 0.8 in (20 mm), six-digit, seven-segment

Status Annunciators:

Gross, net, center of zero, standstill, lb, kg, tare, preset tare

Keys/Buttons:

Flat membrane panel, embossed keys, tactile feel

Rating/Material:

Enclosure: NEMA Type 4X/IP66, heavy-gauge stainless steel

Approvals:

NTEP 12-123

Measurement Canada AM-5892C

CE Marked

cULus Listed

Warranty:

Two-year limited

Ready-n-Weigh Bench Scale System

CW-90B Bench Scale and 482/482 Plus Indicator Package

BENCH SCALES

CW-90B with 482 Package

Part #	Platform Capacity	Dimensions (L × W × H)	Est. Weight	Price
115 VAC, LCD, US Plug-Type B				
201463	5 lb (2.5 kg)	10 × 10 × 4.25 in	24 lb	Consult
201464	10 lb (5 kg)	10 × 10 × 4.25 in	24 lb	Consult
201465	25 lb (10 kg)	10 × 10 × 4.25 in	24 lb	Consult
201466	25 lb (10 kg)	12 × 12 × 4.25 in	27 lb	Consult
201467	50 lb (25 kg)	12 × 12 × 4.25 in	27 lb	Consult
201468	100 lb (50 kg)	12 × 12 × 4.25 in	27 lb	Consult
90-264 VAC, LCD, Euro Plug-Type E				
201480	5 lb (2.5 kg)	10 × 10 × 4.25 in	24 lb	Consult
201485	10 lb (5 kg)	10 × 10 × 4.25 in	24 lb	Consult
201486	25 lb (10 kg)	10 × 10 × 4.25 in	24 lb	Consult
201487	25 lb (10 kg)	12 × 12 × 4.25 in	27 lb	Consult
201488	50 lb (25 kg)	12 × 12 × 4.25 in	27 lb	Consult
201489	100 lb (50 kg)	12 × 12 × 4.25 in	27 lb	Consult

CW-90B with 482 Package

Part #	Platform Capacity	Dimensions (L × W × H)	Est. Weight	Price
115 VAC, LCD, Numeric keypad, US Plug-Type B				
201469	5 lb (2.5 kg)	10 × 10 × 4.25 in	24 lb	Consult
201475	10 lb (5 kg)	10 × 10 × 4.25 in	24 lb	Consult
201476	25 lb (10 kg)	10 × 10 × 4.25 in	24 lb	Consult
201477	25 lb (10 kg)	12 × 12 × 4.25 in	27 lb	Consult
201478	50 lb (25 kg)	12 × 12 × 4.25 in	27 lb	Consult
201479	100 lb (50 kg)	12 × 12 × 4.25 in	27 lb	Consult
90-264 VAC, LCD, Numeric keypad, Euro Plug-Type E				
201490	5 lb (2.5 kg)	10 × 10 × 4.25 in	24 lb	Consult
201491	10 lb (5 kg)	10 × 10 × 4.25 in	24 lb	Consult
201492	25 lb (10 kg)	10 × 10 × 4.25 in	24 lb	Consult
201493	25 lb (10 kg)	12 × 12 × 4.25 in	27 lb	Consult
201494	50 lb (25 kg)	12 × 12 × 4.25 in	27 lb	Consult
201495	100 lb (50 kg)	12 × 12 × 4.25 in	27 lb	Consult



† US plug (NA) - Type B



** Euro Plug - Type E

Ready-n-Weigh Bench Scale System

CW-90B Bench Scale and 680 Indicator Package

BENCH SCALES



Approvals



Measurement
Canada
Approved



CW-90B with 680 Package

Part #	Platform Capacity	Dimensions (L × W × H)	Est. Weight	Price
115-230 VAC, LED, Numeric, US Plug-Type B				
201308	5 lb (2.5 kg)	10 × 10 × 4.25 in	24 lb	Consult
201309	10 lb (5 kg)	10 × 10 × 4.25 in	24 lb	Consult
201310	25 lb (10 kg)	10 × 10 × 4.25 in	24 lb	Consult
201311	25 lb (10 kg)	12 × 12 × 4.25 in	27 lb	Consult
201312	50 lb (25 kg)	12 × 12 × 4.25 in	27 lb	Consult
201313	100 lb (50 kg)	12 × 12 × 4.25 in	27 lb	Consult
115-230 VAC, LED, Numeric, Euro Plug-Type E				
201314	5 lb (2.5 kg)	10 × 10 × 4.25 in	24 lb	Consult
201315	10 lb (5 kg)	10 × 10 × 4.25 in	24 lb	Consult
201319	25 lb (10 kg)	10 × 10 × 4.25 in	24 lb	Consult
201320	25 lb (10 kg)	12 × 12 × 4.25 in	27 lb	Consult
201321	50 lb (25 kg)	12 × 12 × 4.25 in	27 lb	Consult
201322	100 lb (50 kg)	12 × 12 × 4.25 in	27 lb	Consult



* US plug (NA) - Type B



** Euro Plug - Type E

Dimensions

CW-90B Bench Scale and 680 Indicator			
10 × 10 in			
A	19.56 in	E	9.31 in
B	10.25 in	F	4.25 in
C	15.83 in	G	10.25 in
D	13.31 in		

Note: 1 in = 25.4 mm

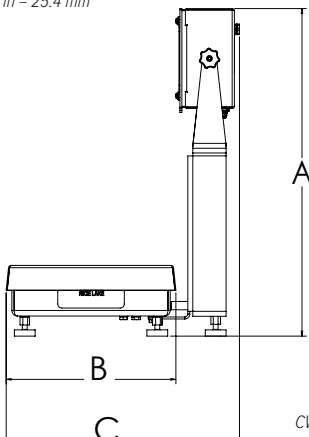

12 × 12 in			
A	19.56 in	E	9.31 in
B	12.25 in	F	4.25 in
C	16.83 in	G	12.25 in
D	13.31 in		

Note: 1 in = 25.4 mm

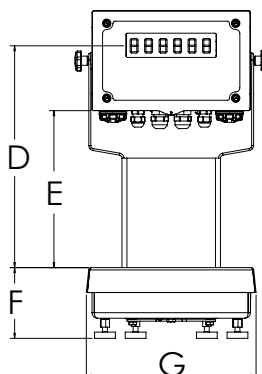

CW-90B with 680 indicator

Standard Features

- Package includes scale with IP67 aluminum environmentally sealed load cell with an indicator and 12-inch column
- Factory calibrated with indicator setup and configured for 5,000 divisions
- Scale includes rubber feet to provide exceptional traction and avoid scratching surfaces along with removable top cover for ease of cleaning
- AC power 100 to 240 VAC
- LCD backlit indicator display for a variety of environments
- Battery backed time and date
- Standard RS-232 serial ports for connecting to a variety of peripherals
- Ethernet TCP/IP comes standard

CW-90B Specifications

Load Cell, NTEP Certified:

IP67 aluminum, environmentally sealed

Scale Construction:

304 stainless steel

Maximum Overload:

180% to 200% depending on capacity

Overload Protection:

Five-point, independently adjusted

Scale Frame:

AISI304L, straight line finish, Ra=45 ± 10

Scale Cover:

AISI304L, straight line finish, Ra=45 ± 10

Cable Length:

34 in

Temperature:

Compensated:

14 °F to 104 °F (-10 °C to 40 °C)

Approvals:

NTEP 95-072, Class III 5,000 d

Measurement Canada AM-5082

NSF

Load cell is cFMus Approved

Warranty:

Two-year limited

680 Specifications

Communication Ports:

Two full-duplex RS-232

RS-485/422 (five -wire)

Micro USB (device)

Ethernet TCP/IP (10/100)

Display:

Seven 0.8 in tall, seven-segment digits

Annunciators:

Eight LED

Keys/Buttons:

Flat membrane panel, tactile feel

(18 buttons plus on/off)

Rating/Material:

IP69K (IP66 with RJ45)

AISI 304 stainless Steel

Approvals:

NTEP 19-021

Measurement Canada AM-6121C

cULus Listed

CE Marked

Warranty:

Two-year limited

Ready-n-Weigh Bench Scale System

CW-90XB Bench Scale and 380 Indicator Package

BENCH SCALES



Approvals



Measurement
Canada
Approved



CW-90XB with 380 Package

Part #	Capacity	Dimensions (L × W × H)	Est. Weight	Price
208543	5 lb (2.5 kg)	10 × 10 × 4.25 in	24 lb	Consult
208544	10 lb (5 kg)	10 × 10 × 4.25 in	24 lb	Consult
208545	25 lb (10 kg)	10 × 10 × 4.25 in	24 lb	Consult
208546	25 lb (10 kg)	12 × 12 × 4.25 in	27 lb	Consult
208547	50 lb (25 kg)	12 × 12 × 4.25 in	27 lb	Consult
208548	100 lb (50 kg)	12 × 12 × 4.25 in	27 lb	Consult

Options/Accessories

Part #	Description	Price
206433†	External AC adapter	Consult
204258	Real-time clock module	Consult



† US plug (NA) - Type A

Dimensions

CW-90XB Bench Scale and 380 Indicator			
10 × 10 in			
A	19.56 in	E	9.44 in
B	10.20 in	F	4.25 in
C	14.02 in	G	10.20 in
D	13.36 in		

Note: 1 in = 25.4 mm

12 × 12 in			
A	19.56 in	E	9.31 in
B	12.29 in	F	4.25 in
C	16.07 in	G	12.29 in
D	13.23 in		

Note: 1 in = 25.4 mm

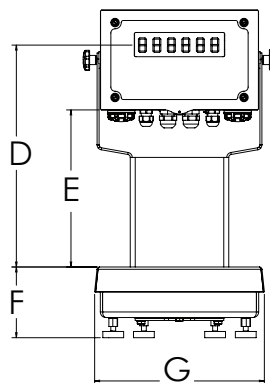
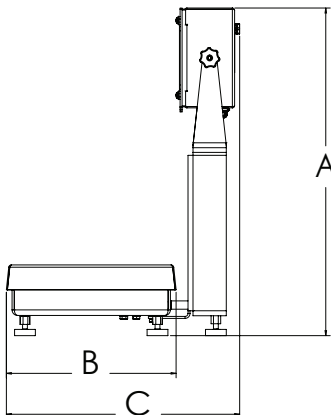

CW-90XB with 380 indicator

Standard Features

- Package includes scale with IP69K stainless steel hermetically sealed load cell with an indicator and 12-inch column
- Factory calibrated with indicator setup and configured for 5,000 divisions
- Scale includes rubber feet to provide exceptional traction and avoid scratching surfaces along with a removable top cover for ease of cleaning
- Powered by four alkaline C-cell batteries (not included) or external AC adapter (not included)
- Standard RS-232 serial port for connecting to a variety of peripherals

CW-90XB Specifications

Load Cell, NTEP Certified:

IP69K stainless steel and hermetically sealed

Scale Construction:

304 stainless steel

Maximum Overload:

180% to 200% depending on capacity

Overload Protection:

Five-point, independently adjusted

Scale Frame:

AISI304L, straight line finish, Ra=45 ± 10

Scale Cover:

AISI304L, straight line finish, Ra=45 ± 10

Cable Length:

34 in

Temperature:

Compensated:

14 °F to 104 °F (-10 °C to 40 °C)

Approvals:

NTEP 95-072, Class III 5,000 d

Measurement Canada AM-5082

Load cell is FM approved

Warranty:

Three-year limited (includes water ingress)

380 Specifications

Power:

Batteries: Four alkaline C-cell (not included)

Optional: 115/230 VAC to 12 VDC adapter

Battery Life:

100 hours on alkaline batteries with one 350 ohm load cell, no backlight

Communication Ports:

One RS-232 (three-wire)

One USB 2.0

Display:

Six 1-inch tall, LCD digits

Status Annunciators:

g, lb, t, tn, kg, oz, battery level, PT, LT, gross, zero, unstable, net

Keys/Buttons:

5 tactile buttons

Rating/Material:

Enclosure: IP66, 304 Stainless steel

Approvals:

NTEP 21-051

Measurement Canada AM-6184

CE Marked

cULus Listed

Warranty:

Two-year limited

Ready-n-Weigh Bench Scale System

CW-90XB Bench Scale and 480/480 Plus Indicator Package

BENCH SCALES



Scale and Indicator Package

Standard Features

- Package includes scale with IP69K stainless steel hermetically sealed load cell with an indicator and 12-inch column
- Factory calibrated with indicator setup and configured for 5,000 divisions
- Scale includes rubber feet to provide exceptional traction and avoid scratching surfaces along with removable top cover for ease of cleaning
- AC power 100 to 240 VAC
- Numeric keypad (480 plus)
- Battery backed time and date
- Standard RS-232 serial ports for connecting to peripherals

CW-90XB Specifications

Load Cell, NTEP Certified:

IP69K stainless steel and hermetically sealed

Scale Construction:

304 stainless steel

Maximum Overload:

180% to 200% depending on capacity

Overload Protection:

Five-point, independently adjusted

Scale Frame:

AISI304L, straight line finish, Ra = 45 ± 10

Scale Cover:

AISI304L, straight line finish, Ra = 45 ± 10

Cable Length:

34 in

Temperature:

Compensated:
14 °F to 104 °F (-10 °C to 40 °C)

CW-90XB Approvals:

NTEP CC 95-072, Class III 5,000 d
Measurement Canada AM-5082
Load cell is FM approved

Warranty:

Three-year limited (includes water ingress)

480/480 Plus Specifications

Communication Ports:

Com 1: RS-232 full duplex
Com 2: RS-232 full duplex or 20 mA simplex, continuous
Both ports 1200, 2400, 4800, 9600, 19200, 38400 baud seven or eight data bits, even, odd or no parity

Display:

LED display 0.8 in (20 mm), six-digit, seven-segment

Status Annunciators:

Gross, net, center of zero, standstill, lb, kg, tare, preset tare

Keys/Buttons:

Flat membrane panel, embossed keys, tactile feel

Rating/Material:

Enclosure: NEMA Type 4X/IP66, heavy-gauge stainless steel

Approvals:

NTEP 12-123
Measurement Canada AM-5892C
CE Marked
cULus Listed

Warranty:

Two-year limited

Approvals



Measurement
Canada
Approved



Dimensions

CW-90XB Bench Scale and 480/480 Plus Indicator

10 × 10 in

A	19.50 in	E	9.25 in
B	10.25 in	F	4.25 in
C	14.53 in	G	10.25 in
D	13.25 in		

Note: 1 in = 25.4 mm

12 × 12 in

A	19.50 in	E	9.25 in
B	12.25 in	F	4.25 in
C	16.53 in	G	12.25 in
D	13.25 in		

Note: 1 in = 25.4 mm

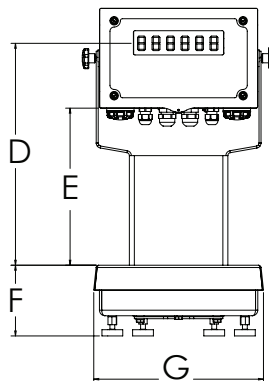
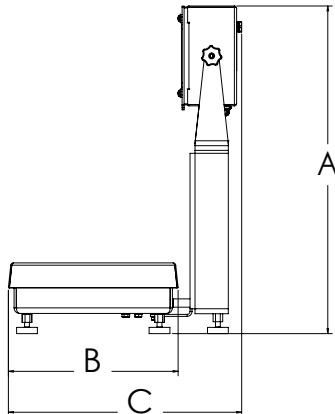

CW-90XB with 480 indicator

Ready-n-Weigh Bench Scale System

CW-90XB Bench Scale and 480/480 Plus Indicator Package

CW-90XB with 480 Package

Part #	Platform Capacity	Dimensions (L × W × H)	Est. Weight	Price
115 VAC, LED, US Plug-Type B				
201241	5 lb (2.5 kg)	10 × 10 × 4.25 in	24 lb	Consult
201242	10 lb (5 kg)	10 × 10 × 4.25 in	24 lb	Consult
201243	25 lb (10 kg)	10 × 10 × 4.25 in	24 lb	Consult
201244	25 lb (10 kg)	12 × 12 × 4.25 in	27 lb	Consult
201245	50 lb (25 kg)	12 × 12 × 4.25 in	27 lb	Consult
201246	100 lb (50 kg)	12 × 12 × 4.25 in	27 lb	Consult
90-264 VAC, LED, Euro Plug-Type E				
201254	5 lb (2.5 kg)	10 × 10 × 4.25 in	24 lb	Consult
201255	10 lb (5 kg)	10 × 10 × 4.25 in	24 lb	Consult
201257	25 lb (10 kg)	10 × 10 × 4.25 in	24 lb	Consult
201258	25 lb (10 kg)	12 × 12 × 4.25 in	27 lb	Consult
201259	50 lb (25 kg)	12 × 12 × 4.25 in	27 lb	Consult
201260	100 lb (50 kg)	12 × 12 × 4.25 in	27 lb	Consult

CW-90XB with 480 Plus Package

Part #	Platform Capacity	Dimensions (L × W × H)	Est. Weight	Price
115 VAC, LED, Numeric, US Plug-Type B				
201247	5 lb (2.5 kg)	10 × 10 × 4.25 in	24 lb	Consult
201248	10 lb (5 kg)	10 × 10 × 4.25 in	24 lb	Consult
201249	25 lb (10 kg)	10 × 10 × 4.25 in	24 lb	Consult
201250	25 lb (10 kg)	12 × 12 × 4.25 in	27 lb	Consult
201251	50 lb (25 kg)	12 × 12 × 4.25 in	27 lb	Consult
201253	100 lb (50 kg)	12 × 12 × 4.25 in	27 lb	Consult
90-264 VAC, LED, Numeric, Euro Plug-Type E				
201261	5 lb (2.5 kg)	10 × 10 × 4.25 in	24 lb	Consult
201262	10 lb (5 kg)	10 × 10 × 4.25 in	24 lb	Consult
201263	25 lb (10 kg)	10 × 10 × 4.25 in	24 lb	Consult
201264	25 lb (10 kg)	12 × 12 × 4.25 in	27 lb	Consult
201265	50 lb (25 kg)	12 × 12 × 4.25 in	27 lb	Consult
201266	100 lb (50 kg)	12 × 12 × 4.25 in	27 lb	Consult



* US plug (NA) - Type B



** Euro Plug - Type E

Ready-n-Weigh Bench Scale System

CW-90XB Bench Scale and 482/482 Plus Indicator Package

BENCH SCALES



Approvals



Measurement
Canada
Approved



Standard Features

- Package includes scale with IP69K stainless steel hermetically sealed load cell with an indicator and 12-inch
- Factory calibrated with indicator setup and configured for 5,000 divisions
- Scale includes rubber feet to provide exceptional traction and avoid scratching surfaces along with removable top cover for ease of cleaning
- AC power 100 to 240 VAC
- LCD backlit display suitable for a variety of environments
- Battery backed time and date
- Standard RS-232 serial ports for connecting to a variety of peripherals

Dimensions

CW-90XB Bench Scale and 482/482 Plus Indicator			
10 × 10 in			
A	19.50 in	E	9.25 in
B	10.25 in	F	4.25 in
C	14.53 in	G	10.25 in
D	13.25 in		

Note: 1 in = 25.4 mm

12 × 12 in			
A	19.50 in	E	9.25 in
B	12.25 in	F	4.25 in
C	16.53 in	G	12.25 in
D	13.25 in		

Note: 1 in = 25.4 mm

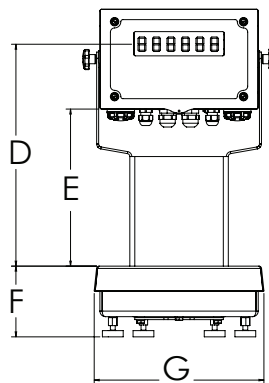
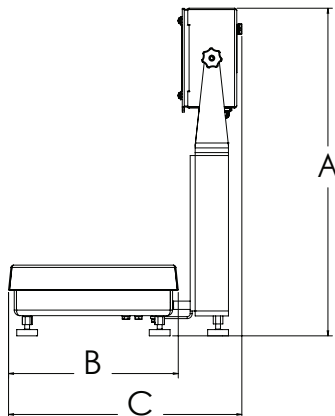

CW-90XB with 482 indicator

Specifications

Load Cell, NTEP Certified:
IP69K stainless steel and hermetically sealed

Scale Construction:
304 stainless steel

Maximum Overload:
180% to 200% depending on capacity

Overload Protection:
Five-point, independently adjusted

Scale Frame:
AISI304L, straight line finish, Ra=45 ± 10

Scale Cover:
AISI304L, straight line finish, Ra=45 ± 10

Cable Length:
34 in

Temperature:
Compensated:
14 °F to 104 °F (-10 °C to 40 °C)

Approvals:
NTEP CC 95-072, Class III 5,000 d
Measurement Canada AM-5082
Load cell is FM approved

Warranty:
Three-year limited (includes water ingress)

482/482 Plus Specifications

Communication Ports:
Com 1: RS-232 full duplex
Com 2: RS-232 full duplex or 20 mA simplex, continuous
Both ports 1200, 2400, 4800, 9600, 19200, 38400 baud seven or eight data bits, even, odd or no parity

Display:
LCD backlit display, transmissive/transflective
0.8 in (20 mm), six-digit, seven-segment

Status Annunciators:
Gross, net, center of zero, standstill, lb, kg, tare, preset tare

Keys/Buttons:
Flat membrane panel, embossed keys, tactile feel

Rating/Material:
Enclosure: NEMA Type 4X/IP66, heavy-gauge stainless steel

Approvals:
NTEP 12-123
Measurement Canada AM-5892C
CE Marked
cULus Listed

Warranty:
Two-year limited

Ready-n-Weigh Bench Scale System

CW-90XB Bench Scale and 482/482 Plus Indicator Package

CW-90XB with 482 Package

Part #	Platform Capacity	Dimensions (L × W × H)	Est. Weight	Price
115 VAC, LCD, US Plug-Type B				
201533	5 lb (2.5 kg)	10 × 10 × 4.25 in	24 lb	Consult
201534	10 lb (5 kg)	10 × 10 × 4.25 in	24 lb	Consult
201535	25 lb (10 kg)	10 × 10 × 4.25 in	24 lb	Consult
201536	25 lb (10 kg)	12 × 12 × 4.25 in	27 lb	Consult
201537	50 lb (25 kg)	12 × 12 × 4.25 in	27 lb	Consult
201538	100 lb (50 kg)	12 × 12 × 4.25 in	27 lb	Consult
90-264 VAC, LCD, Euro Plug-Type E				
201546	5 lb (2.5 kg)	10 × 10 × 4.25 in	24 lb	Consult
201547	10 lb (5 kg)	10 × 10 × 4.25 in	24 lb	Consult
201548	25 lb (10 kg)	10 × 10 × 4.25 in	24 lb	Consult
201549	25 lb (10 kg)	12 × 12 × 4.25 in	27 lb	Consult
201550	50 lb (25 kg)	12 × 12 × 4.25 in	27 lb	Consult
201551	100 lb (50 kg)	12 × 12 × 4.25 in	27 lb	Consult

CW-90XB with 482 Plus Package

Part #	Platform Capacity	Dimensions (L × W × H)	Est. Weight	Price
115 VAC, LCD, Numeric, US Plug-Type B				
201539	5 lb (2.5 kg)	10 × 10 × 4.25 in	24 lb	Consult
201541	10 lb (5 kg)	10 × 10 × 4.25 in	24 lb	Consult
201542	25 lb (10 kg)	10 × 10 × 4.25 in	24 lb	Consult
201543	25 lb (10 kg)	12 × 12 × 4.25 in	27 lb	Consult
201544	50 lb (25 kg)	12 × 12 × 4.25 in	27 lb	Consult
201545	100 lb (50 kg)	12 × 12 × 4.25 in	27 lb	Consult
90-264 VAC, LCD, Numeric, Euro Plug-Type E				
201552	5 lb (2.5 kg)	10 × 10 × 4.25 in	24 lb	Consult
201553	10 lb (5 kg)	10 × 10 × 4.25 in	24 lb	Consult
201554	25 lb (10 kg)	10 × 10 × 4.25 in	24 lb	Consult
201555	25 lb (10 kg)	12 × 12 × 4.25 in	27 lb	Consult
201556	50 lb (25 kg)	12 × 12 × 4.25 in	27 lb	Consult
201557	100 lb (50 kg)	12 × 12 × 4.25 in	27 lb	Consult



* US plug (NA) - Type B



** Euro Plug - Type E

Ready-n-Weigh Bench Scale System

CW-90XB Bench Scale and 680 Indicator Package

BENCH SCALES



Approvals



Measurement
Canada
Approved



CW-90XB with 680 Package

Part #	Platform Capacity	Dimensions (L × W × H)	Est. Weight	Price
115-230 VAC, LED, Numeric, US Plug-Type B				
201409	5 lb (2.5 kg)	10 × 10 × 4.25 in	24 lb	Consult
201410	10 lb (5 kg)	10 × 10 × 4.25 in	24 lb	Consult
201411	25 lb (10 kg)	10 × 10 × 4.25 in	24 lb	Consult
201412	25 lb (10 kg)	12 × 12 × 4.25 in	27 lb	Consult
201413	50 lb (25 kg)	12 × 12 × 4.25 in	27 lb	Consult
201414	100 lb (50 kg)	12 × 12 × 4.25 in	27 lb	Consult
115-230 VAC, LED, Numeric, Euro Plug-Type E				
201415	5 lb (2.5 kg)	10 × 10 × 4.25 in	24 lb	Consult
201416	10 lb (5 kg)	10 × 10 × 4.25 in	24 lb	Consult
201417	25 lb (10 kg)	10 × 10 × 4.25 in	24 lb	Consult
201418	25 lb (10 kg)	12 × 12 × 4.25 in	27 lb	Consult
201419	50 lb (25 kg)	12 × 12 × 4.25 in	27 lb	Consult
201420	100 lb (50 kg)	12 × 12 × 4.25 in	27 lb	Consult



† US plug (NA) - Type B



†† Euro Plug - Type E

Dimensions

CW-90XB Bench Scale and 680 Indicator		
10 × 10 in		
A	19.56 in	E 9.31 in
B	10.25 in	F 4.25 in
C	15.83 in	G 10.25 in
D	13.31 in	

Note: 1 in = 25.4 mm

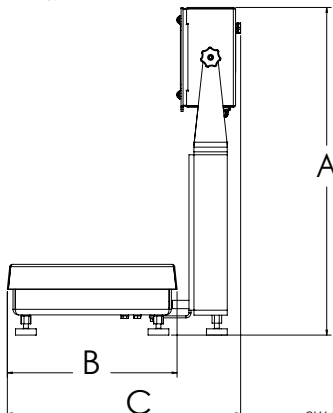

12 × 12 in		
A	19.56 in	E 9.31 in
B	12.25 in	F 4.25 in
C	16.83 in	G 12.25 in
D	13.31 in	

Note: 1 in = 25.4 mm

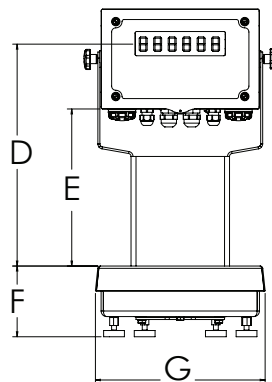

CW-90XB with 680 indicator

Standard Features

- Package includes scale with IP69K stainless steel hermetically sealed load cell with an indicator and 12-inch column
- Factory calibrated with indicator setup and configured for 5,000 divisions
- Scale includes rubber feet to provide exceptional traction and avoid scratching surfaces along with removable top cover for ease of cleaning
- AC power 100 to 240 VAC
- Full numeric keypad
- LED display suitable for a variety of environments
- Battery backed time and date
- Standard RS-232 serial ports for connecting to a variety of peripherals
- Ethernet TCP/IP

CW-90XB Specifications

Load Cell, NTEP Certified:

IP69K stainless steel and hermetically sealed

Scale Construction:

304 stainless steel

Maximum Overload:

180% to 200% depending on capacity

Overload Protection:

Five-point, independently adjusted

Scale Frame:

AISI304L, straight line finish, Ra = 45 ± 10

Scale Cover:

AISI304L, straight line finish, Ra = 45 ± 10

Cable Length:

34 in

Temperature:

Compensated:

14 °F to 104 °F (-10 °C to 40 °C)

Approvals:

NTEP CC 95-072, Class III 5,000 d

Measurement Canada AM-5082

Load cell is FM approved

Warranty:

Three-year limited (includes water ingress)

680 Specifications

Communication Ports:

Two RS-232 (three-wire)

RS-485/422 (two-wire or four-wire)

Micro USB (device)

Ethernet TCP/IP (10/100)

Display:

Seven 0.8-inch tall, seven-segment digits

Status Annunciators:

Eight LED annunciators

Keys/Buttons:

Flat membrane panel, tactile feel
(18 buttons plus ON/OFF)

Rating/Material:

Rating: IP69K (IP66 with RJ45)

Material: AISI 304 stainless steel

Approvals:

NTEP 19-021

Measurement Canada AM-6121C

cULus Listed

CE Marked

Warranty:

Two-year limited