

Rice Lake VS-35



Model Rice Lake VS-35

Standard Features

- Two wheels for portability
- Dual ramp
- Vacuum-formed, ribbed platform
- Push-button LCD display
- Motiontrap™ movement compensation technology
- Unit of measure toggle or locking
- Communication via USB
- Tare function
- Hold function
- Factory calibrated
- Easy to store, folded depth is 11.75 in

Specifications

- Capacity:**
1,000 × 0.2 lb (450 × 0.1 kg)
- Platform Dimensions Without Ramps:**
(W × L × H)
32.0 × 29.5 × 2.4 in
- Power:**
9 VDC, provided by six AA alkaline batteries (included) or AC adapter (optional)
- Battery Type:**
Six AA alkaline (included)
- Battery Use:**
25 hours continuous use with batteries
Automatic power-off can be configured
- Operating Temperature:**
50 °F to 104 °F (14 °C to 40 °C)

Display:
5-digit LCD display, 0.75 in (1.9 mm) digit height

Approvals:
c-Met, E113986

Warranty:
Two-year limited

COMPANION
ANIMAL SCALES

Approvals



Part Number/Price

Part #	Model #	Capacity	Price
204404	Rice Lake VS-35	1,000 lb × 0.2 lb (450 kg × 0.1 kg) with USB	Consult

Shipping Weight

Part #	Model #	L (in)	W (in)	H (in)	Package Wgt. (lb)	Dim Wgt. (lb)	Shipping Wgt. (lb)
204404	Rice Lake VS-35	51	42	14	102	216	216

Options/Accessories

Part #	Description	Price
220767	Heavy-duty mat	Consult
79074	Cable, USB 6 ft USB-A (male) to USB-B (male)	Consult
217091	Cable, Communication DB9 (female) to RJ45 (male), 4 conductor	Consult
186830	Cable, RS232 scale to printer, 6 ft, 25-pin D-Sub (male) to RJ45	Consult

Dimensions

	Inches	Centimeters
A	48.5	123.2
B	32.0	81.3
C	2.4	6.1
D	9.3	23.6
E	38.0	96.5
F	45.0	114.3

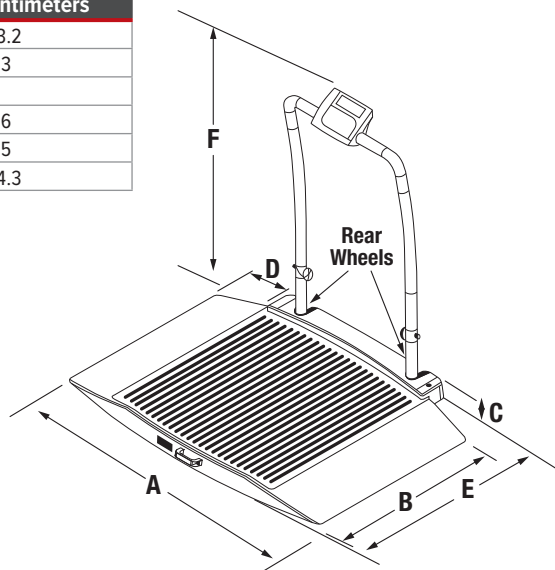

Optional heavy-duty mat