



Picture is a representation of actual product.

Approvals



Order Information

Load Rating	Part #	Est. Weight	Price
35 ft Cable			
25,000 lb	32702	7 lb	Consult
50,000 lb	32701	7 lb	Consult
100,000 lb	32700	15 lb	Consult
200,000 lb	32699	28 lb	Consult
80 ft Cable			
200,000 lb	197788	30 lb	Consult

Dimensions

Rated Capacity	A	B	D	F	G	H	L-DEPTH
lb/in							
25,000 to 50,000	3.00	3.25	6.00	0.40	1.25	1/2-20 UNF	0.31
100,000	4.00	5.00	6.00	0.51	2.31	3/4-16 UNF	0.56
200,000	6.00	7.25	17.00	1.04	3.13	3/4-16 UNF	0.75

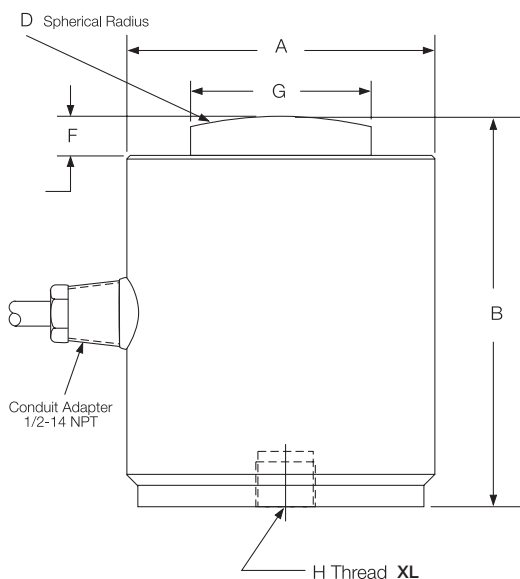

Interchangeable Products

- VPG® REVERE
- CSP** page 265
- VPG® SENSORTRONICS®
- 65088-1000**
- VPG® REVERE
- 692B**
- HOWE RICHARDSON®
- 244699-000X**
- STREETER AMET®
- 3760XXX**

Weigh Module Available

- RICE LAKE WEIGHING SYSTEMS
- MagnaMount™** page 80

Specifications

- Full Scale Output:**
2.0 mV/V
- Output Resistance:**
475.2 to 484.8 ohm
- Input Resistance:**
445.5 to 454.5 ohm
- Material/Finish:**
Stainless steel
- Temperature:**
Compensated:
14 °F to 104 °F (-10 °C to 40 °C)
Operating:
0 °F to 150 °F (-18 °C to 65 °C)
- Seal Type:**
Welded-seal, IP67
- Safe Overload:**
150% full scale
- Rated Excitation:**
5 to 10 VDC (15 V maximum)
- Combined Error:**
0.03% full scale
- Non-repeatability:**
0.01% full scale
- Insulation Resistance:**
1,000 megohm
- Deflection at Capacity:**
25,000 to 50,000 lb: 0.003 in
100,000 to 125,000 lb: 0.006 in
- Cable Length:**
35 ft
80 ft
- Cable Diameter:**
0.305 in
Polyurethane jacket
- Cable Color Code:**
Green +Excitation
Black -Excitation
White +Signal
Red -Signal
Orange Shield
- Warranty:**
Two-year limited
- Approvals:**
NTEP 95-140

RICE LAKE
LOAD CELLS