

ROCKER COLUMN
RLSCA-50K

Stainless Steel, Welded Seal, NTEP Certified 1:10,000 Class III Multiple Cell, IP67



Picture is a representation of actual product.

Approvals



Order Information

Load Rating	Part #	Est. Weight	Price
50,000 lb*	68918	7 lb	Consult
Replacement Parts			
Replacement load cup set upper and lower included	85433	1 lb	Consult
Replacement O-ring	92988	1 lb	Consult/each

*Load cell supplied with load cups

Dimensions

Rated Capacity	A	B	C	D	F	H	I	J	K
50,000 lb/in	1.46	7.75	7.25	2.82	1.70	0.50	0.25	1.48	2.50

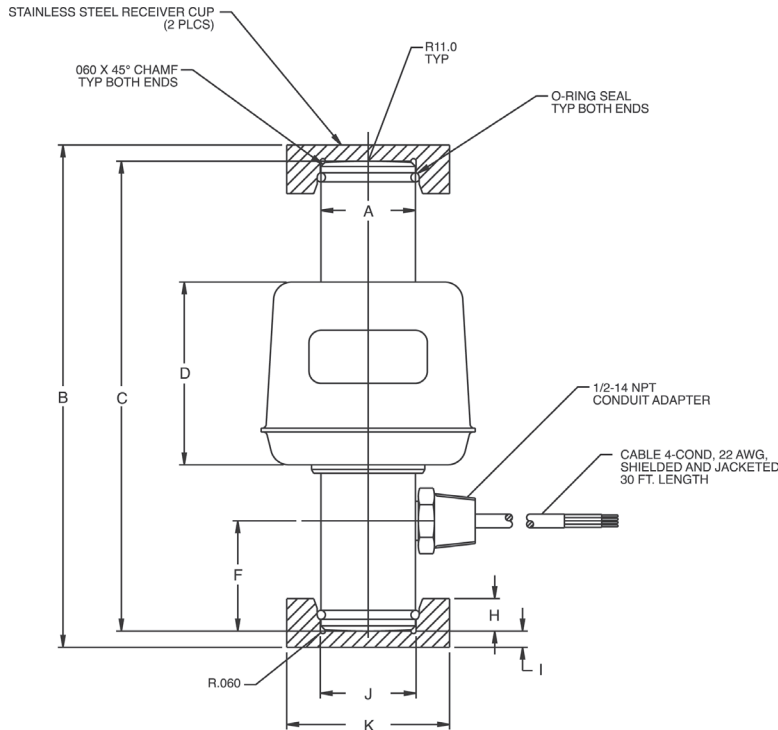

Interchangeable Products

CARDINAL®
SCA-50K

Specifications

- Full Scale Output:**
2 mV/V nominal
- Output Resistance:**
1,050 (± 10) ohm
- Input Resistance:**
1,100 to 1,500 ohm
- Material/Finish:**
Stainless steel
- Temperature:**
Compensated:
14 °F to 104 °F (-10 °C to 40 °C)
Operating:
0 °F to 150 °F (-18 °C to 65 °C)
- Seal Type:**
Welded-seal, IP67
- Safe Overload:**
150% full scale
- Rated Excitation:**
5 to 10 VDC (15 V maximum)
- Combined Error:**
0.025% full scale
- Non-repeatability:**
0.01% full scale
- Insulation Resistance:**
1,000 megohm
- Cable Length:**
30 ft
- Cable Diameter:**
0.200 in
Polyurethane jacket
- Cable Color Code:**
Green +Excitation
Black -Excitation
Red +Signal
White -Signal
- Warranty:**
Two-year limited
- Approvals:**
NTEP 01-073
cFMus

RICE LAKE
LOAD CELLS