

SINGLE POINT  
**RLSP4**

Aluminum, Environmentally Sealed, NTEP Certified 1:5,000 Class III Single Cell, IP66



Picture is a representation of actual product.

Approvals



Order Information

Load Rating	Part #	Est. Weight	Price
<b>NTEP Certified</b>			
7 kg	91725	2 lb	Consult
10 kg	91726	2 lb	Consult
15 kg	91727	2 lb	Consult
20 kg	91728	2 lb	Consult
30 kg	91729	2 lb	Consult
50 kg	91730	2 lb	Consult
75 kg	91731	2 lb	Consult
100 kg	91732	2 lb	Consult

Dimensions

Rated Capacity	A	B	C	D	E	F	G	H	I
kg/mm									
5 to 100	150.3	25.4	39.9	19.1	19.1	19.1	33.8	99.6	11.4

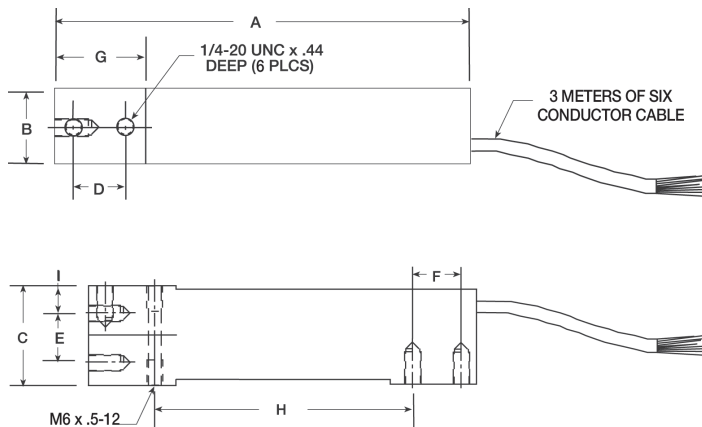

Interchangeable Products

HBK®  
**SP4M**..... page 228

Specifications

- Full Scale Output:**  
2.0 mV/V
- Output Resistance:**  
350 (± 3) ohm
- Input Resistance:**  
350 ohm
- Material/Finish:**  
Anodized aluminum
- Temperature:**  
Compensated:  
14 °F to 104 °F (-10 °C to 40 °C)  
Operating:  
0 °F to 150 °F (-18 °C to 65 °C)
- Seal Type:**  
Environmentally sealed, IP66
- Safe Overload:**  
150% full scale
- Rated Excitation:**  
5 to 10 VDC (15 V maximum)
- Combined Error:**  
0.02% full scale
- Insulation Resistance:**  
5,000 megohm
- Deflection at Capacity:**  
0.4 mm
- Cable Length:**  
10 ft
- Cable Diameter:**  
0.19 in PVC jacket
- Cable Color Code:**  
Green +Excitation  
Black -Excitation  
Red +Signal  
White -Signal  
Blue +Sense  
Brown -Sense  
Yellow Shield
- Max Platform Size:**  
5 to 10 kg: 12 × 12 in  
15 to 30 kg: 18 × 18 in  
50 to 100 kg: 24 × 24 in
- Warranty:**  
Two-year limited
- Approvals:**  
FM  
NTEP 05-114

RICE LAKE  
LOAD CELLS