

RoughDeck® HP

Caster SENDit Portability Frames, NTEP

FLOOR SCALES



Standard Features

- Wireless connection from scale to operator display
- Excitation to the load cell(s) provided by the transmitter, not the indicator
- Each transmitter/receiver set is individually paired and will not interfere with another set
- Transmitter excitation voltage: +4.8 VDC, 16 × 350 ohm or 32 × 700 ohm load cells
- Estimated battery life of 100 hours
- Two set -points with red/green display for operator verification
- Optional audible alarm

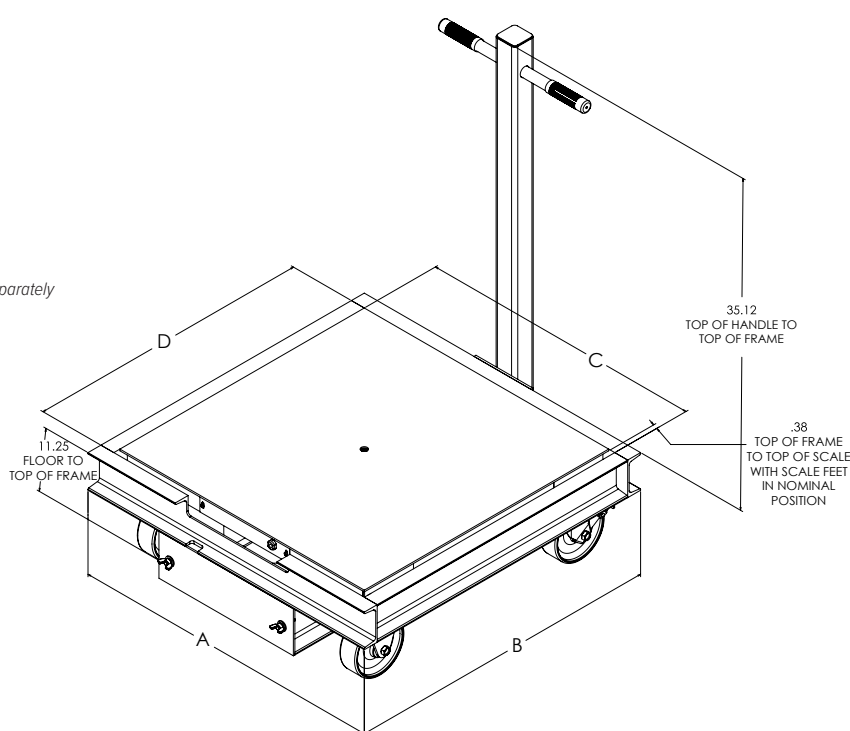

Approvals



Part Number/Price

Part #	Size (W × L)	Est. Weight	Price
Roughdeck HP Caster Portability Frame			
210902	2.5 × 2.5 ft, up to 5,000 lb capacity, two rigid forged steel caster on front, two swivel forged steel caster on back with drawer for SENDit, frame only	315 lb	Consult
210903	3 × 3 ft, up to 5,000 lb capacity, two rigid forged steel caster on front, two swivel forged steel caster on back with drawer for SENDit, frame only	330 lb	Consult
210904	4 × 4 ft, up to 5,000 lb capacity, two rigid forged steel caster on front, two swivel forged steel caster on back with drawer for SENDit, frame only	355 lb	Consult
210905	4 × 4 ft, up to 10,000 lb capacity, two rigid forged steel caster on front, two swivel forged steel caster on back with drawer for SENDit, frame only	355 lb	Consult
SENDit Wireless Electronics Kit			
210899	Sendit wireless load cell interface kit, NTEP, includes one 8004HD display	-	Consult

Options/Accessories

Part #	Description	Price
162173	Battery, 6 V SLA	Consult

Dimensions

Scale Size	2.5 x 2.5 ft	3 x 3 ft	4 x 4 ft
A	33.92 in	39.92 in	51.92 in
B	33.92 in	39.92 in	51.92 in
C	30.75 in	36.75 in	48.75 in
D	30.75 in	36.75 in	48.75 in

Note: 1 in=25.4 mm