

RoughDeck® QC-X

Quick Clean Extreme Lift Floor Scale with Solid Plate Base

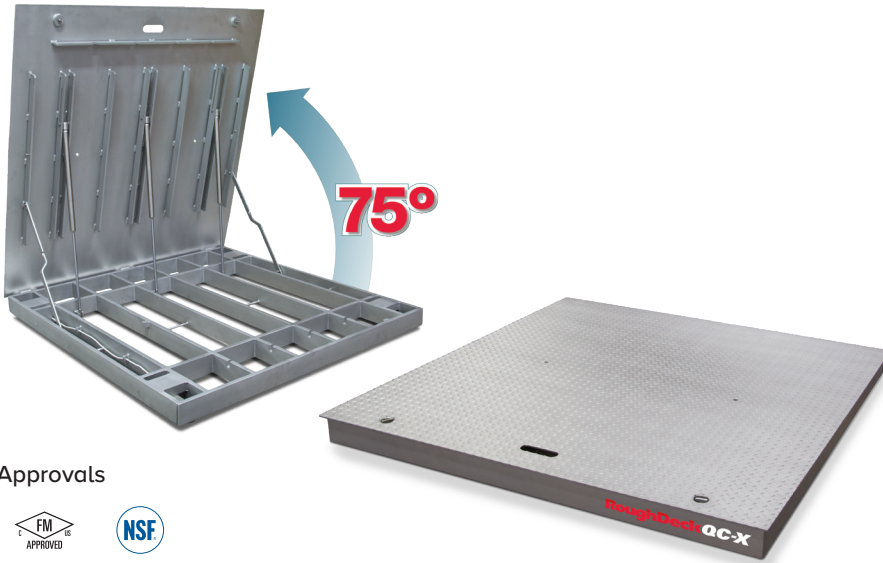

Approvals



Part Number/Price

Part #	Size (W × L × H)	Capacity	Est. Weight	Price
Smooth Top Plate				
175686	4 ft × 4 ft × 4.625 in	5,000 lb (2,500 kg)	650 lb	Consult
175689	4 ft × 4 ft × 4.625 in	10,000 lb (5,000 kg)	650 lb	Consult
175694	5 ft × 5 ft × 4.625 in	5,000 lb (2,500 kg)	950 lb	Consult
175695	5 ft × 5 ft × 4.625 in	10,000 lb (5,000 kg)	950 lb	Consult
Diamond Tread Top Plate				
175688	4 ft × 4 ft × 4.625 in	5,000 lb (2,500 kg)	650 lb	Consult
175690	4 ft × 4 ft × 4.625 in	10,000 lb (5,000 kg)	650 lb	Consult
175696	5 ft × 5 ft × 4.625 in	5,000 lb (2,500 kg)	950 lb	Consult
175697	5 ft × 5 ft × 4.625 in	10,000 lb (5,000 kg)	950 lb	Consult

Options/Accessories

Part #	Description	Price	
28740	Floor stand for indicator, 36.3 in high, stainless steel	Consult	
18778	Floor anchor plates, stainless steel (set of two)	Consult	
Pit Frames (L × W)			
175691	4 × 4 ft	Consult	
175698	5 × 5 ft	Consult	
Ramps (Diamond Treadplate Standard)		Ramp Angle of Incline	
175692	4 ft × 3 ft × 4.625 in, fits hinge/handhole side	7.0°	Consult
175693	4 ft × 4 ft × 4.625 in, fits hinge/handhole side	5.2°	Consult
175699	5 ft × 3 ft × 4.625 in, fits hinge/handhole side	7.0°	Consult
175700	5 ft × 4 ft × 4.625 in, fits hinge/handhole side	5.2°	Consult
178840	4 ft × 3 ft × 4.625 in, fits side of scale	7.0°	Consult
178849	4 ft × 4 ft × 4.625 in, fits side of scale	5.2°	Consult
178850	5 ft × 3 ft × 4.625 in, fits side of scale	7.0°	Consult
178851	5 ft × 4 ft × 4.625 in, fits side of scale	5.2°	Consult

Standard Features

- Rugged washdown design, rigid 304 stainless steel frame constructed with continuous welds
- Meets HACCP requirements
- Manual drop-in-place safety bars
- Four stainless steel, hermetically sealed, IP69K shear beam load cells with 30 ft cables
- 20 ft of SURVIVOR® EL147HE hostile environment cable for connecting junction box to indicator
- Remote junction box can be mounted up to 15 ft away
- 1/4 in top plate
- Four adjustable stainless steel SUREFOOT™ support feet
- Top plate opens 75 degrees
- Tool-less top plate lock downs
- Top plate available with a smooth deck or diamond treadplate
- Two 1/2-20 NF threaded eyebolt holes for lifting scale into pit frame

Specifications

End Load Capacity:

- 100% full scale at 5,000 lb
- 80% full scale at 10,000 lb

Cable Length:

- 20 ft (6.1 m) for connecting junction box to indicator

Scale Weldment:

- AISI304L, glass bead blasted for even appearance

Junction Box:

- TuffSeal® JB4SS stainless steel, NEMA Type 4X junction box with signal trim card

Welding:

- Continuous

Threaded Eyebolt:

- Two 1/2-20 NF threaded eyebolt holes for lifting scale into pit frame

Warranty (limited):

- Weldment: Five-year
- Load cells: Two-year
- All other components: One-year

Approvals:

- cFMus
- NSF

FLOOR SCALES

RoughDeck® QC-X

Quick Clean Extreme Lift Floor Scale with Solid Plate Base

FLOOR SCALES



Ramp fits side of scale



Ramp fits hinge/handhole side

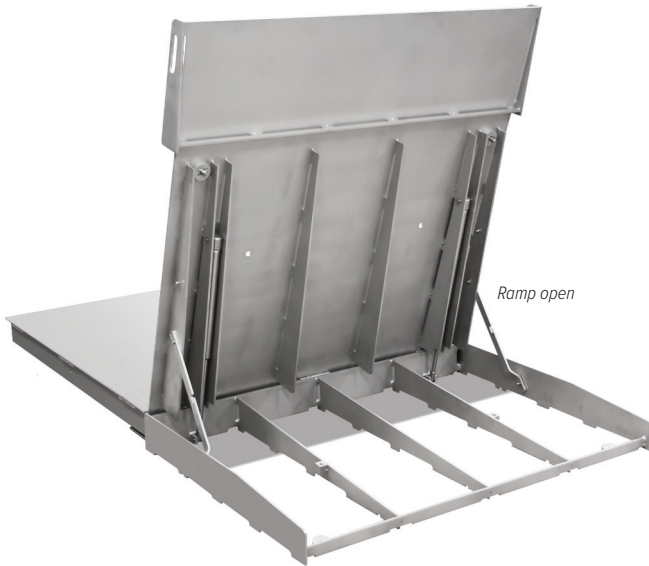

Ramp open

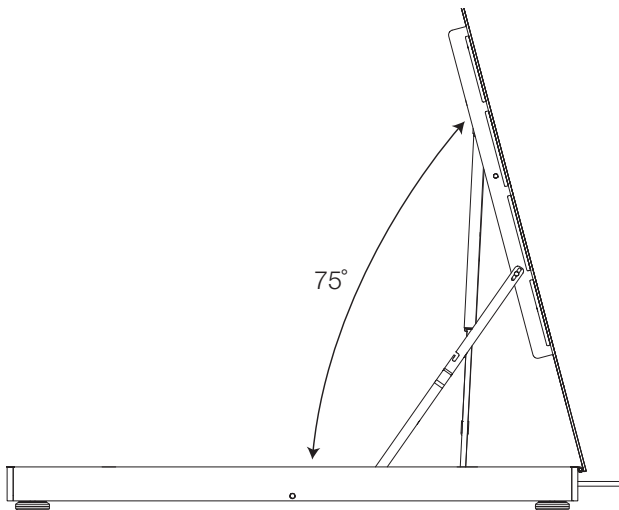

Upright position

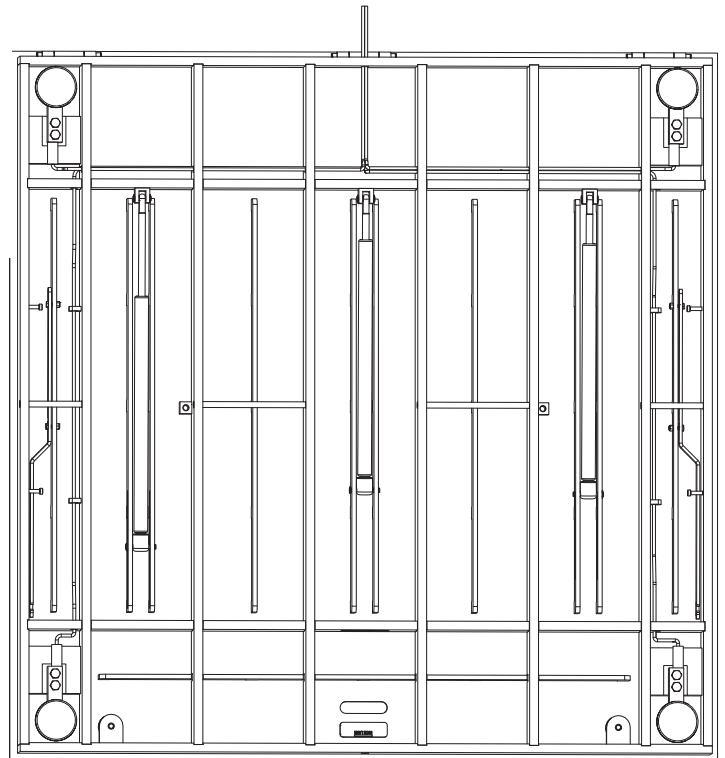

Underdeck View