



# SD-1150-WP

## DIALYSIS WHEELCHAIR SCALE

The Summit™ SD-1150-WP dialysis wheelchair scale is designed to accommodate the unique needs of dialysis patients. It is designed to be pit-mounted flush with the floor for multipurpose weighing. Its heavy-duty handrail enhances patient safety and convenience, and is positioned to remain clear of wheelchairs. Convenient keypad tare reduces errors and increases efficiency.

### FEATURES

- Package includes scale, pit frame, handrail and indicator
- Large LCD display
- Antimicrobial keypad
- Heavy-duty mild steel construction
- Live handrail for accuracy and patient safety
- Unit of measure toggle or locking
- Motiontrap™ movement compensation technology
- EMR capable
- Serial and USB data communication ports
- Bluetooth® BLE 4.0 available, part number selectable
- Tare function
- Hold function
- BMI (body mass index) function
- Factory calibrated

### SPECIFICATIONS

**Capacity:**  
1,000 × 0.2 lb (450 × 0.1 kg)

**Platform Dimensions:**  
(L × W × H)  
36.00 × 36.00 × 3.00 in

**Power:**  
9 VDC, provided by six AA alkaline batteries (included) or AC adapter (optional)

**Battery Type:**  
Six AA alkaline (included)

**Battery Use:**  
25 hours continuous use with batteries  
Automatic power-off can be configured

**Display:**  
5-digit LCD display, 0.75 in (1.9 cm) digit height

**Cable Length:**  
10 ft (3.1 m) cable between scale base and indicator

**Temperature:**  
Operating:  
50 °F to 104 °F (10 °C to 40 °C)

**Warranty:**  
Two-year limited





## WHEELCHAIR SCALE

MODEL	CAPACITY	COMMUNICATION	PART #
SD-1150-WP	1,000 × 0.2 lb (450 × 0.1 kg)	USB	150707
SD-1150-WPBLE	1,000 × 0.2 lb (450 × 0.1 kg)	Bluetooth® BLE 4.0	205978

## OPTIONS

DESCRIPTION	PART #
9 VDC adapter, 120 V/230 V auto switching*	133077
9 VDC adapter, 230 V**	102508
Epson TM-U220 tape printer	81076
Cable, RS232 scale to printer, 6 ft, 25-pin D-Sub (male) to RJ45	186830

\*NEMA 1-15 Plug  \*\*CEE 7/16 Plug 

## SHIPPING WEIGHT

MODEL #	PART #	L (IN)	W (IN)	H (IN)	PACKAGE WGT. (LB)	DIM WGT. (LB)	SHIPPING WGT. (LB)
SD-1150-WP	150707	40	39	15	246	169	246
SD-1150-WPBLE	205978	40	39	15	246	169	246

\*Pallet weight and dimensions are included in shipping weights

## DIMENSIONS

	INCHES	CENTIMETERS		INCHES	CENTIMETERS
<b>A</b>	36.00	91.4	<b>E</b>	31.50	80.0
<b>B</b>	36.00	91.4	<b>F</b>	37.00	94.0
<b>C</b>	3.00	7.6	<b>G</b>	35.50	90.2
<b>D</b>	28.5	72.4			

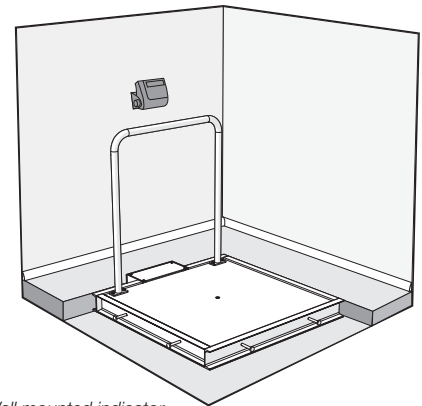

Wall mounted indicator, cable enclosed in customer supplied conduit.

