

Picture is a representation of actual product

Approvals



Available upon request

Order Information

Load Rating	Part #	Est. Weight	Price
1 kg	40680	2 lb	Consult
3 kg	40681	2 lb	Consult
5 kg	40682	2 lb	Consult
10 kg	40683	2 lb	Consult
15 kg	40684	2 lb	Consult
20 kg	40685	2 lb	Consult
30 kg	40686	2 lb	Consult
50 kg	40687	2 lb	Consult
75 kg	40688	2 lb	Consult
100 kg	40689	2 lb	Consult

Dimensions

Rated Capacity	A	H	L	L1	L2	L3	L4	L5	L6	W	W1	T
kg/mm												
1 to 30	20.0	39.0	150.0	19.0	100.0	25.0	34.0	19.0	34.0	40.0	1.0	1/4-20 UNC
50 to 100	25.2	39.0	150.0	19.0	100.0	25.0	34.0	19.0	34.0	40.0	1.0	1/4-20 UNC

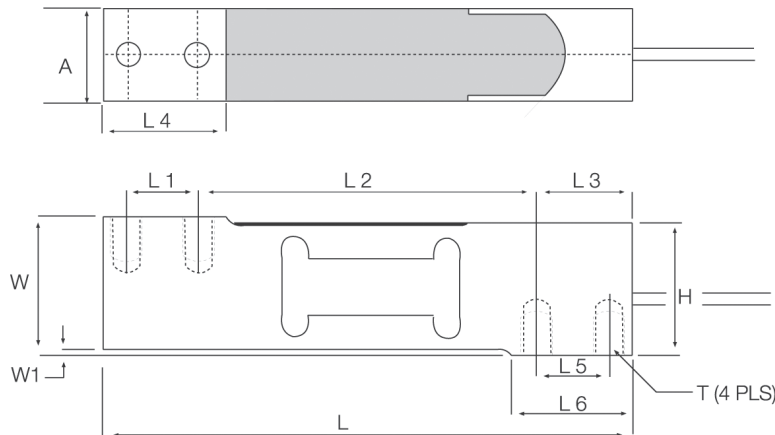

Interchangeable Products

- RICE LAKE WEIGHING SYSTEMS
RL1042.....page 163
- RICE LAKE WEIGHING SYSTEMS
RL42018A.....page 171

Specifications

- Full Scale Output:**
2.0 mV/V
- Output Resistance:**
350 (± 3) ohm
- Input Resistance:**
415 (± 15) ohm
- Material/Finish:**
Aluminum
- Temperature:**
Compensated:
14 °F to 104 °F (-10 °C to 40 °C)
Operating:
0 °F to 150 °F (-18 °C to 65 °C)
- Seal Type:**
Environmentally sealed, IP66
- Safe Overload:**
150% full scale
- Rated Excitation:**
5 to 10 VDC (15 V maximum)
- Combined Error:**
0.02% full scale
- Insulation Resistance:**
2,000 megohm
- Deflection at Capacity:**
0.015 in
- Cable Length:**
10 ft
- Cable Diameter:**
0.200 in PVC jacket
- Cable Color Code:**
Green +Excitation
Black -Excitation
Red +Signal
White -Signal
Blue +Sense
Brown -Sense
- Max Platform Size:**
16 × 16 in
- Warranty:**
One-year limited
- Approvals:**
NTEP
cFMus
OIML (Available upon request)

VPG®
TEDEA-HUNTLEIGH®