

Weigh/Check In Kiosk

Automated Truck Scale System



Shown with PN 176452

Standard Features

Weigh/Check In Kiosk

- 920i® HMI with sun shield
- Four serial ports
- 120 VAC
- Two option slots for 920i option cards
- One-year warranty

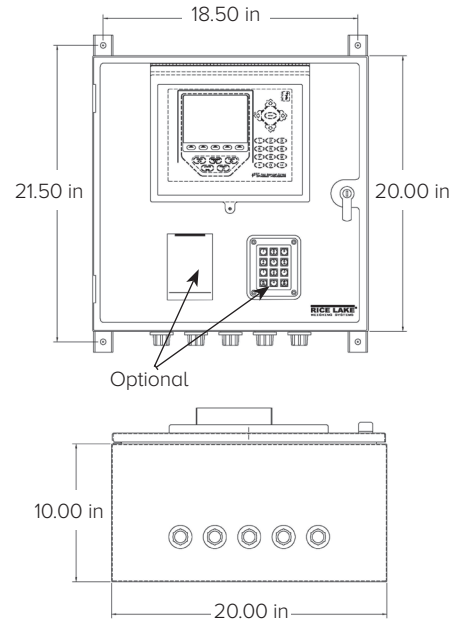

Part Numbers/Price

Part #	Description	Price
153353	Check-in kiosk with 920i HMI, 20 × 20 × 12 in painted mild steel enclosure	Consult

Options/Accessories

Part #	Description	Price
119691	Vandal-proof 12-key keypad	Consult
176452	HID smart card reader	Consult
119692	88 key, panel mount Qwerty style keyboard	Consult
119693	200 watt heater	Consult
119689	Kiosk option, A/D single-channel, includes DIN rail and terminals	Consult
119690	Kiosk option, A/D dual-channel, includes DIN rail and terminals	Consult

AUTOMATED TICKETING

Printer Kiosk

Direct Thermal Printer Kiosk



PN 112836

Standard Features

Direct Thermal Printer Kiosk

- Custom America VKP80II receipt printer
- Slide door access to ticket
- 8 in paper roll
- 1 year warranty

Specifications

Line Voltages:

115 or 230 VAC

Frequency:

50/60 Hz

Power Consumption:

0.5 amps (depending on options)

Fusing:

3.15 amps circuit breaker

Printer Communication Ports:

RS-232 or Ethernet

Temperature:

Storage:
14 °F to 158 °F (-10 °C to 70 °C)

Humidity:

0 to 95% relative humidity

Warranty:

One-year limited

