

Second Generation Single A/D Scale Card Installation

The Second Generation Single A/D Scale Card (PN 220026) provides a single scale channel. The 1280 can support up to eight scales. The configuration of each scale is stored both on the card and in the indicator's memory. The CPU board will rewrite the calibration to the A/D scale card when replacing or swapping installed cards.

There are two generations of scale cards, this document describes the second generation scale card. See [Table 1](#) for a comparison between the scale card generations:

Card Generation	Channels	Card PN	Identifying Characteristics
First Generation	Single	164085	green circuit board, slide switch, one scale channel
Second Generation	Single	220026	blue circuit board, push button, one scale channel

Table 1. Scale Card Identification Information



Manuals are available from Rice Lake Weighing Systems at www.ricelake.com/manuals

Warranty information is available at www.ricelake.com/warranties

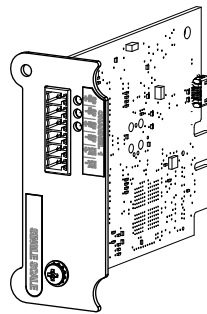

Figure 1. Single A/D Scale Card Kit

The included parts kit contains items used for installation of the card. Items listed for stud grounding of the shields pertain to the panel mount enclosure. See the 1280 technical manual (PN 167659) for more information on grounding the shield.

Part No.	Description	Qty
14621	Nut, Kep 6-32NC HEX (used for stud grounding)	1
15130	Washer, Lock NO 6 Type A (used for stud grounding)	1
153883	Connector, 6 Pos Screw Terminal (interface connector)	1
15631	Cable Tie, 3 inch Nylon (secures cable in panel mount installation)	4
53075	Clamp, Ground Cable Shield (used for stud grounding)	1
171801	Ferrite Core, Snap on	1
94422	Label, Capacity .40 x 5.00	

Table 2 Parts Kit (PN 163782)

WARNING: Always disconnect power before opening the indicator. Option card is not hot swappable.

CAUTION: Use a wrist strap to ground yourself and protect components from electrostatic discharge (ESD) when working inside the indicator enclosure.

1. Open the indicator as instructed in the 1280 technical manual.
2. Remove a slot cover plate from the controller assembly to open a slot for the card.
3. Remove protective tape from pins J3 on the option card prior to installation. Make sure the pins are clean of sticky residue by carefully wiping with a cloth dampened with rubbing alcohol.

NOTE: To use a 6-wire load cell cable (with sense wires), remove jumpers JP1 and JP2 before installing cord to J1. To use a 4-wire connection, leave jumpers JP1 and JP2 on.

4. Align the card to the slot; the screw hole in the faceplate of the card should align with the screw hole on the controller assembly.
5. Slide the card into the top and bottom grooves of the slot. Push the card until it is securely seated in the back plane.
6. Secure with screw 4-40 NC x 1/4 (provided).
7. Route the cable through the cord grip to attach the cable from the scale to the A/D scale card.
8. Wire the load cell cable from the scale to the connector (from the parts kit) for J1 as shown in Figure 2 and Table 3.
9. When connections are complete, install load cell connector on the A/D scale card.

NOTE: A sealing clip can be installed over the connector to provide a hardware seal that allows access while preventing removal of the scale card and connector.

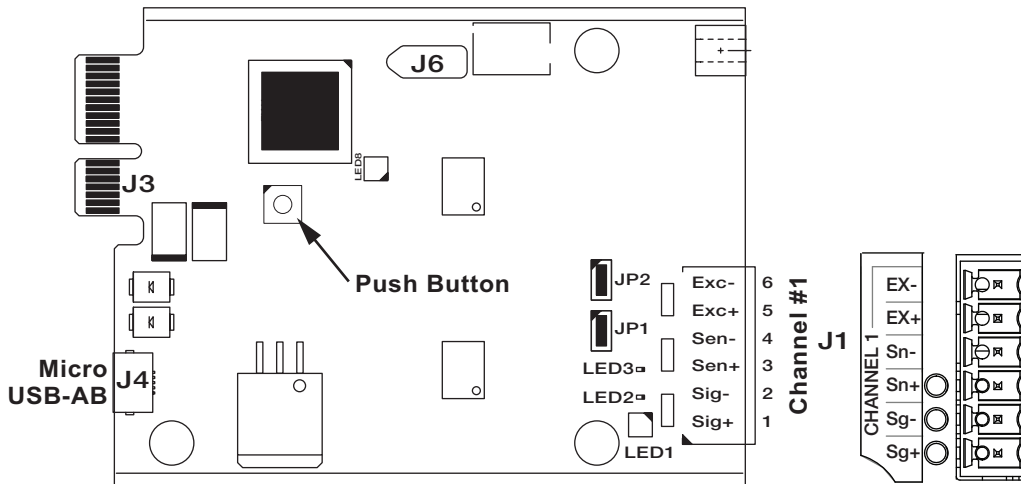



Figure 2. Single-Channel A/D Card

J1	Channel #1
Pin 1	SIG+
Pin 2	SIG-
Pin 3	SENSE+
Pin 4	SENSE-
Pin 5	EXC+
Pin 6	EXC-

For 6-wire load cell connections to connector J1, remove jumpers JP1 and JP2.

Table 3 Pin Assignments

 **NOTE:** The slot of the controller assembly selected for the installation of the card determines the scale channels that can be associated to a scale number.



Slot 1 = Slot 1 Channel 1Slot 1 Channel 2	Slot 4 = Slot 4 Channel 1Slot 4 Channel 2
Slot 2 = Slot 2 Channel 1Slot 2 Channel 2	Slot 5 = Slot 5 Channel 1Slot 5 Channel 2
Slot 3 = Slot 3 Channel 1Slot 3 Channel 2	Slot 6 = Slot 6 Channel 1Slot 6 Channel 2

Table 4. Associated Scale Channels

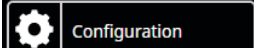
Use cable ties from the parts kit to secure loose cables inside the enclosure as needed. Ensure no excess or loose cable is left inside the enclosure.

10. Ground the shield cable using the ground washer in the metal cord grip, or the grounding stud on the enclosure using cable clamp included in the parts kit. See the 1280 technical manual for more information.
11. Tighten cord grips. Ensure cord grip nut is also tight.
12. Reassemble and power the indicator.
13. Press  on the weigh mode screen. The **Main Menu** displays.
14. Press  for access to the Configuration menu.

 **NOTE:** Access to the Configuration menu may be restricted. Refer to the 1280 technical manual for more information.

15. Select  to enter the scales menu and configure the single A/D scale card.
16. Select the scale number (1-8) to be configured from the selection field drop down list.
17. Select  and set the scale to **Analog Load Cell Scale**. The **Select Scale Hardware** screen displays.
18. Select the slot and channel desired.
19. See the 1280 technical manual for calibration instructions.

LED Status Indicators

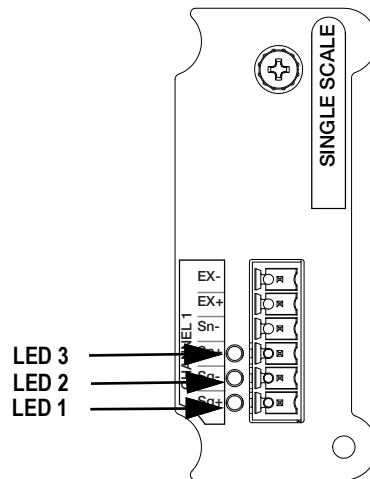

Figure 3. Single A/D Scale Card Faceplate

LED	Status
1	Green flashing indicates card is working. Red indicates it is faulty
2	Green indicates a load cell is connected and configured correctly
3	Not Used

Table 4 LED Status Lights

Specifications

Excitation Voltage	10 ± 0.5 VDC, 16 x 350Ω or 32 x 700Ω load cells per A/D card
Sense Amplifier	Differential amplifier with 4- and 6-wire sensing
Analog Signal Input Range	-60 mV to 60 mV
Analog Signal Sensitivity	0.3 uV/grad minimum @ 7.5 Hz 1.0 uV/grad typical @ 120 Hz 4.0 uV/grad typical @ 960 Hz
A/D Sample Rate	7.5-960 Hz, software selectable
Input Impedance	>35 MΩ typical
Internal Resolution	+/- 8388608 counts
Weight Display Resolution	9,999,999
Input Sensitivity	10 nV per internal count
System Linearity	±0.01% of full scale
Zero Stability	±150 nV/°C, maximum
Span Stability	± 3.5 ppm/°C, maximum
Input Voltage Differential	±800 mV referenced to earth ground
Input Overload	Load cell signal lines ±10 V continuous, ESD protected
RFI/EMI Protection	Signal, excitation and sense lines protected



© Rice Lake Weighing Systems Content subject to change without notice.

230 W. Coleman St. • Rice Lake, WI 54868 • USA USA: 800-472-6703 • International: +1-715-234-9171