

720TMi

Programmable Weight Indicator/Controller

720i Firmware Version 2

720iB (Batching) Firmware Version 1

Technical Manual



**Disponible
en Español**
Visite ricelake.com/spanish
para ver todos los materiales
RLWS disponibles en Español



RICE LAKE[®]
WEIGHING SYSTEMS

© Rice Lake Weighing Systems. All rights reserved.

Rice Lake Weighing Systems® is a registered trademark of
Rice Lake Weighing Systems.

All other brand or product names within this publication are trademarks or
registered trademarks of their respective companies.

All information contained within this publication is, to the best of our knowledge, complete and
accurate at the time of publication. Rice Lake Weighing Systems reserves the right to make
changes to the technology, features, specifications and design of the equipment without notice.

The most current version of this publication, software, firmware and all other product
updates can be found on our website:

www.ricelake.com

Revision History

This section tracks and describes manual revisions for awareness of major updates.

Revision	Date	Description
F	July 25, 2022	Revision history established; added additional UL safety guidelines and made some general formatting updates
G	November 2, 2022	Added panel mount installation instructions, cord grip diameter ranges and torque specs; updated Revolution calibration and indicator connection procedures
H	July 12, 2023	General updates
I	August 5, 2024	Added setpoint routine examples

Table i. Revision Letter History



Technical training seminars are available through Rice Lake Weighing Systems. Course descriptions and dates can be viewed at www.ricelake.com/training or obtained by calling 715-234-9171 and asking for the training department.

Contents

1.0	Introduction	7
1.1	Safety	7
1.2	Overview	8
1.2.1	Onboard Features	8
1.2.2	Option Cards	8
1.2.3	Enclosures	8
1.2.4	Support Applications	8
1.3	FCC Compliance	8
1.4	System Configurations	9
1.5	Options	9
1.5.1	DC Power Supplies	9
2.0	Operation	10
2.1	Operating Modes	11
2.1.1	Weigh Mode	11
2.1.2	Setup Mode	11
2.2	Indicator Operations	11
2.2.1	Display Menu	11
2.2.2	Toggle Gross/Net Mode	11
2.2.3	Toggle Units	11
2.2.4	Zero Scale	12
2.2.5	Acquire Tare	12
2.2.6	Enter Tare Value	12
2.2.7	Remove Stored Tare Value	12
2.2.8	Print Ticket	12
2.2.9	Select Auxiliary Print Format	12
2.2.10	Accumulator Functions	12
2.3	Softkey Operations	13
3.0	Installation	14
3.1	Unpacking and Assembly	14
3.2	Enclosure Disassembly	14
3.3	Cable Connections	15
3.3.1	Load Cells	15
3.3.2	Serial Communications	16
3.3.3	Digital I/O	17
3.3.4	Detached Display Module (DDM)	17
3.4	Installing Option Cards	18
3.5	Slot Assignments	19
3.6	Grounding Cables/Wires	19
3.6.1	Stripping Cables	20
3.7	Enclosure Reassembly	20
3.8	Panel Mount Installation	21
3.8.1	Panel Mount Cutout Dimensions	21
3.8.2	Panel Mount Display Installation	21
3.8.3	Panel Mount Controller Installation	22
3.8.4	Panel Mount Cable Connections	22
3.9	Legal for Trade Sealing	23
3.9.1	Security Sealing	23
3.10	CPU Board Removal	24



Rice Lake continually offers web-based video training on a growing selection of product-related topics at no cost. Visit www.ricelake.com/webinars

3.11	Battery Replacement	24
3.11.1	Replacement Procedure	24
3.12	Replacement Parts and Assembly Drawings	25
3.12.1	Universal Model	25
3.12.2	Panel Mount Display	29
3.12.3	Panel Mount Controller	30
4.0	Configuration	32
4.1	Configuration Methods	32
4.1.1	Revolution Configuration	32
4.1.2	Serial Command Configuration	33
4.1.3	Front Panel Configuration	33
4.1.4	Multi-Range and Multi-Interval Scales	33
4.2	Menu Structures and Parameter Descriptions	34
4.2.1	Menu Navigation	35
4.2.2	SCALES Menu	36
4.2.3	SERIAL Menu	46
4.2.4	FEATURE Menu	50
4.2.5	PFORMAT Menu	55
4.2.6	DIG I/O Menu	56
4.2.7	ALGOUT Menu	58
4.2.8	FLDBUS Menu	59
4.2.9	VERS Menu	59
5.0	Calibration	60
5.1	Gravity Compensation	60
5.2	Front Panel Calibration	61
5.3	Serial Command Calibration	62
5.4	Revolution Calibration	62
6.0	Using Revolution	63
6.1	Connecting to the Indicator	63
6.2	Installing Software Upgrades	64
7.0	Print Formatting	65
7.1	Print Formatting Commands	65
7.2	Default Print Formats	67
7.3	Customizing Print Formats	68
7.3.1	Using Revolution	68
7.3.2	Using the Front Panel	69
7.3.3	Using Serial Commands	70
8.0	Truck Modes	71
8.1	Features	71
8.2	Using the Truck Modes	71
8.3	Using the Truck Regs Display	72
8.4	Weigh-In Procedure	72
8.5	Weigh-Out Procedure	72
8.6	Single-Transaction Tare Weights and IDs	73
8.7	Using the Advance Mode	73
8.7.1	Advance Mode Menus	77
9.0	Setpoints	79
9.1	Batch and Continuous Setpoints	79



Technical training seminars are available through Rice Lake Weighing Systems. Course descriptions and dates can be viewed at www.ricelake.com/training or obtained by calling 715-234-9171 and asking for the training department.

9.2	Setpoint Menu Parameters	81
9.3	Batch Operations	91
9.4	Batching Examples	93
9.4.1	Example 1	93
9.4.2	Example 2	94
10.0	Using ProAction PCEE	95
10.1	Writing a PCE Process	95
10.2	Performing a Merge	96
10.3	Pause, Reset, and Restore Process	96
10.4	Revolution	96
10.5	Setting Up a Simple Three-Step Fill	97
10.6	Helpful Hints	98
10.7	Database Information	99
11.0	Serial Commands	100
11.1	The Serial Command Set	100
11.1.1	Key Press Commands	100
11.1.2	Reporting Commands	101
11.1.3	Clear and Reset Commands	101
11.1.4	Parameter Setting Commands	101
11.1.5	Normal Mode Commands	107
11.1.6	Batching Control Commands	108
11.1.7	Digital I/O Control Commands	108
11.1.8	Database Commands	108
11.1.9	Advance Mode EDP Commands	112
12.0	Appendix	113
12.1	Troubleshooting	113
12.1.1	Option Card Diagnostic Errors	113
12.1.2	Using the HARDWARE Command	114
12.1.3	Diagnostic Boot Procedure	114
12.1.4	Onboard Diagnostic LEDs	115
12.1.5	Using the XE Serial Command	115
12.2	Regulatory Mode Functions	116
12.3	Serial Scale Interface	117
12.4	Local/Remote Operation	118
12.5	Custom Stream Formatting	119
12.6	Data Formats	121
12.6.1	Continuous Output Serial Data Format	121
12.6.2	Demand Output Serial Data Format	121
12.6.3	RS-485 Data Formats	121
12.7	Digital Filtering	122
12.8	Conversion Factors for Secondary Units	123
12.9	Audit Trail Support	125
12.10	Display Module Configuration	125
12.10.1	DDM Communications Ports	125
12.11	Alibi Tracking	126
12.12	Dimension Drawings	127
12.13	Printed Information	128
13.0	Compliance	129
14.0	Specifications	131



Rice Lake continually offers web-based video training on a growing selection of product-related topics at no cost. Visit www.ricelake.com/webinars

1.0 Introduction

This manual is intended for use by service technicians responsible for installing and servicing 720i digital weight indicators. This manual applies to Version 2.00 of the 720i indicator software and Version 1.01 of the 720i batching indicator software. Configuration and calibration of the indicator can be accomplished using the Revolution configuration utility, serial commands or the indicator front panel keys. See [Section 4.1 on page 32](#) for information about configuration methods.



Manuals are available from Rice Lake Weighing Systems at www.ricelake.com/manuals

Warranty information is available at www.ricelake.com/warranties

1.1 Safety

Safety Definitions:



DANGER: Indicates an imminently hazardous situation that, if not avoided, will result in death or serious injury. Includes hazards that are exposed when guards are removed.



WARNING: Indicates a potentially hazardous situation that, if not avoided, could result in serious injury or death. Includes hazards that are exposed when guards are removed.



CAUTION: Indicates a potentially hazardous situation that, if not avoided, could result in minor or moderate injury.



IMPORTANT: Indicates information about procedures that, if not observed, could result in damage to equipment or corruption to and loss of data.

General Safety



Do not operate or work on this equipment unless this manual has been read and all instructions are understood. Failure to follow the instructions or heed the warnings could result in injury or death. Contact any Rice Lake Weighing Systems dealer for replacement manuals.



WARNING

Failure to heed could result in serious injury or death.

Ensure the power cord is disconnected from the outlet before opening the unit.

The socket/outlet must be near the equipment and must be easily accessible.

Fuses should only be replaced by qualified service personnel.

Ethernet port not intended for circuits that are subject to lightning or power faults.

Do not allow minors (children) or inexperienced persons to operate this unit.

Do not operate without the enclosure completely assembled.

Do not use for purposes other than weight taking.

Do not place fingers into slots or possible pinch points.

Do not use this product if any of the components are cracked.

Do not exceed the rated specification of the unit.

Do not allow minors (children) or inexperienced persons to operate this unit.

Do not operate without all shields and guards in place.

Do not make alterations or modifications to the unit.

Do not remove or obscure warning labels.

Do not use solvents or aggressive substances to clean the indicator.

Do not submerge.

1.2 Overview

The 720i is a single-channel programmable digital weight indicator/controller. The 720i can be loaded with PCE software or 720i batching software. Refer to [Section 9.0 on page 79](#) or [Section 10.0 on page 95](#) for further information on software choices.

1.2.1 Onboard Features

Features of the basic 720i include:

- Support for a single A/D or serial scale input
- Eight digital I/O channels on main board, each configurable as an input or an output
- Two serial ports on main board support duplex RS-232 up to 115200 bps; Port 2 supports RS-232 with hardware handshaking; Port 4 supports RS-232 and 20 mA communications
- Available in 115 VAC and 230 VAC North American and European versions
- Configurable print formats can be defined for up to 1000 characters each using the front panel, serial commands or Revolution; These formats are used to print gross or net weights, truck in/out weights, accumulator weights, alert messages and header information; Additional print formats can be created using 20 auxiliary print formats
- Seven truck modes to store and recall weights for gross, tare and net printing; The truck register contains fields for ID number, weight and the transaction time and date; Weights can be stored permanently or erased at the end of the transaction

1.2.2 Option Cards

The CPU board provides one slot for installing option cards. Available option cards include:

- Analog output card for 0–10 VDC or 0–20 mA tracking of gross or net weight values
- Dual-channel serial expansion card provides one RS-485 port or two ports for either RS-232 or 20 mA communications at up to 19200 bps
- 24-channel digital I/O expansion card
- Ethernet option card
- Bus interface cards for EtherNet/IP™, DeviceNet™, Allen-Bradley® Remote I/O, Profibus® DP networks and ControlNet™



NOTE: See [Section 1.4 on page 9](#) for part numbers of available option cards.

1.2.3 Enclosures

The 720i is available in universal (tilt-stand) and panel mount enclosures. Stainless steel enclosures are rated for NEMA Type 4X/IP66. This manual provides assembly drawings and replacement parts lists for the universal model; supplemental documentation provides information specific to the panel mount model ([Section 1.4 on page 9](#)).

1.2.4 Support Applications

In addition to Revolution, the 720i is supported by two Windows-based applications that extend its capabilities for batch control and database management. ProAction PCEE, or Process Control Engine Editor, provides functions similar to setpoint configuration for 720i-based batch control. ProAction DBE, the database editor, is a tool for creating, editing and managing databases in the 720i. Both applications are included on the 720i Toolkit CD.

1.3 FCC Compliance

United States

This equipment has been tested and found to comply with the limits for a Class A digital device, pursuant to Part 15 of the FCC Rules. These limits are designed to provide reasonable protection against harmful interference when the equipment is operated in a commercial environment. This equipment generates, uses and can radiate radio frequency energy and, if not installed and used in accordance with the instruction manual, may cause harmful interference to radio communications. Operation of this equipment in a residential area is likely to cause harmful interference in which case the user will be required to correct the interference at his own expense.

Canada

This digital apparatus does not exceed the Class A limits for radio noise emissions from digital apparatus set out in the Radio Interference Regulations of the Canadian Department of Communications.

Le présent appareil numérique n'émet pas de bruits radioélectriques dépassant les limites applicables aux appareils numériques de la Class A prescrites dans le Règlement sur le brouillage radioélectrique édicté par le ministère des Communications du Canada.

1.4 System Configurations

All models include a CPU board with one option card slot. The 720i is a single scale unit and cannot be upgraded to a multi-channel A/D. The 720 is provided with either the PCE firmware, which includes Truck In/Out programs or as Batching firmware for setpoint control.

System Model	Part No.
PCE Software	
Universal (Tilt Stand) Model, 115/230 VAC with PCE Software	101230
Universal (Tilt Stand) Model, 115/230 VAC, European, CEE 7/7 Power Cord with PCE Software	103459
Universal Model, 12–36 VDC, 25 W	107708
Panel Mount Model, 115/230 VAC (Power Cord Sold Separately) with PCE Software	101229
Panel Mount Model 115–230 VAC, CE/OIML	119116
Panel Mount Model, 12–24 VDC	107710
Batch Software	
Universal (Tilt Stand) Model, 115/230 VAC with 720i Batch Software	115447
Universal (Tilt Stand) Model, 115/230 VAC, European, CEE 7/7 Power Cord with 720i Batch Software	115448
Panel Mount Model, 115/230 VAC (Power Cord Sold Separately) with 720i Batch Software	115449

Table 1-1. 720i Model Part Numbers

1.5 Options

Most of the listed option cards are installed in the expansion card slot, J12. USB and Ethernet interface cards are installed in connector J11.

Option Card	Part No.
Single-channel Analog Output Card	67602
Dual Serial Port Expansion Card	67604
24-channel Digital I/O Expansion Card	67601
Ethernet Communications Card	71986
EtherNet/IP Communications Card	87803
DeviceNet Interface Card	68541
Allen-Bradley Remote I/O Interface Card	68539
Profibus DP Interface Card	68540
USB Interface Card	93245

Table 1-2. 720i Option Card Part Numbers

Relay racks are available for all 720i systems. Relays require an external enclosure. Consult factory for details.

1.5.1 DC Power Supplies

Consult factory for more information.

Option Card	Part No.
12–30 VDC Supply	97474
10–60 VDC Supply	99480

Table 1-3. 720i DC Power Supply Part Numbers

2.0 Operation

This section provides an overview of 720i Programmable HMI Indicator/Controller operation instructions.

The 720i universal model front panel consists of a 22-button keypad with an LCD display (Figure 2-1). The keys are grouped as four configurable softkeys, four scale function/navigation keys, **Menu** and **Print/Enter** keys, and numeric entry keys. The panel mount front panel consists of a 10-button keypad with an LCD display.

LCD display contrast can be adjusted by selecting the **Contrast Adj** function from the system menu.

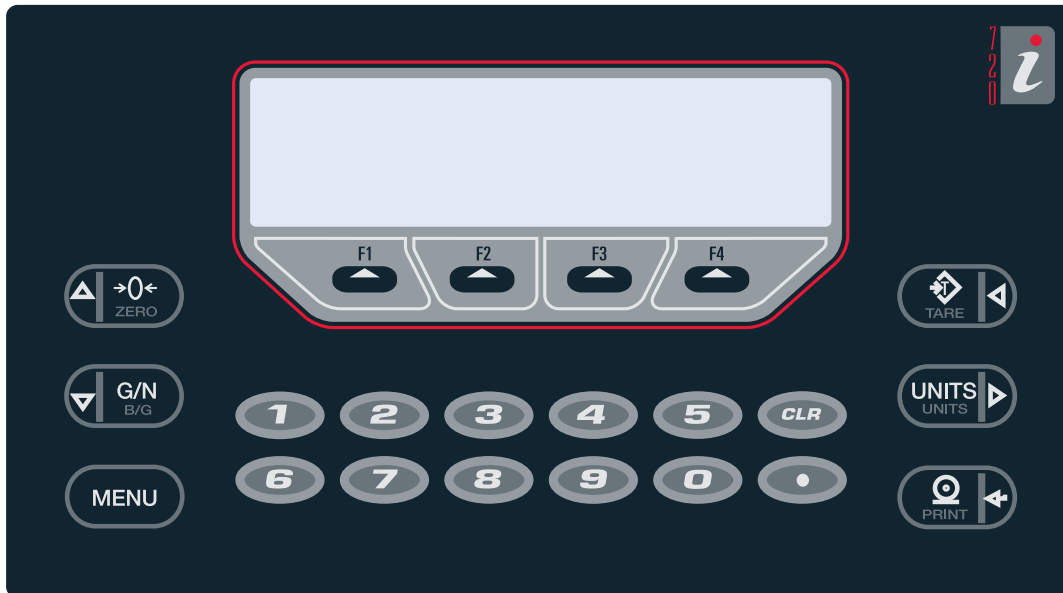

Figure 2-1. Universal Mount Front Panel

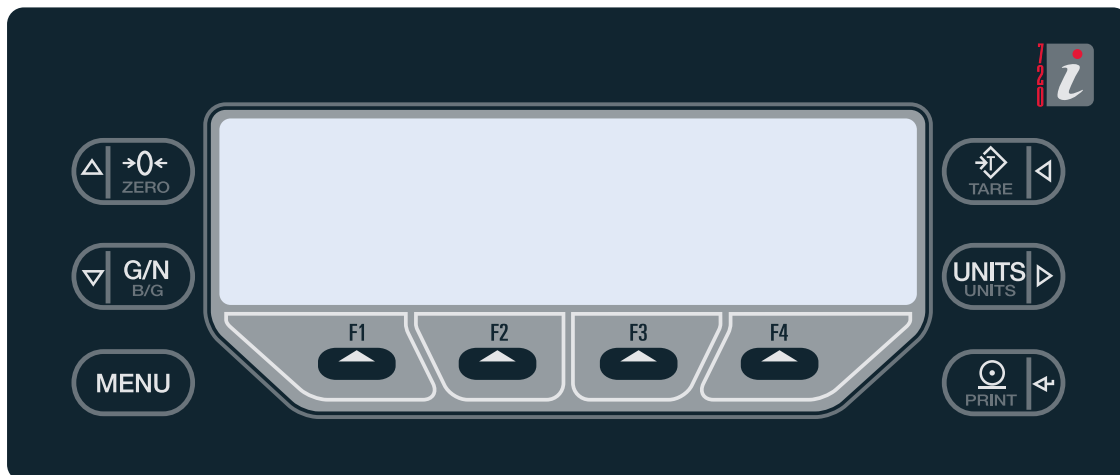

Figure 2-2. Panel Mount Front Panel









Item No.	Item	Description
	Tare	Performs a predetermined tare function; Used as the Left key to navigate menus or to edit a value
	Units	Switches the weight display to an alternate unit; Used as the Right key to navigate menus or to edit a value
	Print	Sends an on-demand print format out a communications port, provided the conditions for standstill are met
	Menu	Accesses/exits the menu structure; Functions as a Cancel key when editing a parameter value
	Gross/Net	Indicates whether the weight value is in Net or Gross mode; Used as the Down key to navigate menus or to edit a value
	Zero	Sets the current gross weight to zero; Used as the Up key to navigate menus or to edit a value
	F-Keys	Keys that can be configured to provide additional operator functions
	Clear	Backspace when entering numbers/letters
	Decimal	Inserts a decimal point as needed

Table 2-1. Front Panel

2.1 Operating Modes

The 720i has two modes of operation, Weigh Mode and Setup Mode. See the following information for an overview of Weigh Mode and Setup Mode.

2.1.1 Weigh Mode

The indicator displays gross, net, or tare weights as required to indicate scale status and the type of weight value displayed.

2.1.2 Setup Mode

Most of the procedures described in this manual require the indicator to be in Setup mode, including configuration and calibration.

To enter setup mode, press the **Menu** key on the front panel, select **Configuration** then press **Enter**. The indicator display changes to show the scale configuration menus.



NOTE: Jumper J9 must be installed to enable access to setup mode (Figure 3-2 on page 18). When configuration is complete, remove the jumper (place the jumper on a single pin of J9) to disable access to the configuration menus and affix a legal seal to the fillister-head screws on the indicator enclosure.

2.2 Indicator Operations

The following information summarizes basic 720i operations.

2.2.1 Display Menu

Press the **Menu** key to show the system menu then use the **Up** or **Down** navigation keys to select an item from the list. The menu provides access to audit trail information, configuration, test operations and display contrast adjustment.

2.2.2 Toggle Gross/Net Mode

Press the **Gross/Net** key to switch the display mode from gross to net, or from net to gross. If a tare value has been entered or acquired, the net value is the gross weight minus the tare. If no tare has been entered or acquired, the display remains in gross mode.

Gross mode is indicated by the letter **G** (gross) or, in OIML mode, **B** (brutto); net mode is indicated by the letter **N**.

2.2.3 Toggle Units

Press the **Units** key to switch between primary, secondary and tertiary units.

2.2.4 Zero Scale

1. In gross mode, remove all weight from the scale and wait for the standstill annunciator (▲ ▲).
2. Press the **Zero** key. The center of zero (→0←) annunciator lights to indicate the scale is zeroed.

2.2.5 Acquire Tare

1. Place the container on the scale and wait for the standstill annunciator (▲ ▲).
2. Press the **Tare** key to acquire the tare weight of the container.
3. The display shifts to net weight and shows the letter **N** on the display.

2.2.6 Enter Tare Value

For the universal model, use the numeric keypad to key in the tare value then press the **Tare** softkey or press and hold the front panel **Tare** key to enter the tare.

For the panel mount model, do the following:

1. Press and hold the **Gross/Net** key for about three seconds. When released, a zero appears.
2. Use the **Up** and **Down** navigation keys to adjust the value (0–9 and a decimal point) and the **Right** and **Left** navigation keys to select the digit.
3. Press the **Tare** softkey or press and hold the front panel **Tare** key for three seconds then release to enter the tare.

2.2.7 Remove Stored Tare Value

1. Remove all weight from the scale and wait for the standstill annunciator (▲ ▲).
2. Press the **Tare** key (or, in OIML mode, the **Zero** key). Display shifts to gross weight and shows the word **Gross**.

2.2.8 Print Ticket

1. Wait for the standstill annunciator (▲ ▲).
2. Press the **Print** key to send data to the serial port.

2.2.9 Select Auxiliary Print Format

Any of the auxiliary print formats (1–20) can be selected for printed output while in weighing mode.



NOTE: Not available in Advance Truck Mode.

For the universal model, use the numeric keypad to key in the print format value then press the **Print** softkey or the front panel **Print** key to print using the selected auxiliary format.

For the panel mount model, do the following:

1. Press and hold the **Gross/Net** key for about three seconds. When released, a zero appears.
2. Use the **Up** and **Down** navigation keys to adjust the value (0–9 and a decimal point) and the **Right** and **Left** navigation keys to select the digit.
3. Press the **Print** softkey or the front panel **Print** key to print using the selected auxiliary format.

2.2.10 Accumulator Functions

The accumulator must be enabled before use. Once enabled, weight (net weight if a tare is in the system) is accumulated whenever a print operation is performed using the **Print** key, digital input or serial command. The scale must return to zero (net zero if a tare is in the system) before the next accumulation.

The **Display Accum** softkey can be configured to display the current accumulator value. Printing while the accumulator is displayed uses the ACCFMT print format ([Section 7.0 on page 65](#)).

Press the **Clear** key twice to clear the accumulator.



NOTE: With the panel mount version of the 720i, use CLR Accumulator DigIn Function to clear the accumulator.

2.3 Softkey Operations

Softkeys provide additional operator functions for specific applications. Softkey assignments are listed on the tabs shown at the bottom of the LCD display. Softkey functions are activated by pressing the arrow keys below the softkey tabs (Figure 2-1 on page 10 and Figure 2-2 on page 10).

For example, to set up a **Time/Date** softkey using serial commands, do the following:

1. Place the indicator in setup mode.
2. Send the following serial command:
SK#s=TimeDate
where **s** is the softkey position.
3. Press **SaveExit** (or send the KSAVEEXIT serial command). The new softkey displays in the position specified by **s**.
4. Press the **Time/Date** softkey. Use the **Up/Down** navigation keys to adjust the time and date value. Use the **Left/Right** keys to move between fields. Time and date fields are presented in the following order:
HOURL>MIN>[AM/PM]>MONTH>DAY>YEAR
5. When done, press **Enter** to return to weighing mode.

The particular set of softkeys shown on the display can be set using serial commands or Revolution.

Softkey	Description
None	Not configured; No softkeys displays after a None key
<blank>	Empty key; Allows for a space/blank between other softkeys
Time/Date	Displays current time and date; Allows time and date change
Display Tare	Displays tare value for the current scale
Display Accum	Displays accumulator value, if enabled, for the current scale
Display ROC	Displays rate-of-change value, if enabled, for the current scale
*Weigh In	Allows truck ID entry; Generates weigh-in ticket for truck weighing applications
*Weigh Out	Allows truck ID entry; Generates weigh-out ticket for truck weighing applications
*Truck Regs	Displays truck register; Allows deletion of individual or all entries; Truck register can be printed by pressing the Print key while the truck register is displayed
Alibi	Allows previous print transactions to be recalled and reprinted
SKUD 1-10	User-programmable keys; Defined by PCEE
**Setpoint	Displays a menu of configured setpoints; Allows display and change of some setpoint parameters
**Batch Start	Starts a configured batch
**Batch Stop	Stops a running batch and turns off all associated digital outputs; Requires a batch start to resume processing
**Batch Pause	Pauses a running batch (same as stop, but digital outputs, if on, are not turned off)
**Batch Reset	Stops a batch and resets it to the first batch step
***Weigh	Start the Weigh-In and Weigh-Out Procedure
***Reports	Select which report to print; There are four sub menus under the Reports softkey; Summary , Daily , Detail , and Code List
***Management	Add and remove materials, customers, source IDs and names
More...	For applications with more than three defined softkeys, the More... key is automatically assigned to the fourth softkey position; Press More... to toggle between groups of softkeys
*Truck Modes 1-6 only	
**720i Batching Version software only	
***Advance Truck Mode only	

Table 2-2. Configurable Softkeys

3.0 Installation

This section describes procedures for connecting load cell, digital I/O and serial communications cables to the 720i indicator assembly drawings and replacement parts lists for the universal model are included for the service technician.

See [Section 12.12 on page 127](#) for dimension drawings.



WARNING



*Risk of electrical shock.
Risque de choc.*



*Disconnect power before servicing.
Débranchez l'alimentation avant l'entretien.*



AVERTISSEMENT



CAUTION: *Risk of explosion if battery is replaced by an incorrect type. Dispose of used batteries according to state and local regulations.*



ATTENTION: *Risque d'explosion si la batterie est remplacée par un type incorrect. Mettre au rebut les batteries usagées selon les règlements d'état et locaux.*



WARNING: *Failure to heed the following statements could result in serious injury or death.*

- *Procedures requiring work inside the product enclosure must be performed by qualified service personnel only.*
- *Use a grounding wrist strap to protect components from electrostatic discharge (ESD) damage when working inside the product enclosure.*
- *The power cord serves as the power disconnect for the 720i. Ensure the power cord is unplugged prior to opening the enclosure. The power outlet must be near the equipment and must be easily accessible.*

3.1 Unpacking and Assembly

Immediately after unpacking, visually inspect the 720i to ensure all components are included and undamaged. The shipping carton should contain the indicator and a parts kit. If parts were damaged in shipment, notify Rice Lake Weighing Systems and the shipper immediately.



IMPORTANT: *Retain the packaging for use in future shipment or transportation. The product must be properly packed with the original carton and packaging materials when shipping the high-precision scale system back.*

See [Section 3.12 on page 25](#) for parts kit contents.

3.2 Enclosure Disassembly

The indicator enclosure must be opened to install option cards and to connect cables for installed option cards.



WARNING: *The 720i does not have an on/off switch. Before opening the unit, ensure the power cord is disconnected from the power outlet.*

1. Ensure power to the indicator is disconnected.
2. Place the indicator face-down on an anti-static work mat.
3. Remove the screws that hold the backplate to the enclosure body.
4. Lift the backplate away from the enclosure and set it aside.

3.3 Cable Connections

The universal model of the 720i provides six cord grips for cabling into the indicator: one for the power cord and five to accommodate other cabling. Install plugs in all unused cord grips to prevent moisture from entering the enclosure.

Cable Diameter Ranges

Refer to [Table 3-1](#) for minimum and maximum cable sizes for use with the cord grips.

Cord Grip	Diameter Range
PG-9 (PN 15626)	0.138 - 0.315 in (3.5 - 8 mm)
PG-11 (PN 68600)	0.197 - 0.394 in (5 - 10 mm)
1/2 NPT (PN 15628)	0.197 - 0.472 in (5 - 12 mm)

Table 3-1. Cord Grip Cable Diameter Ranges

Torque Ratings

Refer to [Table 3-2](#) throughout installation and use of the product to maintain proper torque ratings for 720i components.

Component	Torque Rating
Backplate Screw	15 in-lb (1.7 N-m)
Cord Grip Nut (to enclosure)	33 in-lb (3.7 N-m)
Cord Grip Dome Nut (around cable)	22 in-lb (2.5 N-m)

Table 3-2. Component Torque Ratings

3.3.1 Load Cells

Use the following instructions to attach a cable from a load cell or junction box to the 720i.

1. Route the cable through the cord grip and ground the shield wire as described in [Section 3.6 on page 19](#).
2. Remove load cell connector J1 from the CPU board.
3. Wire the load cell cable from the load cell or junction box to the connector as shown in [Table 3-3](#).

J1 Connector Pin	Function
1	+SIG
2	-SIG
3	+SENSE
4	-SENSE
5	+EXC
6	-EXC

Table 3-3. Load Cell Connector Pin Assignments



NOTE: For 6-wire load cell connections, remove jumpers JP1 and JP2.

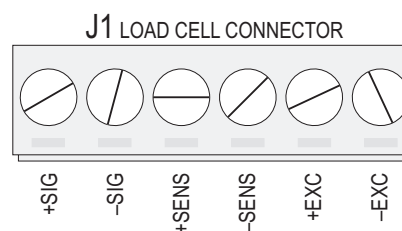

Figure 3-1. Load Cell Connector

4. If using a 6-wire load cell cable (with sense wires), remove jumpers JP1 and JP2 before reinstalling connector J1. For 4-wire installation, leave jumpers JP1 and JP2 on.
5. When connections are complete, reinstall the load cell connector on the CPU board header and use two cable ties to secure the load cell cable to the inside of the enclosure.

3.3.2 Serial Communications

Communications ports on the 720i CPU board support full duplex RS-232 and 20 mA output communications at up to 115200 bps. Optional communications cards support USB, and Ethernet connections to the 720i.

1. To attach serial communications cables, route the cable through the cord grip and ground the shield wire as described in [Section 3.6 on page 19](#).
2. Remove the serial connector from the CPU board and wire to the connector.
3. Once cables are attached, plug the connector into the header on the board.
4. Use cable ties to secure serial cables to the inside of the enclosure.

Port 3 uses connector J4 to provide a dedicated display port for both universal and panel mount versions.

Connector	Pin	Signal	Port
J3	1	CLK	1
	2	+5 V	
	3	GND	
	4	DATA	
J2	1	GND	2
	2	RS-232 RxD	
	3	RS-232 TxD	
	4	RS-232 RTS	
	5	RS-232 CTS	
	6	GND	
J4	1	RS-422/485 Y	3
	2	RS-422/485 Z	
	3	RS-422/485 B	
	4	RS-422/485 A	
	5	+6 V	
	6	GND	
J5	1	GND	4
	2	RS-232 RxD	
	3	RS-232 TxD	
	4	20 mA OUT	

Table 3-4. Serial Port Pin Assignments

Serial ports are configured using the Serial menu. See [Section 4.2.3 on page 46](#) for configuration information.

An optional dual-channel serial communications expansion card, PN 67604, is also available. The serial expansion card provides two additional serial ports, assigned as port numbers 7 and 8. One port on the serial expansion card supports 4-wire RS-485 communications. Both ports on the expansion card can support RS-232 or 20 mA connections.



NOTE: Installation of option cards in connector J11 requires removal of the PORT2/OPTI port selection jumper ([Figure 3-2 on page 18](#)). Install the jumper to enable RS-232 communications through connector J2; remove the jumper to enable a USB or Ethernet option card installed in connector J11.

3.3.3 Digital I/O

Digital inputs can be set to provide many indicator functions, including all keypad functions.

Digital inputs are active low (0 VDC), inactive high (5 VDC).

Digital outputs are typically used to control relays that drive other equipment. Outputs are designed to sink, rather than source, switching current. Each output is a normally open collector circuit, capable of sinking 24 mA when active.

Digital outputs are wired to switch relays when the digital output is active (low, 0 VDC) with reference to a 5 VDC supply.

Table 3-5 shows the pin assignments for connector J6.

J6 Pin	J6 Signal
1	+5 VDC
2	GND
3	DIO 1
4	DIO 2
5	DIO 3
6	DIO 4
7	DIO 5
8	DIO 6
9	DIO 7
10	DIO 8

Table 3-5. J6 Pin Assignments (Digital I/O)

Digital inputs and outputs are configured using the DIG I/O menu. See Section 4.2.6 on page 56 for configuration information.

An optional 24-channel digital I/O expansion card, PN 67601, is available for applications requiring more digital I/O channels.



NOTE: A digital I/O point can be configured to count active pulse inputs by setting the bit to Input (digital I/O menu) and using PCEE to monitor the bit.

NOTE: The fastest pulse rate which can be counted using a digital input is 10 Hz (10 pulses per second).

3.3.4 Detached Display Module (DDM)

Table 3-6 shows the connections between connector J4 on the 720i CPU board and connector J3 (Com 1) on the detached display module (DDM) board. See board diagrams in Figure 3-2 on page 18 and Figure 3-3 on page 19.



NOTE: Connections are made horizontally within Table 3-6. For example, Connect Pin 1 on the DDM to Pin 1 on the CPU board (connect Signal A on the DDM to Signal Y on the CPU board).

DDM Com 1 J3 Connector		CPU Board J4 Connector	
Pin	Signal	Pin	Signal
1	A	1	Y
2	B	2	Z
3	Z	3	B
4	Y	4	A
5	+6 V	5	+6 V
6	GND	6	GND

Table 3-6. CPU Board—DDM Connections

3.4 Installing Option Cards

Each option card is shipped with specific installation instructions. Use the following general procedure for all option cards.



CAUTION: Disconnect power to the 720i before installing option cards. Option cards are not hot-swappable.

1. Disconnect power to the indicator. Remove backplate as described in [Section 3.2 on page 14](#).
2. Carefully align the option card connector with connector J12 or J11 on the CPU board ([Figure 3-2](#)).
3. Press down to seat the option card in the CPU board connector.
4. Use the screws provided in the option kit to secure the other end of the option card to the threaded standoffs on the CPU board ([Figure 3-2](#)).
5. Make connections to the option card as required.
6. Use cable ties to secure loose cables inside the enclosure.
7. When installation is complete, reassemble the enclosure as described in [Section 3.7 on page 20](#).

The 720i automatically recognizes all installed option cards when the unit is powered on. No hardware-specific configuration is required to identify the newly installed card to the system.

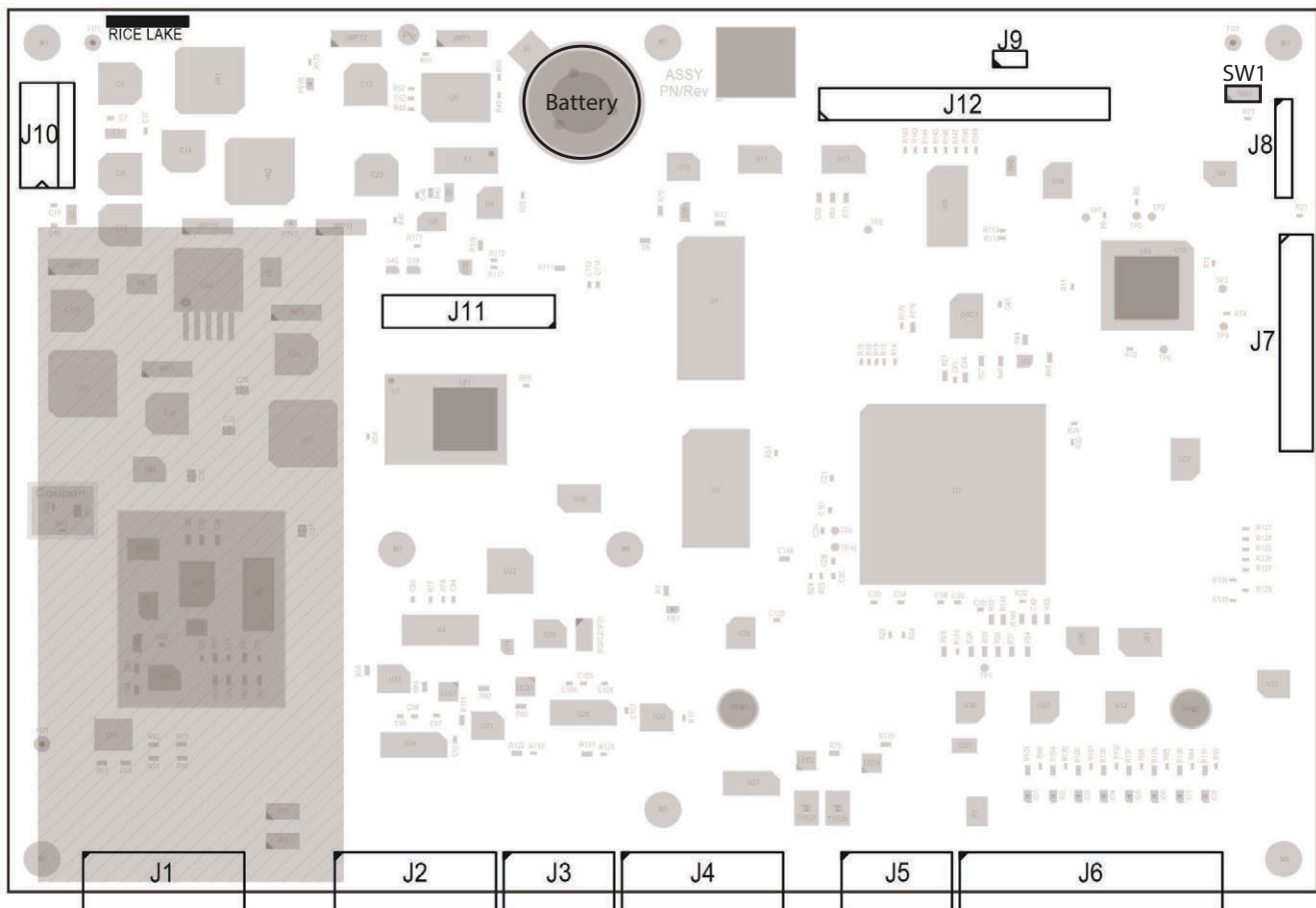

Figure 3-2. 720i CPU Board

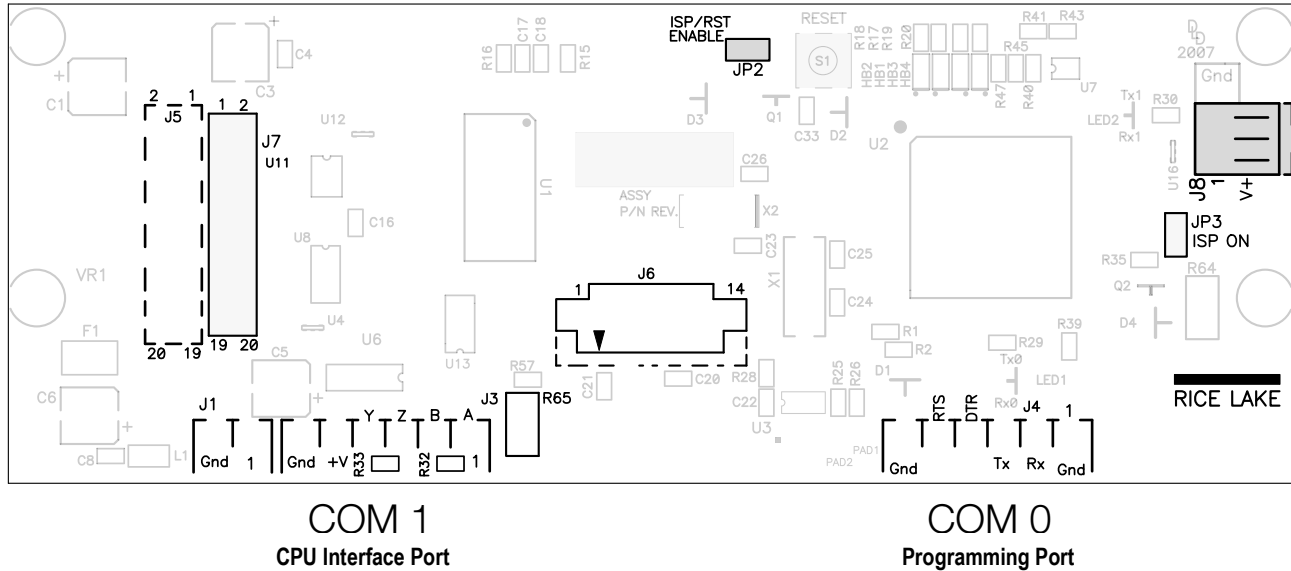

Figure 3-3. 720i Display Board

3.5 Slot Assignments

Table 3-7 lists the slot numbers, CPU board connectors and configuration assignments made for both onboard and expansion card functions in the 720i. See Figure 3-2 on page 18 for connector locations.

Slot Number	Connector	Function	Configured As
0	Connector J6	Onboard Digital I/O	Slot 0, bits 1–8
	Connectors J3, J2, J5	Onboard Serial Communications	Ports 1, 2, 4
1	Connector J1	Onboard Single-channel A/D	Channel 1
2	Connectors J12 (expansion card slot) and J11 (communications option card slot)	Dual-channel Serial Expansion Card	Ports 7–8
		Digital I/O Expansion Card	Slot 2, bits 1–24
		Analog Output Card	Analog 2
		Bus Communications Card	Bus Option 2

Table 3-7. 720i Slot Assignments

3.6 Grounding Cables/Wires

Except for the power cord, all cables routed through the cord grips should be grounded against the indicator enclosure.

1. Install the grounding clamps on an enclosure stud near the cord grip being used.
2. Secure the ground clamp with hardware included in the hardware kit. Do not tighten the screws at this time.
3. Route the cables through the cord grips and the grounding clamps to determine the cable lengths required to reach the cable connectors.
4. Mark the cables to remove insulation and shield (Section 3.6.1 on page 20).
5. Route stripped cables through the cord grips and grounding clamps.
6. Ensure the shields contact the grounding clamps and tighten the ground clamp screws.

3.6.1 Stripping Cables

Foil Insulated Cable

1. Strip the insulation and foil from the cable 1/2 inch (15 mm) past the grounding clamp.

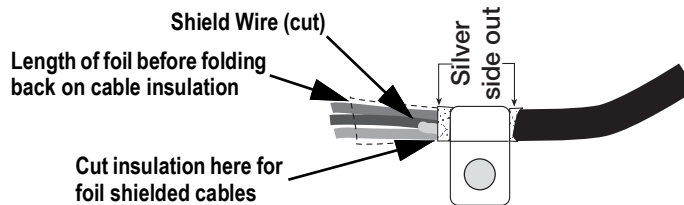

Figure 3-4. Foil Insulated Cable

2. Fold the foil shield back on the cable where the cable passes through the clamp.
3. Ensure the silver (conductive) side of the foil is turned outward for contact with the grounding clamp.

Braided Shielding

1. Strip the insulation and braided shield from a point just past the grounding clamp.

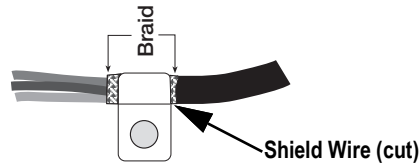

Figure 3-5. Braided Insulated Cable

2. Strip another 1/2 inch (15 mm) of the insulation to expose the braid where the cable passes through the clamp.

Load Cell Cable

Cut the shield wire just past the grounding clamp. Shield wire function is provided by contact between the cable shield and the grounding clamp.

3.7 Enclosure Reassembly

Once cabling is complete, position the backplate over the enclosure and reinstall the backplate screws.

Use the torque pattern shown in Figure 3-6 to prevent distorting the backplate gasket. Torque screws to 15 in-lb (1.7 N-m).

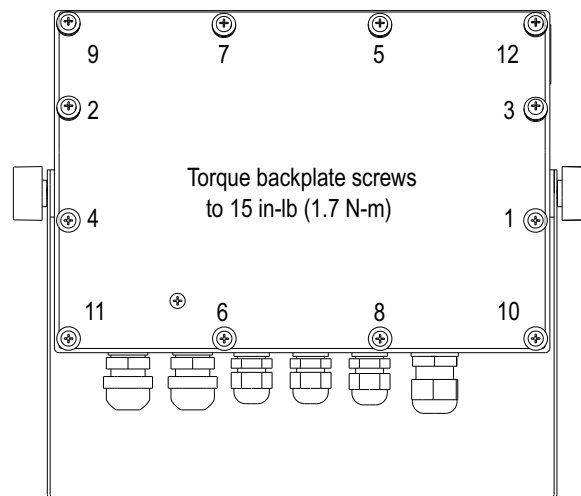

Figure 3-6. 720i Enclosure Backplate



IMPORTANT: Torqued screws may become less tight as the gasket is compressed during torque pattern, therefore a second torque is required using the same pattern and torque value.

3.8 Panel Mount Installation

This section includes instructions for installation of the 720i panel mount indicator.

3.8.1 Panel Mount Cutout Dimensions

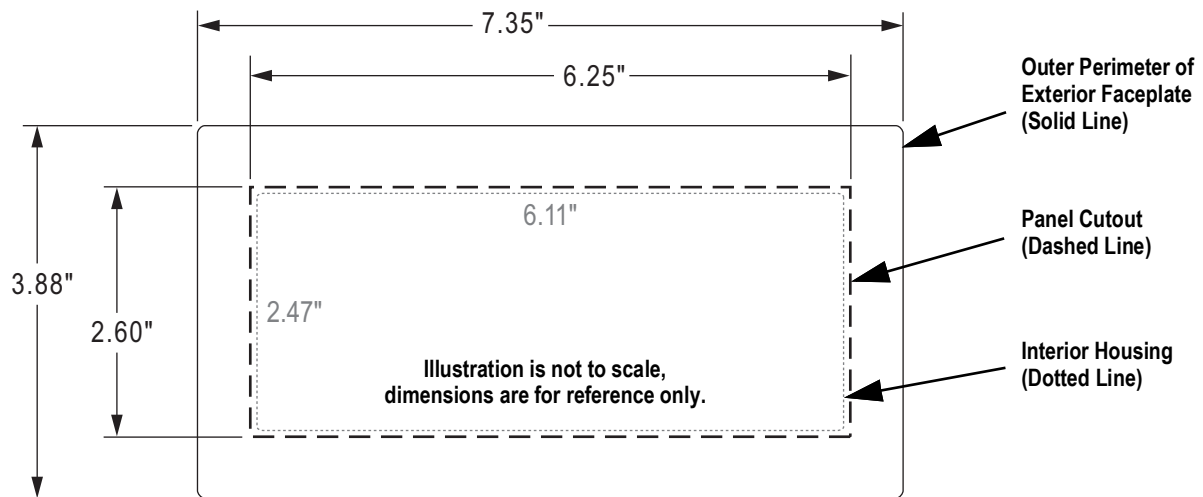

Figure 3-7. Panel Cutout for Panel Mount Enclosure

3.8.2 Panel Mount Display Installation

Install the panel mount display once the cutout has been prepared in the panel.

1. Insert the display enclosure into the cutout from the front of the panel.
2. Place the backing plate on the enclosure from the inside of the panel.
3. Place the clinching bracket on the enclosure, outside of the backing plate, from inside the panel.

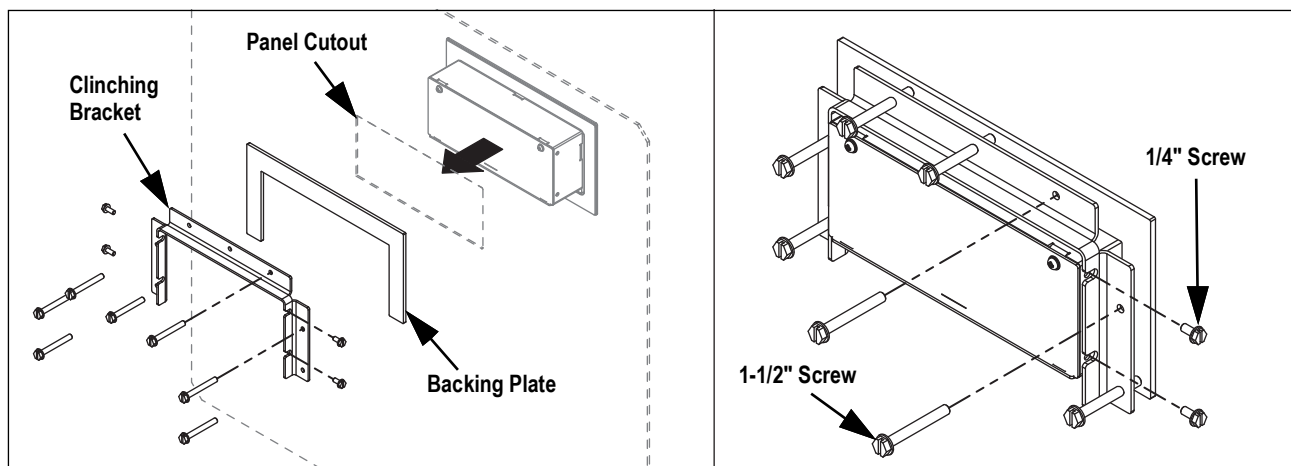

Figure 3-8. Panel Mount Display Installation

4. Secure the clinching bracket to the enclosure using the four 1/4" screws (PN 71522) provided in the parts kit.
5. Use the seven 1-1/2" screws (PN 82425) to secure the panel mount display to the panel.

3.8.3 Panel Mount Controller Installation

Install the Panel mount controller near the display. The cable that connects the controller and display is six feet long.

1. Position the panel mount controller and mark mounting screw locations.
2. Secure the controller to panel with appropriate hardware (not included).

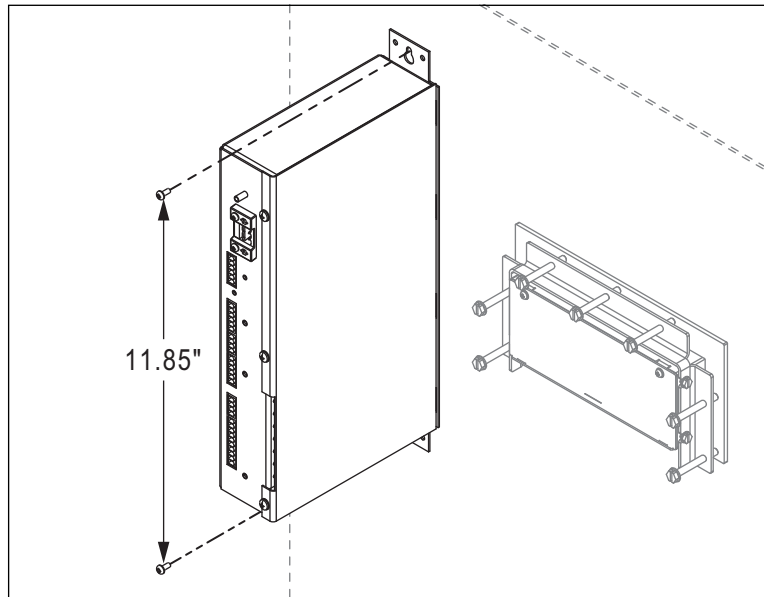

Figure 3-9. Panel Mount Controller Installation

3.8.4 Panel Mount Cable Connections

Connect cables to the panel mount display and controller once both are properly mounted to the panel. See [Section 3.3 on page 15](#) for details on the available 720i CPU board ports.

1. Use the panel mount cable (PN 105348) with 6-pin connectors on both ends to connect the display to the controller.
2. Earth ground the panel mount controller using the grounding stud next to the power connector.
3. Connect power cable to the panel mount controller.

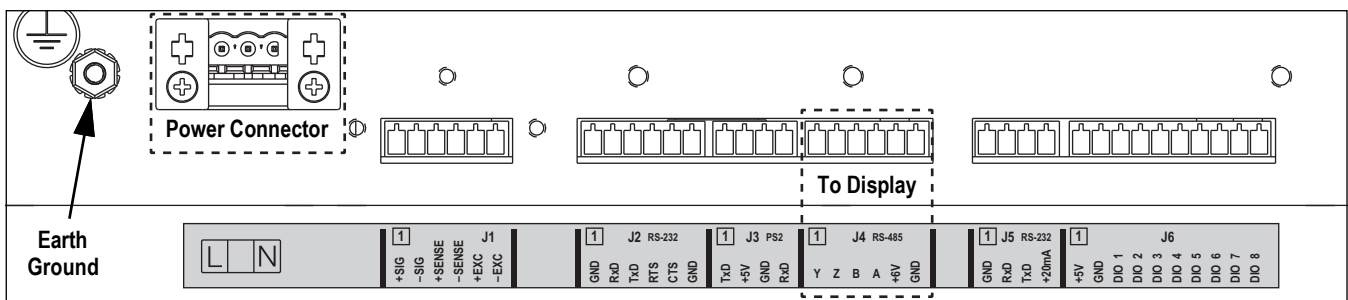

Figure 3-10. Panel Mount Controller Connectors

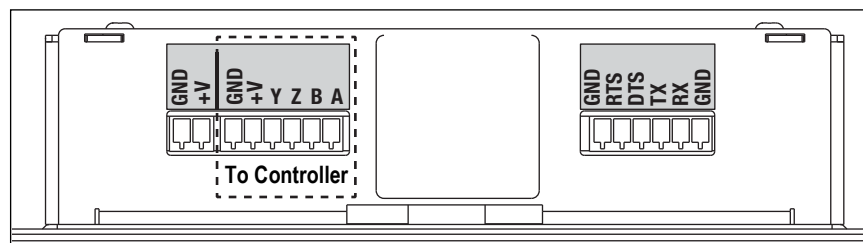

Figure 3-11. Panel Mount Display Connectors

3.9 Legal for Trade Sealing

In certain Legal for Trade applications, it may be necessary to seal the indicator to restrict access to the setup switch.

3.9.1 Security Sealing

A wire security seal can be threaded through three fillister head screws that secure the back cover of the indicator to prevent undetected access to a calibration jumper that must be moved to enter the set-up and calibration mode, on the inside of the bottom of the indicator.

The device also has a category 2 audit trail that is accessed through the keyboard.

There are two event counters

- Calibration
- Configuration

Universal Mount

For proper sealing of the 720i Universal Mount, see [Figure 3-12](#).

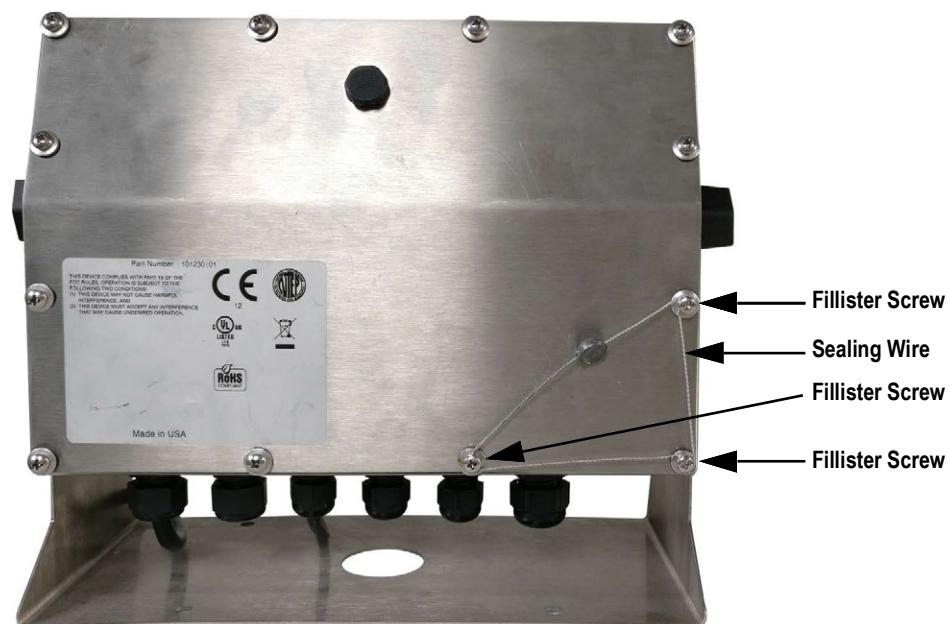

Figure 3-12. Sealed Universal Mount

Panel Mount

For proper sealing of the 720i Panel Mount, see [Figure 3-13](#).

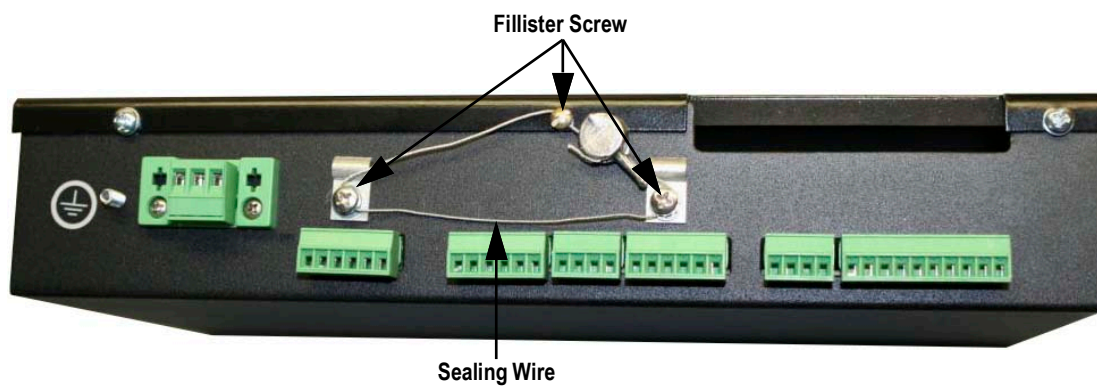

Figure 3-13. Sealed Panel Mount

3.10 CPU Board Removal

If the 720i CPU board must be removed, use the following procedure:

1. Disconnect power to the indicator.
2. Remove the backplate as described in [Section 3.2 on page 14](#).
3. Unplug connectors for power to the board, serial communications, digital I/O and installed option cards.
4. Remove installed option cards.
5. Remove the five Phillips head screws and the kep nut from the CPU board.
6. Remove CPU board from the enclosure. If necessary, cut cable ties to shift cables out of the way.

To replace the CPU board, reverse the above procedure. Be sure to reinstall cable ties to secure all cables inside the indicator enclosure.

3.11 Battery Replacement

The lithium battery on the CPU board maintains the real-time clock and protects data stored in the system RAM when the indicator is not connected to AC power.

Data protected by the CPU board battery includes time and date, truck and tare memory, and onboard database information.

Use Revolution to store a copy of the indicator configuration on a PC before attempting battery replacement.

If data is lost, the indicator configuration can be restored from the PC.

Watch for the low battery warning on the LCD display and periodically check the battery voltage on both the CPU board and on installed memory option cards. Batteries should be replaced when the indicator low battery warning comes on, or when battery voltage falls to 2.2 VDC. Life expectancy of the battery is ten years.

3.11.1 Replacement Procedure

For best results, replace the battery while in weigh mode and with AC power applied. Use care not to bend the battery retaining spring.

If the battery must be replaced with power removed, do the following immediately after restoring power:

1. Enter setup mode.
2. Navigate to the **Version** menu and press the **RSConfig** softkey. If connected using Revolution, configuration can be reset by using monitor mode to enter the RESETCONFIGURATION command followed by the RS command.

See [Figure 3-2 on page 18](#) for CPU board battery location and orientation (positive side up).



WARNING: *There is a risk of explosion if battery is replaced with the incorrect type. Dispose of batteries per manufacturer instruction.*

3.12 Replacement Parts and Assembly Drawings

See the following information for replacement parts and assembly drawings.

3.12.1 Universal Model

Table 3-8 on page 27 lists replacement parts and parts kit contents for the 720i universal enclosure model, including all parts referenced in Figure 3-14 through Figure 3-16 on page 26.

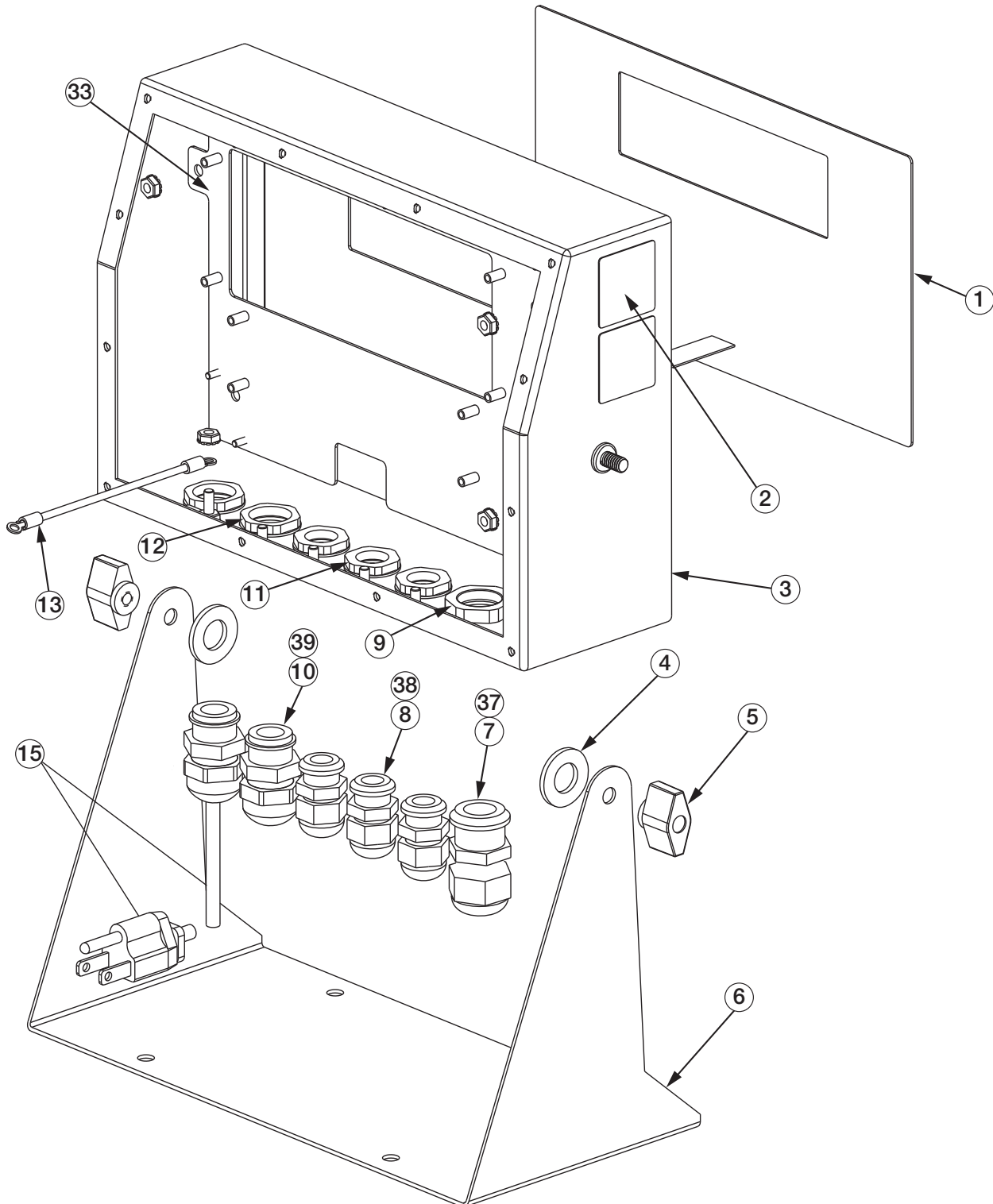

Figure 3-14. 720i Universal Model Assembly, Enclosure and Tilt Stand

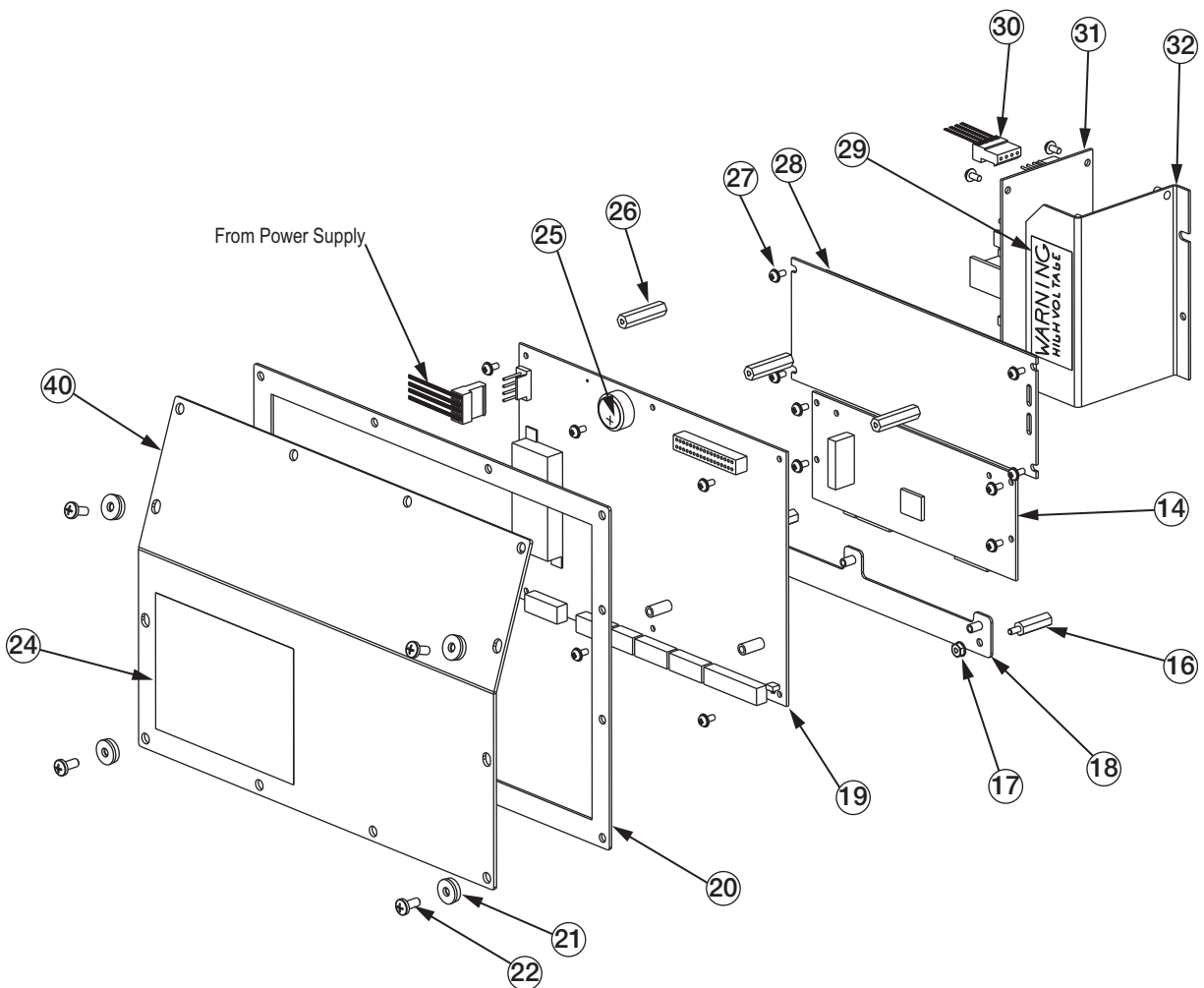

Figure 3-15. 720i Universal Model, CPU Board and Backplate

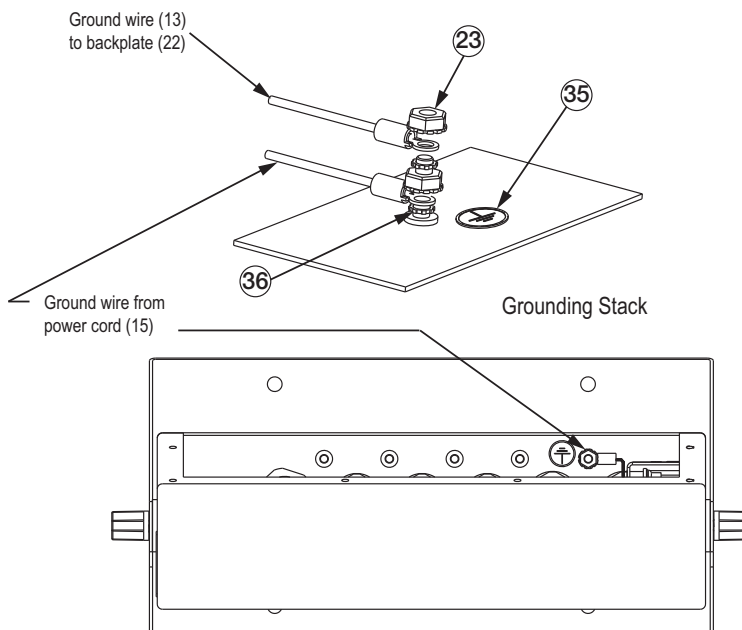

Figure 3-16. 720i Universal Model, Grounding Detail

Item No.	Part No.	Description	Qty.	See Figure
1	101257	Switch Panel Membrane, Universal	1	Figure 3-14 on page 25
2	53308	Model/serial Number Label	1	
3	101263	Enclosure, Universal	1	
4	103988	Tilt Stand Washers, in Parts Kit	2	
5	103610	Tilt Stand Knobs, in Parts Kit	2	
6	67531	Tilt Stand	1	
7	15628	Cord Grip, 1/2 NPT	1	
8	15626	Cord Grip, PG9	3	
9	15630	Lock Nut for 1/2 NPT Cord Grip	1	
10	68600	Cord Grip, PG11	1	
11	15627	Lock Nut, PCN9	3	
12	68601	Lock Nut, PG11	1	
13	45043	Ground Wire, 4" with No. 8 Eye Connector	1	
14	102887	Display Board Assembly, Universal	1	
15	85202	Power Cord Assembly, 115 VAC and 230 VAC North American Units	1	Figure 3-14 on page 25
	85203	Power Cord Assembly, 230 VAC European Units		—
16	67885	Standoffs, M-F, 4-40NC x 3/4	2	Figure 3-15 on page 26
17	14618	Kep Nut, 4-40NC Hex	3	
18	103443	CPU Board Mounting Strip	1	
19	106788	720i CPU Board (PCE Version)	1	
	195388	720i CPU Board (Batching Version)		
20	102376	Backplate Gasket, Universal	1	Figure 3-15 on page 26
21	75062	Sealing Washer*	4	
22	14862	Machine Screw, 8-32NC x 3/8*	4	
23	14626	Kep Nut, 8-32NC*	7	Figure 3-16 on page 26
24	53307	Label	1	Figure 3-15 on page 26
25	69291	3 V Lithium Coin Battery	—	
26	103989	Standoff, F-F, 4-40 x 1.06	3	
27	14825	Machine Screw, 4-40NC x 1/4	18	
28	102888	LCD Display Module, 240x64, Universal	1	
29	16861	High Voltage Warning Label	1	
30	67796	Power Supply Cable Assembly, to CPU Board	1	
31	67613	Power Supply, ±6 VDC, 25 W	1	
32	103442	Power Supply Bracket	1	
33	103936	Component Plate	1	
35	16892	Ground/Earth Label	1	Figure 3-16 on page 26
36	15134	Lock Washer, No. 8, Type A	3	Figure 3-14 on page 25
37	30376	Nylon Seal Ring for 1/2 NPT Cord Grip	1	
38	30375	Nylon Seal Ring for PG9 Cord Grip	3	
39	68599	Nylon Seal Ring for PG11 Cord Grip	1	Figure 3-15 on page 26
40	102377	Enclosure Backplate, Universal	1	
—	103458	Ribbon Cable Assembly, 7", 20-pin Female, Universal	1	
—	103609	Cable Assembly, CPU-to-Display, Universal	1	

* Additional parts included in parts kit

Table 3-8. Universal Model Replacement Parts

Item No.	Part No.	Description	Qty.	See Figure
Universal Model Parts Kit Contents				
	104033	720i Software Tool Kit CD	1	–
	103988	Tilt Stand Washer	2	–
	103610	Tilt Stand Knob	2	–
	42149	Rubber Feet, Tilt Stand	4	–
	30623	Machine Screw, 8-32NC x 7/16	3	–
	14626	Kep Nut, 8-32NC	4	–
	14862	Machine Screw, 8-32NC x 3/8	5	–
	15134	Lock Washer, No. 8, Type A	4	–
	15631	Cable Tie	5	–
	15665	Reducing Gland for 1/2 NPT Cord Grip	1	–
	19538	Cord Grip Plug	4	–
	53075	Cable Shield Ground Clamp	4	–
	75062	Sealing Washer	8	–
	71344	10-Position Screw Terminal for J6	1	–
	76513	4-Position Screw Terminal for J3 and J5	2	–
	76514	6-Position Screw Terminal for J1, J2 and J4	3	–
	94422	Capacity Label	1	–

Table 3-8. Universal Model Replacement Parts (Continued)

3.12.2 Panel Mount Display

Table 3-9 lists replacement parts and parts kit contents for the 720i panel mount remote display unit, including all parts referenced in Figure 3-17.

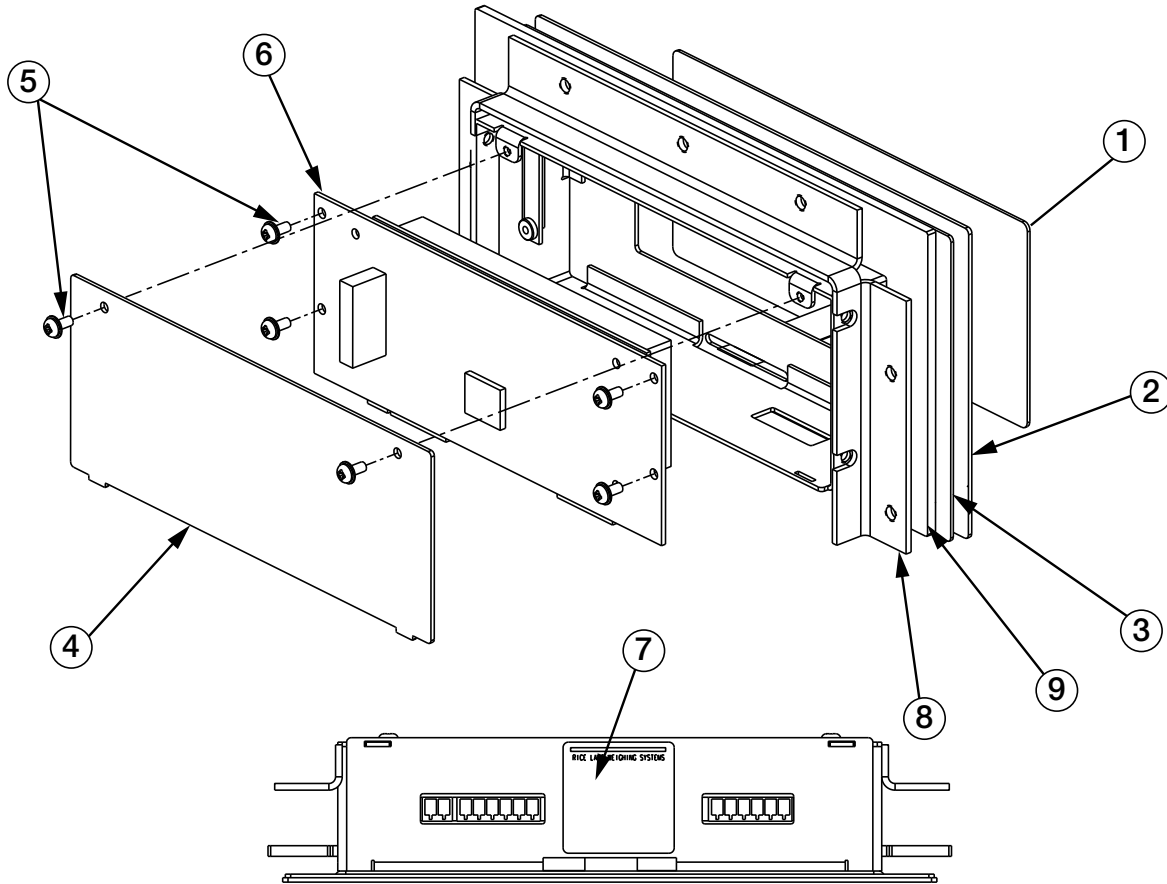

Figure 3-17. 720i Panel Mount Display Assembly

Item No.	Part No.	Description	Qty.
1	101256	Switch Panel Membrane, Panel Mount Display	1
2	101265	Faceplate, Panel Mount Display	1
3	68719	Faceplate Gasket, Panel Mount Display	1
4	102605	Backplate, Panel Mount Display	1
5	14822	Machine Screw, 4-40NC x 1/4	6
6	101239	Remote Display Board Assembly	1
7	53308	Label	1
8	69787	Clinching Bracket	1
9	82426	Backing Plate, Panel Mount Display	1
Panel Mount Remote Display Parts Kit Contents			
	76514	6-Position Screw Terminal	1
	94422	Capacity Label	1
	53075	Cable Shield Ground Clamp	1
	71522	Machine Screw, 8-32NC x 1/4	4
	82425	Machine Screw, 10-32NF x 1.50	7

Table 3-9. Panel Mount Display Unit Replacement Parts

3.12.3 Panel Mount Controller

Table 3-10 on page 31 lists replacement parts and parts kit contents for the 720i panel mount controller, including all parts referenced in Figure 3-18.

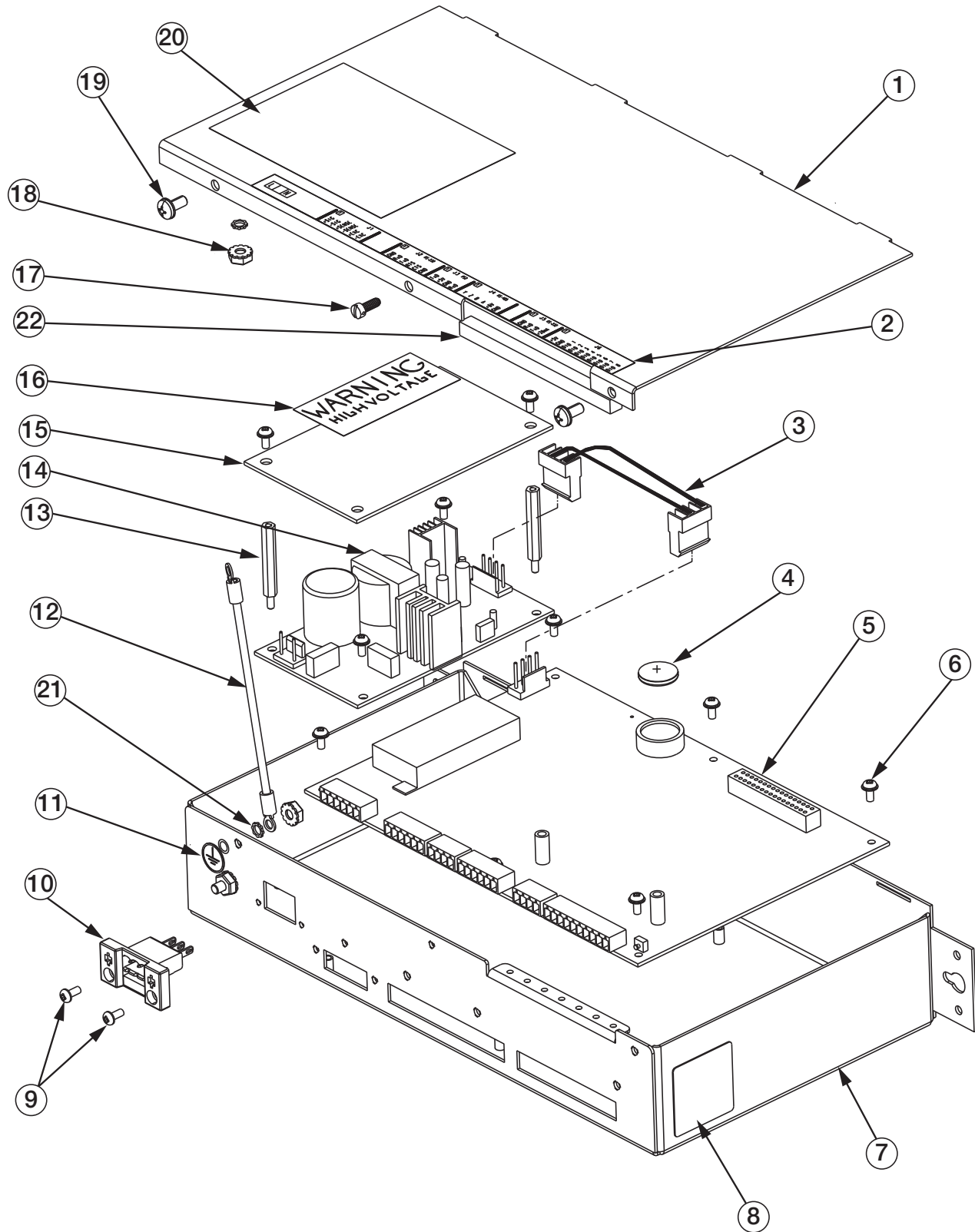

Figure 3-18. Panel Mount Controller Assembly

Item No.	Part No.	Description	Qty.
1	103314	Panel Mount Controller Cover	1
2	103677	Panel Mount Controller Connector Label	1
3	101263	Enclosure, Universal	1
3	67796	Power Supply Cable Assembly, to CPU Board	1
4	69291	3 V Lithium Coin Battery	
5	106788	720i CPU Board (PCE Version)	1
	195388	720i CPU Board (Batching Version)	
6	14822	Machine Screw, 4-40NC x 1/4	10
7	101264	Panel Mount Controller Enclosure	1
8	53308	Label	2
9	14825	Machine Screw, 4-40NC x 1/4	2
10	103681	AC Feed-through Header	1
11	16892	Ground/Earth Label	1
12	15601	Ground Wire, 6" with No. 8 Eye Connector	1
13	67885	Standoffs, M-F 4-40NC x 1.25	2
14	67613	Power Supply, ± 6 VDC, 25 W	1
15	85494	Power Supply Cover	1
16	16861	High Voltage Warning Label	1
17	54206	Machine Screw, Fillister Head, 6-32NC x 3/8	1
18	14626	Kep Nut, 8-32NC Hex	2
19	14839	Machine Screw, 6-32NC x 1/4	2
20	53307	Label	1
21	15134	Lock Washer, No. 8, Type A	2
22	71698	Polyurethane Foam Strip	1
Panel Mount Controller Parts Kit Contents			
	15888	3-Position Terminal Block	1
	71344	10-Position Screw Terminal for J6	1
	76513	4-Position Screw Terminal for J3 and J5	2
	76514	6-Position Screw Terminal for J1, J2 and J4	3
	14626	Kep Nut, 8-32NC Hex	1
	14862	Machine Screw, 8-32NC x 3/8	2
	15134	Lock Washers, No. 8 Type A	7
	15694	No. 8 Crimp Connector	1
	53075	Cable Shield Ground Clamps	4
	30623	Machine Screw, Fillister Head, 8-32NC x 7/16	2
	94422	Capacity Label	1

Table 3-10. Panel Mount Controller Replacement Parts

4.0 Configuration

This section provides an overview of 720i Programmable HMI Indicator/Controller configuration instructions.

To configure the 720i indicator, press the **Menu** key on the front panel (only if jumper J9 is installed), press the **Down** key to select **Configuration** then press **Enter**. Detailed descriptions of the configuration menus are provided in [Section 4.2 on page 34](#).

When configuration is complete, press the **Save & Exit** softkey to exit setup mode. **Save & Exit** writes all parameter changes to NV RAM before returning to normal mode.



Figure 4-1. 720i Menu Display

4.1 Configuration Methods

The 720i indicator can be configured by using the front panel keys to navigate through a series of configuration menus or by sending commands or configuration data to an indicator serial port. Configuration using the menus is described in [Section 4.1.3 on page 33](#).

Configuration using the serial port can be accomplished using either the serial command set described in [Section 11.1 on page 100](#) or the Revolution configuration utility. There are two software modules available:

- 720i PCE
- 720i Batching



NOTE: Some configuration parameters cannot be accessed through the configuration menus. Revolution provides the most complete and efficient configuration interface for the 720i.

4.1.1 Revolution Configuration

The Revolution configuration utility provides the preferred method for configuring the 720i indicator. Revolution runs on a personal computer to set configuration parameters for the indicator. When Revolution configuration is complete, configuration data is downloaded to the indicator.

Revolution supports both uploading and downloading of indicator configuration data. This capability allows configuration data to be retrieved from one indicator, edited then downloaded to another indicator with an identical hardware configuration.

To use Revolution, do the following:

1. Install Revolution on a PC. See [Section 6.0 on page 63](#) for detailed hardware and software requirements.

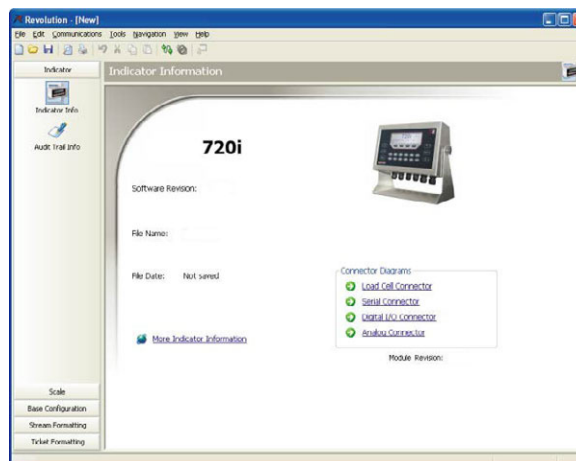

Figure 4-2. Revolution Display for 720i PCE Version

2. With both indicator and PC powered off, connect the PC serial port to the RS-232 pins on the indicator serial port or to the optional USB communications card.
3. Power up the PC and the indicator. To enter setup mode ([Section 4.0 on page 32](#)).
4. Start the Revolution program.

Revolution provides online help for each of its configuration displays. Parameter descriptions provided in this manual for front panel configuration can also be used when configuring the indicator using Revolution. The interface is different, but the parameters set are the same.

See [Section 6.0 on page 63](#) for more information about using Revolution to configure the 720i.

4.1.2 Serial Command Configuration

The serial command set can be used to configure the 720i indicator using either a PC, terminal or remote keyboard. Like Revolution, serial command configuration sends commands to the indicator serial port; unlike Revolution, serial commands can be sent using external device capable of sending ASCII characters over a serial connection.

Serial commands duplicate the functions available using the indicator front panel and provide some functions not otherwise available. Serial commands can be used to simulate pressing front panel keys, to configure the indicator, or to dump lists of parameter settings. See [Section 11.1 on page 100](#) for more information about using the serial command set.

4.1.3 Front Panel Configuration

By default, the 720i is configured to use the installed single-channel A/D as the source for Scale 1. To configure the 720i for serial scale support, use the Config submenu under the Scales menu.

For example: to configure a serial scale, set the serial input function (SERIAL menu) for Port 4 (or Port 7, if using a serial expansion card) to SCALE or INDUST ([Section 4.2.3 on page 46](#)). Return to the top-level SCALES menu then go **Down** to Scale 1 Configuration, **Right** to CONFIG (Scale Hardware Configuration) then **Down** once more to show the scale source options. Use the **Right** or **Left** navigation key to change the default **A/D** value to **PORT 4** (or **PORT 7**) ([Figure 4-3](#)).

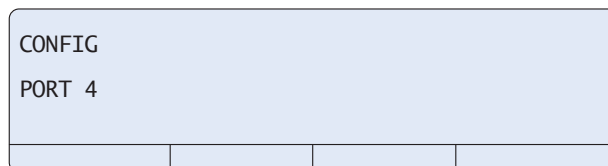

Figure 4-3. Scale Hardware Configuration Display

See [Section 12.3 on page 117](#) for more information about configuring serial scales.

4.1.4 Multi-Range and Multi-Interval Scales

The 720i supports multi-range and multi-interval scales of either two or three ranges or intervals.

Multi-range scales provide two or three ranges, each extending from zero to the maximum capacity specified for the range, that can specify different scale display divisions. The scale interval range changes as the applied weight increases but does not reset to lower range until the scale returns to zero.

Multi-interval scales divide the scale into two or three partial weighing ranges, each with different scale display divisions.

The scale interval changes with both increasing and decreasing loads applied.

To configure a multi-range or multi-interval scale, use the SPLIT parameter to select 2RNG or 3RNG (for multi-range scales), or 2INTVL or 3INTVL (for multi-interval scales). Selecting a SPLIT value other than OFF allows specification of decimal point, display divisions, and maximum capacity for each range or interval.

The SPLIT parameter is used to enable multi-range or multi-interval. The SPLIT parameter is in the SCALES menu ([Figure 4-6 on page 36](#) and [Table 4-3 on page 37](#)). After setting the SPLIT parameter, the Format menu selection changes ([Figure 4-8 on page 43](#), and [Table 4-5 on page 44](#)).

If using streaming with multi-range or multi-interval, the stream must be set to Custom in Revolution. The Tokens for Secondary and Tertiary Units must be set to L or K to match the Primary, refer to the Serial Menu, Tokens Parameter ([Section 4.2.3 on page 46](#)). They can be set using Revolution or through the front panel.

In multi-range, each range has its own capacity and display division, extending from zero. The scale display division increases at the entered range capacities, either two or three ranges. Once the range has increased to the next level, the display division remains in new range until the scale returns to zero. The tare value can be taken at all ranges.

Example: Range 1 is 0 - 3000 x 1 lb; Range 2 is 0 - 10,000 x 5 lb.

In multi-interval, the scale has one capacity, which is segmented into weighing intervals, either two or three intervals, each with different display division sizes. As the weight value exceeds an interval or set interval, the display division increases, as the weight falls below an interval or set interval, the display division decreases. The tare can only be taken in the first interval.

Example: Range 1 is 0-30 x 0.01 lb; Range 2 is 30 - 60 x 0.02 lbs.

4.2 Menu Structures and Parameter Descriptions

The 720i indicator can be configured using a series of menus accessed through the indicator front panel when the indicator is in setup mode. [Table 4-1](#) summarizes the functions of each of the main menus.

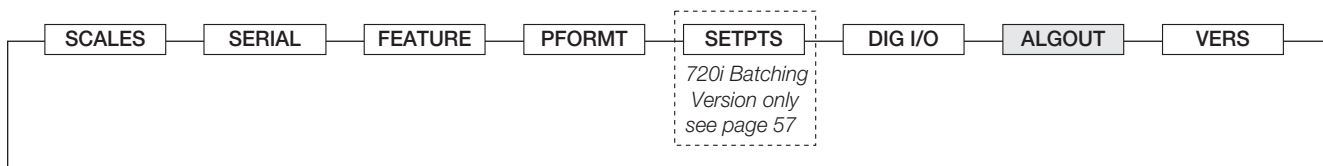

Figure 4-4. 720i Menu

Menu		Menu Function
SCALES	Configuration	Configure and calibrate scale
SERIAL	Serial	Configure communications ports
FEATURE	Feature	Set date and time formats, truck mode, passwords, keyboard locks, regulatory mode, and initial consecutive number value, and define softkeys
PFORMT	Print Format	Set port used for header, gross, net, truck in/out and auxiliary print ticket formats (Section 7.0 on page 65)
SETPTS	Setpoints	Configure setpoints and batching mode; Only available in the 720i Batching version
DIG I/O	Digital I/O	Assign digital input/output functions
ALGOUT	Analog Output	Configure analog output module; Used only if analog output option is installed
VERSION	Version	Display installed software version number; The RSConfig softkey on the Version menu can be used to restore all configuration parameters to their default values

Table 4-1. 720i Menu Summary

The following sections provide graphic representations of the 720i menu structures and tables describing the menu parameters. Default values are shown in **bold** type. Numeric ranges and string values are shown in *italic* type. Parameters shown surrounded by a dotted-line box only appear under the special circumstances explained under each box.

4.2.1 Menu Navigation

Four front panel keys are used as directional keys to navigate through the menus in setup mode (Figure 4-2).

Key	Description
	Move Up
	Move Down
	Access Menu
	Move Left / Previous
	Move Right / Next
	Enter Value

Table 4-2. Front Panel Key Functions

The **Units** and **Tare** keys scroll left and right (horizontally) on the same menu level. **Zero** and **Gross/Net** move up and down (vertically) to different menu levels. The **Print** key serves as an **Enter** key for selecting parameter values within the menus. Press the **Menu** key to show the system menu. A label on each of these keys identifies the direction provided by the key when navigating through the setup menus.

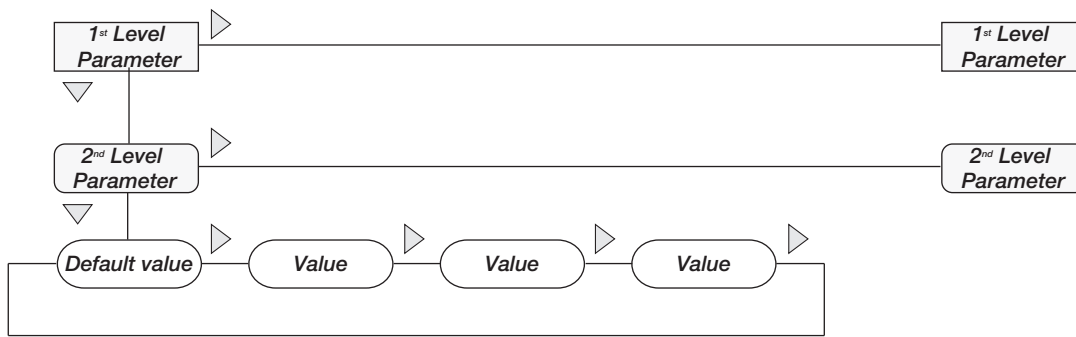







When moving through values below the first menu level, press  to return to the level above. Press  or  to move to the next parameter on the level above.

Figure 4-5. Setup Mode Menu Navigation

To select a parameter, press  or  to scroll left or right until the desired menu group appears on the display then press  to move down to the desired submenu or parameter. When moving through the menu parameters, the default or previously selected value appears first on the display.

4.2.2 SCALES Menu

The SCALES menu is shown in Figure 4-6. The FORMAT submenu is shown in Figure 4-7 on page 39. The CALIBR submenu is shown in Figure 4-9 on page 45. Parameters shown in each diagram are described in the table following that diagram.

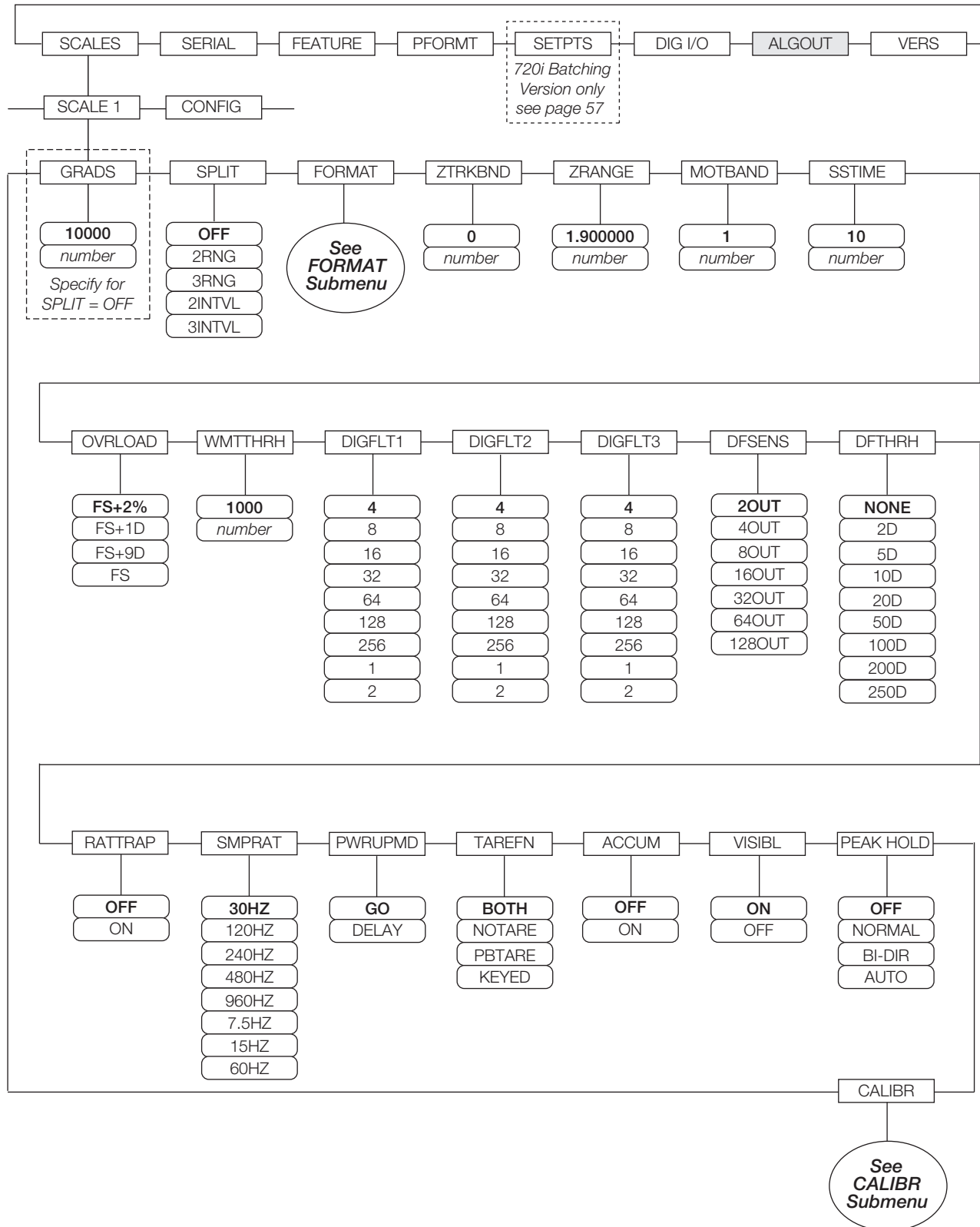

Figure 4-6. SCALES Menu

SCALES Menu		
Parameter	Choices	Description
Level 2 Submenus		
SCALE 1		Allows configuration and calibration of each scale
CONFIG		Scale hardware configuration (A/D or serial scale)
Level 3 Submenus		
GRADS	10000 1–9999999	Specifies the number of full scale graduations if SPLIT=OFF (for multi-range and multi-interval scales (SPLIT = OFF) the GRADS value is derived from the capacity and display divisions specified for the range or interval); The value entered must be in the range 1–9999999 and should be consistent with legal requirements and environmental limits on system resolution; To calculate GRADS, use the formula: $GRADS = \text{Capacity} / \text{Display Divisions}$; Display divisions are specified under the FORMAT submenu
SPLIT	OFF 2RNG 3RNG 2INTVL 3INTVL	Specifies whether the scale is full-range (OFF), multi-range (2RNG, 3RNG), or multi-interval (2INTVL, 3INTVL); For multi-range and multi-interval scales, see the submenu shown in Figure 4-8 on page 43 and parameter descriptions in Table 4-5 on page 44
FORMAT	PRIMAR SECNDR TERTIA ROC	For standard scales (SPLIT=OFF), see Level 4 submenu descriptions in Table 4-4 on page 40 ; For multi-range and multi-interval scales (Table 4-5 on page 44)
ZTRKBND	0 number	Automatically zeroes the scale when within the range specified, as long as the input is within the ZRANGE and scale is at standstill; Specify the zero tracking band in \pm display divisions; Maximum legal value varies depending on local regulations NOTE: For scales using linear calibration, do not set the zero tracking band to a value greater than that specified for the first linearization point.
ZRANGE	1.900000 number	Selects the range within which the scale can be zeroed; The 1.900000 default value is $\pm 1.9\%$ around the calibrated zero point, for a total range of 3.8%. Indicator must be at standstill to zero the scale; Use the default value for legal-for-trade applications
MOTBAND	1 number	Sets the level, in display divisions, at which scale motion is detected; If motion is not detected for 1 second or more, the standstill symbol lights. Some operations, including print, tare, and zero, require the scale to be at standstill; Maximum legal value varies depending on local regulations; If this parameter is set to 0, the standstill annunciator is to be set continuously on, and operations including zero, print and tare is performed regardless of scale motion; If 0 is selected, ZTRKBND must also be set to 0
SSTIME	10 number	Specifies the length of time the scale must be out of motion, in 0.1-second intervals, before the scale is considered to be at standstill; Values greater than 10 are not recommended
OVRLD	FS+2% FS+1D FS+9D FS	Determines the point at which the display blanks and an out-of-range error message is displayed; Maximum legal value varies depending on local regulations
WMTTHR	1000 number	Specifies the minimum number of grads required for a weighment to be added to the recorded number of weighments
DIGFLT1 DIGFLT2 DIGFLT3	4 8 16 32 64 128 256 1 2	Selects the digital filtering rate used to reduce the effects of mechanical vibration from the immediate area of the scale; Choices indicate the number of A/D conversions per update that are averaged to obtain the displayed reading; A higher number gives a more accurate display by minimizing the effect of a few noisy readings, but slows down the settling rate of the indicator NOTE: When configuring non-A/D scales, set the DIGFLTx parameters to 1 to disable filtering. See Section 12.7 on page 122 for more information about digital filtering

Table 4-3. SCALES Menu Parameters

SCALES Menu		
Parameter	Choices	Description
DFSENS	2OUT 4OUT 8OUT 16OUT 32OUT 64OUT 128OUT	Digital filter cutout sensitivity; Specifies the number of consecutive readings that must fall outside the filter threshold (DFTHRH parameter) before digital filtering is suspended; See Section 12.7 on page 122 for more information about digital filtering
DFTHRH	NONE 2D 5D 10D 20D 50D 100D 200D 250D	Digital filter cutout threshold; Specifies the filter threshold, in display divisions; When a specified number of consecutive scale readings (DFSENS parameter) fall outside of this threshold, digital filtering is suspended; If NONE is selected, the filter is always enabled; See Section 12.7 on page 122 for more information about digital filtering
RATTRAP	OFF ON	Enables RATTLETRAP® digital filtering; RATTLETRAP is most effective at filtering repeating vibrations caused by mechanical noise from nearby machines but may increase settling times over standard digital filter selections
SMPRAT	30HZ 60HZ 120HZ 240HZ 480HZ 960HZ 7.5HZ 15HZ	Sample rate. Selects measurement rate, in samples per second, of the analog-to-digital converter; Lower sample rate values provide greater signal noise immunity: the default 120 Hz value may be too fast to provide the desired stability in some static weighing applications
PWRUPMD	GO DELAY	Power up mode; In GO mode, the indicator goes into operation immediately after a brief power up display test; In DELAY mode, the indicator performs a power up display test then enters a 30-second warm up period; If no motion is detected during the warm up period, the indicator becomes operational when the warm up period ends; if motion is detected, the delay timer is reset and the warm up period repeated
TAREFN	BOTH NOTARE PBTARE KEYED	Enables or disables push-button and keyed tares; Possible values are: BOTH: Both push-button and keyed tares are enabled NOTARE: No tare allowed (gross mode only) PBTARE: Push-button tares enabled KEYED: Keyed tare enabled
ACCUM	OFF ON	Accumulator; Specifies whether the scale accumulator is enabled; If enabled, accumulation occurs whenever a print operation is performed
VISIBL	ON OFF	Scale visibility; Specifies whether scale data is displayed
PEAK HOLD	OFF NORMAL BI-DIR AUTO	Peak hold. Used to determine, display, and print the greatest net weight read during a weighing cycle; The weighing cycle ends when a print command is executed (AUTO setting) or when the peak weight is cleared by pressing Zero or Print ; Press Gross/Net to display gross weight data when using the peak hold function: OFF: Peak hold function is off NORMAL: Positive peak, manual reset; Greatest net weight is held in memory until the weight is removed from the scale and either the Zero or Print key is pressed BI-DIR: Bi-directional peak, manual reset; Same as NORMAL, but peak value can be either positive or negative, determined by absolute value AUTO: Positive peak, auto print, auto reset; Automatic print occurs when scale load is 0±10 display divisions and at standstill; Following the print command, the peak value is cleared and reset automatically
CALIBR	WZERO WVAL WSPAN WLIN REZERO	See Level 4 submenu descriptions in Table 4-6 on page 45 and Section 5.2 on page 61

Table 4-3. SCALES Menu Parameters (Continued)

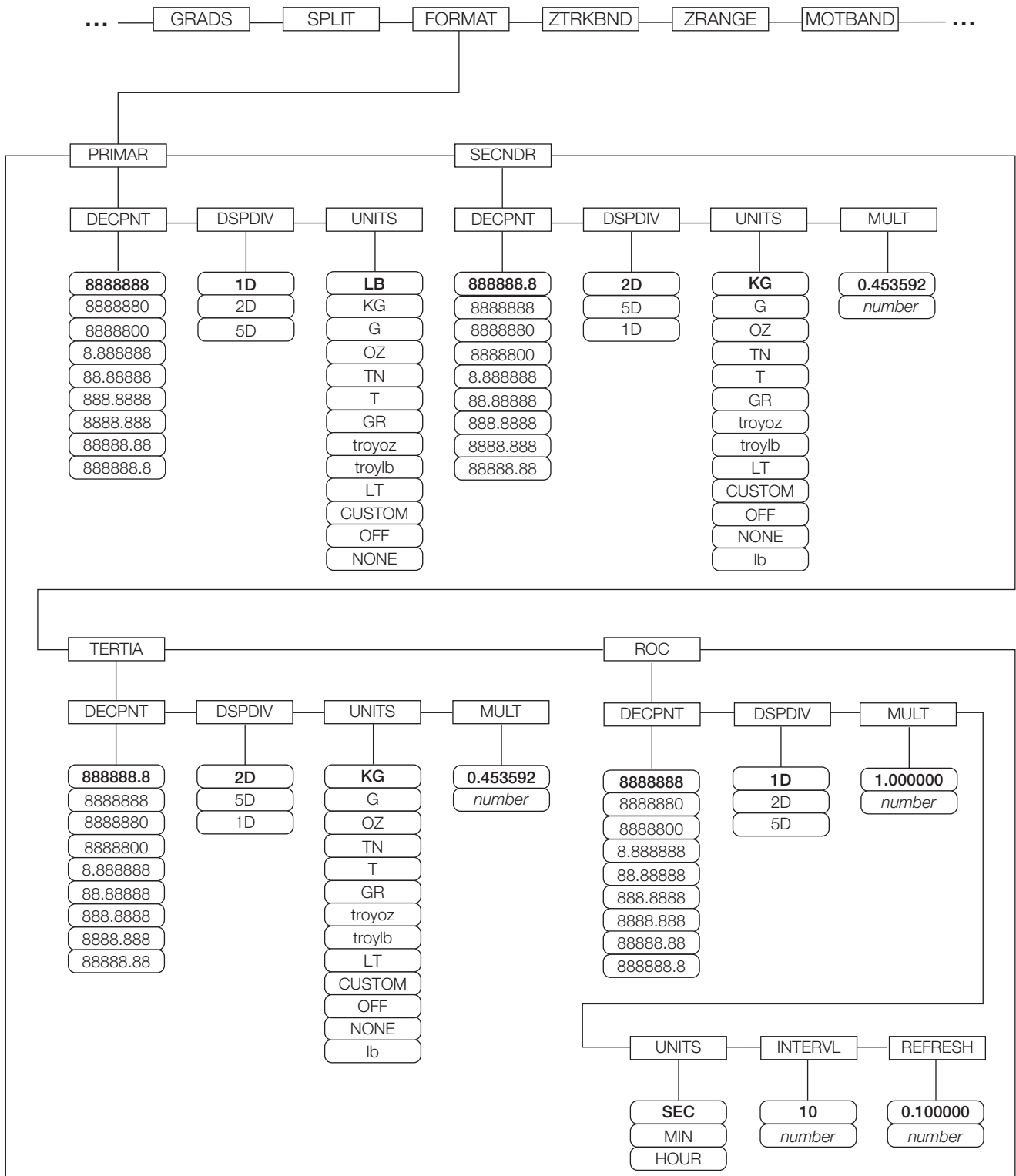

Figure 4-7. SCALES Menu, FORMAT Submenu, SPLIT = OFF

SCALES Menu, FORMAT Submenu, SPLIT = OFF		
Parameter	Choices	Description
Level 4 FORMAT Submenus		
PRIMAR	DECPNT DSPDIV UNITS	Specifies the decimal position, display divisions, and units used for the primary units; See Level 5 submenu parameter descriptions
SECNDR	DECPNT DSPDIV UNITS MULT	Specifies the decimal position, display divisions, units, and conversion multiplier used for the secondary units; See Level 5 submenu parameter descriptions
TERTIA	DECPNT DSPDIV UNITS MULT	Specifies the decimal position, display divisions, units, and conversion multiplier used for the tertiary units; See Level 5 submenu parameter descriptions
ROC	DECPNT DSPDIV MULT TIME INTERVL REFRESH	Specifies the decimal position, display divisions, conversion multiplier, time units, update interval, and refresh interval used for the rate of change units; See Level 5 submenu parameter descriptions
Level 5 Submenus		
Primary Units (PRIMAR) Parameters		
DECPNT	8888888 8888880 8888800 8.888888 88.88888 888.8888 8888.888 88888.88 888888.8	Decimal point location; Specifies the location of the decimal point or dummy zeroes in the primary unit display; Value should be consistent with local legal requirements
DSPDIV	1D 2D 5D	Display divisions; Selects the minimum division size for the primary units displayed weight
UNITS	LB KG G OZ TN T GR TROYOZ TROYLB LT CUSTOM NONE OFF	Specifies primary units for displayed and printed weight; Values are: LB=pound; KG=kilogram; G=gram; OZ=ounce; TN=short ton; T=metric ton; GR=grain; troyoz=troy ounce; troylb=troy pound; LT=long ton

Table 4-4. SCALES Menu, FORMAT Submenu Parameters, SPLIT = OFF

SCALES Menu, FORMAT Submenu, SPLIT = OFF		
Parameter	Choices	Description
Secondary Units (SECNDR) and Tertiary Units (TERTIA) Parameters		
DECPNT	888888.8 8888888 8888880 8888800 8.888888 88.88888 888.8888 8888.888 88888.88	Decimal point location; Determines the location of the decimal point or dummy zeros in the secondary or tertiary units display
DSPDIV	5D 1D 2D	Display divisions; Selects the value of minimum division size of the displayed weight for secondary or tertiary units display
UNITS	KG G OZ TN T GR troyoz troylb LT CUSTOM OFF NONE LB	Specifies secondary or tertiary units for displayed and printed weight; Values are: LB=pound; KG=kilogram; G=gram; OZ=ounce; TN=short ton; T=metric ton; GR=grain; troyoz=troy ounce; troylb=troy pound; LT=long ton
MULT	0.453592 0.000001– 9999999	Multiplier. Specifies the conversion factor by which the primary units are multiplied by to obtain the secondary or tertiary units; The default is 0.453592, which is the conversion factor for changing pounds to kilograms; See Section 12.8 on page 123 for a list of multipliers; To shift between primary, secondary, and tertiary units, press the Units key
Rate of Change (ROC) Units Parameters		
<p>For applications using the ROC function, the primary scale should be configured with a finer resolution than the rate of change (ROC) units to prevent a stepwise appearance in the ROC display; The ROC display step size (weight increment between displayed values) can be roughly calculated as follows: (updates_per_ROC_UNIT) * (PRIMARY_resolution / ROC_resolution); For example, with INTERVL=30; REFRESH =0.1; UNITS=MIN; PRIMARY resolution at 0.1 LB and ROC resolution at 1.0 (LB/MIN):</p> <ul style="list-style-type: none"> -INTERVL * REFRESH = 30 * 0.1 = 3.0 seconds per update (ROC data is flushed every 3.0 seconds) -With UNITS = MIN, there are 20 ROC data updates per ROC time unit: 60 seconds / 3.0 seconds per update -The resolution ratio of PRIMARY to ROC units is 0.1 (0.1 / 1.0) -This configuration provides a step size in the ROC display of 2 LB (2 LB increments between displayed values): 20 * 0.1 = 2 <p>The setting both PRIMARY and ROC display resolutions to 1 LB would have resulted in a step size of 20 LB</p>		
DECPNT	8888888 8888880 8888800 8.888888 88.88888 888.8888 8888.888 88888.88 888888.8	Decimal point location; Determines the location of the decimal point or dummy zeros in the display
DSPDIV	1D 2D 5D	Display divisions; Selects the minimum division size for the ROC units displayed weight

Table 4-4. SCALES Menu, FORMAT Submenu Parameters, SPLIT = OFF (Continued)

SCALES Menu, FORMAT Submenu, SPLIT = OFF		
Parameter	Choices	Description
MULT	1.0 0.000001– 9999999	Multiplier; Specifies the conversion factor by which the primary units are multiplied by to obtain the displayed rate of change units; See Section 12.8 on page 123 for information about conversion factors
UNITS	SEC MIN HOUR	Rate-of-change units
INTERVL	10 1–100	Update interval. Specifies the number of refreshes over which the rate-of-change is calculated; For example, with REFRESH set to 0.1 second and INTERVL at 60, each weight value takes 6 seconds (0.1 * 60) to be flushed from the ROC data
REFRESH	0.1 0.1–60	Refresh interval; Specifies the number of seconds between rate-of-change samples

Table 4-4. SCALES Menu, FORMAT Submenu Parameters, SPLIT = OFF (Continued)

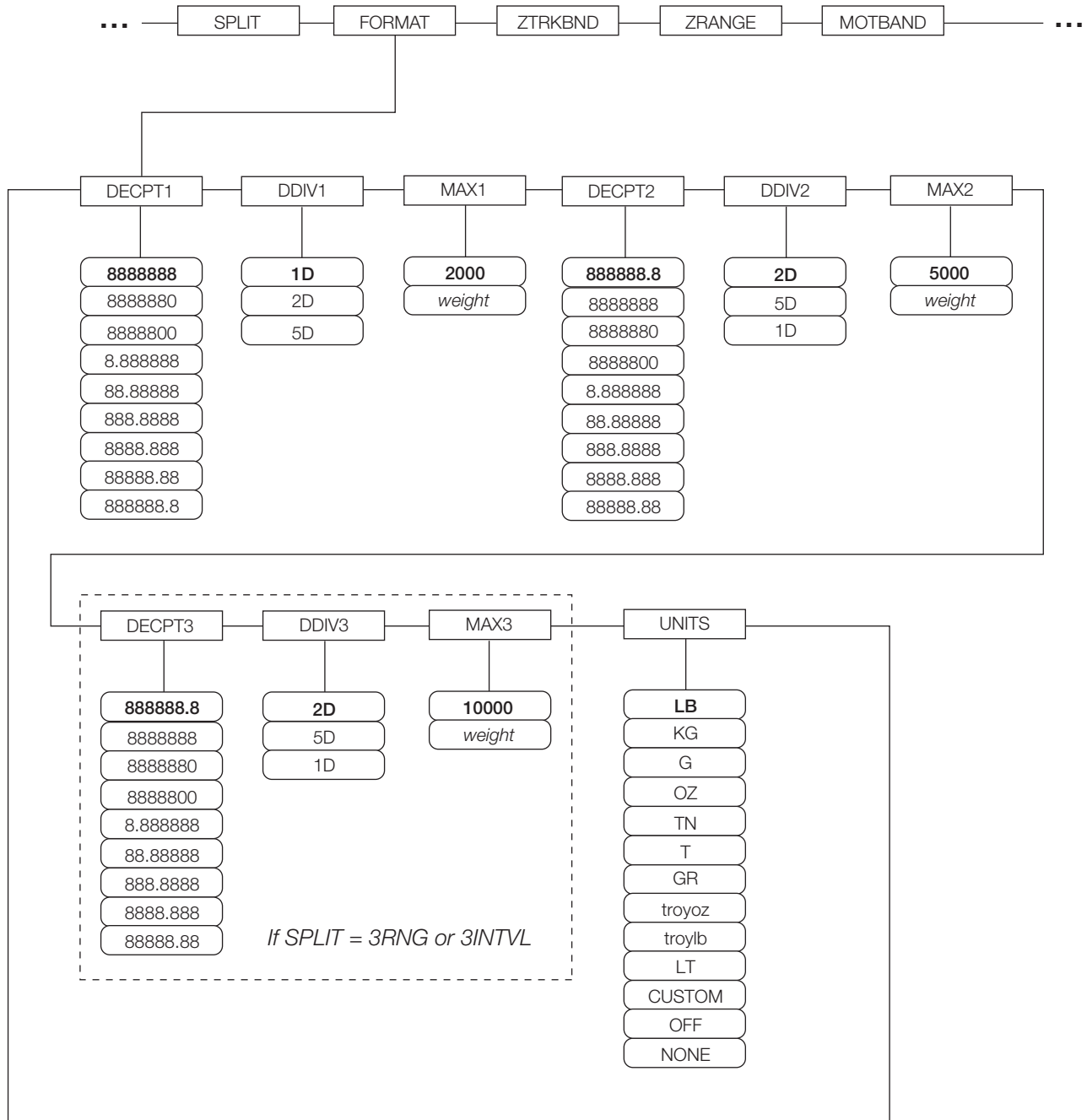

Figure 4-8. **FORMAT** Submenu, **SPLIT** ≠ **OFF** (Multi-range and Multi-interval Scales)

SCALES Menu, FORMAT Submenu, SPLIT ≠ OFF		
Parameter	Choices	Description
Level 4 FORMAT Submenus		
DECPT1	8888888 8888880 8888800 8.888888 88.88888 888.8888 8888.888 88888.88 888888.8	Decimal point location for first range or interval; Specifies the location of the decimal point or dummy zeros in the primary unit display; Value should be consistent with local legal requirements
DDIV1	1D 2D 5D	Display divisions for first range or interval; Selects the minimum division size for the primary units displayed weight
MAX1	2000 <i>weight</i>	Maximum weight for first range or interval
DECPT2	888888.8 8888888 8888880 8.888888 88.88888 888.8888 8888.888 88888.88	Decimal point location for second range or interval; Specifies the location of the decimal point or dummy zeroes in the primary unit display; Value should be consistent with local legal requirements
DDIV2	2D 5D 1D	Display divisions for second range or interval; Selects the minimum division size for the primary units displayed weight
MAX2	5000 <i>weight</i>	Maximum weight for second range or interval
DECPT3	888888.8 8888888 8888880 8888800 8.888888 88.88888 888.8888 8888.888 88888.88	Decimal point location for third range or interval (SPLIT = 3RNG or 3INTVL only); Specifies the location of the decimal point or dummy zeroes in the primary unit display; Value should be consistent with local legal requirements
DDIV3	2D 5D 1D	Display divisions for third range or interval (SPLIT = 3RNG or 3INTVL only); Selects the minimum division size for the primary units displayed weight
MAX3	10000 <i>weight</i>	Maximum weight for third range or interval (SPLIT = 3RNG or 3INTVL only)
UNITS	LB KG G OZ TN T GR troyoz troylb LT CUSTOM NONE OFF	Specifies primary units for displayed and printed weight; Values are: LB=pound; KG=kilogram; G=gram; OZ=ounce; TN=short ton; T=metric ton; GR=grain; troyoz=troy ounce; troylb=troy pound; LT=long ton

Table 4-5. SCALES Menu, FORMAT Submenu Parameters, SPLIT ≠ OFF

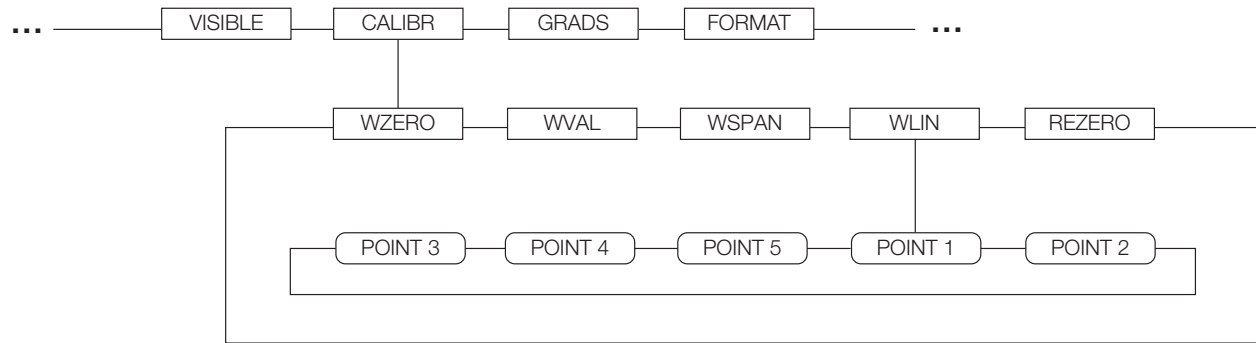

Figure 4-9. SCALES Menu, CALIBR Submenu

SCALES Menu, CALIBR Submenu		
Parameter	Choices	Description
Level 4 CALIBR Submenus		
WZERO	—	Press Enter to display and edit the zero calibration A/D count or millivolts value
WVAL	—	Press Enter to display and edit the test weight value NOTE: If unable to change value using keypad, use the following method to enter new value: To enter new value use the up/down keys to change the first digit to desired number then use the keypad to enter the rest of the numbers. Example: To enter 25000 change the first number using up/down arrows to 2 then use the keypad and enter 5000. The result is 25000.
WSPAN	—	Press Enter to display and edit the span calibration A/D count or millivolts value
WLIN	POINT 1 — POINT 5	Press Enter to display and edit test weight and calibration values for up to five linearization points; Perform linear calibration only after WZERO and WSPAN have been set
REZERO	—	Press Enter to remove an offset value from the zero and span calibrations NOTE: Use this parameter only after WZERO and WSPAN have been set. See Section 5.2 on page 61 for more information about using this parameter.

Table 4-6. SCALES Menu, CALIBR Submenu Parameters

4.2.3 SERIAL Menu

See Section 12.6 on page 121 for information about 720i serial data formats.

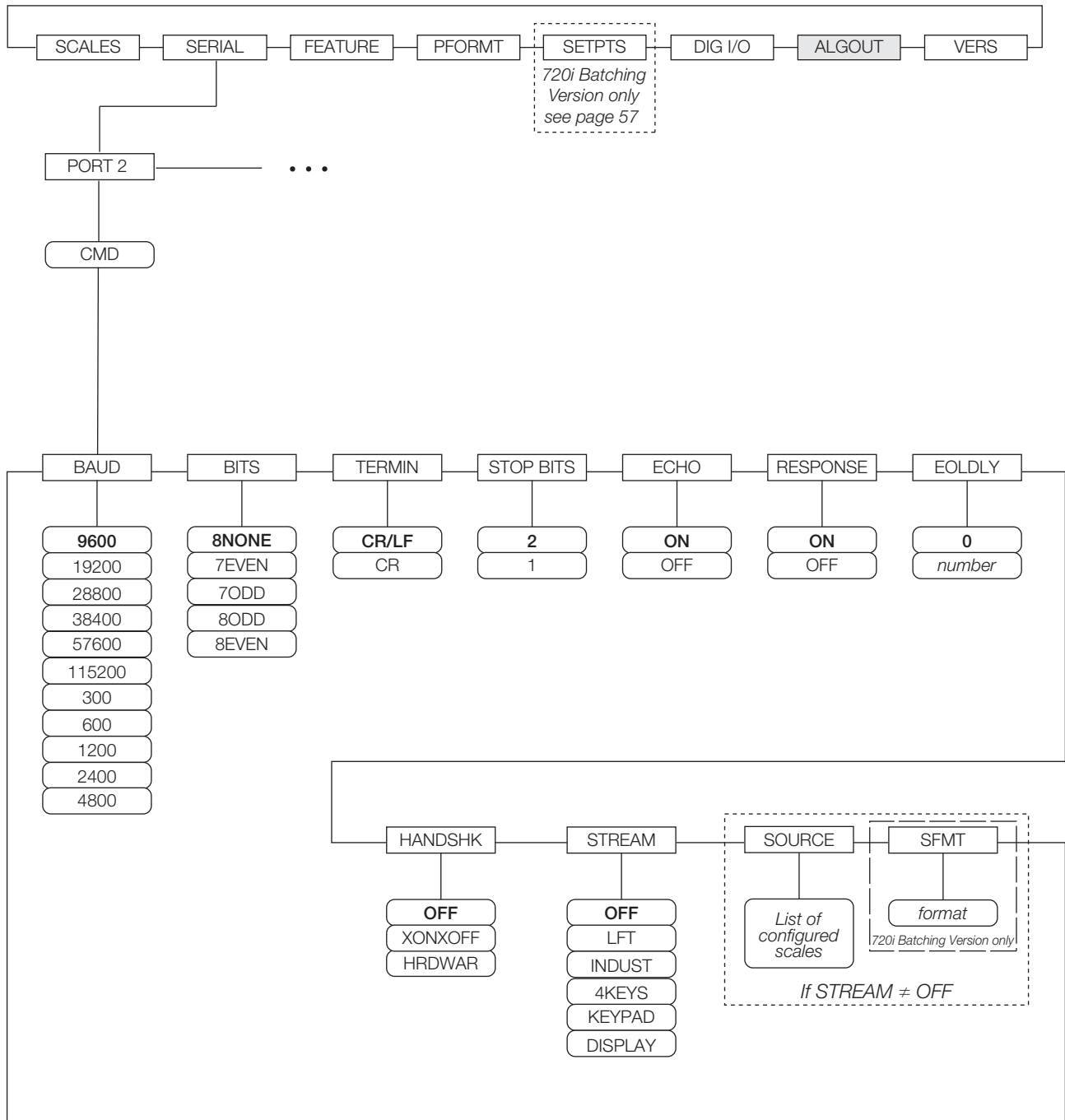

Figure 4-10. SERIAL Menu, Port 2

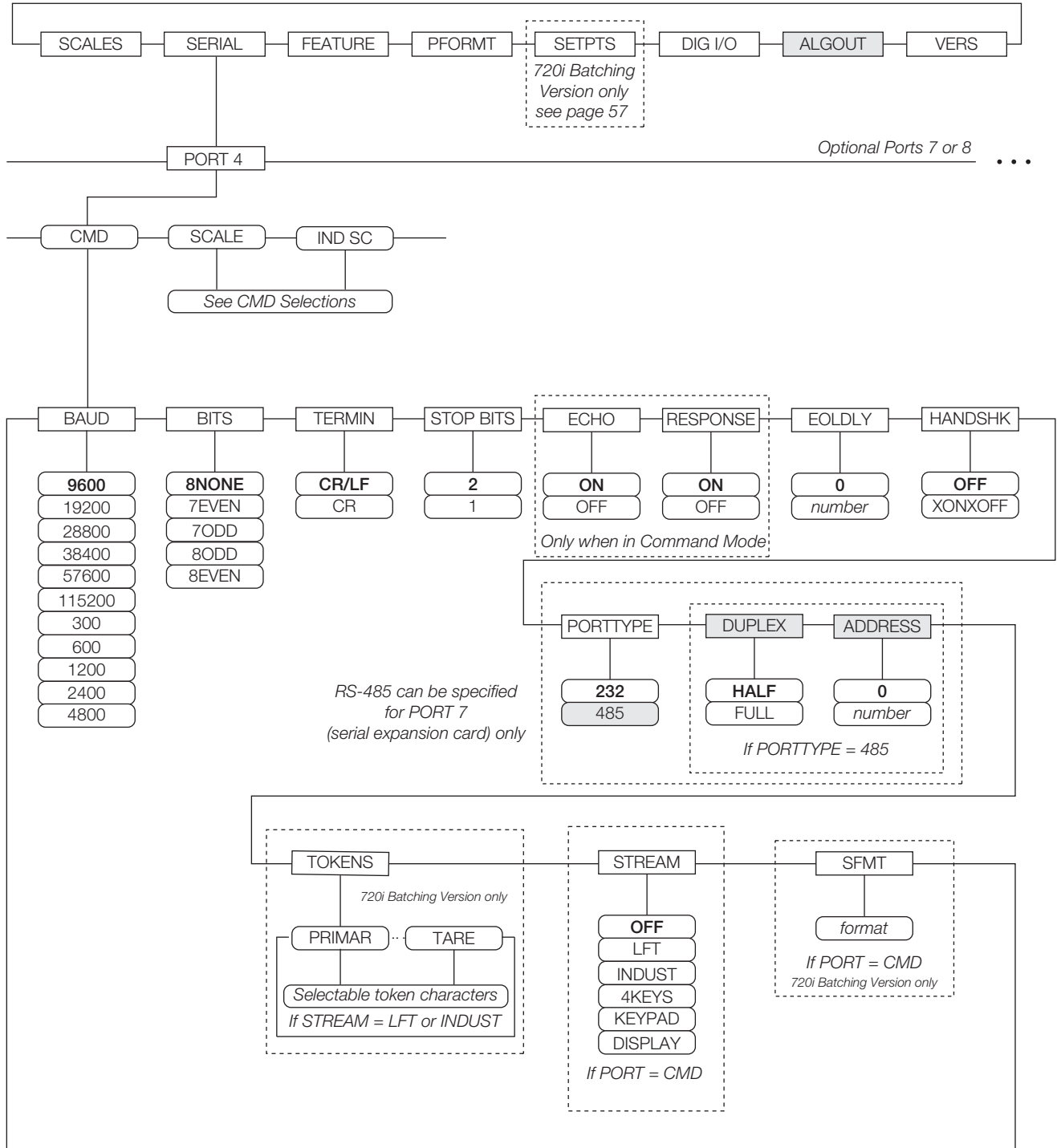

Figure 4-11. SERIAL Menu, Port 4 and Expansion Ports

SERIAL Menu		
Parameter	Choices	Description
Level 2 Submenus		
PORT 2 PORT 4	CMD SCALE IND SC	Specifies the type of data received by the port: SCALE:Legal-for-trade serial scale input IND SC:Industrial (non-legal-for-trade) scale input KEYBD is available only on Port 1; SCALE, IND SC are available only on Port 4 and higher (expansion ports) NOTE: The keyboard interface is not hot-pluggable. Power-off the 720i before attaching keyboard cable to the Port 1 connector. Do not edit Port 3 parameters. Port 3 provides communications with the detached display module (DDM); changing these parameters disable the display. Print format outputs default to Port 4; if using Port 4 for other scale connections, reassign needed print formats to another port before configuring.
Level 3 Submenus		Ports 2 and 4
BAUD	9600 19200 28800 38400 57600 115200 300 600 1200 2400 4800	Baud rate; Selects the transmission speed for the port NOTE: The maximum baud rate for ports on serial expansion cards (port number greater than 4) is 19200.
BITS	8NONE 7EVEN 7ODD 8ODD 8EVEN	Selects number of data bits and parity of data transmitted or received by the port
STOP BITS	2 1	Selects number of stop bits transmitted or received by the port
ECHO	ON OFF	Specifies whether characters received by the port are echoed back to the sending unit
RESPONSE	ON OFF	Specifies whether the port transmits replies to serial commands
TERMIN	CR/LF CR	Termination character; Selects termination character for data sent from the port
EOLDLY	0 0-255	End-of-line delay; Sets the delay period, in 0.1-second intervals, from when a formatted line is terminated to the beginning of the next formatted serial output; Value specified must be in the range 0-255, in tenths of a second (10 = .1 second)
HANDSHK	OFF XONOFF HRDWAR	Specifies whether XON/XOFF flow control characters or hardware handshaking is used; Hardware handshaking is available only on Port 2
PORTTYPE	232 485	Specifies whether the port is used for RS-232 or RS-485 communications; If 485 is selected (Port 7 only), additional prompts are shown to specify half- or full-duplex operation and RS-485 address NOTE: RS-485 communications can be specified for Port 7 (serial expansion card) only.
DUPLEX	HALF FULL	Specifies whether the RS-485 communications is half- or full-duplex
ADDRESS	0 0-255	Specifies the decimal indicator address for RS-485 connections; RS-232 communications is disabled if an address other than zero is specified for this parameter; RS-485 addresses must be in the range 01-255

Table 4-7. Serial Menu Parameters

SERIAL Menu		
Parameter	Choices	Description
TOKENS	PRIMAR SECNDR TERTIA GROSS INVALID MOTION ZERO NET OK RANGE TARE	If STREAM is set to LFT or INDUST, the TOKENS parameter can be used to replace tokens used in the data stream from the indicator front panel; See Section 12.5 on page 119 for more information about custom stream formatting
STREAM	OFF LFT INDUST 4KEYS KEYPAD	Specifies what data, if any, is streamed from the port; LFT updates streamed data at the display rate, so only weight values shown on the display are streamed; INDUST streams data at the A/D update rate specified by the SMPRATE parameter on the SCALES menu (Section 4.2.2 on page 36); 4KEYS and KEYPAD stream keypad events to a receiving indicator; KEYPAD transmits all keypad events; 4KEYS transmits key presses of the Zero , Gross/Net , Tare , and Units keys only NOTE: Streaming is not supported for RS-485 connections. The print key always prints locally.
SFMT	Format	Specifies the stream format used for the streamed data (CMD scale type); The default format is the Rice Lake format (Section 12.6 on page 121); See Section 12.5 on page 119 for information about custom stream formatting

Table 4-7. Serial Menu Parameters (Continued)

4.2.4 FEATURE Menu

The FEATURE menu is used to set miscellaneous system attributes, including time and date, truck mode, softkey definitions, and parameters relating to the regulatory environment. See [Table 4-8 on page 51](#) for parameter descriptions.

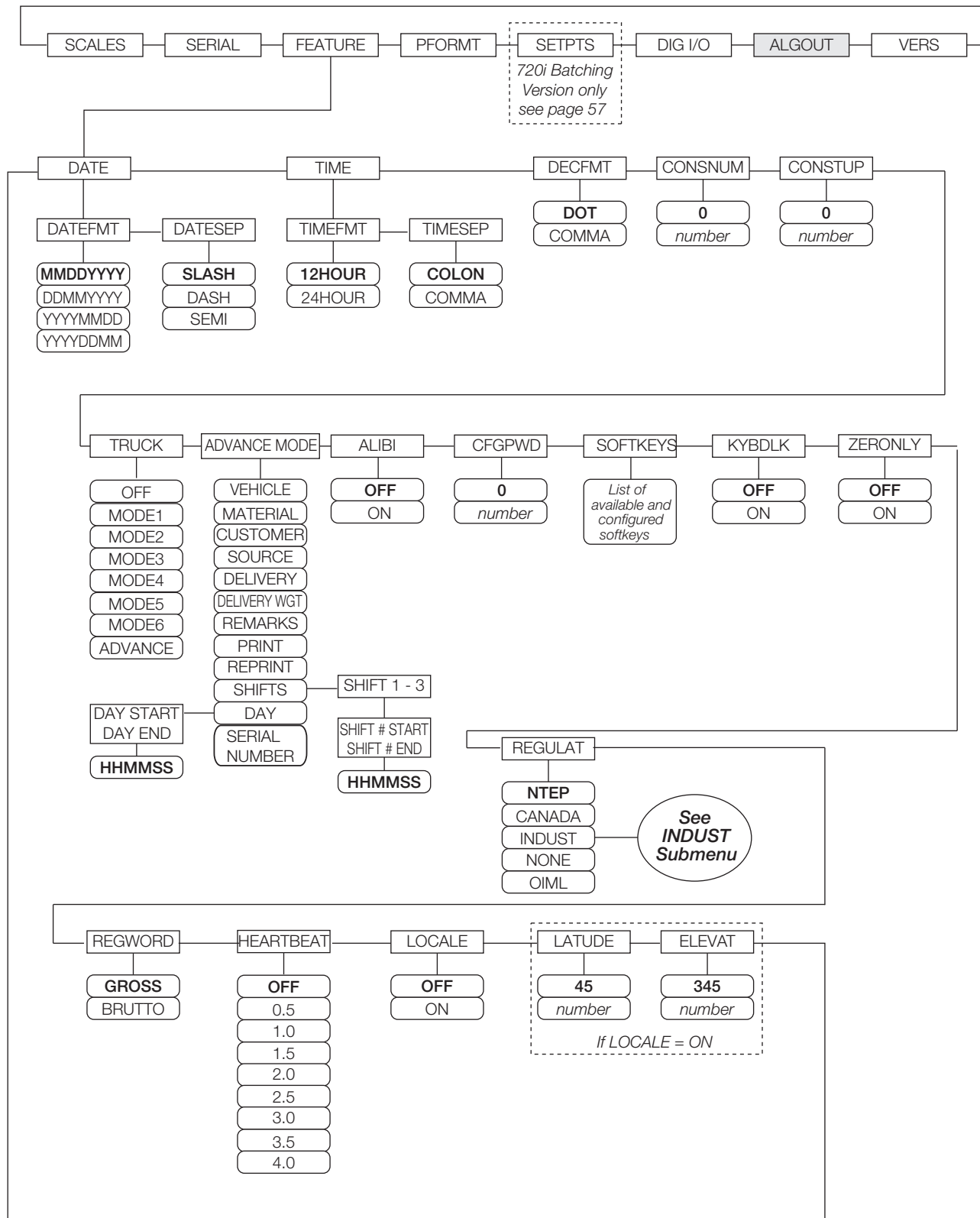

Figure 4-12. FEATURE Menu

FEATURE Menu		
Parameter	Choices	Description
Level 2 Submenus		
DATE	DATEFMT DATESEP	Allows selection of date format and date separator character; See Level 3 submenu parameter descriptions; Use the Time/Date softkey or the SD serial command to set the date; See Section 11.0 on page 100 for information about using the serial commands
TIME	TIMEFMT TIMESEP	Allows selection of time format and separator character; See Level 3 submenu parameter descriptions; Use the Time/Date softkey or the ST serial command to set the time; See Section 11.1 on page 100 for information about using the serial commands
DECFMT	DOT COMMA	Specifies whether decimal numbers are displayed using a period (DOT) or comma as the decimal symbol
CONSNUM	0 0-9999999	Consecutive numbering; Allows sequential numbering for print operations; The consecutive number value is incremented following each print operation that includes <CN> in the ticket format; When the consecutive number is reset, it is reset to the value specified on the CONSTUP parameter
CONSTUP	0 0-9999999	Specifies the consecutive number start-up value used when the consecutive number is reset by sending the KCLRCN serial command or a CLRCN digital input; Value specified must be in the range 0-9999999
TRUCK	OFF MODE1 MODE2 MODE3 MODE4 MODE5 MODE6 ADVANCE	Specifies the truck mode used; If selected, the indicator switches from normal mode to the selected truck mode; See Section 8.0 on page 71 for more information about using the truck modes: MODE1: Auto clear ID, keyed tares, value swapping MODE2: Auto clear ID, no keyed tares, value swapping MODE3: Stored ID, keyed tares, value swapping MODE4: Stored ID, no keyed tares, value swapping MODE5: Stored ID, keyed tares, no value swapping MODE6: Stored ID, no keyed tares, no value swapping ADVANCE: Enables the advance mode NOTE: Modes 1 - 6 have stored tare weight by Truck ID, Advance mode does not have stored tare weight, only stored transactions.
ADVANCE MODE	VEHICLE MATERIAL CUSTOMER SOURCE DELIVERY DELIVERY WGT REMARKS PRINT REPRINT SHIFTS DAY SERIAL NUMBER	ON or OFF, default is ON ON or OFF, default is ON ON or OFF, default is ON ON or OFF, default is ON ON or OFF, default is ON ON or OFF, default is ON ON or OFF, default is ON ON, OFF or PROMPT, default is ON ON or OFF SHIFT 1, SHIFT 2, SHIFT 3 DAY START, DAY END Enter Serial Number (Ticket Serial Number) 0-99999999 (Default is 0); See Table 8-2 on page 73 for more information on each prompt
ALIBI	OFF ON	Specifies whether data storage is used by the alibi feature to allow reprinting transactions; Use the SOFTKEYS parameter to enable a softkey for recalling alibi print transactions; See Section 12.11 on page 126 for more information about using the alibi feature
CFGPWD	0 0-9999999 reset=999999	Configuration password; Specify a non-zero value to restrict access to all configuration menus and PCE NOTE: If a configuration password is specified, be sure to record the password and keep it in a safe place. If the configuration password is lost or unavailable, the indicator must be cleared (reset configuration and calibration parameters) to continue use. To clear the indicator, press the setup switch then enter 999999 (six nines) at the configuration password prompt. The unit performs a RESETCONFIGURATION then returns to the setup mode configuration display.
KYBDLK	OFF ON	Keyboard lock; Specify ON to disable the keypad in normal mode
ZERONLY	OFF ON	Zero key only; Specify ON to disable all front panel keys except ZERO in normal mode

Table 4-8. FEATURE Menu Parameters

FEATURE Menu		
Parameter	Choices	Description
SOFTKEYS	None <blank> Time/Date Display Tare Display Accum Display ROC Alibi	Softkeys provide additional operator functions for specific applications; Assignments are listed on the tabs shown at the bottom of the LCD display; Functions are activated by pressing the arrow keys below the softkey tabs
	Setpoint Batch Start Batch Stop Batch Pause Batch Reset	These features are only available with the 720i Batching version software
	Weigh Reports Management	These features are available with the Advanced Truck Mode Only
	Weigh In Weigh Out Truck Regs	These features are available with the Truck Modes 1-6 Only
SKUD	1-10	User-programmable softkeys; defined by PCEE
REGULAT	NTEP CANADA INDUST NONE OIML	Regulatory mode. Specifies the regulatory agency having jurisdiction over the scale site; OIML, NTEP, and CANADA modes allow a tare to be acquired at weights greater than zero; NONE allows tares to be acquired at weight values; OIML, NTEP, and CANADA modes allow a tare to be cleared only if the gross weight is at no load; NONE allows tares to be cleared at weight values; NTEP and OIML modes allow a new tare to be acquired even if a tare is already present; In CANADA mode, the previous tare must be cleared before a new tare can be acquired; NONE, NTEP and CANADA modes allow the scale to be zeroed in either gross or net mode as long as the current weight is within the specified ZRANGE; In OIML mode, the scale must be in gross mode before it can be zeroed; pressing the Zero key in net mode clears the tare; INDUST provides a set of sub-parameters to allow customization of tare, clear, and print functions in non-legal-for-trade scale installations; See Level 4 parameter descriptions in Table 4-9 on page 54 ; The value specified for this parameter affects the function of the front panel Tare and Zero keys; See Section 12.2 on page 116 for a complete description of Tare and Zero key functions for each of the regulatory modes
REGWORD	GROSS BRUTTO	Sets the term displayed when weighing in gross mode; Selecting BRUTTO replaces the Gross annunciator with Brutto
HEARTBEAT	OFF, 0.5—4.0	Specifies, in seconds, the rate of the heartbeat signal sent from the host to the display module; The heartbeat is used to verify active communications between the host and the display and to ensure that the displayed data is current; If specified, the display module input heartbeat (HB1:I parameter) must also be set, typically to a value slightly longer than the host HEARTBEAT parameter (for example, HEARTBEAT=1.5, HB1:I=2.0.); See Section 12.10 on page 125 for more information about configuring the display module
LOCALE	OFF ON	Locale; Set this parameter ON to enable the LATUDE and ELEVAT parameters; Specifying latitude and elevation of the scale site provides compensation for gravitational effects; Attached scales must be recalibrated after changing this parameter from OFF to ON
LATUDE	45 0—90	Latitude. Specify the latitude of the scale site in degrees; This parameter is shown only if LOCALE=ON
ELEVAT	345 ±0—9999	Elevation; Specify the elevation of the scale site in meters; Valid values are -9999—9999; This parameter is shown only if LOCALE=ON
Level 3 Submenus		

Table 4-8. FEATURE Menu Parameters (Continued)

FEATURE Menu		
Parameter	Choices	Description
DATEFMT	MMDDYYYY DDMMYYYY YYYYMMDD YYYYDDMM	Specifies the format used to display or print the date
DATESEP	SLASH DASH SEMI	Specifies the date separator character
TIMEFMT	12HOUR 24HOUR	Specifies the format used to display or print the time
TIMESEP	COLON COMMA	Specifies the time separator character
SHIFT 1 - 3	SHIFT # START SHIFT # END	Specifies the shift start and end time in 24 hour format (HHMMSS)
DAY START DAY END	HHMMSS HHMMSS	Specifies the day start and end time in 24 hour format (HHMMSS)

Table 4-8. FEATURE Menu Parameters (Continued)

FEATURE Menu, REGULAT/INDUST Submenu

The INDUST setting of the REGULAT parameter allows customization of several tare, clear, and print functions for use in **non-legal-for-trade** scale installations. See [Section 12.2 on page 116](#) for more information about regulatory mode functions.

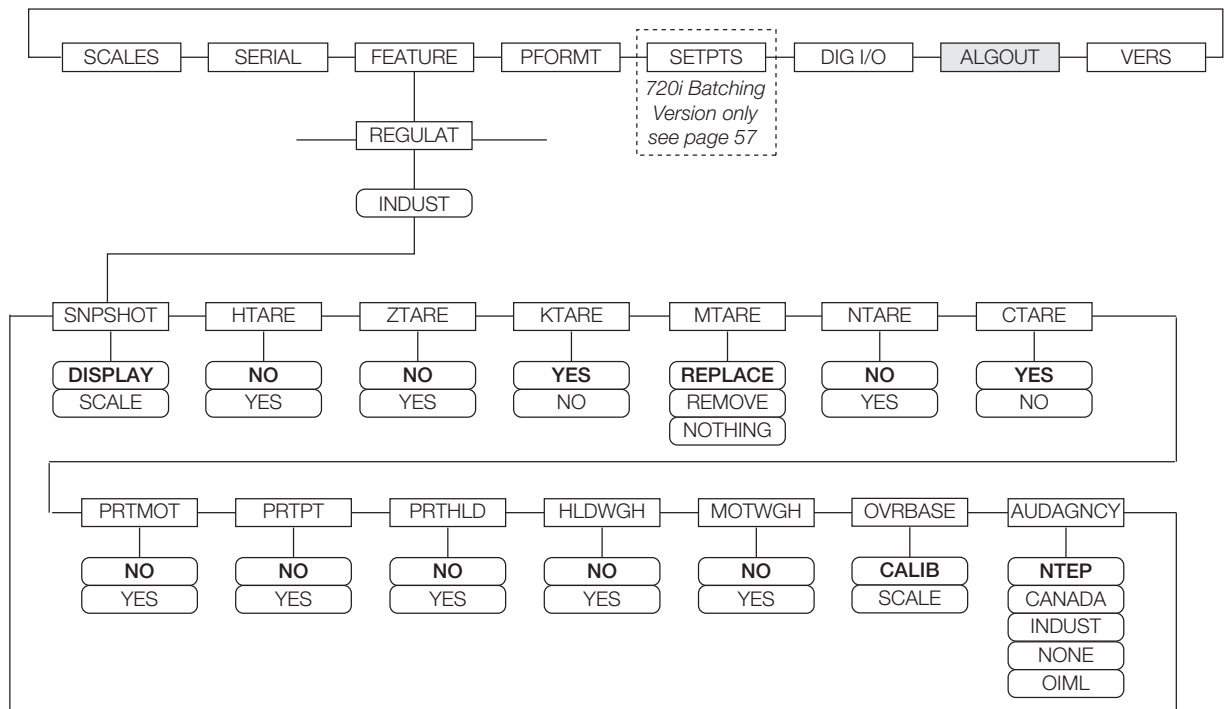

Figure 4-13. REGULAT / INDUST Submenu

FEATURE Menu, REGULAT / INDUST Submenu		
Parameter	Choices	Description
Level 4 REGULAT / INDUST Submenus		
SNPSHOT	DISPLAY, SCALE	Display or Scale weight source
HTARE	NO, YES	Allow tare in display hold
ZTARE	NO, YES	Remove tare on Zero
KTARE	YES, NO	Always allow keyed tare
MTARE	REPLACE REMOVE NOTHING	Multiple tare action
NTARE	NO, YES	Allow negative or zero tare
CTARE	YES, NO	Allow Clear key to clear tare/accumulator
PRTMOT	NO, YES	Allow print while in motion
PRTPT	NO, YES	Add PT to keyed tare print
PRTHLD	NO, YES	Print during display hold
HLDWGH	NO, YES	Allow truck weighment during display hold
MOTWGH	NO, YES	Allow truck weighment in motion
OVRBASE	CALIB, SCALE	Zero base for overload calculation
AUDAGNCY	NTEP CANADA INDUST NONE OIML	Audit trail display agency format

Table 4-9. REGULAT / INDUST Submenu Parameters

4.2.5 PFORMT Menu

The PFORMT menu can be used to set the port used by each print format. Print formats can be viewed or edited using Revolution, serial commands or the front panel. See [Section 7.0 on page 65](#) for detailed information about print formatting.

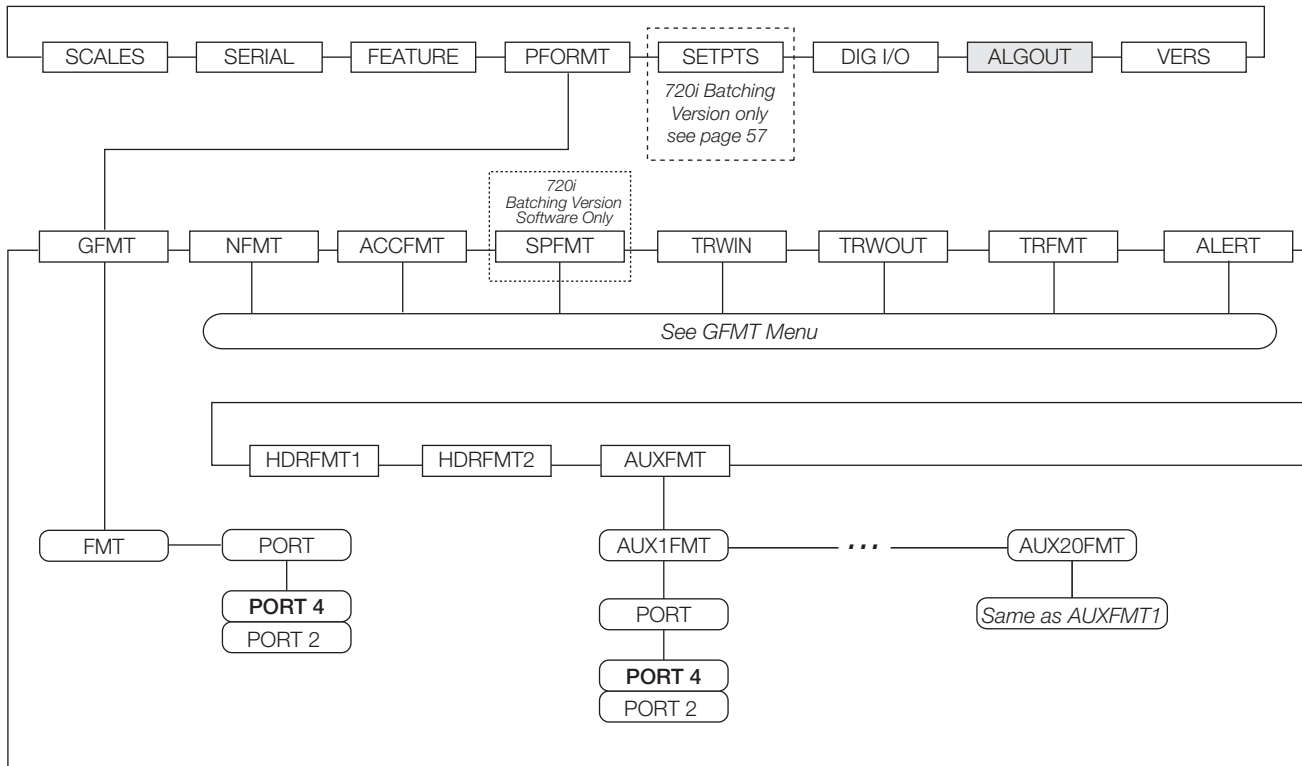

Figure 4-14. PFORMT Menu

4.2.6 DIG I/O Menu

The DIG I/O menu shown in Figure 4-15 is used to assign functions to digital inputs and outputs. SLOT 0 represents the eight I/O bits available on the CPU board (connector J6). The additional slot, with 24 I/O bits, is shown only if the digital I/O expansion card is installed.

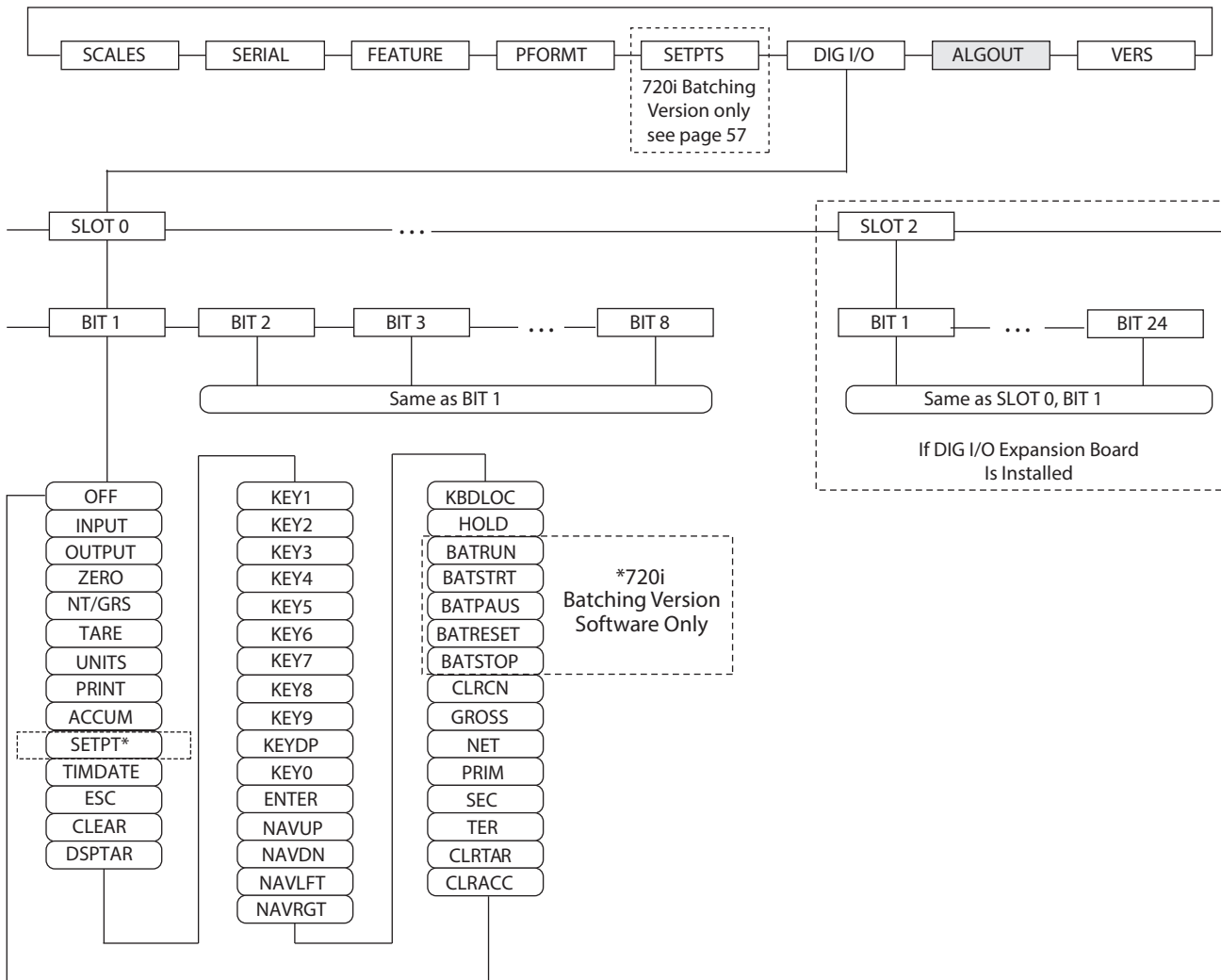

Figure 4-15. DIG I/O Menu

DIG I/O Menu		
Parameter	Choices	Description
Level 2 Submenus		
SLOTx	BIT y	Lists available digital I/O slots
Level 3 Submenus		
BIT y	OFF INPUT OUTPUT ZERO NT/GRS TARE UNITS PRINT ACCUM SETPTS TIMDATE ESC CLEAR DSPTAR KEY0—KEY9 KEYDP ENTER NAVUP NAVDN NAVLFT NAVRGT KBDLOC HOLD *BATRUN *BATSTRT *BATPAUS *BATRESET *BATSTOP CLRCN GROSS NET PRIM SEC TER CLRTAR CLRACC	Specifies the function of the digital I/O bit <ul style="list-style-type: none"> • OFF indicates that the bit is not configured • INPUT assigns the bit as a digital input • OUTPUT assigns the bit as a digital output • ZERO, NT/GRS (net/gross mode toggle), TARE, UNITS, and PRINT provide the same functions as the five major front panel keys • ACCUM, SETPTS and TIMDATE provide the same function as the Display Accum, Setpoint and Time/Date softkeys • ESC provides a function equivalent to the Cancel softkey • CLEAR simulates pressing the front panel CLR key • DSPTAR displays the current tare; equivalent to pressing the Display Tare softkey • KEY0—KEY9 and KEYDP (decimal point) simulate pressing keys on the numeric keypad • ENTER simulates pressing the front panel Enter key • NAVUP, NAVDN, NAVLFT, and NAVRGT simulate pressing the navigation keys • KBDLOC locks the keyboard (indicator front panel) when held low • HOLD holds the current display; Releasing this input clears the running average filter • BATRUN allows a batch routine to be started and run; With BATRUN active (low), the BATSTRT input starts the batch; if BATRUN is inactive (high), BATSTRT resets the batch • BATSTRT starts or resets a batch routine, depending on the state of the BATRUN input • BATPAUS pauses a batch routine when held low • BATRESET stops the batch sequence and resets to the first batch step • BATSTOP stops the batch routine • CLRCN resets the consecutive number to the value specified on the CONSTUP parameter (FEATURE menu) • GROSS, NET, PRIM, SEC, and TER select gross or net weight display, and primary, secondary, or tertiary units display modes • CLRTAR clears the current tare for the active scale • CLRACC clears the active accumulator
* 720i Batching Software Version Only		

Table 4-10. DIG I/O Menu Parameters

4.2.7 ALGOUT Menu

If the analog output option is installed, configure all other indicator functions and calibrate the indicator itself before configuring the analog output. See the Analog Output Card Installation Instructions, PN 69089, for more information.

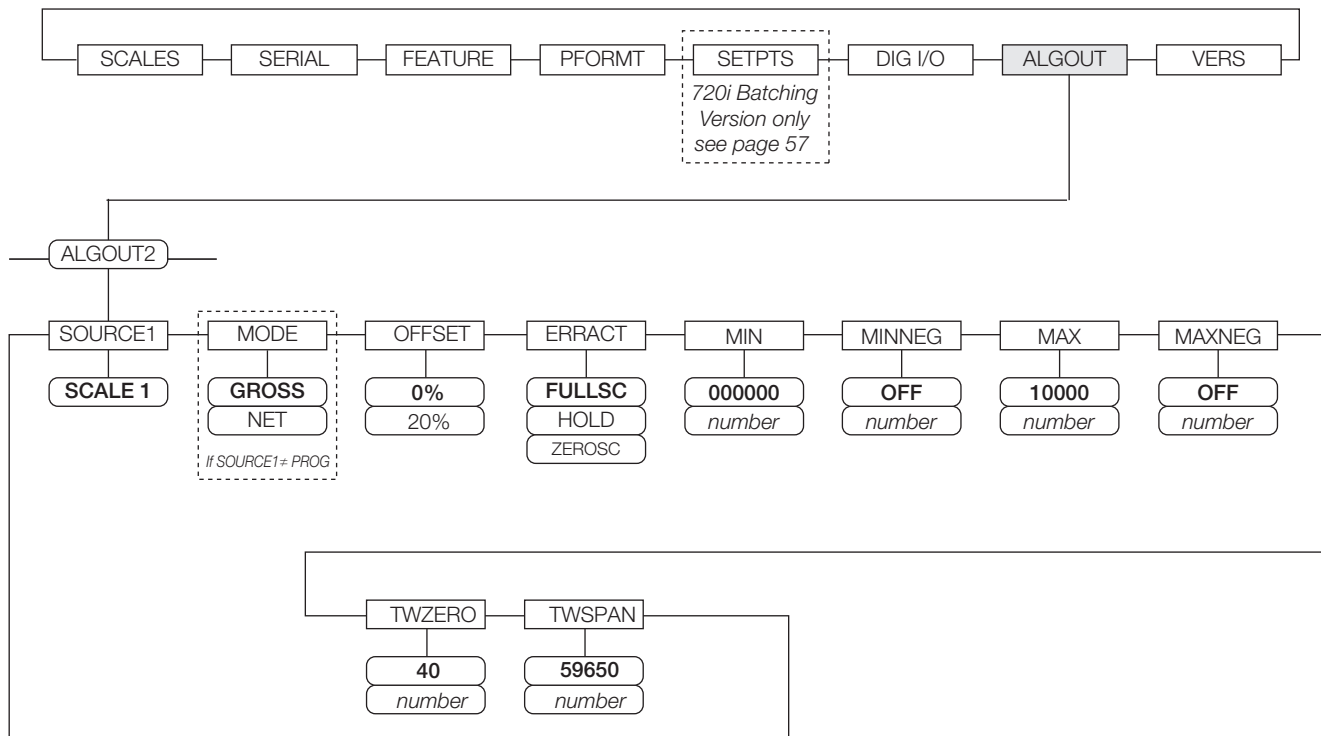

Figure 4-16. Analog Output Menu

ALGOUT Menu		
Parameter	Choices	Description
Level 2 Submenus		
SOURCE1	SCALE	Specifies the scale tracked by the analog output
MODE	GROSS NET	Specifies the weight data, gross or net, tracked by the analog output
OFFSET	0% 20%	Zero offset; Select 0% for 0–10 V or 0–20 mA output; select 20% for 4–20 mA output; This parameter must be set before calibrating the analog output
ERRACT	FULLSC HOLD ZEROSC	Error action; Specifies how the analog output responds to system error conditions; Possible values are: FULLSC: Set to full value (10 V or 20 mA) HOLD: Hold current value ZEROSC: Set to zero value (0 V or 4 mA)
MIN	000000 0–9999999	Specifies the minimum weight value tracked by the analog output; Specify a value in the range 0–9999999
MINNEG	OFF ON	Specifies the minimum negative weight value tracked by the analog output
MAX	10000 0–9999999	Specifies the maximum weight value tracked by the analog output; Specify a value in the range 0–9999999
MAXNEG	OFF ON	Specifies the maximum negative weight value tracked by the analog output
TWZERO	40 0–65535	Tweak zero; Enter tweak value to adjust the analog output zero calibration; Use a multimeter to monitor the analog output value
TWSPAN	59650 0–65535	Tweak span; Enter tweak value to adjust the analog output span calibration; Use a multimeter to monitor the analog output value

Table 4-11. Analog Output Menu Parameters

4.2.8 FLDBUS Menu

The FLDBUS menu is shown only if a DeviceNet, Profibus, EtherNet/IP, or ControlNet option card is installed.

The SWAP parameter on the FLDBUS menu enables byte swapping by the PCEE BusCommand handler rather than requiring a SWP (SWAPBYTE) instruction in the PLC.

- YES swaps bytes within the word before transmission to the scanner
- NO disables swapping

The DATASIZE parameter sets the size of the BusCommand handler data transfers. The default value (8 bytes) matches the default data size specified in the EDS and GSD files, and used by the standard discrete transfer commands. DATASIZE can be set to values from 2–128 bytes (1–64 words), but the value specified must match the data size set for the PLC Scanner I/O data size.

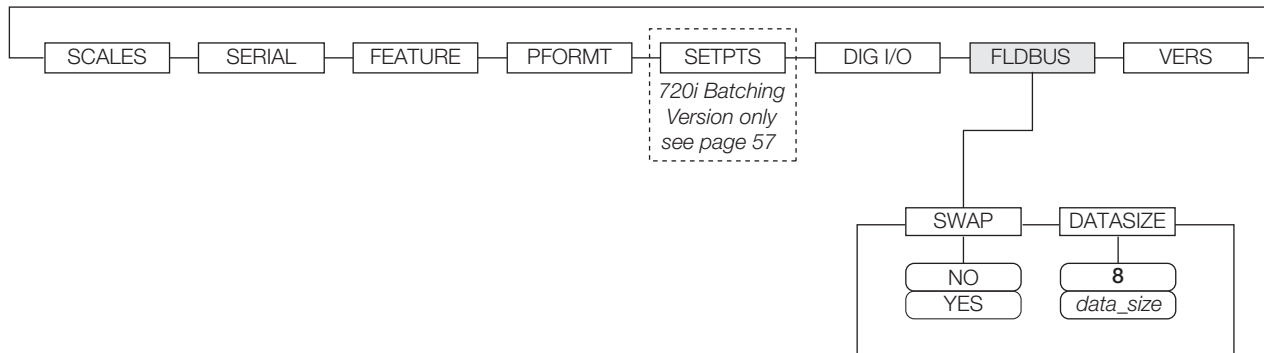

Figure 4-17. FLDBUS Menu

FLDBUS Menu		
Parameter	Choices	Description
Level 2 Submenus		
SWAP	NO YES	Specifies byte-swapping used for the fieldbus card
DATASIZE	8 2-128	Specifies the data size, in bytes, that the BusCommand handler transfers; If this parameter is set to a value other than the default (8 bytes), ensure that it matches the Scanner I/O data size specified for the PLC

Table 4-12. Fieldbus Menu Parameters

4.2.9 VERS Menu

The VERS menu can be used to check the installed software version or, by using the **RSConfig** (reset configuration) softkey, to restore all configuration parameters to their factory default values. There are no parameters associated with the Version menu: when selected, the indicator displays the installed software version number.

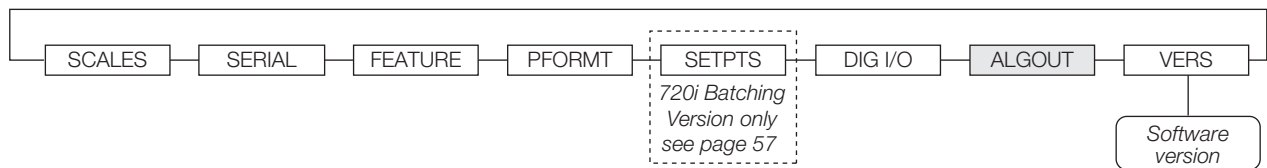

Figure 4-18. Version Menu

5.0 Calibration

This section provides an overview of 720i Programmable HMI Indicator/Controller calibration instructions.

The 720i can be calibrated using the front panel, serial commands, or Revolution[®]. Each method consists of the following steps:

- Zero calibration
- Entering the test weight value
- Span calibration
- Optional five-point linearization
- Optional rezero calibration for test weights using hooks or chains

The following sections describe the calibration procedure for each of the calibration methods.

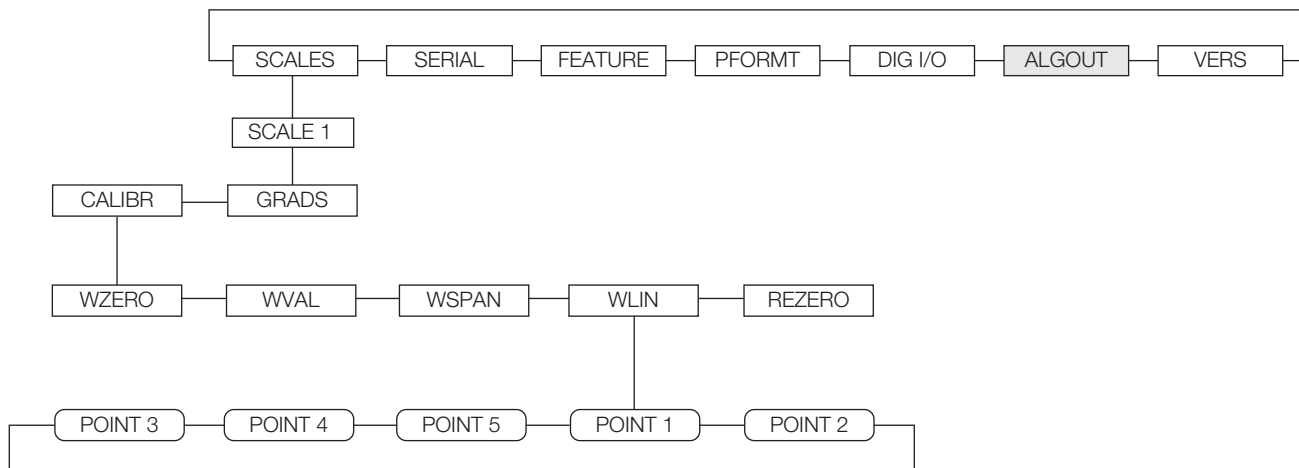

Figure 5-1. Calibration (CALIBR) Submenu

5.1 Gravity Compensation

Gravity compensation for latitude and elevation is available for the 720i. To calibrate with gravity compensation, the LOCALE parameter under the FEATURE menu must be set ON, and the LATUDE (latitude) and ELEVAT (elevation, in meters) parameters set before calibrating the indicator (Figure 4-9 on page 45).

If the indicator is later installed at a different location, gravity compensation can be applied to a pre-calibrated indicator by adjusting the LATUDE and ELEVAT parameters.

5.2 Front Panel Calibration

The CALIBR submenu (within the SCALES menu) is used to calibrate the 720i (Figure 5-2).

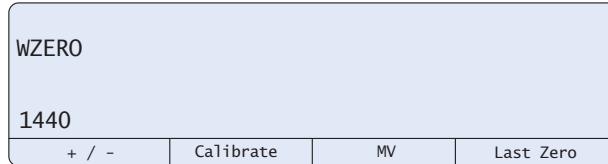

Figure 5-2. WZERO Calibration Display

The zero, span, and linear calibration point displays provide a set of softkeys used specifically for calibration procedures:

+/- – Toggles to allow entry of negative or positive values.

Last Zero – Recalls the last established zero value to allow calibration without removing tests weights or product from scale.

Calibrate – Performs calibration for the selected point

Millivolts (or **Counts**) – Toggles between display of captured A/D counts and captured millivolts values; allows entry of calibration values in mV or counts.

To calibrate the indicator using the front panel, do the following:

1. Place the indicator in setup mode (display reads **Scale Configuration**) and remove all weight from the scale platform. If test weights require hooks or chains, place the hooks or chains on the scale for zero calibration.
2. With the **SCALES** menu highlighted, press the **Down** key then select the scale to be calibrated. Press **Down** again (**GRADS** parameter highlighted) then press **Left** to highlight the **CALIBR** submenu (Figure 5-1 on page 60). Press **Down** to go to zero calibration (**WZERO**) (Figure 5-2).
3. Ensure scale is empty then press **Down** again to show the current WZERO value then press the **Calibrate** softkey to calibrate zero. When complete, the new A/D count for the zero calibration is displayed. Press **Enter** to save the zero calibration value and go to the next prompt (**WVAL**).
4. With **WVAL** displayed, press **Down** to show the stored calibration weight value. Enter the actual value of the calibration test weight using the up/down arrows or keypad then press **Enter** to save the value and go to span calibration (**WSPAN**).



NOTE: If unable to change value using keypad, use the following method to enter new value: Use the up/down keys to change the first digit to desired number then use the key pad to enter the rest of the numbers. For example, To enter 25000 change the first number using up/down arrows to 2 then use the keypad and enter 5000 so the result is 25000.

5. Place test weights on scale. Press **Down** again to show the current WSPAN value then press the **Calibrate** softkey to calibrate span. When complete, the new A/D count for the span calibration is displayed. Press **Enter** again to save the span calibration value and go to the next prompt (**WLIN**).
6. Five-point linearization (using the WLIN parameter) provides increased scale accuracy by calibrating the indicator at up to five additional points between the zero and span calibrations.

Linearization is optional: if not wanting to perform linearization, skip the WLIN parameter. If linearization values have previously been entered, these values are reset to zero during calibration. To perform linearization, follow the procedure below:

With **WLIN** displayed, Press **Down** to go to the first linearization point (**POINT 1**). Press **Down** again to show the weight value prompt (**WGT 1**) then **Down** once more to show the weight value. Place test weights on the scale then use the numeric keypad to enter the actual test weight value. Press **Enter** to save the value and move to the calibration (**CAL 1**) prompt. Press **Down** to show the current calibration value then press the **Calibrate** softkey to calibrate the linearization point. When complete, the A/D count for the linear calibration displays. Press **Enter** again to save the calibration value and go to the next prompt (**POINT 2**). Repeat for up to five linearization points. To exit the linearization parameters, press the **Up** key to return to WLIN.

7. The optional rezero function is used to remove a calibration offset when hooks or chains are used to hang the test weights.



NOTE: The rezero function cannot be used with five-point linear calibration.

- If no other apparatus was used to hang the test weights during calibration, remove the test weights and press **Up** to return to the CALIBR submenu
 - If hooks or chains were used during calibration, remove these and the test weights from the scale; With all weight removed, go to the REZERO parameter then press **Down** to show the current zero value; Press the **Calibrate** softkey to adjust the zero and span calibration values; Press **Enter** or **Up** to return to the CALIBR submenu
8. Press **Up** to return to the SCALES menu, or press the **Save and Exit** softkey to exit setup mode.

5.3 Serial Command Calibration

To calibrate the indicator using serial commands, the indicator serial port must be connected to a terminal or personal computer. See [Section 3.3.2 on page 16](#) for serial port pin assignments. See [Section 11.0 on page 100](#) for more information about using serial commands.

Once the indicator is connected to the sending device, do the following:

1. Place the indicator in setup mode (display reads **CONFIG**) and remove all weight from the scale platform. If the test weights require hooks or chains, place the hooks or chains on the scale for zero calibration.
2. Send the SC.WZERO#1 serial command to calibrate zero.
3. Place test weights on the scale and use the SC.WVAL command to enter the test weight value in the following format:

SC.WVAL#1=vvvvv<CR>

4. Send the SC.WSPAN#1 serial command to calibrate span.
5. Up to five linearization points can be calibrated between the zero and span calibration values. Use the following commands to set and calibrate a single linearization point:

SC.WLIN#1.V1=vvvvv<CR>

SC.WLIN#1.C1<CR>

The SC.WLIN#1.V1 command sets the test weight value (vvvvv) for linearization point 1. The SC.WLIN#1.C1 command calibrates the point. Repeat using the SC.WLIN#1.Vx and SC.WLIN#1.Cx commands as required for additional linearization points.

6. To remove an offset value, clear all weight from the scale, including hooks or chains used to hang test weights then send the SC.REZERO#1 serial command.
7. Send the KSAVE serial command to save the calibration changes; send KEXIT to exit setup mode.

5.4 Revolution Calibration

The Revolution Calibration Wizard provides step-by-step scale calibration. See [Section 6.0 on page 63](#) for a general overview of the Revolution utility. With the 720i connected to the PC:

1. Select **New** from the File menu.
2. The *Select Indicator* dialog box appears. Select the 720i icon and click **OK**.
3. Select **Connect** from the Communications menu.
4. Select **Scale** from the left-side menu and then click the *Scale* icon.
5. Select **Calibration Wizard** from the Tools menu and the *Calibration Wizard* window appears.
6. Select Standard Calibration (zero and span) or Standard with Multi-Point Linearization and then click **Next** to continue.
7. Enter the test weight used to calibrate the scale. If chains or hooks are used to hold the weights, check the box below the test weight value entry. This adds a Rezero step to the calibration sequence.
8. Remove all weights from the scale. If chains or hooks are used, place them on the scale. Click the **Calibrate Zero** button to perform the zero calibration. A message box appears when the process is complete.
9. Apply the test weights to the scale. Click the **Calibrate Span** button to perform the span calibration. A message box appears when the process is complete.
10. If the option for chains or hooks was selected in [Step 7](#), the Rezero step displays. Remove all weights from the scale, including chains or hooks. Click the **Re-Zero** button to calibrate the zero offset.
11. If performing a multi-point linear calibration, up to five other calibration weight values can be entered on the display. The weights must be in ascending order and must not include zero or the span weight. Enter the weight values and click the **Go** button to calibrate each point.
12. Review the new calibration values and then click **Finish** to close the Calibration Wizard or click **Cancel** to restore the previous calibration values.

6.0 Using Revolution

This section provides an overview of 720i Programmable HMI Indicator/Controller Revolution instructions.

The *Revolution* utility provides a suite of functions used to support configuration, calibration, customization, and backup of the 720i software. Hardware and software configuration, stream and ticket formatting, and database management are all supported by *Revolution*.



NOTE: The 720i uses two different versions of software depending upon the application:

- 720i Batching version software
- PCE software

Calibration values, scale configuration, database tables, and user programs, can be both saved and restored to the 720i using *Revolution*. See [Section 5.4 on page 62](#) for *Revolution* calibration procedures.

Calibration values and scale configuration can both be saved and restored to the 720i using *Revolution*.



NOTE: For system requirements visit the *Revolution* product page on [Rice Lake Weighing Systems website](#).

6.1 Connecting to the Indicator

Open the *Revolution* program and select file/new. Then select the 720i icon or the 720i Batching icon and press **OK**.

Connect the PC serial port to port 2 of the 720i then click on the **Connect** icon in the tool bar. *Revolution* attempts to establish communications to the indicator. If communications settings need to be adjusted, select **Options...** from the **Tools** menu.

Downloading to the Indicator

The **Send Configuration to Device** function in the *Revolution* Communications menu allows a *Revolution* configuration file (with or without scale calibration data) or ticket formats to be downloaded to a connected indicator in setup mode.

The **Send Section to Device** function in the *Revolution* Communications menu allows to download only the currently displayed object, such as contact information for a scale configuration.

Because less data is transferred using **Send Section to Device**, it is typically faster than a full configuration download, but there is an increased possibility that the download may fail due to dependencies on other objects. If the download fails, try performing a complete download using the **Send Configuration to Device** function.

Uploading Configuration to Revolution

The **Get Configuration from Device** function in the *Revolution* Communications menu allows the existing configuration of a connected indicator to be saved to a file on the PC. Once saved, the configuration file provides a backup that can be quickly restored to the indicator if needed. Alternatively, the file can be edited within *Revolution* and sent back to the indicator.

6.2 Installing Software Upgrades

New 720i software can be downloaded and installed using an internet connection and the Rice Lake iSeries Update Utility. The Rice Lake iSeries Update Utility is installed with the iRev application. The iRev installer can be found on the Rice Lake website. Alternatively, the update utility can be installed by itself. Navigate to <https://www.ricelake.com/software/> and download the iSeries Update Utility.



NOTE: Before upgrading to a new version of 720i system software, ensure that a copy of the current indicator configuration has been saved using Revolution. Reloading the system software requires a **RESETCONFIGURATION** function that resets all configuration and calibration values to their factory defaults.

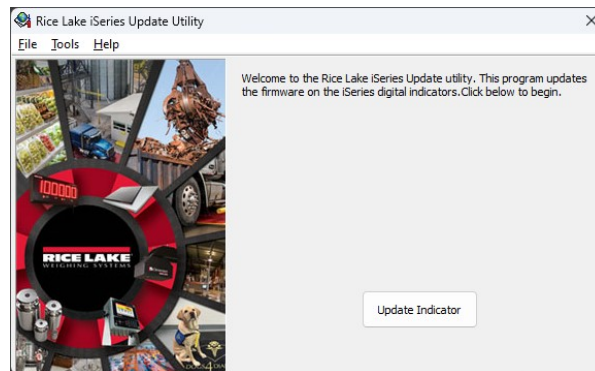

Figure 6-1. Rice Lake iSeries Update Utility

Using a web browser, navigate to the 720i product page at:

<https://www.ricelake.com/products/720i-programmable-weight-indicator-and-controller/>

Scroll down to the Firmware section to download the desired version of 720i firmware to the PC.

Once the new software is downloaded to the PC, do the following:

1. Start the Rice Lake iSerial Update Utility.
2. Disconnect power to the 720i.
3. Open the indicator enclosure and place a jumper across the SW1 boot mode pins ([Figure 3-2 on page 18](#)).
4. Connect the PC serial port to port 2 of the 720i.
5. Power on the 720i. The indicator stalls at the diagnostic monitor.
6. Select the **Update Indicator** button. A file dialog appears.
7. Navigate to the firmware file that was downloaded from the Rice Lake website.
8. Click **Open** to download the new firmware. When the download is complete, the indicator resets and goes to weigh mode.
9. Disconnect power to the indicator. Remove the jumper from the SW1 boot mode pins and place it on a single pin.
10. Power on the indicator and reload configuration as necessary.

7.0 Print Formatting

This section provides an overview of 720i Programmable HMI Indicator/Controller print formatting instructions.

The 720i provides print formats that determine the format of the printed output when the **PRINT** key is pressed, a KPRINT serial command is received, or when truck weigh-in or weigh-out operations are performed. Supported print formats are: GFMT, NFMT, ACCFMT, SPFMT, SETPNT, TRWIN, TRWOUT, ALERT, and AUXFMT1—AUXFMT20. Additionally, two header formats, HDRFMT1 and HDRFMT2, can be inserted into the other ticket formats using the <H1> and <H2> formatting commands. The particular ticket format used for a given print operation depends on the indicator configuration and the particular operation performed (Table 7-2 on page 67).

Each print format can be customized to include up to 1000 characters of information, such as company name and address, on printed tickets. Print formats may be customized using the Revolution configuration utility or serial commands.

7.1 Print Formatting Commands

Table 7-1 lists commands to format the 720i print formats. Commands included in the format strings must be enclosed between < and > delimiters. Characters outside of the delimiters are printed as text on the ticket. Text characters can include ASCII characters that can be printed by the output device.

Command	Description	Supported Ticket Formats
General Weight Data Commands		
<G>	Gross weight, current scale	GFMT, NFMT, TRWIN, TRWOUT, ACCFMT, AUXFMTxx, ALERT
<G#n>	Gross weight, scale <i>n</i>	
<N>	Net weight, current scale	
<N#n>	Net weight, scale <i>n</i>	
<T>	Tare weight, current scale	
<T#n>	Tare weight, scale <i>n</i>	
<S>	Current scale number	
<p>NOTE: Gross, net, tare, accumulator, truck and setpoint weights can be printed in configured weight units by adding the following modifiers to the gross, net and tare weight commands: /P (primary units), /D (displayed units), /S (secondary units), /T (tertiary units). If not specified, the current displayed units (/D) is assumed.</p> <p>Example: To format net weight for Scale #1 in secondary units on a ticket, use the following command: <N#3/S>.</p> <p>NOTE: Formatted weight strings contain a 10-digit weight field (including sign and decimal point, with leading zeroes suppressed), followed by a space and a two-digit units identifier. Total field length with units identifier is 12 (or 13) characters.</p>		
Accumulator Commands		
<A>	Accumulated weight, current scale	GFMT, NFMT, ACCFMT, AUXFMTxx
<A#n>	Accumulated weight, scale <i>n</i>	
<AA>	Average accumulation, current scale	
<AA#n>	Average accumulation, scale <i>n</i>	
<AC>	Number of accumulations, current scale	
<AC#n>	Number of accumulations, scale <i>n</i>	
<AT>	Time of last accumulation, current scale	
<AT#n>	Time of last accumulation, scale <i>n</i>	
<AD>	Date of last accumulation, current scale	
<AD#n>	Date of last accumulation, scale <i>n</i>	
Truck Mode Commands		
<TID>	Truck ID number	TRWIN, TRWOUT
<TR1>	Gross weight for current ticket in displayed units	
<TR2>	Tare weight for current ticket in displayed units	
<TR3>	Net weight for current ticket in displayed units	
<p>NOTE: TR1, TR2, and TR3 truck ticket weight data includes keywords INBOUND, KEYED, RECALLED, as necessary. See Section 8-3 on page 74 for Advance Truck commands.</p>		

Table 7-1. Print Format Commands

Command	Description	Supported Ticket Formats
Setpoint Commands		
<SCV>	Setpoint captured value	SPFMT
<SN>	Setpoint number	
<SNA>	Setpoint name	
<SPM>	Setpoint mode (gross or net label)	
<SPV>	Setpoint preact value	
<STV>	Setpoint target value	
Auditing Commands		
<CD>	Last calibration date	All
<NOC>	Number of calibrations	
<NOW>	Number of weighments since last calibration	
<p>NOTE: Last calibration date (<CD>) and number of calibrations (<NOC>) are updated whenever WZERO, WVAL, WSPAN, or REZERO are changed.</p> <p>Number of weighments (<NOW> command) is incremented whenever the scale weight exceeds 10% of scale capacity. Scale must return to gross or net zero before the value can be incremented again.</p>		
Formatting and General-Purpose Commands		
<nnn>	ASCII character (<i>nnn</i> = decimal value of ASCII character); Used for inserting control characters (STX, for example) in the print stream	All
<TI>	Time	
<DA>	Date	
<TD>	Time and date	
<UID>	Unit ID number (up to 8 alphanumeric characters)	
<CN>	Consecutive number (up to 7 digits)	
<H1>	Insert header format 1 (HDRFMT1) (Table 7-2 on page 67)	
<H2>	Insert header format 2 (HDRFMT2) (Table 7-2 on page 67)	
<CR>	Carriage return character	
<LF>	Line feed character	
<NLnn>	New line (<i>nn</i> = number of termination (<CR/LF> or <CR>) characters)*	
<SPnn>	Space (<i>nn</i> = number of spaces)*	
<SU>	Toggle weight data format (formatted/unformatted)	
<USnn>	Insert user print text string (from user program, SetPrintText API)	
<p>NOTE: * If <i>nn</i> is not specified, 1 is assumed. Value must be in the range 1–99.</p>		
User Program-dependent Commands		
<USnn>	Insert user print text string (from user program, SetPrintText API)	All
<EV>	Invoke user program print handler <i>x</i> (PrintFmt <i>x</i>)	AUXFMT <i>x</i>

Table 7-1. Print Format Commands (Continued)

7.2 Default Print Formats

Table 7-2 has the default print formats for the 720i and lists the conditions under which each print format is used. HDRFMT1 and HDRFMT2 formats are used to specify header information that can be used by the other ticket formats. The contents of the HDRFMTx format can be inserted into other ticket format using the <H1> and <H2> formatting commands. Use Revolution or serial commands to view and edit print formats (Section 7.3 on page 68).

Format	Default Format String	Used When
GFMT	GROSS<G><NL2><TD><NL>	Normal mode, no tare in system
NFMT	GROSS<G><NL>TARE<SP><T><NL>NET<SP2><N><NL2><TD><NL>	Normal mode, tare in system
ACCFMT	ACCUM<A><NL><DA><TI><NL>	Accumulator enabled and displayed
*SPFMT	<SCV><SP><SPM><NL>	Setpoint print operation with PSHPRNT=ON
TRWIN	<NL>ID<SP><TID><NL2>GROSS<TR1> <NL2><DA><SP><TI><NL>	Press the Weigh In softkey, enter truck ID number, and press Enter
TRWOUT	<NL6>ID<SP><TID><NL2>GROSS<TR1><NL>TARE<SP><TR2><NL>NET<SP2><TR3><NL2><DA><SP><TI><NL>	Press the Weigh Out softkey, enter truck ID number, and press Enter
TRFMT	REG ID: <TID>: <TR2> SCALE<S> <TD><NL>	Truck register currently displayed
ALERT	<COMP><NL><COAR1><NL><COAR2><NL> <CONM1><NL><COPH1><NL> <CONM2><NL><COPH2><NL> <COML><NL><ERR><NL>	—
HDRFMT1 HDRFMT2	COMPANY NAME<NL>STREET ADDRESS<NL> CITY, ST ZIP<NL2>	Must be inserted into other print format
AUXFMT.FMT#x x=1-20	GROSS<G><NL2><TD><NL> (Table 8-5 on page 75)	Formats AUX1FMT—AUX20FMT
NOTE: In OIML and CANADA modes, the letters PT (preset tare) are automatically inserted after the printed tare weight.		
* 720i Batching Version only		

Table 7-2. Default Print Formats

7.3 Customizing Print Formats

The following sections describe procedures for customizing print formats using the Revolution configuration utility or serial commands. See [Section 12.5 on page 119](#) for information about custom stream formatting.

7.3.1 Using Revolution

The Revolution configuration utility provides a ticket formatting grid with a tool bar. The grid allows ticket formatting without using the formatting commands (<NL>, <SP>, etc.) required by the front panel or serial command methods.

Type text directly into the grid using Revolution then select weight value fields from the tool bar and place them where desired.



NOTE: If using Advance Truck mode, expand all AUXFMT horizontal columns to a minimum of 80 columns due to the size of the default formats.

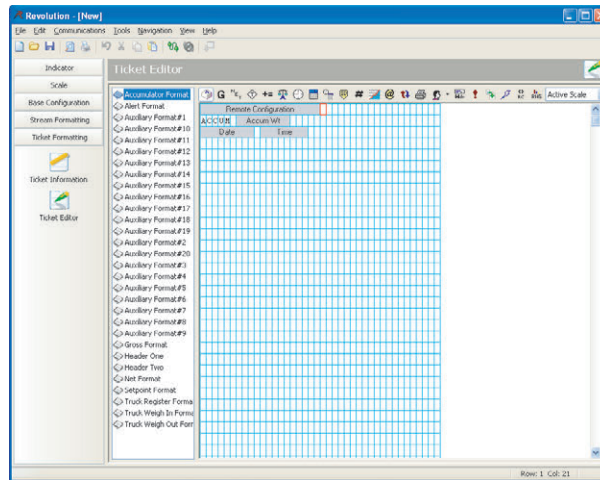

Figure 7-1. Revolution Print Formatting Display

7.3.2 Using the Front Panel

If access to equipment for communication through a serial port is not available or are working at a site where such equipment cannot be used, use the PFORMT menu to customize the print formats (Figure 7-2).

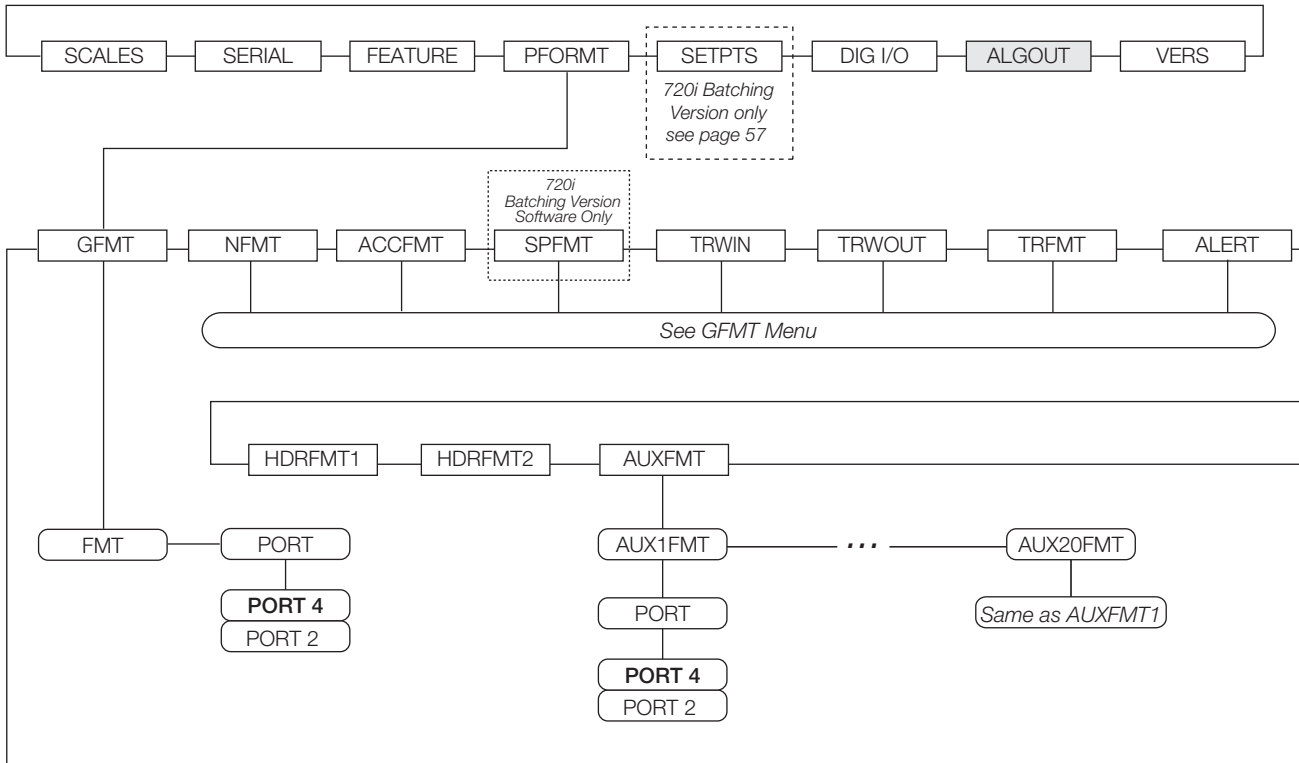
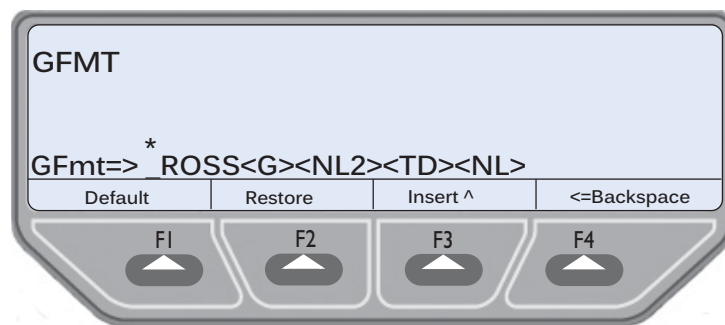

Figure 7-2. PFORMT Menu

Each print format can be edited from the front panel using a character selection (Figure 7-3). Use the navigation keys (**Up, Down, Left, Right**) to move around and between the format command line and the character selection list.



*GROSS - G is blinking to indicate active character

Figure 7-3. Print Formatting Character Selection Display

- To add a character: position the cursor in the format where to add the character; Use the **Up** key to return to the character selection list, use the navigation keys to highlight the character to add then press **Enter**; The new character is added to the left of the current cursor location in the format string
- To add a blank space to a string, position the cursor to the right of where the space is to be inserted in the format string, highlight the **SP** character in the selection list then press **Enter**
- To delete a character, position the cursor to the right of the character to be deleted from the format string then press the **CLR** key
- To add a special character, insert the < and > delimiter characters from the selection list; Use the numeric keypad to insert the decimal ASCII value (1–255) of the character between the delimiters

Example: Insert <2> to add the STX character to the print format.

To save the edited format string, position the cursor in the format string and press enter. Softkeys on the character selection display provide additional functions:

Default – Restores the string to its default value.

Home – Positions cursor at the beginning of the format string.

Cancel – Exits without saving changes to the format string.

End – Positions cursor at the end of the format string.

Restore – Restores the string to its previously saved value.

A **Print Test** softkey is under the **FMT** parameter after exiting the character selection display. If a printer is attached, this key can be used to verify the edited string format before exiting setup mode.



NOTE: The **Print Test** softkey is not available for the **HDRFMTx** formats. These formats can be output only when inserted into one of the printable ticket formats by using the **<H1>** or **<H2>** print format commands.

7.3.3 Using Serial Commands

With a personal computer, terminal or remote keyboard attached to one of the 720i serial ports, use the serial command set described in [Table 7-1 on page 65](#) to customize the print format strings.

To view the current setting of a format string, type the name of the print format and press the **Enter** key. For example, to check the current configuration of the GFMT format, type GFMT.FMT and press **Enter**. The indicator responds by sending the current configuration for the gross format:

```
GFMT.FMT=GROSS<G><NL2><TD><NL>
```

To change the format, use the GFMT.FMT or NFMT.FMT serial command followed by an equals sign (=) and the modified print format string.

To add the name and address of a company to the gross format, send the following serial command:

```
GFMT.FMT=MOE'S DUMP<NL>2356 EAST HIGHWAY ROAD<NL>SMALLTOWN<NL2><G> GROSS<NL>
```

A ticket printed using this format displays as:

```
MOE'S DUMP
2356 EAST HIGHWAY ROAD
SMALLTOWN
```

```
1345 LB GROSS
```

The ticket above could also be formatted by specifying the company address information in the HDRFMT1 ticket format then substituting the **<H1>** command for the address in the GFMT ticket format:

```
HDRFMT1=MOE'S DUMP<NL>2356 EAST HIGHWAY ROAD<NL>SMALLTOWN<NL2>
GFMT.FMT=<H1><G> GROSS<NL>
```

8.0 Truck Modes

This section provides an overview of 720i Programmable HMI Indicator/Controller truck mode instructions.

8.1 Features

The truck in/out modes are used to handle multiple truck ID numbers and weights. Truck IDs can be up to 16 alphanumeric characters in length.

Six truck modes combine stored ID, keyed tare, and value swapping features in various ways:

Mode	Stored IDs	Keyed Tares	Value Swapping
MODE1	NO	YES	YES
MODE2	NO	NO	YES
MODE3	YES	YES	YES
MODE4	YES	NO	YES
MODE5	YES	YES	NO
MODE6	YES	NO	NO
ADVANCE	See Table 8-2 on page 73		
OFF	–	–	–

Table 8-1. Truck Mode Features

Stored IDs – Keeps a database of truck IDs and weigh-in weights in the indicator’s memory. The indicator can automatically store up to 1000 truck IDs and tares; or it can clear the information after printing a weigh-out ticket. For example, if the same truck seldom crosses the scale, it may not be practical to save its ID number and weigh-in weight. However, if that same truck crosses the scale many times each day, it’s more convenient to store the information in the indicator memory and recall it when needed. Stored IDs and weights are available in modes 3, 4, 5, and 6.

Keyed Tares – Allow for manual entry of the tare weight using the numeric keypad and the **TARE** key. Keyed tares are available in modes 1, 3 and 5. To use keyed tares, an incoming truck must be empty at weigh-in, full at weigh-out.



NOTE: Some local regulations require the tare weight to be read from the scale. If so, do not use the keyed tares feature.

Value swapping – Ensures that the lower of two weight values associated with a particular ID number is used as the tare weight. For example, if a truck crosses the scale fully loaded at weigh-in then unloads and crosses the scale empty at weigh-out, the indicator automatically assigns the lesser (empty truck) weight as the tare. Value swapping is available in modes 1, 2, 3, and 4.



NOTE: In the OIML regulatory mode, modes 5 and 6 are not allowed to complete a transaction if the outbound weight is greater than the inbound weight. In this case, the indicator displays an error message "Illegal Weighment", because a negative net weight cannot be printed as a legal weight.

8.2 Using the Truck Modes

To select a truck in/out mode, enter setup mode, use the navigation keys to go to the **FEATURE** menu then to the **TRUCK** submenu to select the mode.

When a mode is selected, softkeys are automatically configured for truck mode operation (In PCEE version software only).

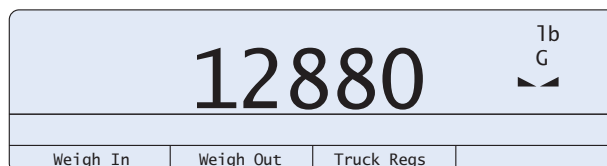

Figure 8-1. 720i Display, Truck Modes 1-6 Softkeys

8.3 Using the Truck Regs Display

The Truck Regs display by pressing the **Truck Regs** softkey in weighing mode. The display contains an alphabetical list of stored truck IDs, weigh-in weights (in primary units), and the time and date of the weigh-in transaction (Figure 8-2).

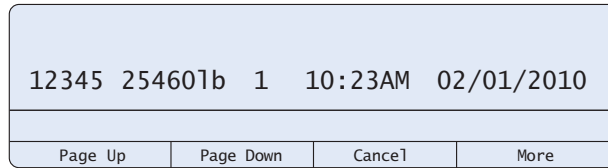

Figure 8-2. Truck Register Display, Modes 1-6

Use the **Up** and **Down** navigation keys to scroll through the truck register. Softkeys at the bottom of the Truck Regs display are described below.

Page Up – Move up ten entries in the truck register.

Page Down – Move down ten entries in the truck register.

Cancel – Exits to weighing mode.

More – The second (or first) page of truck register softkeys.

Delete – Deletes the highlighted truck ID from the truck register.

Delete All – Deletes all truck IDs from the truck register.

The truck register can be printed to an attached printer by pressing the **Print** key while the Truck Regs displays. The printed register uses the TRFMT print format (Section 7.2 on page 67).

8.4 Weigh-In Procedure

In modes 1 and 2, the indicator erases truck ID numbers and tare weights from memory after the transaction. In modes 3–6, the truck ID and weigh-in weight values are saved after the weigh-out ticket has been processed.

The general weigh-in procedure is as follows:

1. The empty truck moves onto the scale for weigh-in.
2. Press the **Weigh In** softkey.
3. A prompt displays to enter the truck ID (up to eight alphanumeric characters). Enter the ID then press the **Enter** key.
4. Any additional prompts turned on in Advance Mode prompts the operator to enter the required information in order to proceed to the next step (“Advance Mode Weigh-In Procedure” on page 76).
5. Indicator generates the weigh-in ticket:

```
ID 304812
GROSS 15000. LB INBOUND
01/14/2010 10:24 AM
```
6. Truck leaves the scale.

8.5 Weigh-Out Procedure

The general weigh-out procedure is as follows:

1. The loaded truck moves onto the scale for weigh-out.
2. If truck ID is known, press the **Weigh Out** softkey, enter the ID, and press the **Enter** key.
If ID is not known, press the **Truck Regs** softkey to view list of stored IDs (Figure 8-2). Scroll to the correct truck ID, note the ID number then press the **Cancel** softkey to return to the weight display. From the weight display, press **Weigh Out**, key in the ID then press the **Enter** key.
3. Any additional prompts turned on in Advance Mode prompts the operator to enter the required information in order to proceed to the next step (“Advance Mode Weigh-In Procedure” on page 76).
4. Indicator generates the weigh-out ticket. In modes 1 and 2, the ID is deleted once the weigh-out ticket is processed.

8.6 Single-Transaction Tare Weights and IDs

One-time transactions are supported in all modes that can be configured to use stored IDs (modes 3–6). This function allows one-time weighing of trucks without adding the truck ID and weigh-in weight to the permanent truck register.

To use this function, press the **Weigh In** or **Weigh Out** softkey then enter a truck ID containing a decimal point. IDs entered with a decimal point as part of the ID are erased from the truck register when the transaction is complete.



NOTE: This option is not available with Advance Mode enabled.

8.7 Using the Advance Mode

Under the TRUCK submenu ADVANCE is available. Setting the truck mode to this enables the advance mode.

This automatically turns on the **Weigh, Reports** and **Management** softkeys.



NOTE: If using Revolution to enable Advanced Mode, set the **Weigh, Reports** and **Management** softkeys.

For a complete description for each setting of the following choices, see Advance Mode in [Table 4-8 on page 51](#).

Mode	Description
VEHICLE	Vehicle ID and Description
MATERIAL	Material ID, Name and Description
CUSTOMER	Customer ID, Name and Description
SOURCE	Source ID, Name and Description
DELIVERY	Delivery Number
DELIVERY WGT	Weight of the material
REMARKS	Additional comments
PRINT	Configuration for the Weigh-In ticket
REPRINT	Configuration for reprinting the Weigh-In and Weigh-Out tickets
SHIFTS	Configure the shift start and end times, reports use these values
DAY	Configure day start and end times, reports use this value
SERIAL NUMBER (Ticket Serial #)	0–9999999; Default: 0

Table 8-2. Advance Mode Features



NOTE: Advanced Truck Mode only stores transactions in the primary units of measure.

In Advance Mode the **Weigh, Reports** and **Management** softkeys are enabled. Softkeys are described below.



Figure 8-3. 720i Display, Advance Mode Softkeys

Weigh – Start the Weigh-In and Weigh-Out Procedure ([“Advance Mode Weigh-In Procedure” on page 76](#)).

Reports – Select which report to print. There are four sub menus under the **Reports** softkey: **Summary, Daily, Detail, and Code List**.

Management – Add and remove materials, customers, and source IDs and names.

While in a submenu the **Tare** key can be pressed to go back to the previous menu.

On Weigh-In the AUX1FMT is printed.

On Weight-Out the AUX2FMT is printed.

When printing Shift/Day and Detail All/Pending reports:

- AUX3FMT is the header
- AUX4FMT is each line for each transaction
- AUX5FMT is the footer/total lines

When printing Summary Reports:

- AUX6FMT is the header
- AUX7FMT is the header for Source Reports
- AUX8FMT is the header for Customer Reports
- AUX9FMT is the header for Material Reports
- AUX10FMT is each line for each transaction for Source Reports
- AUX11FMT is each line for each transaction for Customer Reports
- AUX12FMT is each line for each transaction for Material Reports
- AUX13FMT is the sub total line
- AUX14FMT is the footer/total lines

When printing the Code list reports:

- AUX15FMT is the header
- AUX16FMT is printed for the Source
- AUX17FMT is printed for the Customers
- AUX18FMT is printed for the Materials

Print Format Commands

When the ADVANCE mode is selected the AUX formats are changed to generic in/out formatting. This can be changed using an EDP command ([Section 11.1.9 on page 112](#)).

To see the configuration of the AUX format send:

AUXFMT.FMT#*n* (where *n* is the aux format number)

To change the format serially send:

AUXFMT.FMT#*n*=<><><><CR>

Command	Description	Characters
<TID>	Truck ID	12 alpha numeric
<MID>	Material ID	10 numeric only, no decimals
<MN>	Material Name / Description	30 alpha numeric
<CID>	Customer ID	10 numeric only, no decimals
<CSN>	Customer Name / Description	30 alpha numeric
<SID>	Source ID	10 numeric only, no decimals
<SD>	Source Name / Description	30 alpha numeric
<DN>	Delivery / Challan Number	15 alpha numeric
<DW>	Delivery / Challan Weight	Floating Point 9 Characters
<TC>	Remarks / Comments	30 alpha numeric
<VD>	Vehicle ID / Description	10 alpha numeric
<TDO>	Time / Date Out	18
<TDI>	Time / Date in	18
<RT>	Report Type	24
<JN>	Julian Date Number	Floating Point with 5 Decimal Places
<TCN>	Ticket Consecutive Number / Serial Number	Numeric

Table 8-3. Print Format Commands

Command	Description
<RTT>	Report Total Tare
<RTN>	Report Total Net
<RSD>	Report Start Date (used for summary reports)
<RED>	Report End Date (used for summary reports)
<SBG>	Subtotal Gross
<SBN>	Subtotal Net
<SBT>	Subtotal Tare

Table 8-4. Print Format Commands

Advance Mode Default Print Formats

See [Table 8-5](#) for the default print formats for ADVANCE mode. By default, all print formats are set to port 4.

Use Revolution or serial commands to view and edit print formats ([Section 7.3 on page 68](#)).

 **IMPORTANT:** The AUXFMTs are automatically set up when Advanced Truck Mode is selected. To revert back to default the unit must be reset using the RESETCONFIGURATION function. See [Section 11.1.3 on page 101](#) for help using RESETCONFIGURATION. If Revolution is used then the file also has the AUXFMTs set for Advance Truck formats; prior to downloading conduct a review on additional files.

Format	Default Format String
AUXFMT.FMT#1	<NL><H1><NL>ID<SP14>: <TID><NL>SERIAL NUMBER: <TCN><NL>INBOUND WEIGHT: <TR1><NL>IN<SP14>: <TDI><NL>
AUXFMT.FMT#2	<NL><H1><NL>ID<SP14>: <TID><NL>SERIAL NUMBER: <TCN><NL>TRUCK TYPE<SP6>: <VD><NL>DELIVERY NUMBER: <DN><NL>DELIVERY WGT.: <DW><NL>CUSTOMER<SP8>: <CID> <CSN><NL>SOURCE<SP10>: <SID> <SD><NL>MATERIAL<SP8>: <MID> <MN><NL>GROSS<SP11>: <TR1><NL>TARE<SP12>: <TR2><NL>NET<SP13>: <TR3><NL>IN<SP14>: <TDI><NL>OUT<SP13>: <TDO><NL>COMMENTS<SP8>: <TC><NL>
AUXFMT.FMT#3	<NL><H1><NL><RT> PRINTING TIME & DATE: <TD><NL> <NL>VEHICLE NO. VEHICLE TYPE MATE- RIAL<SP9>PLACE<SP6>GROSS WT. TIME & DATE<NL> <SP7>IN<NL>SERIAL NO. DELIVERY NO. PARTY<SP12>DELIVERY WGT<SP15>OUT<NL> <NL>
AUXFMT.FMT#4	<TID> <VD> <MID><MN><TR1> <TDI> <TR3> <NL><TCN><SP14><TR2> <TDO><NL>
AUXFMT.FMT#5	<NL> <NL><SP43><RTG><SP13><RTN><NL><SP43><RTT><NL> <NL>~ - GROSS WEIGHING FIRST<NL>
AUXFMT.FMT#6	<H1><NL><RT> FOR THE PERIOD : <RSD> TO <RED><NL>PRINTING TIME & DATE : <TD><NL> <NL>
AUXFMT.FMT#7	SL. SOURCE ID<SP9>MATERIAL ID VEHICLE NUMBER WEIGHING NET WEIGHT<NL>NO. SOURCE NAME<SP7>MATERIAL NAME DATE & TIME (KG)<NL><SP40>CHALLAN NUMBER<NL> <NL>
AUXFMT.FMT#8	SL. CUSTOMER ID<SP7>MATERIAL ID VEHICLE NUMBER WEIGHING NET WEIGHT<NL>NO. CUSTOMER NAME MATERIAL NAME DATE & TIME (KG)<NL><SP40>CHALLAN NUMBER<NL> <NL>
AUXFMT.FMT#9	SL. MATERIAL ID<SP8>CUSTOMER ID VEHICLE NUMBER WEIGHING NET WEIGHT<NL>NO. MATERIAL NAME<SP6>CUSTOMER NAME DATE & TIME (KG)<NL><SP40>CHALLAN NUMBER<NL>
AUXFMT.FMT#10	<TCN> <SID><SP10><MID><SP10><TID> <TD> <TR3><NL><SP7><SD><SP11><MN><SP11><DN><NL>
AUXFMT.FMT#11	<TCN> <CID><SP10><MID><SP10><TID> <TD> <TR3><NL><SP7><CSN><SP10><MN><SP11><DN><NL>
AUXFMT.FMT#12	<TCN> <MID><SP10><CID><SP10><TID> <TD> <TR3><NL><SP7><MN><SP11><CSN><SP10><DN><NL>
AUXFMT.FMT#13	<NL><SP58> <NL><SP60><SBN><NL>
AUXFMT.FMT#14	<NL> <NL><SP62><RTN><NL> <NL>~ - GROSS WEIGHING FIRST<NL>
AUXFMT.FMT#15	<TD><NL><RT><NL> <NL> ID NAME<NL>
AUXFMT.FMT#16	<SID><SP4><SD><NL>
AUXFMT.FMT#17	<CID><SP4><CSN><NL>
AUXFMT.FMT#18	<MID><SP4><MN><NL>
AUXFMT.FMT#19	GROSS<G><NL2><TD><NL>
AUXFMT.FMT#20	GROSS<G><NL2><TD><NL>

Table 8-5. Default Print Formats for Advanced Truck

 **NOTE:** If Advance Mode features are turned off, the field should be removed from the Print Format, otherwise a blank field is printed ([Table 8-3 on page 74](#)).

Advance Mode Weigh-In Procedure

The Advance Mode weigh-in procedure is as follows:

1. The truck moves onto the scale for weigh-in.
2. Press the **Weigh** softkey.
3. A prompt to enter the truck ID (up to 12 alphanumeric characters) displays. Enter the ID then press the **Enter** key.
4. A prompt to enter Vehicle, Material, Customer, Source, Delivery, Delivery Wgt, and Remarks (comments) if enabled displays.
Each of these may be set to ON (prompt) or OFF in Advance Mode. The default is ON.
5. Indicator generates the weigh-in ticket.
6. Truck leaves the scale.

Advance Mode Weigh-Out Procedure

The Advance Mode weigh-out procedure is as follows:

1. The truck moves onto the scale for weigh-out.
2. Press the **Weigh** softkey, enter the ID, and press the **Enter** key.
3. Indicator generates the weigh-out ticket.



NOTE: *The truck may be empty or loaded for either of the above procedures. The 720i calculates the proper net weight.*

Advance Mode Keyed Tare

If the truck tare weight is known, Advance Mode keyed tare allows for both weigh-in and weigh-out to be performed in one transaction.

1. Manually enter the tare weight using the numeric keypad.
2. Press the **TARE** key.
3. Press the **Weigh** softkey, enter the truck ID, and press the **Enter** key.
4. Indicator generates the weigh-out ticket.



NOTE: *Some local regulations require the tare weight to be read from the scale. Do not use the keyed tares feature.*

8.7.1 Advance Mode Menus

Advance Mode Reports Menu

In Advance Mode the Weigh, **Reports** and **Management** softkeys are enabled. The **Reports** softkey is described below.



NOTE: While in a submenu the Tare key can be pressed to go back to the previous menu.

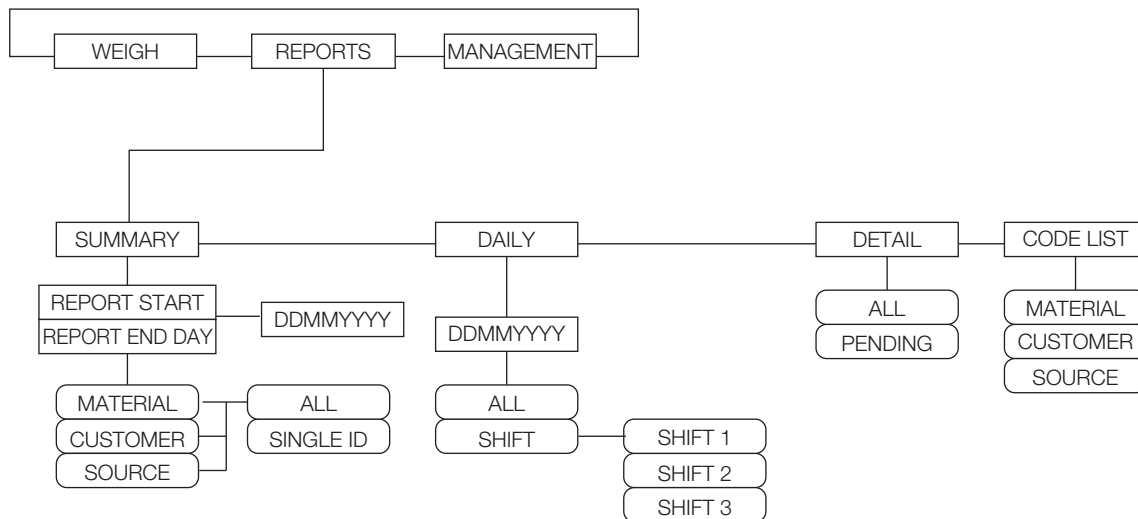

Figure 8-4. Reports Menu

Print Menu		
Parameter	Choices	Description
Level 2 Submenus		
SUMMARY	REPORT START REPORT END DAY	Report from beginning date to ending date specified by the operator (DDMMYYYY) Report by material, customer or source
DAILY	REPORT DAY	Report of selected date entered by operator, can be all transactions or by a selected shift (1, 2 or 3)
DETAIL	ALL PENDING	All transactions in the database or pending transactions only
CODE LIST	MATERIAL CUSTOMER SOURCE	List of stored items by material, customer or source
Level 3 Submenus		
MATERIAL	ALL SINGLE ID	Specifies the material for the Summary Report
CUSTOMER	ALL SINGLE ID	Specifies the customer for the Summary Report
SOURCE	ALL SINGLE ID	Specifies the source of the Summary Report
ALL	-	Prints all shifts for the Daily Report
SHIFT	SHIFT 1 SHIFT 2 SHIFT 3	Prints select shifts for the Daily Report

Table 8-6. Reports Menu Parameters

Advance Mode Management Menu

In Advance Mode the **Weigh**, **Reports** and **Management** softkeys are enabled. The **Management** softkey is described below.



NOTE: While in a submenu the **TARE** key can be pressed to go back to the previous menu.

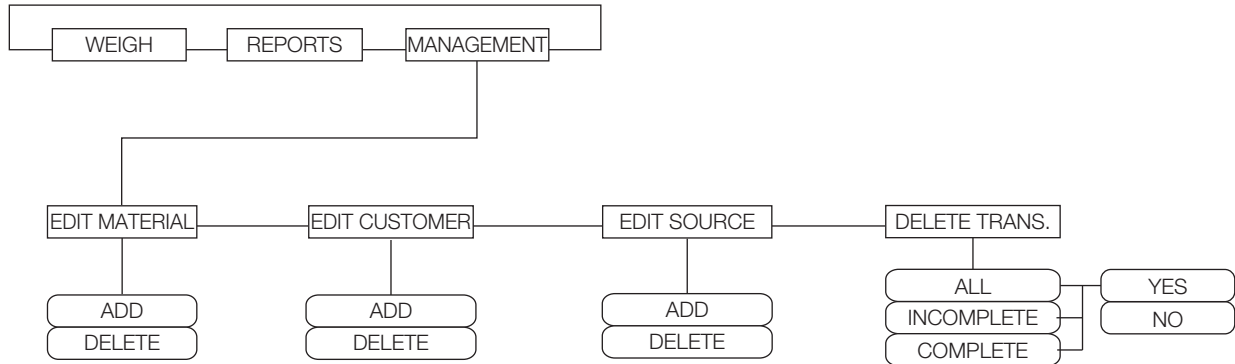

Figure 8-5. Management Menu

Management Menu		
Parameter	Choices	Description
Level 2 Submenus		
EDIT MATERIAL	ADD DELETE	Add or delete material
EDIT CUSTOMER	ADD DELETE	Add or delete customers NOTE: The system can store a total 99 customers, files and source numbers. These records must be keyed in as there is no file upload or download available.
EDIT SOURCE	ADD DELETE	Add or delete source
DELETE TRANS.	ALL INCOMPLETE COMPLETE	Specifies which transactions to delete; The system offers a Yes or No to confirm prompt before the transactions are deleted; The system can store 1496 transactions NOTE: It is required to manually delete the transactions when the system is full.

Table 8-7. Management Menu Parameters

9.0 Setpoints

This section provides an overview of 720i batch version software used for setpoint control.



NOTE: Operations in this chapter require the 720i batching version of software (720i batching).

The 720i indicator provides 32 configurable setpoints for control of both indicator and external equipment functions. Setpoints can be configured to perform actions or functions based on specified parameter conditions. Parameters associated with various setpoint kinds can, for example, be configured to perform functions (print, tare, accumulate), to change the state of a digital output controlling indicator or external equipment functions, or to make conditional decisions.



NOTE: Weight-based setpoints are tripped by values specified in primary units only.

9.1 Batch and Continuous Setpoints

720i setpoints can be either continuous or batch setpoints.

Continuous setpoints – are free-running: the indicator constantly monitors the condition of free-running setpoints at each A/D update. The specified setpoint action or function is performed when the designated setpoint parameter conditions are met. A digital output or function assigned to a free-running setpoint continuously changes state, becoming active or inactive, as defined by the setpoint parameters.

Batch setpoints – are active one at a time, in an ordered sequence. The 720i can use setpoints to control up to 32 separate batch processing steps.

A digital output associated with a batch setpoint is active until the setpoint condition is met then latched for the remainder of the batch sequence.

To use batch setpoints, activate the BATCHNG parameter on the SETPTS menu. This parameter defines whether a batch sequence is automatic or manual. AUTO sequences repeat continuously, while MANUAL sequences require a BATSTRT signal. The BATSTRT signal can be initiated by a digital input, serial command, or **Batch Start** softkey.

For setpoint kinds that can be used as either continuous or batch setpoints, the BATCH parameter must also be set ON (setpoint kinds that can only be used as batch setpoints do not require the BATCH parameter). If the setpoint is defined but the BATCH parameter is off, the setpoint operates as a continuous setpoint, even during batch sequences.



NOTE: In applications that contain both batch setpoint routines and continuous setpoints, continuous setpoints should be kept separate from the batch sequence. This is especially true when using CONCUR or TIMER setpoints to perform actions or functions based on the batch sequence. CONCUR and TIMER setpoints should not be included in the referenced START and END setpoint sequence.

Kind	Description	Batch	Continuous
OFF	Setpoint turned off/ignored	--	--
GROSS	Gross setpoint; Performs functions based on the gross weight; The target weight entered is considered a positive gross weight	X	X
NET	Net setpoint; Performs functions based on the net weight; The target weight entered is considered a positive net weight value	X	X
-GROSS	Negative gross weight; Performs functions based on the gross weight; The target weight entered is considered a negative gross weight	X	X
-NET	Negative net weight; Performs functions based on the net weight; The target weight entered is considered a negative net weight value	X	X
ACCUM	Accumulate setpoint; Compares the value of the setpoint to the source scale accumulator; The accumulator setpoint is satisfied when the value of the source scale accumulator meets the value and conditions of the accumulator setpoint	X	X
ROC	Rate-of-change setpoint; Performs functions based on the rate-of-change (ROC) value	X	X
+REL	Positive relative setpoint; Performs functions based on a specified value above a referenced setpoint, using the same weight mode as the referenced setpoint	X	X
-REL	Negative relative setpoint; Performs functions based on a specified value below a referenced setpoint, using the same weight mode as the referenced setpoint	X	X

Table 9-1. Setpoint Kinds

Kind	Description	Batch	Continuous
%REL	Percent relative setpoint; Performs functions based on a specified percentage of the target value of a referenced setpoint, using the same weight mode as the referenced setpoint; The actual target value of the %REL setpoint is calculated as a percentage of the target value of the referenced setpoint	X	X
RESREL	Relative to a result setpoint; Performs functions based on a specified percentage of the captured value of a referenced setpoint, using the same weight mode as the referenced setpoint; The actual target value of the RESREL setpoint is calculated as a percentage of the captured value of the referenced setpoint, rather than the target value	X	X
PAUSE	Pauses the batch sequence indefinitely; A BATSTRT signal must be initiated to continue the batch process	X	--
DELAY	Delays the batch sequence for a specified time; The length of the delay (in tenths of a second) is specified on the VALUE parameter	X	--
WAITSS	Wait for standstill; Suspends the batch sequence until the scale is at standstill	X	--
COUNTER	Specifies the number of consecutive batch sequences to perform; Counter setpoints should be placed at the beginning of a batch routine	X	--
AUTOJOG	Automatically checks the previous weight-based setpoint to verify the setpoint weight value is satisfied in a standstill condition; If the previous setpoint is not satisfied when at standstill, the AUTOJOG setpoint activates the digital output of the previous weight-based setpoint for a period of time, specified on the VALUE parameter; The autojog process repeats until the previous weight-based setpoint is satisfied when the scale is at standstill NOTE: The AUTOJOG digital output is typically used to signify that an autojog operation is being performed. AUTOJOG should not be assigned to the same digital output as the related weight-based setpoint.	X	--
COZ	Center of zero; Monitors for a gross zero condition; The digital output associated with this setpoint kind is activated when the referenced scale is a center of zero; No value is required for this setpoint	--	X
INMOTON	In motion; Monitors for an in-motion condition; The digital output associated with this setpoint is activated when the scale is not at standstill; No value is required for this setpoint	--	X
INRANGE	In range; Monitors for an in-range condition; The digital output associated with this setpoint is activated when the scale is within capacity range; No value is required for this setpoint	--	X
BATCHPR	Batch processing signal; The digital output associated with this setpoint is activated whenever a batch sequence is in progress; No value is required for this setpoint	--	X
TIMER	Tracks the progress of a batch sequence based on a timer; The timer value, specified in tenths of a second on the VALUE parameter, determines the length of time allowed between start and end setpoints; The indicator START and END parameters are used to specify the start and end setpoints; If the END setpoint is not reached before the timer expires, the digital output associated with this setpoint is activated	--	X
CONCUR	The digital output assigned to the Concur Setpoint should not be used by another Concur Setpoint, as this may cause a conflict in setting the output state; Two types of concur setpoints can be configured: Type 1 (VALUE=0): The digital output associated with this setpoint becomes active when the START setpoint becomes the current batch step and remains active until the END setpoint becomes the current batch step Type 2 (VALUE > 0): If a non-zero value is specified for the VALUE parameter, that value represents the timer, in tenths of a second, for this setpoint; The digital output associated with this setpoint becomes active when the START setpoint becomes the current batch step and remains active until the timer expires	--	X
TOD	Time of day setpoint; Performs functions when the internal clock time of the indicator matches the specified setpoint time	X	X
DELTA	Delta weight setpoint; Satisfied when the change in weight on the scale is equal to or exceeds the absolute value specified for the setpoint	X	--
CHKWEI	Checkweigher setpoint; Allows specification of over- and under-weight values; Up to three digital outputs can be configured to represent overweight, underweight, and accept conditions	--	X
ALWAYS	Always setpoint; This setpoint is always satisfied; It is typically used to provide an endpoint for true/false branching batch routines	X	--
NEVER	Never setpoint; This setpoint is never satisfied; Used to branch to a designated setpoint in true/false branching batch routines which the batch does not continue through the normal sequence of batch setpoints	X	--

Table 9-1. Setpoint Kinds (Continued)

9.2 Setpoint Menu Parameters

See [Figure 9-1](#) for the general structure of the SETPTS menu. Submenus (indicated by Go to X in [Figure 9-1](#)) for various groups of setpoint kinds are on the following pages ([Figure 9-3 on page 83](#) through [Figure 9-9 on page 91](#)); parameter descriptions for the submenus are provided in [Table 9-2 on page 88](#).

See [Table 9-1 on page 79](#) for descriptions of each of the setpoint kinds.

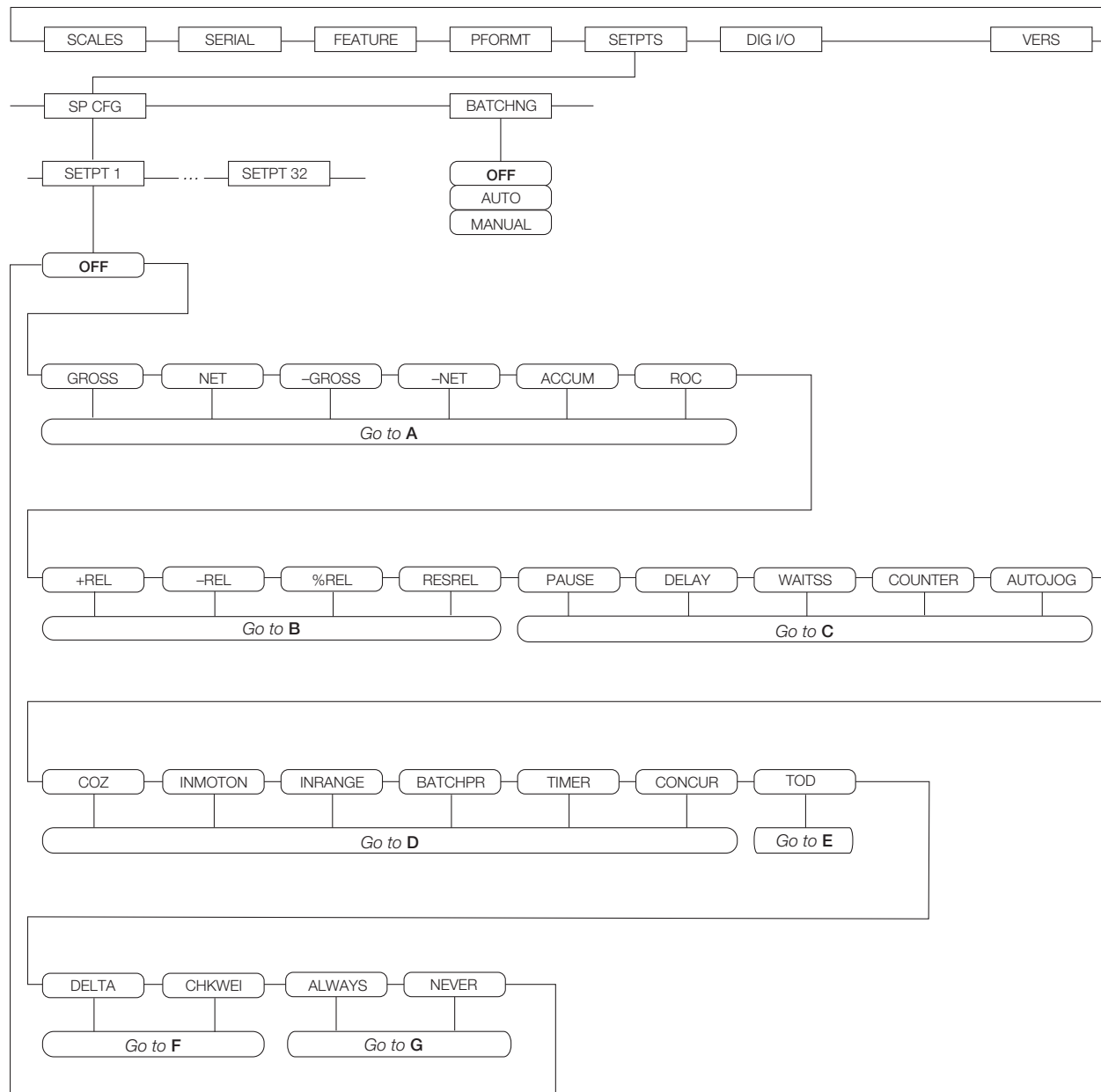

Figure 9-1. SETPTS Menu

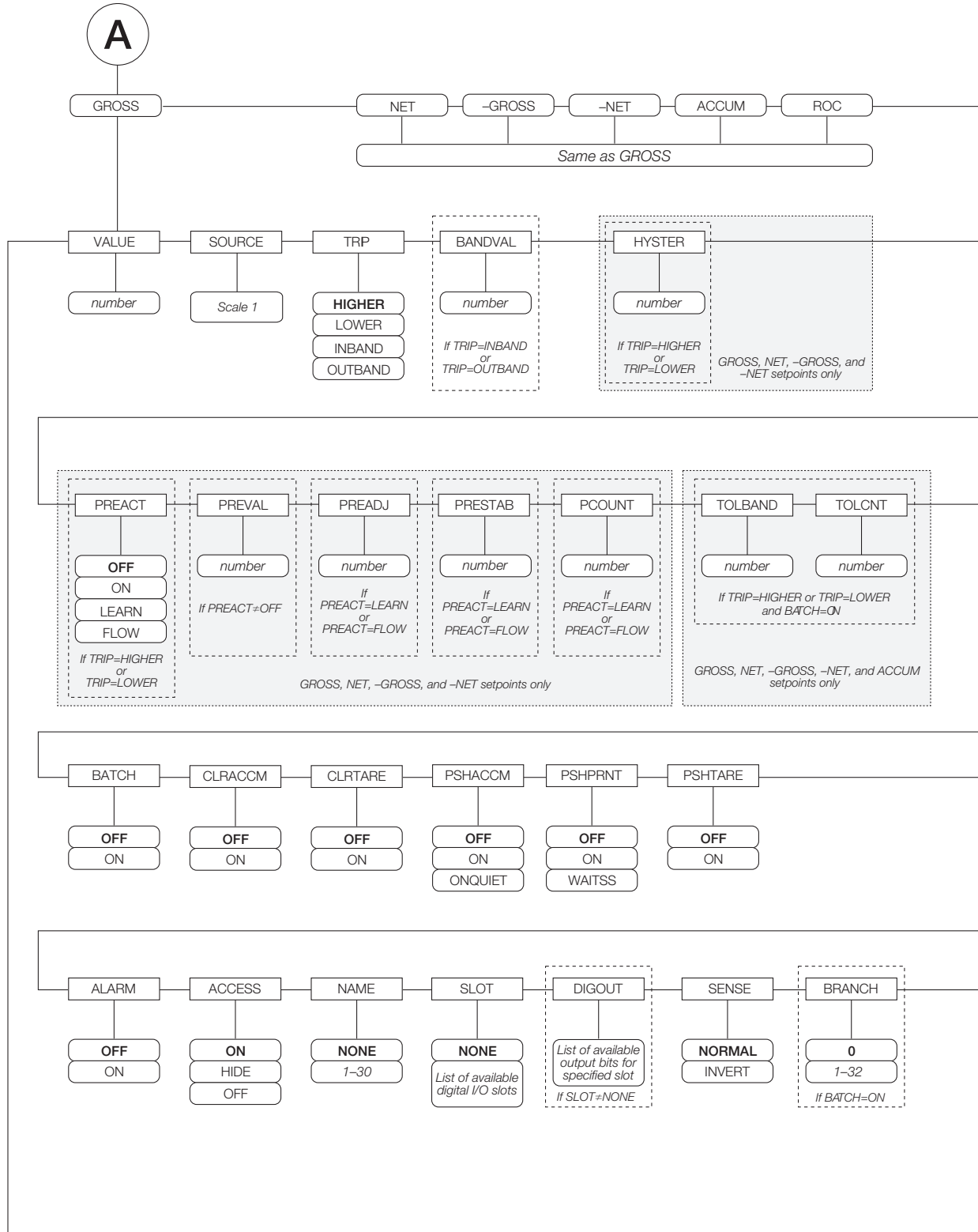

Figure 9-2. GROSS, NET, -GROSS, -NET, ACCUM, and ROC Setpoint Parameters

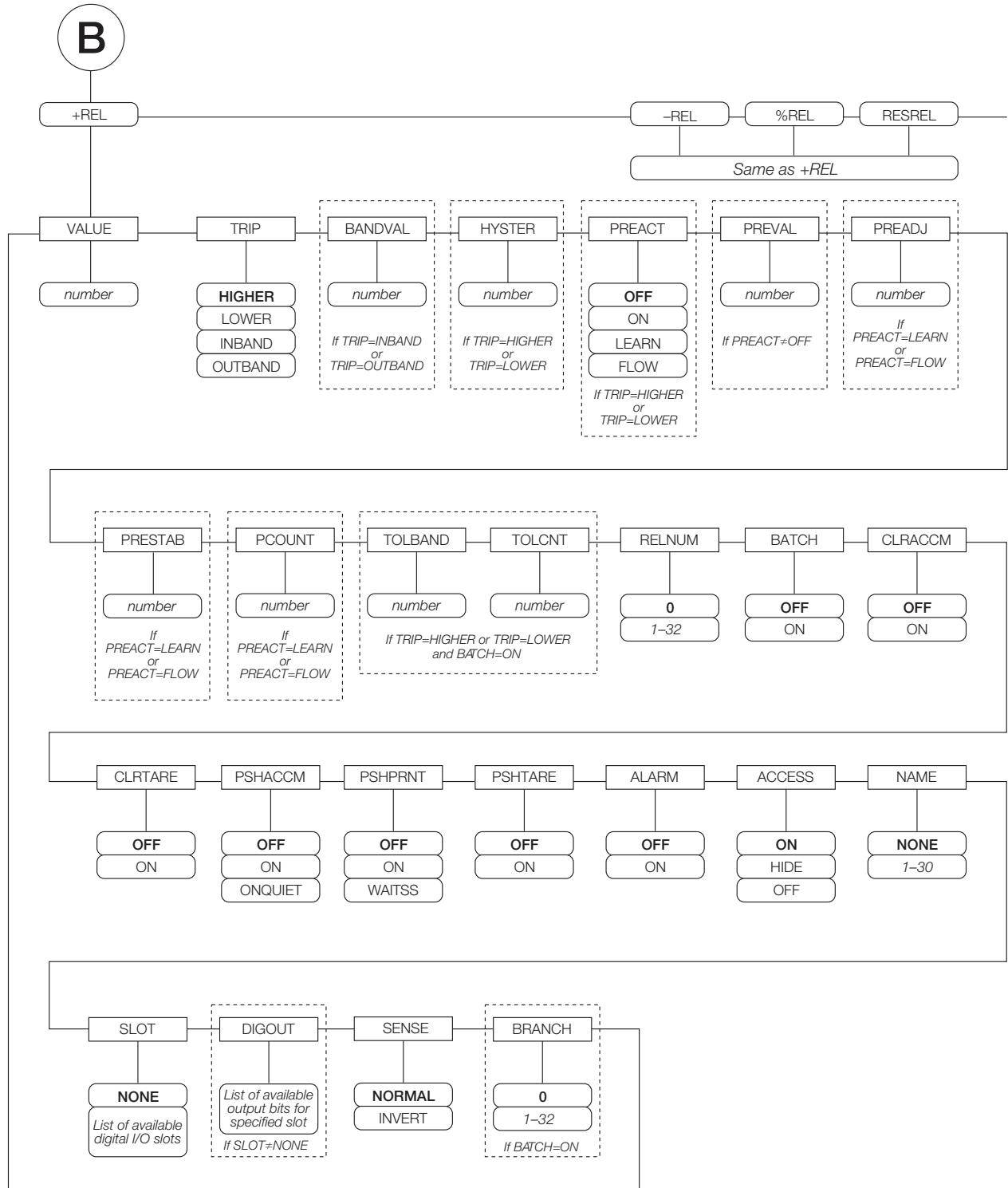

Figure 9-3. +REL, -REL, %RELS and RESREL Setpoint Parameters

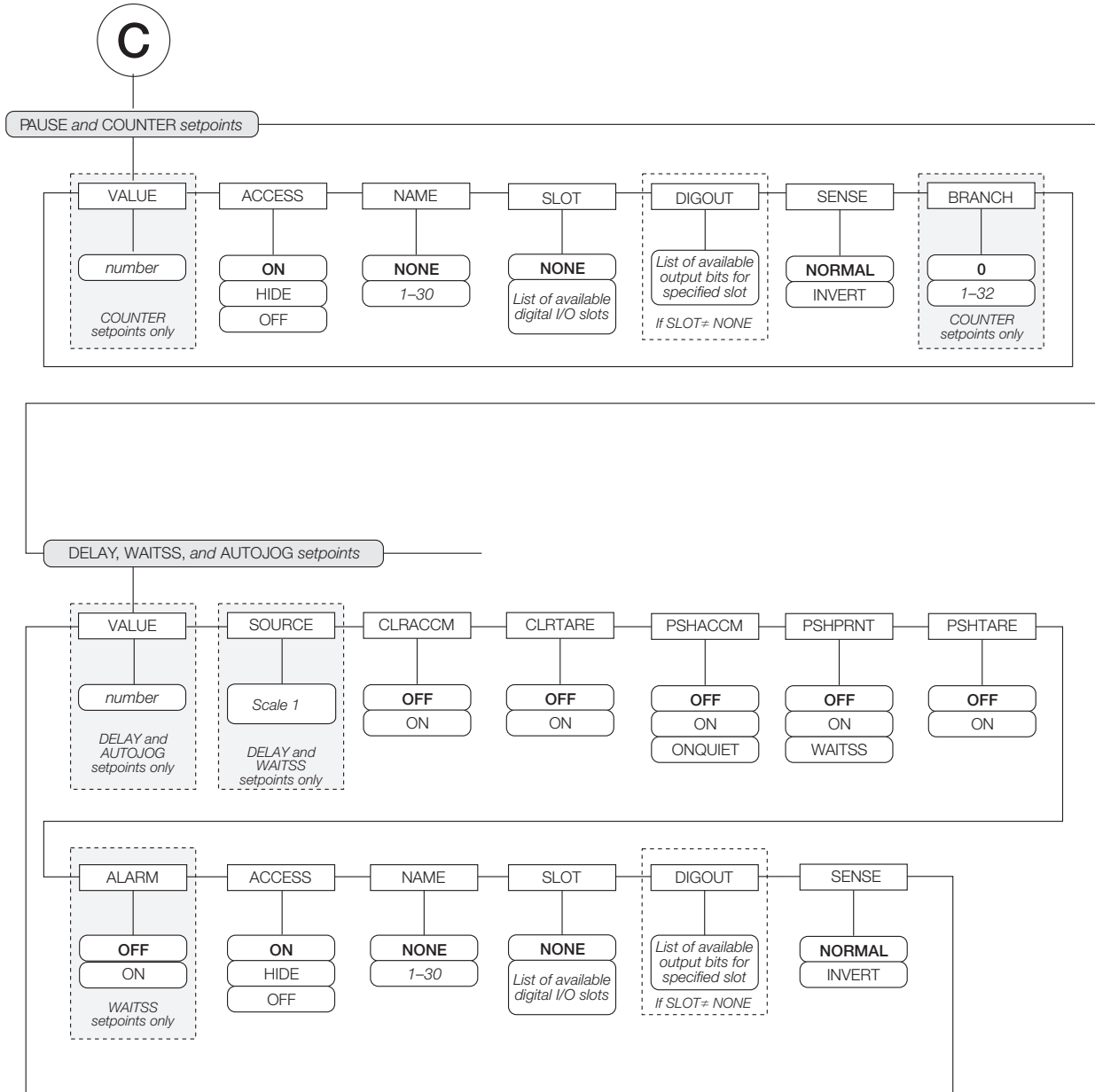

Figure 9-4. PAUSE, COUNTER, DELAY, WAITSS, and AUTOJOG Setpoint Parameters

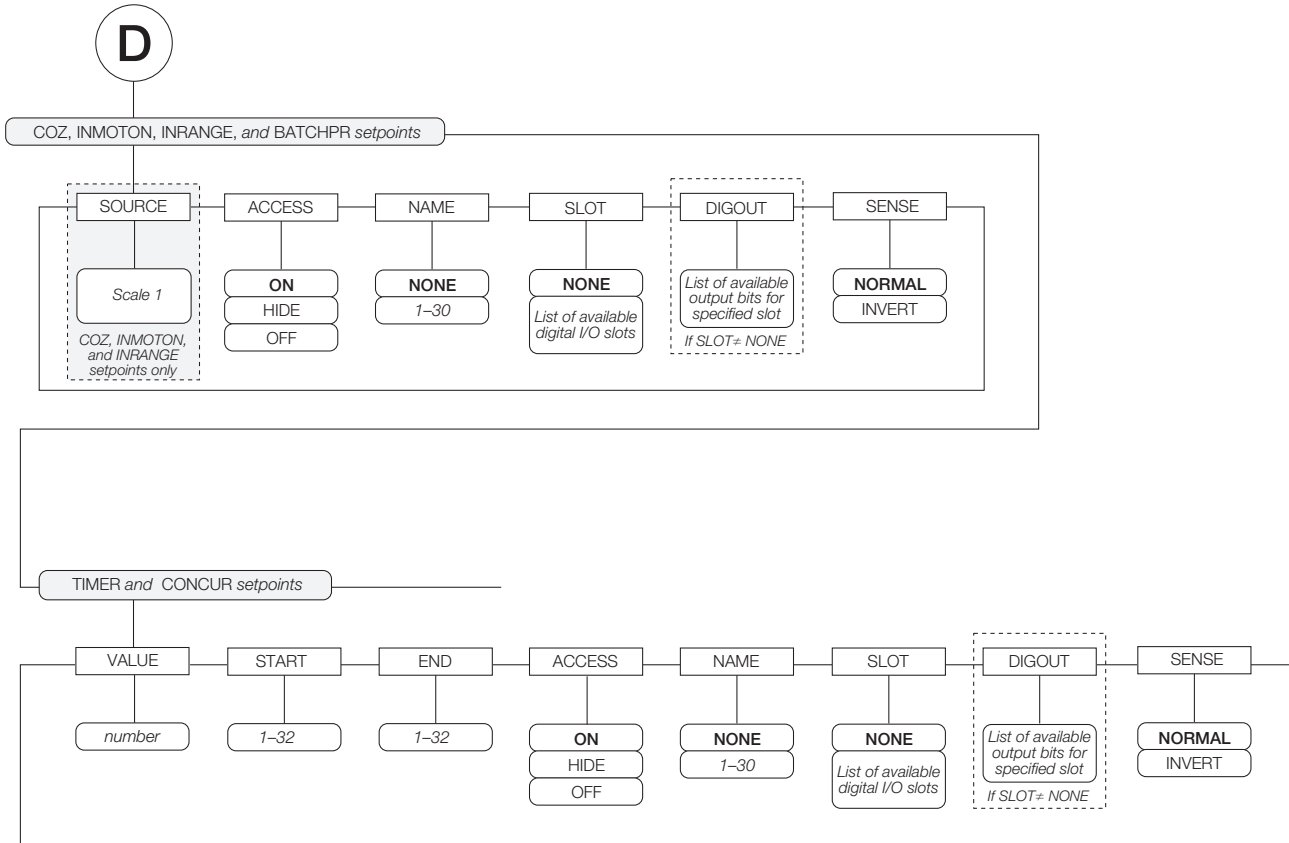

Figure 9-5. COZ, INMOTON, INRANGE, and BATCHPR Setpoint Parameters

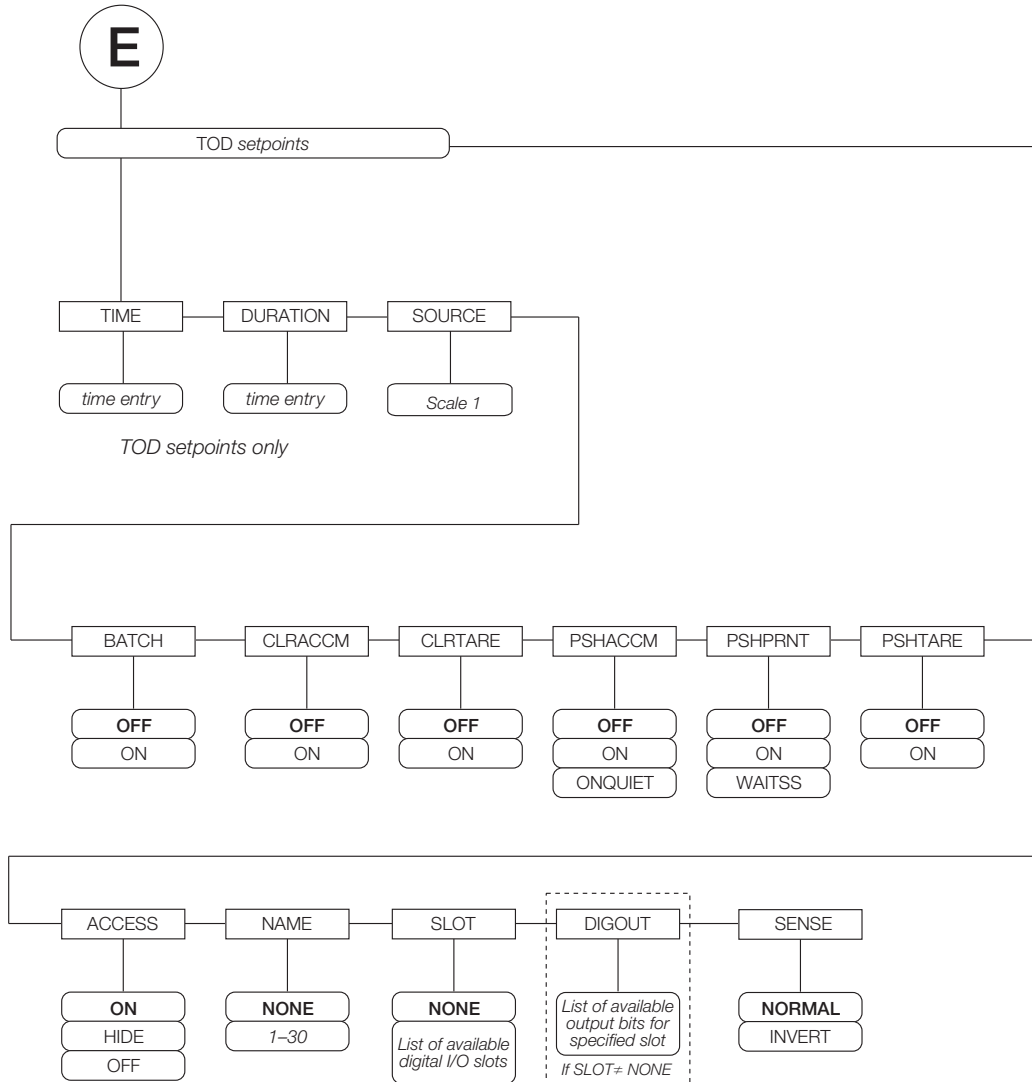

Figure 9-6. TOD Setpoint Parameters

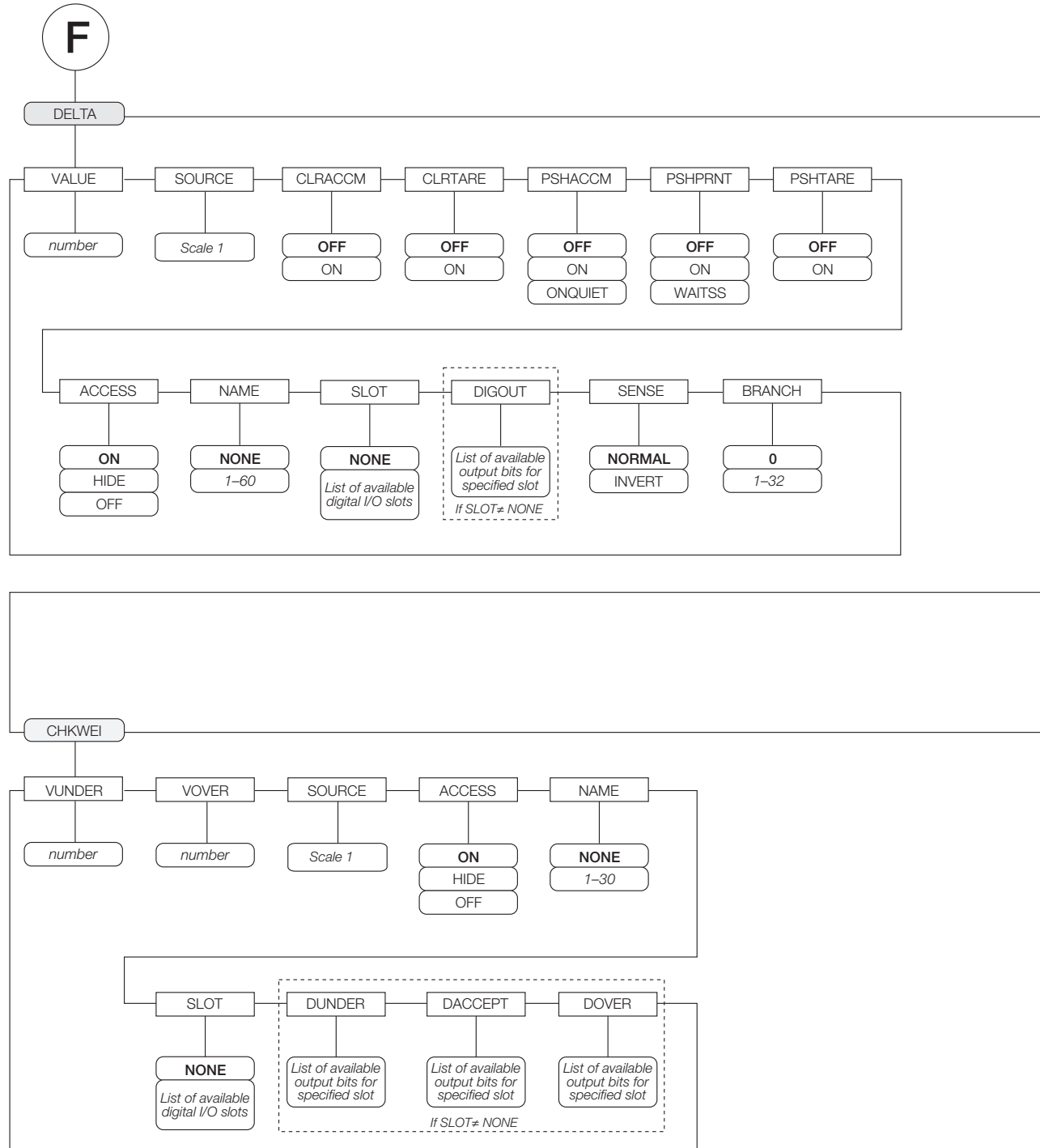

Figure 9-7. DELTA and CHKWEI Setpoint Parameters

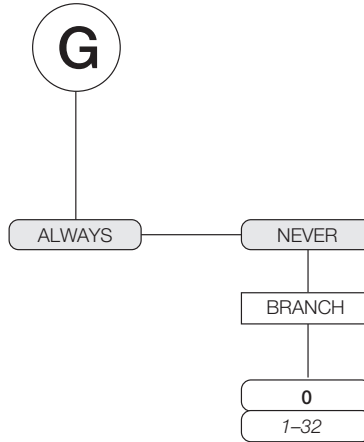

Figure 9-8. ALWAYS and NEVER Setpoint Parameters

SETPTS Menu		
Parameter	Choices	Description
Level 2 Submenus		
SETPT 1– SETPT 32	OFF GROSS NET –GROSS –NET ACCUM ROC +REL –REL %REL RESREL PAUSE DELAY WAITSS COUNTER AUTOJOG COZ INMOTON INRANGE BATCHPR TIMER CONCUR TOD DELTA CHKWEI ALWAYS NEVER	Specifies the setpoint kind; GROSS, NET, –GROSS, –NET, ACCUM, ROC, +REL, –REL, %REL, RESREL. and TOD setpoint kinds can be used as either batch or continuous setpoints; PAUSE, DELAY, WAITSS, COUNTER, AUTOJOG, DELTA, ALWAYS, and NEVER setpoint kinds can only be used in batch sequences; COZ, INMOTON, INRANGE, BATCHPR, TIMER, CONCUR, and CHKWEI setpoint kinds can only be used as continuous setpoints; See Table 9-1 on page 79 for more information about setpoint kinds
BATCHNG	OFF AUTO MANUAL	Batching enable; Set to AUTO or MANUAL to allow a batch sequence to run; MANUAL requires a BATSTRT digital input, BATSTART serial command, Batch Start softkey, or the StartBatch function before the batch sequence can run. AUTO allows batch sequences to repeat continuously

Table 9-2. Setpoint Menu Parameters

SETPTS Menu		
Parameter	Choices	Description
Level 4 Submenus		
VALUE	<i>number</i>	Setpoint value; <ul style="list-style-type: none"> • For weight-based setpoints: Specifies the target weight value, 0–9999999; • For time-based setpoints: Specifies, in 0.1-second intervals, a time value in the range 0–65535; • For COUNTER setpoints: Specifies the number of consecutive batches to be run, 0–65535
SOURCE	<i>source_scale</i>	Specify the scale number used as the source for the setpoint
TRIP	HIGHER LOWER INBAND OUTBAND	Specifies whether the setpoint is satisfied when the weight is higher or lower than the setpoint value, within a band established around the value, or outside of that band; In a batch sequence with TRIP=HIGHER, the associated digital output is active until the setpoint value is reached or exceeded; with TRIP=LOWER, the output is active until the weight goes below the setpoint value
BANDVAL	0–9999999	For setpoints with TRIP=INBAND or OUTBAND, specifies a weight equal to half the band width; The band established around the setpoint value is VALUE ±BANDVAL
HYSTER	0–9999999	Specifies a band around the setpoint value that must be exceeded before the setpoint, once off, can trip on again
PREACT	OFF ON LEARN FLOW	Allows the digital output associated with a setpoint to shut off before the setpoint is satisfied to allow for material in suspension; The ON value adjusts the setpoint trip value up or down (depending on the TRIP parameter setting) from the setpoint value using a fixed value specified on the PREVAL parameter; The LEARN value can be used to automatically adjust the preact value after each batch; LEARN compares the actual weight at standstill to the target setpoint value then adjusts the preact PREVAL by the PREADJ value times the difference after each batch; FLOW preact provides dynamic compensation for material flow rate in determining when to shut off the digital output; Rather than waiting for the specified weight to be reached, FLOW preact uses the change in weight over time to anticipate when the TRIP minus PREACT weight value is reached
PREVAL	0–9999999	Specifies the preact value for setpoints with PREACT set to ON, LEARN, or FLOW; Depending on the TRIP setting specified for the setpoint, the setpoint trip value is adjusted up or down by the PREVAL value
PREADJ	0.500000 0–9999999	Preact adjustment factor; For setpoints with PREACT set to LEARN, specifies a decimal representation of the percentage of error correction applied (0.5 = 50%, 1.0 = 100%) each time a PREACT adjustment is made
PRESTAB	0 0–65535	Preact stabilization time-out; For setpoints with PREACT set to LEARN, specifies the time, in 0.1-second intervals, to wait for standstill before adjusting the PREACT value; Setting this parameter to a value greater than zero disables the learn process if standstill is not achieved in the specified interval
PCOUNT	1 0–65535	Preact learn interval; For setpoints with PREACT set to LEARN, specifies the number of batches after which the preact value is recalculated; The default value, 1, recalculates the preact value after every batch cycle
TOLBAND	0 0–9999999	Tolerance band; For setpoints with TRIP set to HIGHER or LOWER, specifies a tolerance band around the target weight; If the captured weight is not within the specified tolerance band, the preact learn function is not applied and the batch is paused (based on the value of the TOLCNT parameter, below) until restarted or reset
TOLCNT	1 0–65535	Tolerance count; For setpoints with TRIP set to HIGHER or LOWER, specifies the number of consecutive batch cycles in which the tolerance band (TOLBAND parameter) must be exceeded before the batch process is paused; When the specified value is met, the batch is paused and an error message is displayed; The batch must be restarted or reset to clear the error message; The special value of zero means that the batch is never paused for an out-of-tolerance condition
RELNUM	1–32	For relative setpoints, specifies the number of the relative setpoint; The target weight for this setpoint is determined as follows: <ul style="list-style-type: none"> • For +REL setpoints, the value of the relative setpoint plus the value (VALUE parameter) of the +REL setpoint; • For –REL setpoints, the value of the relative setpoint minus the value of the –REL setpoint; • For %REL setpoints, the percentage (specified on the VALUE parameter of the %REL setpoint) of the target value of the relative setpoint; • For RESREL setpoints, the percentage (specified on the VALUE parameter of the RESREL setpoint) of the captured value of the relative setpoint
BATCH	OFF ON	Specifies whether the setpoint is used as a batch (ON) or continuous (OFF) setpoint
CLRACCM	OFF ON	Specify ON to clear the accumulator when the setpoint is satisfied

Table 9-2. Setpoint Menu Parameters (Continued)

SETPTS Menu		
Parameter	Choices	Description
CLRTARE	OFF ON	Specify ON to clear the tare when the setpoint is satisfied
PSHACCM	OFF ON ONQUIET	Specify ON to update the accumulator and perform a print operation when the setpoint is satisfied; Specify ONQUIET to update the accumulator without printing
PSHPRNT	OFF ON WAITSS	Specify ON to perform a print operation when the setpoint is satisfied; specify WAITSS to wait for standstill after setpoint is satisfied before printing
PSHTARE	OFF ON	Specify ON to perform an acquire tare operation when the setpoint is satisfied NOTE: PSHTARE acquires the tare regardless of the value specified for the REGULAT parameter on the FEATURE menu.
NOTE: If two or more of the CLRxxxx and PSHxxxx parameters are set on, the actions specified by those parameters are performed in the following order when the setpoint is satisfied: 1) clear accumulator; 2) clear tare; 3) accumulate; 4) print; 5) acquire tare.		
ALARM	OFF ON	Specify ON to display the word ALARM on the primary display while the setpoint is active (batch setpoints) or while the setpoint is not tripped (continuous setpoints)
START	1–32	Specifies the starting setpoint number; Do not specify the number of the TIMER or CONCUR setpoint itself; The TIMER or CONCUR setpoint begins when the starting setpoint begins
END	1–32	Specifies the ending setpoint number; Do not specify the number of the TIMER or CONCUR setpoint itself; The TIMER or CONCUR setpoint stops when the ending setpoint begins
ACCESS	ON HIDE OFF	Specifies the access allowed to setpoint parameters by pressing the Setpoint softkey in normal mode; ON: Values can be displayed and changed HIDE: Values cannot be displayed or changed OFF: Values can be displayed but not changed
NAME	NONE, 1–60	Specify the number of an assigned prompt; Up to 60 prompt names can be specified on the SETPOINT menu
SLOT	slot_number	Lists all available digital I/O slots; This parameter specifies the slot number of the digital I/O card referenced by the DIGOUT parameter
DIGOUT	bit_number	Lists all digital output bits available for the specified SLOT; This parameter is used to specify the digital output bit associated with this setpoint; Use the DIG I/O menu to assign bit function to OUTPUT; For continuous setpoints, the digital output becomes active (low) when the condition is met; for batch setpoints, the digital output is active until the setpoint condition is met
BRANCH	0 1–32	Specifies the setpoint number to which the batch sequence is to branch if the current setpoint is not satisfied upon initial evaluation; The special value zero indicates that no branch is taken
TIME	time	For TOD setpoints, specifies the time at which the setpoint becomes active; The format used to enter the time (12-hour or 24-hour) is based on the value specified for the TIMEFMT parameter on the FEATURE menu
DURATION	hh:mm:ss	For TOD setpoints, specifies the length of time that the digital output associated with this setpoint changes state; The value is entered in hours, minutes, and seconds (hh:mm:ss); All other operations associated with this setpoint (print, tare, or accumulate) are performed at the end of the specified duration
VUNDER	0–9999999	For CHKWEI setpoints, specifies the lower weight limit
VOVER	0–9999999	For CHKWEI setpoints, specifies the upper weight limit
DUNDER	digital_output	For CHKWEI setpoints, specifies the bit number of digital output activated when the scale weight is less than the VUNDER value specified
DACCEPT	digital_output	For CHKWEI setpoints, specifies the bit number of digital output activated when the scale weight between the VUNDER and VOVER values specified
DOVER	digital_output	For CHKWEI setpoints, specifies the bit number of digital output activated when the scale weight is greater than the VOVER value specified
SENSE	NORMAL INVERT	Specifies whether the value of the digital output associated with this setpoint is inverted when the setpoint is satisfied

Table 9-2. Setpoint Menu Parameters (Continued)

9.3 Batch Operations

Softkeys can be configured to allow operator control of batch operations from the 720i front pane (Figure 9-9). Softkeys can be configured using Revolution, serial commands, or the **FEATURE** menu (Section 4.2.4 on page 50).

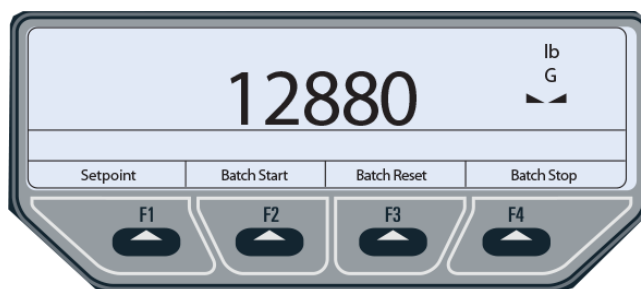

Figure 9-9. Batching Softkeys

Setpoint – Display or change assigned setpoints.

Batch Start – Starts batch process.

Batch Pause – Pauses an active batch and turns off all digital outputs except those associated with concurrent and timer setpoints. Processing is suspended until **Batch Start** is pressed again. Pressing **Batch Start** resumes the batch and re-energizes all digital outputs turned off by the **Batch Pause**.

Batch Reset – Stops and resets an active batch to the beginning of the process.

Batch Stop – Stops an active batch and turns off all associated digital outputs.



WARNING: To prevent personal injury and equipment damage, software-based interrupts must always be supplemented by emergency stop switches and other safety devices necessary for the application.

Batching Switch

The batching switch option (PN 19369) comes as a complete unit in an FRP enclosure, with legend plate, locking stop switch (mushroom button), and a run/start/abort 3-way switch.

Both switches are wired into the indicator's digital I/O terminal strip (Figure 9-11 on page 92).

Each switch uses a separate digital input.

Once cables and switches have been connected to the indicator, use the setup switch to place the indicator in setup mode.

Use the DIG I/O menu to configure digital input and output functions (Section 4.2.6 on page 56).

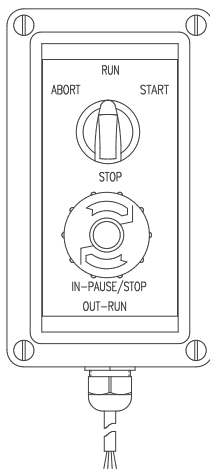

Figure 9-10. Batching Switch

When configuration is complete, exit setup mode. Initialize the batch by turning the 3-way switch to **ABORT** then unlock the **STOP** button (**STOP** must be in the OUT position to allow the batch process to run). The batching switch is now ready to use.



WARNING: If no digital input is assigned to **BATRUN**, batching proceeds as if **BATRUN** were always on: the batch starts when the 3-way switch is turned to **RUN** but the **STOP** mushroom button does not function.

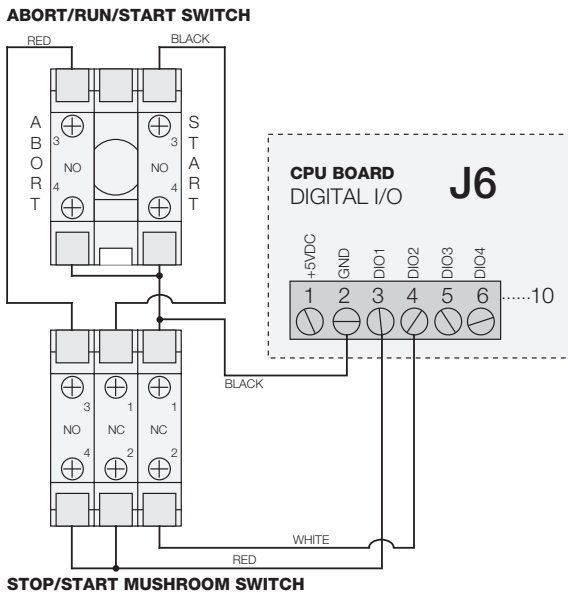

Figure 9-11. Batching Switch Wiring Diagram Example

E-Stop	Start/Abort	Description
Closed	Closed	Starts Batch (Also used as restart)
Closed	Open	--
Open	Closed	Aborts Batch
Open	Open	Pauses Batch

Table 9-3. BATRUN Information



NOTE: If the **STOP** button is pushed in, it is in the open position. If the **STOP** button is pulled out, it is in the closed position.

Digital Input		Softkey		Serial Command
* Start	is the same as	Start	and	Batstart
** Reset	is the same as	Reset	and	Batreset
* Pause	will Pause a batch deactivating Digital Outputs (with the exception of Type 1 Concur outputs) until start is detected	Pause	and	Batpause
*** Stop	is the same as	Stop	and	Batstop
* BatRun (if defined is closed)				
** BatRun is open				
*** Pauses a batch, deactivating all Digital Output				

Table 9-4. Digital IO and Softkey Information



NOTE: Start is also used as a restart. Pause batch continues when Pause Digital Input goes high.

To begin a batch process, turn the 3-way switch to **START** momentarily. If the **STOP** button is pushed during the batch process, the process halts and the button locks in the IN position.

The **START** switch is ignored while the **STOP** button is locked in the IN position. The **STOP** button must be turned counterclockwise to unlock it then released into the OUT position to enable the 3-way switch.

To restart an interrupted batch from the step where it left off, do the following:

1. Unlock **STOP** button (OUT position).
2. Turn 3-way switch to **START**.

To restart an interrupted batch from the first batch step, do the following:

1. Turn 3-way switch to **ABORT**.
2. Unlock **STOP** button (OUT position).
3. Turn 3-way switch to **START**.



NOTE: Use this procedure (or the **BATRESET** serial command) to initialize the new batch routine following changes to the setpoint configuration.

9.4 Batching Examples

9.4.1 Example 1

The following example uses six setpoints to dispense material from a hopper in 100-lb batches and to automatically refill the hopper when its weight drops below 300 lb.

Bits 1 and 2 in the Digital I/O menu ([Section 4.5.9 on page 62](#)) are assigned to batch start and batch run functions: Batch Run must be on (low) before the Batch Start input starts the batch.

Slot 0, Bit 1 = Batch Start

Slot 0, Bit 2 = Batch Run

Batching = Manual

Setpoint 1 ensures the hopper has enough material to start the batch. If the hopper weight is 300 lb or higher, setpoint 1 is tripped.

Setpoint 1	Trip = Higher
Kind = Gross	Alarm = On
Value = 300	Batch = On

Setpoint 2 waits for standstill, then performs a tare to put the indicator into net mode.

Setpoint 2
Kind = Wait Standstill
Push Tare = On

Setpoint 3 is used as a reference (relative setpoint) for setpoint 4.

Setpoint 3	Trip = Higher
Kind = Net	Batch = Off
Value = 0	

Setpoint 4 is used to dispense material from the hopper. When the hopper weight falls to 100 lb less than its weight at the relative setpoint (setpoint 3), digital output 1 is set off.

Setpoint 4	Digital Output = 1
Kind = Negative Relative	Batch = On
Value = 100	Relative Setpoint Number = 3
Trip = Lower	

Setpoint 5 is used to evaluate the gross amount of material in the hopper after dispensing, and to maintain a minimum material level in the hopper. When the hopper weight falls below 300 lb, digital output 2 becomes active and the hopper is refilled to 1,000 lb.

Setpoint 5	Hysteresis = 700
Kind = Gross	Digital Output = 2
Value = 300	Batch = On
Trip = Higher	

Setpoint 6 is used to ensure the operation performed in setpoint 4 is completed within 10 seconds. The Start and End parameters identify the setpoints monitored by the Timer. If the Timer expires before Setpoint 5 starts, Digital Output 4 is turned on as an alarm to signal a process fault.

Setpoint 6	Start = 4
Kind = Timer	End = 5
Value = 100	Digital Output = 4

9.4.2 Example 2

The following example uses six setpoints to control a two-speed fill operation where both fast and slow feeds are on simultaneously.

Bits 1 and 2 in the Digital I/O menu (Section 4.5.9 on page 62) are assigned to Batch Start and Batch Run functions. Batch Run must be on (low) before the Batch Start input starts the batch.

Slot 0, Bit 1 = Batch Start

Slot 0, Bit 2 = Batch Run

Batching = Manual

Setpoint 1 ensures the scale is empty (0 ± 2 lb).

Setpoint 1 Trip = Inband

Kind = Gross Band Value = 2

Value = 0 Batch = On

Setpoint 2 checks for the weight of a container (>5 lb) placed on the scale.

Setpoint 2 Trip = Higher

Kind = Gross Batch = On

Value = 5

Setpoint 3 waits for standstill, then tares the container weight, placing the indicator in net mode.

Setpoint 3

Kind = Wait Standstill

Push Tare = On

Setpoint 4 starts the fast fill operation. When the net weight reaches 175 lb, the setpoint trips and digital output 1 is set off.

Setpoint 4 Trip = Higher

Kind = Net Digital Output = 1

Value = 175 Batch = On

Setpoint 5 controls the slow fill operation. When the net weight reaches 200 lb, the slow fill is stopped, the indicator waits for standstill and performs a push print operation using the Setpoint Format ticket format.

Setpoint 5 Push Print = Wait Standstill

Kind = Net Digital Output = 2

Value = 200 Batch = On

Trip = Higher

Setpoint 6 is a continuous setpoint, used to allow the slow feed output to be on at the same time as the fast fill. The slow fill output (Digital Output 2) is turned on when Setpoint 4 (fast fill) starts and remains on until Setpoint 5 begins.

Setpoint 6 Start = 4

Kind = Concurrent End = 5

Value = 0 Digital Output = 2

10.0 Using ProAction PCEE

This section provides an overview of ProAction PCEE instructions.



NOTE: When working with this chapter, the PCE Version software must be installed.

In addition to Revolution, the 720i is supported by two additional applications that extend its capabilities for batch control and database management. ProAction PCEE, or Process Control Engine Editor, provides functions similar to setpoint configuration for 720i-based batch control. ProAction DBE, the database editor, is a tool for creating, editing and managing databases in the 720i. Both applications are included on the 720i Toolkit CD.

PCEE is developed around a step, condition, and action philosophy.

A step contains conditions and actions (see example below). A condition is a situation that must be met to accomplish the true actions. If the conditions are not met, the false actions are executed. When a transition happens to the condition, the corresponding true or false actions are executed. All actions are executed even after a pause.

Example:

*The condition could be a Weight Compare
(Gross is trip higher than 1000).*

*The false action could be to turn on a digital output
(Digital I/O 1 is On, since weight is below 1000).*

*The true action could be to turn off the digital output
(Digital I/O 1 is Off, since the weight is above 1000).*

Steps are typically sequenced one after another. This is accomplished by actions that allow a step to deactivate itself and to activate other steps. The true action list for the above example is:

- Digital I/O is Off
- Deactivate Step 1
- Activate Step 2

When a step is enabled, the actions are executed once until a condition transitions. This transition can be from true to false, or from false to true. Deactivated steps are not evaluated until activated by another step. When a step is activated (enabled), either the true or false actions are executed.

10.1 Writing a PCE Process

The first step to writing a PCE Process is to decide what small routines are to be built into the total process.

This could include steps for:

- The batch process
- Entering a new target weight
- Printing the weight
- Other functions relating to the process

Before the steps are created, write out the sequence of the process/functions on a worksheet.

Consider the following in working through the details:

- The softkeys or inputs/outputs required
- The steps “enabled” at power-up (at least one is required to start the process)
- Determine the condition to evaluate for each step, and the actions
- What the print formats are going to be
- What database tables need to be created and the data stored in each field

As each step is built, keep in mind the True, False, and Pause lists execute the actions in the order they are listed, meaning an action such as “print” should precede an action such as “tare”.

Steps for a particular routine can be built and tested using just that routine, and when all of the smaller routines are complete, a final merge can be done to finalize the process.

Within the PCE, there are four temporary variables called user data. They are used as an interface between:

- The steps and the database (such as reading or writing data)
- The user and the database (such as searching by an ID)
- The user and the step compares (such as setting a target value)

All data goes through these temporary variables as a “Get” or “Set.” A “Get” is used to get data from a user or from a condition in a step. A “Set” is used to put data into a condition in a step.

Each variable supports a different type of data: integer (whole numbers without a decimal point); real (numbers that can contain a decimal point); string (alphanumeric printable data); and datetime (preset format for the date and time to be stored and printed). There is one location for each type of user data. The User Clear action clears out one of the four variables based on its type.

10.2 Performing a Merge

There are some checks to perform whenever merging is used because the editor assigns condition numbers to each step:

1. Re-Check each step’s Activate and Deactivate to ensure they are still aimed at the correct step.
2. If Set or Get Compare actions are used, verify the condition number, as the editor changes it as a merged process builds.
3. If a Step Compare is used, verify the correct step is being evaluated.



NOTE: *The above checks also apply if a step is moved up or down. If a step is moved, ensure condition numbers are updated accordingly.*

10.3 Pause, Reset, and Restore Process

There are three unique actions that need a bit of clarification: the Pause Process, Reset Process, and Restore Process. These actions are used to pause the process then either restore (continue) or reset (abort) the process. These actions are typically accomplished with a softkey or a digital input.

These actions only affect the steps that have the Pausable flag set. Setting this flag in the actual process steps means only those steps are affected. When a Pause Process is initiated, only the pause actions for the current step (or other enabled, pausable steps) are run. Those steps without the pausable flag set still operate as normal. For example, a free-running independent weight compare or non-pausable, enabled step can continue to activate/deactivate other non-pausable steps.

A Pause stops the pausable steps. The state of each step is then saved. If a Restore is then executed, the steps’ states are restored and the process continues where it left off. If the Reset action is executed, all pausable steps go back to the default state and the process needs to be manually restarted based on the setup of the process.

Along with the PCE Editor, there is also a Database Editor to build and download a database that can be used by PCEE. First a Schema is built. This is the framework of the database. This includes the name, number of fields, and the type of data each field contains. This data can be used for displaying prompts, gathering data during a batch process, and as a warehouse for data that the PCE needs to use.

Use of the database is addressed using the database commands discussed later in this document.

10.4 Revolution

Whenever a PCE process is built, be sure to build a Revolution hardware configuration file using the 720i module so that all configuration parameters match the process. The Revolution file defines the required digital i/o, softkeys, and the print formats (AuxFmt) used.

In Revolution, there is a Monitor Mode in the **Tools** tab of the editor, which can be used to set individual parameters such as a DigOut to Output or Input.

10.5 Setting Up a Simple Three-Step Fill

The following example sets up three steps to start the process with DigIn 1, turn on DigOut 2 until the target is reached (100 lbs), and wait for the scale to empty before allowing a restart.

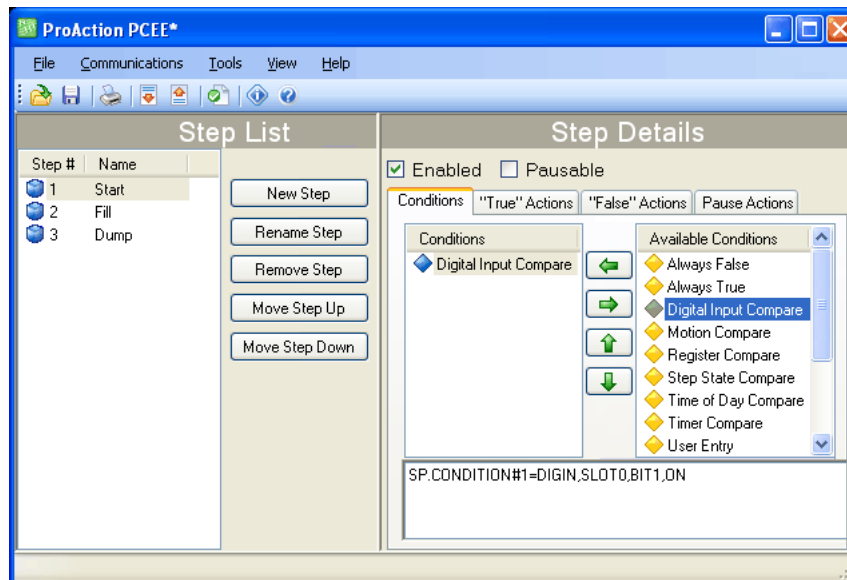

Figure 10-1. ProAction PCEE Window

To create this process:

1. Install both the PCEE program and the DBE program.
2. Open the PCEE program.
3. Select the **New Step** button. The **Step** dialog box appears.
4. In the **Step Name** text box, type the desired name for this step.
5. Ensure **Auto-Sequence** is checked.
6. Select **OK**. The step displays in the left column and the **Auto-Sequence** adds the **Deactivate** for this step and an **Activate** for the next step.
7. Select **Enable** to set the default to **Enabled** for this step.
8. Under **Available Conditions**, select **Digital Input Compare**.
9. Select the **Left Arrow** button. This uses a DigIn to start this process.
10. Select bit 1 in the parameter section and **ON** for Target State.
11. Using Revolution, ensure that DIO bit 1 on Slot 0 is set to INPUT.
12. Click **New Step** to create the second step and name it.
13. Under **Available Conditions**, select **Weight Compare**.
14. Select the **Left Arrow** button.
15. Set the parameters to Higher and a value of 100. Do not use a Preact right now. This is the fill step.
16. Select the **True Actions** tab.
17. Select **Digital Output**.
18. Select the **Left Arrow** button.
19. In the parameters, set to bit 2 then select **OFF**. This turns the relay off when the target is reached.
20. Select **Digital Output**.
21. Select the **Left Arrow** button.
22. Set the parameters to bit 2 then select **ON**. This turns the relay on until the target is reached.

23. Using Revolution, ensure that DIO bit 2 is set to **OUTPUT**.
24. Select the **New Step** button for the final step and name it.
25. Under **Available Conditions**, click on **Weight Compare** then click the **Left Arrow**.
26. Set the parameters to **Lower** and a value of 5. This is the dump step.
27. Under the true actions of [Step 3 on page 97](#), adjust the activate to [Step 1 on page 97](#) instead of [Step 4 on page 97](#). Auto Sequence continues to enable a next step
28. From the **Tools** menu, select **Validate** to check the process steps for basic errors.
29. From the **File** menu, select **Save As...**
30. Name the file then select a save location.
31. Open Revolution and connect to 720i.
32. Place 720i in configuration mode.
33. Download the matching Revolution file.
34. Download the file saved in [Step 29](#).
35. Select **SaveExit** on the 720i to open and execute these files.
36. Verify all operations of the files.

For ease in the debugging process, there is an EDP command that dumps the raw list of commands which have been sent to the 720i, "SPSUMP." The first half of the list is all the conditions and actions. The second half lists the steps and associated conditions and actions by numeric reference.



NOTE: The Enable flag is True for the steps that are presently active. If they were set to ENABLED on download and no other step ever turns it off, it should still be ENABLED. If it was off at download and is part of a process sequence then it may be on now to represent where the process is at this time. The EDP command can be used every step of the process to watch the progress. It is very useful.

10.6 Helpful Hints

PCE has a special feature called auto-sequence that, when enabled, automatically adds an Activate and Deactivate action to the current step. This is used to consecutively enable and disable steps in a routine to form a process flow.

The Enable is a preset flag that is set to activate a step on a download or reset. That is its default state. A Restore always puts this flag back to a default state when processed. It can also be turned ON or OFF from other steps to form a sequence of steps. If it stays on and no other step turns it off, it can be considered free-running and is always examined by the PCE.

The Pausable flag is used for steps to be included in a pause action. If the process needs to be paused, this pause list in each pausable step is executed. This flag also marks steps to be included in a Reset action to put them back to its default state, particularly to put the enable flag back to its default state.

The Reset Process with reset all pausable steps back to the downloaded default settings. If a pause was not performed prior to this action, it is performed then the reset is done.

The Restore action sets all paused steps back to where they were when the pause was executed so the process can continue where it left off.

There are 32 timers that are used as a "one-shot timer." They can be started inside a step then another step can use a Timer Compare to check if the timer is still running or stopped, and perform the appropriate actions based on the timer's state.

A simple hint for naming the steps is to insert a character or number before the step name:

Example: "A. Start."

The next step would then be "A. Setup," This routine is then saved as group of steps and the next routine can be built with a prefix of "B." When the merge is done, this simplified identifying which steps are grouped together in the total process.

A simple Weight Compare step would have a Weight Compare condition of Higher than a Target with the false action setting a digital output to ON, and the true action would turn the digital output OFF when the Compare is true.



NOTE: Once a negative value is used for a Weight Compare, a new value set from a Set Compare retains the negative sign.

Within the Weight Compare steps we can add actions that are the same as the old setpoints used, such as Tare Scale, Clear Tare, Accumulate, Clear Accumulator, and Turn a Digital Output On or OFF.

Whenever a User Get action is used, it should be used with a User Entry condition as the next step. The User Get prompts the user for a new value. At this time, an Activate should start a new step with the User Entry condition that pauses processing of this stream of steps until the operator presses either the **Enter** key or a **Cancel** key. This ensures the process has the requested data before it continues.

Printing can be done by using a Print action and selecting one of 20 AuxFmts. These formats can be configured using Rev III to print anything required. The <USx> strings can be added to all formats and there are 99 of these to use. A Set User Print Text fills these fields. They are strings but all types of data, (real, integer, string or DT) can be inserted and the 720i converts it to a printable string.

Registers are a group of 256 variable registers used to hold a number that can be incremented or decremented as a counter. There is also a Clear Register (only 1) and a Clear Register All (all of them).

Math functions of Add, Subtract, Multiply and Divide are supplied and used as follows:

- There are two sources for the data to be worked with: **Immediate** is the value within the step to be used and **Database** is the field of the data to be used; This source is then added, subtracted and others, from the user variables; The result is then left in the user variable so it can be either printed or written to the database; Also only Integers and real variables can be used

10.7 Database Information

A Database consists of a group of fields that comprise a record; Record 1 = F1, F2, F3, F4, F5 and others.

Record 2 = F1, F2, F3, F4, F5 and others

To ensure a simple search, try to make Field 1 an integer to be used as an index number. This allows to search for an index then get the other fields as needed or insert data to them after a successful search.

A **Sort** of the database by index sorts all records by the index and place them in order. This is not mandatory, but makes working with a database much easier.

The database index is the database number assigned from the Database Editor. DB 1 is the embedded Truck Database for Weigh In / Weigh out functions. The next is DB 2 which is the first PCE database that can be used. Eight databases are allowed, but as the number increases the size of each is reduced. Slot is usually 0 as memory card expansion options are not allowed in the 720i.

There are two actions that are similar but need further definition. They are the DB Write and DB Capture. The DB Write puts a user variable into a field specified by the step. The DB Capture puts a captured value specified by the step into a database field. Captured data can be trip weight from a Weight Compare condition, Weight Compare preact value, motion status, timer state, DigIn or step state, current time and date, or a current register value.

Add Record, Delete Record, and Copy Record pertains to the complete record with all fields involved.

DB Write, DB Read, and DB Clear only affect the specified field of the current record.

A Set Compare or Get Compare is the method used to either retrieve the Compare value or set it to a new value. These values would be such as a Weight Compare (Trip) value. This is assigned to a condition number, not a step number. This is because a step could have multiple conditions of similar type so we need to aim at the exact condition.

From the **Tools** menu, there is a selection for **Text View**. There is also a keyboard shortcut of **CTRL+T**.

We can go look at the condition we want to Set or Get then switch to **Text View** to see the exact condition number to assign. Hover the mouse over conditions to display an ID number which is also the condition number.

Example of a Text View would be: SP.CONDITION#5=WEIGHT,SCALE1,GROSS,0,HIGHER,OFF,0.

With this example, we would assign our Set Compare to condition 5. Also a Set or Get Compare can come from a user variable after a User Get or from the Database from a specified field.

11.0 Serial Commands

The 720i indicator can be controlled by a personal computer or remote keyboard connected to an indicator serial port. Control is provided by a set of serial commands that can simulate front panel key press functions, display and change setup parameters, and perform reporting functions. The serial commands provide the capability to print configuration data or to save that data to an attached personal computer. This section describes the serial command set and procedures for saving and transferring data using the serial ports.

11.1 The Serial Command Set

The serial command set can be divided into five groups: key press commands, reporting commands, the RESETCONFIGURATION special function command, parameter setting commands, and transmit weight data commands.

When the indicator processes a serial command, it responds with the message **OK**. The **OK** response verifies that the command was received and has been executed. If the command is unrecognized or cannot be executed, the indicator responds with **??**.

The following sections list the commands and command syntax used for each of these groups.

11.1.1 Key Press Commands

Key press serial commands simulate pressing the keys on the front panel of the indicator (Table 11-1). These commands can be used in both setup and normal (weighing) mode. Several of the commands serve as “pseudo” keys, providing functions that are not represented by a key on the front panel.

For example, to enter a 15-pound tare weight using serial commands:

1. Type K1 then press **Enter** (or **RETURN**).
2. Type K5 then press **Enter**.
3. Type KTARE then press **Enter**.

Command	Description
KZERO	In normal mode, press the ZERO key
KGROSSNET	In normal mode, press the GROSS/NET key
KGROSS	Go to gross mode (pseudo key)
KNET	Go to net mode (pseudo key)
KTARE	Press the TARE key
KUNITS	In weighing mode, press the UNITS key
KPRIM	Go to primary units (pseudo key)
KSEC	Go to secondary units (pseudo key)
KTER	Go to tertiary units (pseudo key)
KPRINT	In normal mode, press the PRINT key
KDISPACCUM	Display Accumulator (pseudo key)
KDISPTARE	Display tare (pseudo key)
KCLR	Press the CLEAR key
KLRCN	Reset consecutive number (pseudo key)
KCLRTAR	Clear tare from system (pseudo key)
KLEFT	In setup mode, move left in the menu
KRIGHT	In setup mode, move right in the menu
KUP	In setup mode, move up in the menu; in normal mode, scroll up to previous configured scale
KDOWN	In setup mode, move down in the menu; in normal mode, scroll down to the next configured scale

Command	Description
KSAVE	In setup mode, saves the current configuration
KSAVEEXIT	In setup mode, saves the current configuration then exits to normal mode
KCLRNV	In setup mode, clears non-volatile RAM
K0–K9	Press number key 0–9
KDOT	Press the decimal point key (.)
KENTER	Press the Enter key
KSOFTx	Press softkey number x
KLOCK	Lock specified front panel key; <i>Example: To lock the ZERO key, enter KLOCK=KZERO</i>
KUNLOCK	Unlock specified front panel key <i>Example: To unlock the PRINT key, enter KUNLOCK=KPRINT</i>
KTREG	Display truck register (pseudo key)
*KWIN	Process truck weigh-in transaction <i>Example: KWIN, K2, K3, KENTER to select ID #23)</i>
*KWOUT	Process truck weigh-out transaction
KDEL	While truck register is displayed, delete truck register
KDATE	Display date (pseudo key)
KTIME	Display time (pseudo key)
KTIMEDATE	Display time and date (pseudo key)
* Truck Modes 1–6 only	

Table 11-1. Serial Key Press Commands

11.1.2 Reporting Commands

Reporting commands send specific information to the serial port. The commands listed in [Table 11-2](#) can be used in both setup mode and normal mode.

Command	Description
DUMPALL	List all parameter values
DUMPAUDIT	List audit trail information
SPDUMP	List <i>PCEE</i> configuration or list setpoint configuration for the 720iB
VERSION	Write 720i software version
HARDWARE	Lists installed option cards; See Section 12.1.2 on page 114 for more information about using the HARDWARE command
XE	Returns a 10-digit code representing error conditions currently on the front panel; See Section 12.1.5 on page 115 for more information

Table 11-2. Reporting Commands

11.1.3 Clear and Reset Commands

The following commands can be used to clear and reset the 720i:

RS – Reset system. Resets the indicator without resetting the configuration.

RESETCONFIGURATION – Restores all configuration parameters to their default values (setup mode only).

The **RESETCONFIGURATION** function can also be initiated by pressing the **Reset Config** softkey under the VERSION menu. Use the **Up** key to select **Clear entire indicator configuration** then press **Enter** to reset the indicator.



NOTE: All load cell calibration settings are lost when the **RESETCONFIGURATION** command is run.

11.1.4 Parameter Setting Commands

Parameter setting commands allow to display or change the current value for a particular configuration parameter ([Table 11-3](#) through [Table 11-10 on page 107](#)).

Current configuration parameter settings can be displayed in either setup mode or normal mode using the following syntax: **command<ENTER>**

Most parameter values can be changed in setup mode only.

Use the following command syntax when changing parameter values: **command=value<ENTER>**, where **value** is either a number or a parameter value. Use no spaces before or after the equal (=) sign. If an incorrect command is entered, the display reads **??**.

For example, to set the motion band parameter on Scale #1 to 5 divisions, type the following:

SC.MOTBAND#1=5<ENTER>

For parameters with selectable values, enter the command and equal sign followed by a question mark: **command=?<ENTER>** to see a list of those values. The indicator must be in setup mode to use this function.



NOTE: Some parameters are valid only if other parameters or parameter values are specified. See the configuration menus in [Section 4.2 on page 34](#) for information about parameter dependencies. Restrictions for front-panel configuration also apply to serial command configuration.

Command	Description	Values
SC.GRADS#1	Graduations	1–999999
SC.SPLIT#1	Multi-range or multi-interval scale type	OFF, 2RNG, 3RNG, 2INTVL, 3INTVL
SC.ZTRKBND#1	Zero track band	0, 0–100
SC.ZRANGE#1	Zero range	1.900000, 0–100
SC.MOTBAND#1	Motion band	1, 0–100
SC.SSTIME#1	Standstill time	1–65535
SC.OVRLOAD#1	Overload	FS+2%, FS+1D, FS+9D, FS

Table 11-3. SCALES Serial Commands

Command	Description	Values
SC.WMTTHR#1	Weighment threshold	grads
SC.NUMWEIGH#1	Number of weighments	—
SC.MAX_WEIGHT#1	Maximum weight	—
SC.DIGFLTR1#1 SC.DIGFLTR2#1 SC.DIGFLTR3#1	Digital filtering	1, 2, 4, 8, 16, 32, 64, 128, 256
SC.DFSENS#1	Digital filter cutout sensitivity	2OUT, 4OUT, 8OUT, 16OUT, 32OUT, 64OUT, 128OUT
SC.DFTHR#1	Digital filter cutout threshold	NONE, 2D, 5D, 10D, 20D, 50D, 100D, 200D, 250D
SC.RATLTRAP#1	Rattletrap filtering	OFF, ON
SC.SMPRAT#1	Sample rate	7.5HZ, 15HZ, 30HZ, 60HZ, 120HZ, 240HZ, 480HZ, 960HZ
SC.PWRUPMD#1	Power up mode	GO, DELAY
SC.TAREFN#1	Tare function	BOTH, NOTARE, PBTARE, KEYED
SC.PRI.DECPNT#1	Primary units decimal position	8.888888, 88.88888, 888.8888, 8888.888, 88888.88, 888888.8, 8888888, 8888880, 8888800
SC.PRI.DSPDIV#1	Primary units display divisions	1D, 2D, 5D
SC.PRI.UNITS#1	Primary units	LB, KG, G, OZ, TN, T, GR, troyoz, troylb, LT, CUSTOM, NONE, OFF
SC.PRI.CUNITS#1	Primary custom units	Specify units if SC.PRI.UNITS=CUSTOM
SC.SEC.DECPNT#1	Secondary units decimal position	8.888888, 88.88888, 888.8888, 8888.888, 88888.88, 888888.8, 8888888, 8888880, 8888800
SC.SEC.DSPDIV#1	Secondary units display divisions	1D, 2D, 5D
SC.SEC.UNITS#1	Secondary units	LB, KG, G, OZ, TN, T, GR, troyoz, troylb, LT, CUSTOM, NONE, OFF
SC.SEC.CUNITS#1	Secondary custom units	Specify units if SC.SEC.UNITS=CUSTOM
SC.SEC.MULT#1	Secondary units multiplier	0.00000–999999
SC.TER.UNITS#1	Tertiary units	LB, KG, G, OZ, TN, T, GR, troyoz, troylb, LT, CUSTOM, NONE, OFF
SC.TER.CUNITS#1	Tertiary custom units	Specify units if SC.TER.UNITS=CUSTOM
SC.TER.DECPNT#1	Tertiary units decimal position	8.888888, 88.88888, 888.8888, 8888.888, 88888.88, 888888.8, 8888888, 8888880, 8888800
SC.TER.DSPDIV#1	Tertiary units display divisions	1D, 2D, 5D
SC.TER.MULT#1	Tertiary units multiplier	0.000001–9999999
SC.ROC.DECPNT#1	Tertiary units decimal position	8.888888, 88.88888, 888.8888, 8888.888, 88888.88, 888888.8, 8888888, 8888880, 8888800
SC.ROC.DSPDIV#1	Rate-of-change units display divisions	1D, 2D, 5D
SC.ROC.MULT#1	Rate-of-change units multiplier	0.000001–9999999
SC.ROC.UNITS#1	Rate-of-change units	SEC, MIN, HOUR
SC.ROC.INTERVL#1	Rate-of-change interval	1–100
SC.ROC.REFRESH#1	Rate-of-change refresh interval	0.1–60
SC.RANGE1.MAX#1	Weight maximum for first range or interval	<i>weight</i>
SC.RANGE2.MAX#1	Weight maximum for second range or interval	<i>weight</i>
SC.RANGE3.MAX#1#1	Weight maximum for third range or interval	<i>weight</i>
SC.ACCUM#1	Accumulator enable	ON, OFF
SC.VISIBLE#1	Scale visibility	ON, OFF
SC.PEAKHOLD#1	Peak hold	OFF, NORMAL, BI-DIR, AUTO
SC.WZERO#1	Zero calibration	—
SC.WVAL#1	Test weight value	test_weight_value
SC.WSPAN#1	Span calibration	—
SC.WLIN.F1#1– SC.WLIN.F5#1	Actual raw count value for linearization points 1–5	0–16777215

Table 11-3. SCALES Serial Commands (Continued)

Command	Description	Values
SC.WLIN.V1#1– SC.WLIN.V5#1	Test weight value for linearization points 1–5	0.000001–9999999
SC.WLIN.C1#1– SC.WLIN.C5#1	Calibrate linearization points 1–5	—
SC.LC.CD#1	Deadload coefficient	—
SC.LC.CW#1	Span coefficient	—
SC.LC.CZ#1	Temporary zero	—
SC.REZERO#1	Rezero	—

Table 11-3. SCALES Serial Commands (Continued)

Command	Description	Values
EDP.PORT	Active serial port	Returns number of port being used for serial command input
EDP.INPUT#p	Port serial input function	CMD, KEYBD, SCALE, IND SC
EDP.BAUD#p	Port baud rate	300, 600, 1200, 2400, 4800, 9600, 19200, 28800, 38400, 57600, 115200
EDP.BITS#p	Port data bits/parity	8NONE, 7EVEN, 7ODD, 8ODD, 8EVEN
EDP.TERMIN#p	Port termination character	CR/LF, CR
EDP.STOPBITS#p	Port stop bits	2, 1
EDP.ECHO#p	Port echo	ON, OFF
EDP.RESPONSE#p	Port response	ON, OFF
EDP.EOLDLY#p	Port end-of-line delay	0–255 (.01-second intervals)
EDP.HANDSHK#p	Port handshaking	OFF, XONXOFF, HRDWAR
EDP.PORTTYPE#p	Port type	232, 485 (Port 7 only)
EDP.DUPLEX#p	Port RS-485 duplex	HALF, FULL
EDP.ADDRESS#p	Port RS-485 address	0, 1–255
EDP.STREAM#p	Port streaming	OFF, LFT, INDUST, 4KEYS, KEYPAD
EDP.SOURCE#p	Port source scale for output	scale number
EDP.SFMT#p	Port custom stream format	0-50 characters
STR.POS#p	Custom stream identifiers	Specify replacement text for token Example: STR.PRI#1=L Stream tokens can be configured via Serial Commands but not within the menus See Section 12.6 on page 121 for more information about custom stream formatting
STR.NEG#p		
STR.PRI#p		
STR.SEC#p		
STR.TER#p		
STR.GROSS#p		
STR.NET#p		
STR.TARE#p		
STR.MOTION#p		
STR.RANGE#p		
STR.OK#p		
STR.INVALID#p		
STR.ZERO#p		
For commands including “#p”, p is the serial port number		

Table 11-4. SERIAL Port Serial Commands

Command	Descriptions	Values
SD	Set date	MMDDYY, DDDMMYY, YYMMDD, or YYDDMM ; Enter six-digit date using the year-month-day order specified for the DATEFMT parameter, using only the last two digits of the year
ST	Set time	hhmm (enter using 24-hour format)
DATEFMT	Date format	MMDDYYYY, DDDMMYYYY, YYYYMMDD, YYYYDDMM
DATESEP	Date separator	SLASH, DASH, SEMI
TIMEFMT	Time format	12HOUR, 24HOUR
TIMESEP	Time separator	COLON, COMMA
DECFMT	Decimal format	DOT, COMMA
CONSNUM	Consecutive numbering	0-9999999
CONSTUP	Consecutive number start-up value	0-9999999
TRUCK	Truck in/out mode	OFF, MODE1, MODE2, MODE3, MODE4, MODE5, MODE6, ADVANCE
ALIBI	Alibi data storage enable	OFF, ON
ALIBI.ERASE.ALL	To clear all entries	-
CFGPWD	Configuration password	0, 1-9999999
SK#1-SK#10	Softkey assignment	Blank, TimeDate, DspTar, DspAcc, DspROC, WeighIn, WeighOut, TrkReg, Alibi, Setpoint*, Batch Start*, Batch Stop* Batch Pause*, Batch Reset*, Weigh, Reports, Management
SKT#1-SKT#10	User-defined softkey text	-
KYBDLK	Keyboard lock (disable keypad)	OFF, ON
ZERONLY	Disable all keys except ZERO	OFF, ON
REGULAT	Regulatory compliance	NONE, OIML, NTEP, CANADA, INDUST
REG.SNPSHOT	Display or Scale weight source	DISPLAY, SCALE
REG.HTARE	Allow tare in display hold	NO, YES
REG.ZTARE	Remove tare on ZERO	NO, YES
* 720i Batch Version Software only		
REG.KTARE	Always allow keyed tare	NO, YES
REG.MTARE	Multiple tare action	REPLACE, REMOVE, NOTHING
REG.NTARE	Allow negative tare	NO, YES
REG.CTARE	Allow clear keyed tare	NO, YES
REG.PRTMOT	Allow print while in motion	NO, YES
REG.PRINTPT	Add PT to keyed tare print	NO, YES
REG.PRTHLD	Print during display hold	NO, YES
REG.HLDWGH	Allow weighment during display hold	NO, YES
REG.MOTWGH	Allow weighment in motion	NO, YES
REG.BASE	Zero base for overload calculation	CALIB, SCALE
REGWORD	Regulatory word	GROSS, BRUTTO
HEARTBEAT	Display module heartbeat	0, 1-8 (0.5-second intervals; 4 = 2.0 seconds)
CONTACT.COMPANY	Contact company name	company_name (up to 30 characters)
CONTACT.ADDR1 CONTACT.ADDR2	Contact company address	company_address (up to 30 characters for each line)
CONTACT.NAME1 CONTACT.NAME2	Contact names	contact_names (up to 20 characters each)
CONTACT.PHONE1 CONTACT.PHONE2	Contact phone numbers	contact_phone_numbers (up to 20 characters each)
CONTACT.EMAIL	Contact e-mail address	contact_e-mail_address (up to 30 characters)
CONTACT.NEXTCAL	Next calibration date	calibration_date
GRAVADJ	Gravitational adjustment	OFF, ON
LAT.LOC	Latitude	0-90 (to nearest degree of latitude)
ELEV.LOC	Elevation	±0-9999 (in meters)

Table 11-5. FEATURE Serial Commands

Command	Description	Values
GFMT.FMT GFMT.PORT	Gross demand print format string	For .PORT commands, specify the port number as PORT xx (no leading zero)
NFMT.FMT NFMT.PORT	Net demand print format string	<i>Example: GFMT.PORT=PORT2</i>
ACC.FMT ACC.PORT	Accumulator print format string	For AUXFMT.FMT commands, specify the auxiliary format number (1—20) as AUXFMT xx (no leading zero)
TRWIN.FMT TRWIN.PORT	Truck weigh-in print format string	<i>Example: AUXFMT.FMT#8=GROSS<G><NL>...</i>
TRWOUT.FMT TRWOUT.PORT	Truck weigh-out print format string	See Section 7.0 on page 65 for information about demand print format strings.
TR.FMT TR.PORT	Truck register print format string	
ALERT.FMT ALERT.PORT	Alert format string	
HDRFMT1 HDRFMT2	Ticket header format strings	
AUXFMT.FMT# x AUXFMT.PORT# x	Auxiliary ticket format	

Table 11-6. PFORMT Serial Commands

Command	Description	Values
DIO. $b#s$	Digital input function	OFF, INPUT, OUTPUT, PROGIN, ZERO, NT/GRS, TARE, UNITS, PRINT, ACCUM, SETPNT, TIMDATE, ESC, CLEAR, DSPTAR, KEY0–KEY9, KEYDP, ENTER, NAVUP, NAVDN, NAVLFT, NAVRGT, KBDLOC, HOLD, BATRUN*, BATSTRT*, BATPAUS*, BATRESET*, BATSTOP*, CLRCN, GROSS, NET, PRIM, SEC, CLRTAR, CLRACC

* 720i Batch Version Software only

NOTE: Digital inputs and outputs are specified by bit number (b) and slot number (s).

Table 11-7. DIG I/O Serial Commands

Command	Description	Values
ALG.ALIAS# n	Analog output alias	name
ALG.SOURCE# n	Analog output source	SCALE n
ALG.MODE# n	Mode	GROSS, NET
ALG.OFFSET# n	Zero offset	0%, 20%
ALG.ERRACT# n	Error action	FULLSC, HOLD, ZEROOSC
ALG.MIN# n	Minimum value tracked	0–9999999
ALG.MINNEG# n	Minimum negative value tracked	OFF, 0–9999999
ALG.MAX# n	Maximum value tracked	0–9999999
ALG.MAXNEG# n	Maximum negative value tracked	OFF, 0–9999999
ALG.ZERO# n	Zero calibration	0–65535
ALG.SPAN# n	Span calibration	0–65535

n indicates the slot number assigned to the analog output; Single-channel cards are assigned ALGOUT2

Table 11-8. ALGOUT Serial Commands (Valid Only If Analog Output Card Is Installed)

Command	Description	Values
SP.KIND# <i>n</i>	Setpoint kind	OFF, GROSS, NET, -GROSS, -NET, ACCUM, ROC, +REL, -REL, %REL, RESREL, PAUSE, DELAY, WAITSS, COUNTER, AUTOJOG, COZ, INMOTON, INRANGE, BATCHPR, TIMER, CONCUR, DIGIN, AVG, TOD, DELTA, CHWEI, PLSCNT, PLSRAT, ALWAYS, NEVER, DINCNT
SP.VALUE# <i>n</i>	Setpoint value	<i>number</i>
SP.SOURCE# <i>n</i>	Source scale	SCALE1
SP.COAST# <i>n</i>	Pulse counter coast	<i>number</i>
SP.TRIP# <i>n</i>	Trip	HIGHER, LOWER, INBAND, OUTBAND
SP.BANDVAL# <i>n</i>	Band value	<i>number</i>
SP.HYSTER# <i>n</i>	Hysteresis	<i>number</i>
SP.PREACT# <i>n</i>	Preact type	OFF, ON, LEARN, FLOW
SP.PREVAL# <i>n</i>	Preact value	<i>number</i>
SP.PREADJ# <i>n</i>	Preact adjustment percentage	<i>number</i>
SP.PRESTAB# <i>n</i>	Preact learn stability	<i>number</i>
SP.PCOUNT# <i>n</i>	Preact learn interval	<i>number</i>
SP.TOLBAND# <i>n</i>	Target tolerance	<i>number</i>
SP.TOLCNT# <i>n</i>	Tolerance count	<i>number</i>
SP.BATCH# <i>n</i>	Batch step enable	OFF, ON
SP.CLRACCM# <i>n</i>	Clear accumulator enable	OFF, ON
SP.CLRTARE# <i>n</i>	Clear tare enable	OFF, ON
SP.PSHACCM# <i>n</i>	Push accumulate	OFF, ON, ONQUIET
SP.PSHPRINT# <i>n</i>	Push print	OFF, ON, WAITSS
SP.PSHTARE# <i>n</i>	Push tare	OFF, ON
SP.ALARM# <i>n</i>	Alarm enable	OFF, ON
SP.NAME# <i>n</i>	Setpoint name number	NONE, 1-30
SP.ACCESS# <i>n</i>	Setpoint access	OFF, ON, HIDE
SP.DSLOT# <i>n</i>	Digital output slot	NONE, SLOT <i>x</i>
SP.DIGOUT# <i>n</i>	Digital output	BIT <i>x</i>
SP.SENSE# <i>n</i>	Digital output sense	NORMAL, INVERT
SP.BRANCH# <i>n</i>	Branch destination	0, 1-32
SP.RELNUM# <i>n</i>	Relative setpoint number	1-32
SP.START# <i>n</i>	Starting setpoint	1-32
SP.END# <i>n</i>	Ending setpoint	1-32
SP.DISLOT# <i>n</i>	Digital input slot	NONE, SLOT <i>x</i>
SP.MASK# <i>n</i>	Digital input mask	<i>number</i>
SP.NSAMPLE# <i>n</i>	Number of samples	<i>number</i>
SP.TIME# <i>n</i>	Trip time	<i>hhmm</i>
SP.DURATION# <i>n</i>	Trip duration	<i>hhmmss</i>
SP.VUNDER# <i>n</i>	Underrange value	<i>number</i>
SP.VOVER# <i>n</i>	Overrange value	<i>number</i>
SP.DUNDER# <i>n</i>	Underrange digital output	BIT <i>x</i>
SP.DACCEPT# <i>n</i>	Accept digital output	BIT <i>x</i>
SP.DOVER# <i>n</i>	Overrange digital output	BIT <i>x</i>
BATCHNG	Batching mode	OFF, AUTO, MANUAL
SP.ENABLE# <i>n</i>	Setpoint enable	ON, OFF

For setpoint commands ending with "#*n*", *n* is the setpoint number.

Table 11-9. Setpoint Serial Commands

11.1.5 Normal Mode Commands

The normal mode print commands transmit data to the serial port on demand in either setup or normal mode ([Table 11-10](#)).

Command	Description	Values
CONSNUM	Set consecutive number	0–9 999 999
UID	Set unit ID	nnnnnn
SD	Set date	MMDDYY, DDMMYY, YYMMDD, or YYDDMM ; Enter six-digit date using the year-month-day order specified for the DATEFMT parameter, using only the last two digits of the year
ST	Set time	hhmm (enter using 24-hour format)
CONTRAST	Set display contrast	0–127
SX#p	Start serial port streaming	OK or ??
EX#p	Stop serial port streaming	The port streaming parameter (EDP.STREAM#p) for the streaming port must be set to LFT or INDUST before using these commands; An EX command sent while in setup mode does not take effect until the indicator is returned to normal mode
RS	Reset system	Soft reset; Used to reset the indicator without resetting the configuration to the factory defaults
SF#n	Transmit single frame of stream	Sends a single frame from scale <i>n</i> to the streaming port
XA#1	Transmit accumulator value in displayed units	nnnnnn UU
XAP#1	Transmit accumulator value in primary units	
XAS#1	Transmit accumulator value in secondary units	
XAT#1	Transmit accumulator value in tertiary units	
XG#1	Transmit gross weight in displayed units	nnnnnn UU
XGP#1	Transmit gross weight in primary units	
XGS#1	Transmit gross weight in secondary units	
XGT#1	Transmit gross weight in tertiary units	
XN#1	Transmit net weight in displayed units	nnnnnn UU
XNP#1	Transmit net weight in primary units	
XNS#1	Transmit net weight in secondary units	
XNT#1	Transmit net weight in tertiary units	
XT#1	Transmit tare weight in displayed units	nnnnnn UU
XTP#1	Transmit tare weight in primary units	
XTS#1	Transmit tare weight in secondary units	
XTT#1	Transmit tare weight in tertiary units	
XE	Query system error conditions	nnnnn See Section 12.1.5 on page 115 for detailed information about the XE command response format

Table 11-10. Normal Mode Serial Commands

11.1.6 Batching Control Commands

The commands listed in [Table 11-11](#) provide batching control through the serial port



NOTE: The following batch control commands only apply to the 720i Batch Version Software only.

Command	Description	Values
BATSTART	Batch start	If the BATRUN digital input is active (low) or not assigned, the BATSTART command can be used to start the batch program
BATSTOP	Batch stop	Stops the batch program and turns off all associated digital outputs
BATPAUSE	Batch pause	Stops the batch program at the current step; All digital outputs set on by the current step (except for those set by concur setpoints) are set off; The BATSTRT DIGIN, BATSTART serial command or the Batch Start softkey
BATRESET	Batch reset	Stops the program and resets the batch program to the first batch step; Run the BATRESET command after making changes to the batch configuration
BATSTATUS	Batch status	Returns YYYY. X is S (stopped batch), P (paused batch) or R (running batch). YYY is the current batch setpoint number (1-32). Example responses: <ul style="list-style-type: none"> • S000 - Batch stopped at SP0 • R003 - Batch running at SP3 • P004 - Batch paused at SP4

Table 11-11. Batching Control Commands

11.1.7 Digital I/O Control Commands

The commands listed in [Table 11-12](#) provide control of digital I/O.

Command	Descriptions	Values
DON. <i>b</i> # <i>s</i>	Set digital output on (active) at bit <i>b</i> , slot <i>s</i>	—
DOFF. <i>b</i> # <i>s</i>	Set digital output off (inactive) at bit <i>b</i> , slot <i>s</i>	—
NOTE: Digital inputs and outputs are specified by bit number (b) and slot number (s).		

Table 11-12. Digital I/O Control Commands

11.1.8 Database Commands

The commands listed in [Table 11-13](#) can be used to create and maintain databases in the 720i. Except for the **db.delall** command, all of the database commands require an extension to identify the number of the database within the memory card and the slot number of the memory card.

Command	Description
DB.ALIAS. <i>n</i> # <i>x</i>	Get or set database name
DB.CLEAR. <i>n</i> # <i>x</i>	Clear database contents
DB.DATA. <i>n</i> # <i>x</i>	Get or set database contents
DB.SCHEMA. <i>n</i> # <i>x</i>	Get or set database structure
db.delall	Delete all databases and database contents
<i>n</i> represents the database number within the memory card; <i>x</i> is the slot number of the memory card; Each command must be terminated with a carriage return character (<CR>, ASCII 13)	

Table 11-13. Database Commands

db.alias

The **db.alias** command is used to get or set the alias used by *PCEE* programs to reference the specified database. Each database alias must be unique among all databases and adhere to the following rules: 8 character maximum which must begin with an alpha character or an underscore and can only contain A–Z, a–z, 0–9 or an underscore (_).

Example: The following command assigns an alias of TRUCKS_2 to the first database on the memory card installed in slot 2:

```
DB.ALIAS.1#2=TRUCKS_2<CR>
```

Sending the **db.alias** command alone, without assigned data, returns the current database alias.

db.clear

To clear the contents of a database, send the following command:

```
DB.CLEAR.n#x<CR>
```

Where:

n is the database number within the memory card

x is the slot number of the memory card (0 is the onboard memory)

The 720i responds with **OK<CR>** if the command is successful, **??<CR>** if unsuccessful.

db.data

The **db.data** command can be used to send data to or retrieve data from the 720i.

Data can be sent to the indicator using the following command:

```
DB.DATA.n#x = data{ | }<CR>
```

Where:

n is the database number within the memory card

x is the slot number of the memory card (0 is the onboard memory)

data represents a single cell of a row of data

{ | } is a pipe character (ASCII 124), used to delimit cell data. If the data being sent is not the last cell of the row, append the pipe character to the data to indicate that more data is coming for that particular row. If the data being sent is the last cell of the row, do not append the pipe character.

If the command is accepted, the 720i responds with **OK<CR>**; if not, it responds with **??<CR>**.

Example: The following commands place the data in [Table 11-14](#) into the first database in the onboard memory:

```
DB.DATA.1#0=this|<CR>
```

```
DB.DATA.1#0=is|<CR>
```

```
DB.DATA.1#0=a|<CR>
```

```
DB.DATA.1#0=test<CR>
```

```
DB.DATA.1#0=aaa|<CR>
```

```
DB.DATA.1#0=bbb|<CR>
```

```
DB.DATA.1#0=ccc|<CR>
```

```
DB.DATA.1#0=ddd<CR>
```

Record	Cell			
	1	2	3	4
first	this	is	a	test
second	aaa	bbb	ccc	ddd

Table 11-14. Sample Database Contents

Sending the **db.data** command alone, without assigned data, returns the database contents:

```
DB.DATA.n#x<CR>
```

The 720i responds with the entire contents of the database. Returned data is cell-delimited with the pipe character (ASCII 124) and row-delimited with carriage returns (ASCII 13).

For example, the following command could be used to return the contents of database 1 in the onboard memory:

```
DB.DATA.1#0<CR>
```

If the database contents are the records in [Table 11-14](#), the indicator responds with the following data, using pipe characters and carriage returns to delimit the database cells and rows, respectively:

```
this|is|a|test<CR>aaa|bbb|ccc|ddd<CR>
```



NOTE: *There is no end of database notification at the end of the db.data command transmission. Use a receive time-out to determine command completion. The time-out value varies based on baud rate.*

Determine the number of records currently in the database both prior to and after sending the **db.data** command to verify that the correct number of records are received. The number of records can be determined with the **db.schema** command.



NOTE: *The 62K of onboard (slot 0) memory can be allocated to up to eight auxiliary databases. However, the size of one database may limit the size and number of other databases.*

db.schema

The **db.schema** command is used to get or set the structure of a database.

DB.SCHEMA.n#x<CR>

The 720i responds to the command above by returning the following:

<Max Records>,<Current Record Count>,
<Column Name>,<Data Type>,<Data Size>,...<CR>

The <Column Name>, <Data Type>, and <Data Size> elements repeat for each column in the database.

The <Column Name> follows the rules for alias names: 8 character maximum; must begin with an alpha character or an underscore; can only contain A–Z, a–z, 0–9, or an underscore (_).

The <Data Type> is represented by a numeric field:

Value	Type
1	Byte
2	Short (16-bit integer)
3	Long (32-bit integer)
4	Single (32-bit floating point)
5	Double (64-bit floating point)
6	Fixed string
7	Variable string
8	Date and time

Table 11-15. Data Type Field Codes

The <Data Size> value must match the data type. A range of data size values is allowed only for the string data types:

Size	Value
Byte	1
Short	2
Long	4
Single	4
Double	8
Fixed string	1–255
Variable string	1–255
Date and time	8

Table 11-16. Data Size Field Codes

The **db.schema** command can also be used to modify the schema, but only when the indicator is in setup mode and only if the database does not contain data.

11.1.9 Advance Mode EDP Commands

See [Table 11-17](#) for the EDP commands for the configuration of Advance Mode.

Command	Value
DAY.END	000000–235959
DAY.START	000000–235959
SHIFT.1.END	000000–235959
SHIFT.1.START	000000–235959
SHIFT.2.END	000000–235959
SHIFT.2.START	000000–235959
SHIFT.3.END	000000–235959
SHIFT.3.START	000000–235959
PROMPT.COMMENTS	ON/OFF
PROMPT.DELIVERY.NUM	ON/OFF
PROMPT.DELIVERY.WGT	ON/OFF
PROMPT.CUSTOMER	ON/OFF
PROMPT.MATERIAL	ON/OFF
PROMPT.REPRINT	ON/OFF
PROMPT.SOURCE	ON/OFF
PROMPT.VEHICLE	ON/OFF
PROMPT.PRINT	ON/PROMPT/OFF
SERIAL.NUMBER	0–9999999

Table 11-17. Advance Mode EDP Commands



NOTE: The 720i must see six digits of data for the time values in the first 8 parameters. If the 720i does not detect 000000, the 720i responds with ??.

12.0 Appendix

This section provides an overview of additional 720i Programmable HMI Indicator/Controller instructions.

12.1 Troubleshooting

Table 12-1 lists general troubleshooting tips for various hardware and software error conditions. See the following pages for additional information about specific diagnostic tools.

Symptom	Cause/Remedy
Indicator does not power up	Possible blown fuse or bad power supply; replacement of fuses shall only be completed by qualified service personnel Check all voltages on CPU board; Power supply should output both +6 V and –6 V levels to the CPU board (Figure 3-2 on page 18); If power supply appears bad, check the small glass fuse (2.5 A, 5 x 20 mm) on the power supply board
Front panel power indicator blinking (Z)	Power supply overloaded; Check for shorts in A/D card regulators or in the DC-to-DC converter of installed analog output or pulse input cards
Tare and truck data pointers are corrupt, Tare storage is corrupt error messages at startup	Possible dead battery; Perform configuration reset then check for low battery warning on display; If battery is low, replace battery, perform another configuration reset then reload files
ERROR message in weight display	Excitation voltage too low or off
Dashes in weight display	Overrange or underrange scale condition, check scale; For out-of-range conditions in total scale display, check all scale inputs for positive weight values
Display reads 0.000000	Scale not updating; Check for bad option card hanging the bus
Serial port not responding	Possible configuration error; For command input, ensure port INPUT parameter is set to CMD
A/D scale out of range	Check source scale for proper mechanical operation; Check load cell and cable connection; Possible bad load cell: check indicator operation with load cell simulator
Serial scale out of range	Check source scale for proper mechanical operation; Check cable connection; Possible format mismatch between serial scale and 720i: Check SFMT specification under SERIAL menu
Option x Error	Field bus card (Profibus, DeviceNet, or Remote I/O) in slot x failed to initialize
Option card failure	Possible defective card or slot
Option card hardware diagnostic error	Required option card not found (Section 12.1.1)

Table 12-1. Basic Troubleshooting



NOTE: Always save copies of the indicator configuration, calibration, Revolution files on a local PC so that these are available when a software reload or upgrade is required.

12.1.1 Option Card Diagnostic Errors

Option cards are detected by the 720i at power-up. If the current indicator configuration requires an option card but that card is not detected at power-up, an error similar to the following is displayed:

HARDWARE CRITICAL TO PROPER OPERATION
WITH CURRENT CONFIGURATION
CANNOT BE FOUND

A second screen displays.

SERIAL PORT 7 SLOT 2 CHANNEL 2

Then finally a third screen:

INSTALL HARDWARE OR RECONFIGURE

To recover from this error, do the following:

- If the option is required, ensure that the card is properly seated in its slot and cycle the power; If the card is still not recognized, replace the card
- Enter setup mode and reconfigure to eliminate the requirement for the option
- Go to the **VERSION** menu and use the **Reset Config** softkey (or RESETCONFIGURATION command) to perform a configuration reset; Configuration reset returns all configuration values to their factory defaults

See Section 12.1.2 on page 114, for details on using the HARDWARE serial command to verify installed cards are recognized.

12.1.2 Using the HARDWARE Command

The HARDWARE serial command can be issued to verify that all installed cards are recognized by the system.

HARDWARE returns a string of card type codes. The first digit represents the single-channel A/D of the 720i; the second digit represents the card, if any, installed in the expansion slot: HARDWARE=3,4

Table 12-2 lists the card codes returned by the HARDWARE command.

Code	Card Type
0	No card installed
1	Dual-Channel Serial Expansion Card
3	Single-Channel A/D
4	Analog Output Card
5	24-Channel Digital I/O Expansion Card
9	DeviceNet Card
10	Profibus Card
11	EtherNet/IP Card
12	Remote I/O Card
14	Custom Card
16	ControlNet Card

NOTE: Code 11 is returned only by the EtherNet/IP card. The standard 10M/100Mbps Ethernet card does not return a card type code. The standard Ethernet card returns a value of 0 on the HARDWARE command.

Table 12-2. HARDWARE Command Option Card Codes

If an installed card is not recognized (HARDWARE command returns a code of **0** for that slot), ensure that the card is seated properly. Reinstall the card. If necessary, cycle the indicator power to read the configuration again.

12.1.3 Diagnostic Boot Procedure

If a persistent error occurs that cannot be cleared with the RESETCONFIGURATION command, perform the following diagnostic boot procedure.

1. Disconnect power to the 720i.
2. Connect the serial port of a PC with Revolution installed to port 2 of the 720i.
3. Open the indicator enclosure and place a jumper across the boot mode pins (Figure 3-2 on page 18).
4. Power up the 720i. The indicator stalls at the diagnostic monitor.
5. Start Revolution and enter monitor mode then type BOOT.
6. Place jumper J9 across both pins to enable setup mode.
7. Press **MENU** then select **Configuration** to enter setup mode.
8. Remove the jumper from SW1.
9. From monitor mode, enter the RESETCONFIGURATION command.

12.1.4 Onboard Diagnostic LEDs

The 720i CPU board provides a number of LEDs that may be useful for monitoring or diagnosing communications or other functions.

LED	Function
HB1	CPU heartbeat. Off in boot monitor mode; blinks when processor is running
LED 1	Port 2 communications
LED 2	Port 3 (DDM)
LED 3	--
LED 4	Port 4 communications
IO1-IO8	Monitor active digital I/O

Table 12-3. CPU Board LEDs

12.1.5 Using the XE Serial Command

The XE serial command can be used to remotely query the 720i for the error conditions on the front panel.

The XE command returns a decimal number representing existing error conditions. For multi-scale applications, the value returned by the XE command represents all error conditions, if any, present on all configured scales.

If more than one error condition exists, the number returned is the sum of the values representing the error conditions (Table 12-4). For example, if both a tare error (TAREERR, 65536) and a truck database checksum error (ETRUCKERR, 8192) have occurred, the XE command returns the value 73728, representing the sum of those two error conditions.

Error Code	Value	Description
VIRGERR	1	Virgin error
PARMCHKERR	2	Configuration checksum error
LOADCHKERR	4	Calibration checksum error
PRINTCHKERR	8	Print format checksum error
ENVRAMERR	16	General NVRAM error
ENVCRC1ERR	32	Setpoint NVRAM data error
ENVCRC2ERR	64	
ENVCRC3ERR	128	
ENVCRC4ERR	256	
ENVCRC5ERR	512	
ENVCRC6ERR	1024	
ENVCRC7ERR	2056	
ENVCRC8ERR	4096	
ETRUCKERR	8192	Truck database checksum error
GRAVERR	16384	Gravity calibration error
ADPHYSICALERR	32768	A/D physical error
TAREERR	65536	Tare checksum error
STRINGERR	262144	String program error
POWER_FAIL	524288	Power failure
RTCERR	1048576	Real time clock error

Table 12-4. Error Codes Returned on XE Command

12.2 Regulatory Mode Functions

The function of the front panel **TARE** and **ZERO** keys depends on the value specified for the REGULAT parameter on the **FEATURE** menu. Table 12-5 describes the function of these keys for the NTEP, CANADA, OIML, and NONE regulatory modes. **TARE** and **ZERO** key functions are configurable when the REGULAT mode is set to INDUST (Table 12-6).

REGULAT Parameter Value	Weight on Scale	Tare in System	Front Panel Key Function	
			TARE	ZERO
NTEP	Zero or negative	No	No action	ZERO
		Yes	CLEAR TARE	
	Positive	No	TARE	
		Yes	TARE	
CANADA	Zero or negative	No	No action	ZERO
		Yes	CLEAR TARE	
	Positive	No	TARE	
		Yes	No action	
OIML	Zero or negative	No	No action	ZERO
		Yes	CLEAR TARE	ZERO and CLEAR TARE
	Positive	No	TARE	ZERO
		Yes	TARE	ZERO and CLEAR TARE if weight is within ZRANGE; No action if weight is outside of ZRANGE
NONE	Zero or negative	No	TARE	ZERO
		Yes	CLEAR TARE	
	Positive	No	TARE	
		Yes	CLEAR TARE	

Table 12-5. TARE and ZERO Key Functions for REGULAT Parameter Settings

Table 12-6 lists the subparameters available when configuring a scale using INDUST mode. The table includes the default values of the INDUST subparameters and the effective (not configurable) values used by the NTEP, CANADA, OIML, and NONE regulatory modes.

REGULAT / INDUST Parameter		REGULAT Mode				
Parameter Name	Text Prompt	INDUST	NTEP	CANADA	OIML	NONE
SNPSHOT	Display or Scale weight source	DISPLAY	DISPLAY	DISPLAY	DISPLAY	SCALE
HTARE	Allow tare in display hold	NO	NO	NO	NO	YES
ZTARE	Remove tare on ZERO	NO	NO	NO	YES	NO
KTARE	Always allow keyed tare	YES	YES	NO	YES	YES
MTARE	Multiple tare action	REPLACE	REPLACE	NOTHING	REPLACE	REMOVE
NTARE	Allow negative tare	NO	NO	NO	NO	YES
CTARE	Allow CLEAR key to clear tare/accumulator	YES	YES	NO	NO	YES
PRTMOT	Allow print while in motion	NO	NO	NO	NO	YES
PRTPT	Add PT to keyed tare print	NO	NO	YES	YES	NO
PRTHLD	Print during display hold	NO	NO	NO	NO	YES
HLDWGH	Allow weigh during display hold	NO	NO	NO	NO	YES
MOTWGH	Allow weightment in motion	NO	NO	NO	NO	NO
OVRBASE	Zero base for overload calculation	CALIB ZERO	CALIB ZERO	CALIB ZERO	SCALE ZERO	CALIB ZERO

Table 12-6. REGULAT / INDUST Mode Parameters, Comparison with Effective Values of Other Modes

12.3 Serial Scale Interface

Serial port 4 or the expansion port can be configured for serial scale input. The serial scale function allows other scale indicators to send gross, net, or tare weight data to the 720i. Once a serial port has been configured to accept scale data, the data format can be customized to match the data stream sent by that indicator.



NOTE: *The serial scale will not track an analog output offset of 4 mA. The serial scale tracks 0-20 mA but not 4-20 mA.*

To configure a serial scale, do the following:

1. Under the **SERIAL** menu, set the INPUT parameter for the selected port to SCALE (legal-for-trade serial scale) or IND SC (industrial serial scale).
2. Return to the **SCALES** menu. Under CONFIG, drop down and use the **Right** or **Left** navigation key to select the serial port (PORT 4 or PORT 7).
3. Use Revolution to edit the SFMT parameter to match the format sent by the serial scale.

The default serial scale format is:

```
<2><P><W7.><U><M><S><CR><LF>
```

where:

<2>	STX character
<P>	Polarity
<W7.>	Seven characters of net data with decimal point
<M>	Mode
<U>	Units
<S>	Status
<CR>	Carriage return
<LF>	Line feed



NOTE: *Industrial serial scales (INDUST) do not require the <M>, <U>, and <S> identifiers. However, the units and number of decimal places must be specified. Units can be selected from the FORMAT menu; decimal places should be indicated on the w-spec identifier. For example, a seven-digit weight requiring two decimal places should be specified as <W7.2> rather than <W7.>.*

See [Section 12.5 on page 119](#) for more information about stream formatting and format identifiers.

12.4 Local/Remote Operation

For truck scale and similar applications, local/remote support provides function equivalent to that of a legal-for-trade remote display with keypad. Scale data from the local indicator is also displayed at the remote unit, and keypad input from the remote allows transactions to be initiated from either the local or remote unit.

To configure for local/remote operation, first set up the local unit (including truck mode and database information, as required) as an A/D scale. Once the local unit scale has been configured, use the **SERIAL** menu, serial commands or Revolution to set the serial parameters for local/remote operation (Table 12-7).

Serial Configuration Parameter	Local Unit		Remote Unit	
	Parameter Value	Function	Parameter Value	Function
EDP.INPUT# <i>p</i>	CMD	Enables receipt of commands from the remote unit keypad	SCALE	Configures the remote unit as a serial scale receiving weight data from the local unit
EDP.STREAM# <i>p</i>	LFT	Streams local unit weight data to the remote unit	KEYPAD	Streams commands from the remote unit keypad back to the local unit
EDP.BAUD# <i>p</i>	115200 preferred; local and remote values must match			
EDP.ECHO# <i>p</i>	OFF	—	OFF	—
EDP.RESPONSE# <i>p</i>	ON	—	ON	—
<i>In the listed serial commands, p represents the serial port number. For units without a serial expansion card, Port 4 is recommended for local/remote configuration.</i>				

Table 12-7. Local/Remote Configuration Parameters

Remote unit only – Once the serial parameters are set for the remote unit, return to the **SCALES** menu to finish configuring the remote unit as a serial scale. Under CONFIG, drop down and use the **Right** or **Left** navigation key to select the serial port (PORT 4 or PORT 7) used to receive weight data from the local unit (Section 4.1.3 on page 33).

12.5 Custom Stream Formatting

Each port can be independently configured to stream a default frame format or can be customized to stream a user-defined format. Custom formatting is very similar to the standard print formatting described in [Section 7.0 on page 65](#).

[Table 12-8](#) lists the format identifiers used to configure a custom stream format.

Format Identifier	Defined By	Description
<P[G N T]>	STR.POS#1 STR.NEG#1	Polarity; Specifies positive or negative polarity for the current or specified (Gross/Net/Tare) weight on the source scale; Possible values are SPACE, NONE, + (for STR.POS#1) or - (for STR.NEG#1)
<U[P S T]>	STR.PRI#1 STR.SEC#1 STR.TER#1	Units; Specifies primary, secondary, or tertiary units for the current or specified weight on the source scale; Does not read the units which are set for in configuration; Units are not inserted into the stream NOTE: Unit output can only be changed by receiving an EDP command through Revolution or similar software.
<M[G N T]>	STR.GROSS#1 STR.NET#1 STR.TARE#1	Mode; Specifies gross, net, or tare weight for the current or specified weight on the source scale
<S>	STR.MOTION#1 STR.RANGE#1 STR.OK#1 STR.INVALID#1	Status for the source scale; Default values and meanings for each status: STR.MOTION#1 M In motion STR.RANGE#1 O Out of range STR.OK#1 <space> OK STR.ZERO#1 Z COZ
<B [-]n,...>	See descriptions below	Bit fields; Comma-separated sequence of bit field specifiers; Must be exactly 8-bits; Minus sign ([-]) inverts the bit
B0	—	Always 0
B1	—	Always 1
B2	Configuration	=1 if even parity
B3	Dynamic	=1 if MODE=NET
B4	Dynamic	=1 if COZ
B5	Dynamic	=1 if standstill
B6	Dynamic	=1 if gross negative
B7	Dynamic	=1 if out of range
B8	Dynamic	=1 if secondary/tertiary
B9	Dynamic	=1 if tare in system
B10	Dynamic	=1 if tare is keyed
B11	Dynamic	=00 if MODE=GROSS =01 if MODE=NET =10 if MODE=TARE =11 (not used)
B12	Dynamic	=00 if UNITS=PRIMARY =01 if UNITS=SECONDARY =10 if UNITS=TERTIARY =11 (not used)
B13	Configuration	=00 (not used) =01 if current DSPDIV=1 =10 if current DSPDIV=2 =11 if current DSPDIV=5
B14	Configuration	=00 (not used) =01 if primary DSPDIV=1 =10 if primary DSPDIV=2 =11 if primary DSPDIV=5

Table 12-8. Custom Stream Format Identifiers

Format Identifier	Defined By	Description
B15	Configuration	=00 (<i>not used</i>) =01 if secondary DSPDIV=1 =10 if secondary DSPDIV=2 =11 if secondary DSPDIV=5
B16	Configuration	=00 (<i>not used</i>) =01 if tertiary DSPDIV=1 =10 if tertiary DSPDIV=2 =11 if tertiary DSPDIV=5
B17	Configuration	=000 if current DECPNT=8888800 =001 if current DECPNT=8888880 =010 if current DECPNT=8888888 =011 if current DECPNT=888888.8 =100 if current DECPNT=88888.88 =101 if current DECPNT=8888.888 =110 if current DECPNT=888.8888 =111 if current DECPNT=88.88888
B18	Configuration	=000 if primary DECPNT=8888800 =001 if primary DECPNT=8888880 =010 if primary DECPNT=8888888 =011 if primary DECPNT=888888.8 =100 if primary DECPNT=88888.88 =101 if primary DECPNT=8888.888 =110 if primary DECPNT=888.8888 =111 if primary DECPNT=88.88888
B19	Configuration	=000 if secondary DECPNT=8888800 =001 if secondary DECPNT=8888880 =010 if secondary DECPNT=8888888 =011 if secondary DECPNT=888888.8 =100 if secondary DECPNT=88888.88 =101 if secondary DECPNT=8888.888 =110 if secondary DECPNT=888.8888 =111 if secondary DECPNT=88.88888
B20	Configuration	=000 if tertiary DECPNT=8888800 =001 if tertiary DECPNT=8888880 =010 if tertiary DECPNT=8888888 =011 if tertiary DECPNT=888888.8 =100 if tertiary DECPNT=88888.88 =101 if tertiary DECPNT=8888.888 =110 if tertiary DECPNT=888.8888 =111 if tertiary DECPNT=88.88888
< <i>wspec</i> [-] [0] <i>digit</i> [.][.] <i>digit</i> >	Scale weight	Weight for the source scale. <i>wspec</i> is defined as follows: <i>wspec</i> indicates whether the weight is the current displayed weight (W, w), gross (G, g), net (N, n), or tare (T, t) weight; Upper-case letters specify right-justified weights; lower-case are left-justified; Optional /P, /S, or /T suffixes can be added before the ending delimiter (>) to specify weight display in primary (/P), secondary (/S), or tertiary (/T) units; [-] Enter a minus sign (-) to include sign for negative values; [0] Enter a zero (0) to display leading zeroes; <i>digit</i> [.][.] <i>digit</i> The first digit indicates the field width in characters; Decimal point only indicates floating decimal; decimal point with following digit indicates fixed decimal with <i>n</i> digits to the right of the decimal; Two consecutive decimals send the decimal point even if it falls at the end of the transmitted weight field
<CR>	—	Carriage return
<LF>	—	Line feed

Table 12-8. Custom Stream Format Identifiers (Continued)

12.6 Data Formats

For data format information, see the following information:

12.6.1 Continuous Output Serial Data Format

If continuous transmission is configured for a serial port (STREAM parameter set to LFT or INDUST on the **SERIAL** menu), the 720i sends data using the Consolidated Controls serial data format (Figure 12-1).



NOTE: Unit output can only be changed by receiving an EDP command through Revolution or similar software.

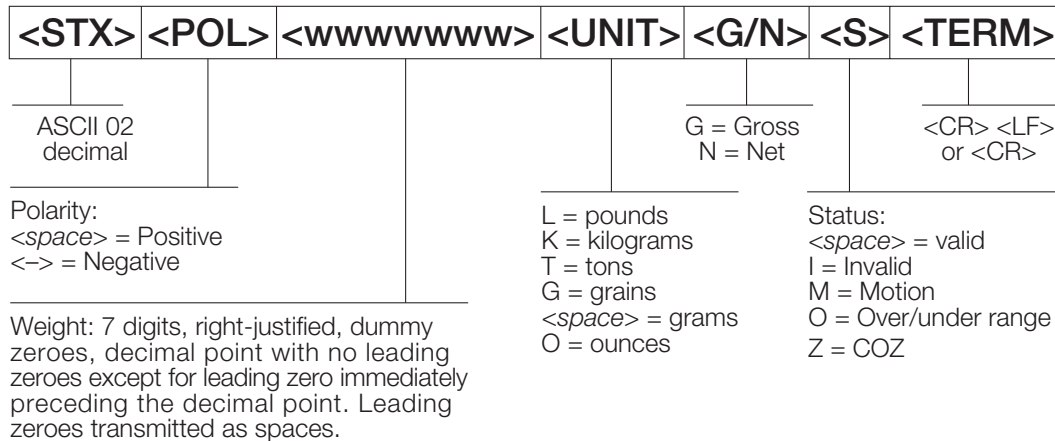

Figure 12-1. Continuous Output Serial Data Format

12.6.2 Demand Output Serial Data Format

When demand mode is configured for the serial port (STREAM parameter set to OFF), the 720i uses a data string formatted for a basic ticket printout. The particular ticket format printed depends on the indicator configuration.

The ticket can be customized to work with a wide variety of printers, scoreboard displays, and other remote equipment. See [Section 7.0 on page 65](#) for more information on custom print formats.

12.6.3 RS-485 Data Formats

Four-wire RS-485 communications is supported on the "A" ports of installed serial expansion card.

The RS-485 software protocol is enabled when assigned a non-zero address to the indicator. Valid RS-485 addresses must be in the range 1–255; the address is specified on the ADDRESS parameter on the **SERIAL** menu.

All remote commands are initiated using the data format (Figure 12-2).

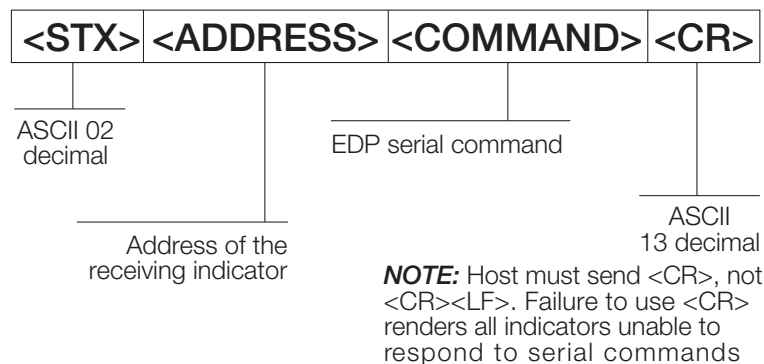

Figure 12-2. RS-485 Send Data Format

If the initiating device address matches the port address of an 720i on the RS-485 network, that indicator responds. For example, with demand outputs, or in response to a KPRINT command, the responding indicator uses the format (Figure 12-3).

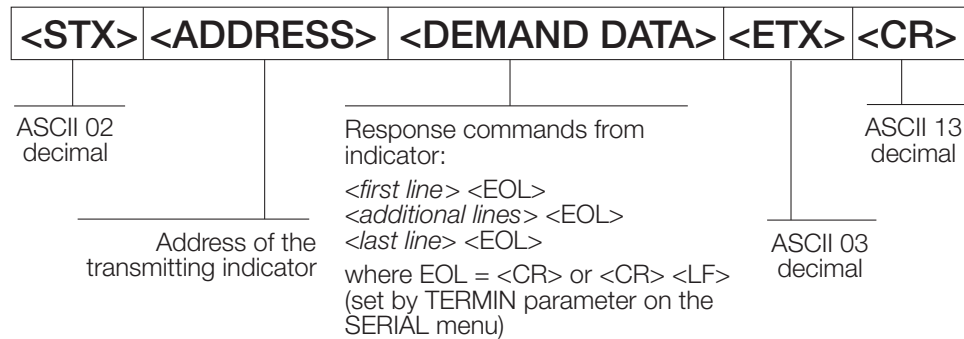

Figure 12-3. RS-485 Respond Data Format

Example: To send the KPRINT command from an ASCII terminal to an indicator at address 65 (decimal) on the RS-485 network (Figure 12-2 on page 121).

- The keyboard equivalent for the start-of-text (STX) character is CONTROL-B
- The indicator address (65) is represented by an upper case "A"
- The carriage return (CR) character is generated by pressing the **Enter** key

Therefore, to send the KPRINT command to the indicator at address 65, enter the following at the terminal: CONTROL-B, A, K, P, R, I, N, T, **ENTER**.

The indicator responds with the format contained in Figure 12-3:

```
<STX> A SCALE #1 <EOL>
GROSS 1699 LB <EOL>
01/14/2008 10:05 AM <EOL>
<ETX> <CR>
```

12.7 Digital Filtering

Standard digital filtering uses mathematical averaging to eliminate the variant digital readings that the A/D converter sends periodically because of external vibration. Digital filtering does not affect the indicator measurement rate, but does affect the settling time. The selections from 1 to 256 reflect the number of readings averaged per update period. When a reading is encountered that is outside a predetermined band, the averaging is overridden, and the display jumps directly to the new value.

DIGFLTx Parameters

The first three digital filtering parameters, DIGFLT1, DIGFLT2, and DIGFLT3, are configurable filter stages that control the effect of a single A/D reading on the displayed weight. The value assigned to each parameter sets the number of readings received from the preceding filter stage before averaging.

A rolling average is passed to successive filters for an overall filtering effect that is effectively a weighted average of the product of the values assigned to the filter stages ($DIGFLT1 \times DIGFLT2 \times DIGFLT3$) within a time frame corresponding to the sum of the values ($DIGFLT1 + DIGFLT2 + DIGFLT3$).

Setting the filters to 1 effectively disables digital filtering.

RATTLETRAP® Filtering

RATTLETRAP digital filtering (RATTRAP parameter set ON) uses a vibration-dampening algorithm to provide a combination of the best features of analog and digital filtering. The RATTLETRAP algorithm evaluates the frequency of a repeating vibration then derives a composite displayed weight equal to the actual weight on the scale less the vibration-induced flaws.

It is particularly effective for eliminating vibration effects or mechanical interference from nearby machinery. Using RATTLETRAP filtering can eliminate much more mechanical vibration than standard digital filtering but usually increase settling time over standard digital filtering.

DFSENS and DFTHR Parameters

The digital filter can be used by itself to eliminate vibration effects but heavy filtering also increases settling time.

The DFSENS (digital filter sensitivity) and DFTHR (digital filter threshold) parameters can be used to temporarily override filter averaging and improve settling time:

- DFSENS specifies the number of consecutive scale readings that must fall outside the filter threshold (DFTHR) before digital filtering is suspended
- DFTHR sets a threshold value, in display divisions; When a specified number of consecutive scale readings (DFSENS) fall outside of this threshold, digital filtering is suspended; Set DFTHR to NONE to turn off the filter override

Setting the Digital Filter Parameters

Fine-tuning the digital filter parameters greatly improves indicator performance in heavy-vibration environments.

Use the following procedure to determine vibration effects on the scale and optimize the digital filtering configuration.

1. In setup mode, set the digital filter parameters (DIGFLT1–DIGFLT3) to 1. Set DFTHR to NONE. Return indicator to normal mode.
2. Remove all weight from the scale then watch the indicator display to determine the magnitude of vibration effects on the scale. Record the weight below which all but a few readings fall. This value is used to calculate the DFTHR parameter value in [Step 4](#).

Example: If a heavy-capacity scale (10000 x 5 lb) produces vibration-related readings of up to 50 lb, with occasional spikes to 75 lb, record 50 lb as the threshold weight value.

3. Place the indicator in setup mode and set the DIGFLT x parameters to eliminate the vibration effects on the scale. (Leave DFTHR set to NONE.) Find the lowest effective value for the DIGFLT x parameters.
4. Calculate the DFTHR parameter value by converting the weight value recorded in [Step 2](#) to display divisions:

$$\text{threshold_weight_value} / \text{display_divisions}$$

In the example in Step 2, with a threshold weight value of 50 lb and a display divisions value of 5 lb: $50 / 5 = 10$. DFTHR should be set to 10D for this example.

5. Finally, set the DFSENS parameter high enough to ignore transient peaks. Longer transients (typically caused by lower vibration frequencies) cause more consecutive out-of-band readings, so DFSENS should be set higher to counter low frequency transients.

Reconfigure as necessary to find the lowest effective value for the DFSENS parameter.

12.8 Conversion Factors for Secondary Units

The 720i has the capability to mathematically convert a weight into many different types of units and instantly display those results with a press of the **UNITS** key.

Secondary and tertiary units can be specified on the **FORMAT** menu using the SECNDR and TERTIA parameters, or by using serial commands.

- To configure secondary or tertiary units using the front panel menus, use the [Table 11-9 on page 106](#) to find the conversion multiplier for the MULT parameter

Example: If the primary unit is pounds and the secondary unit is short tons, set the MULT parameter to 0.000500.

- To configure secondary or tertiary units using serial commands, use the [Table 11-9 on page 106](#) to find the conversion multiplier for the SC.SEC.MULT or SC.TER.MULT command; For example, if the primary unit is pounds and the secondary unit is short tons, send the serial command SC.SEC.MULT= 0.0005<CR> to set the multiplier for the secondary units



NOTE: Ensure that the secondary decimal point position is set appropriately for the scale capacity in the secondary units. If the converted value requires more digits than are available, the indicator displays an overflow message (OVERFL).

Example: If the primary units are short tons, secondary units are pounds, and the secondary decimal point is set to 8888.888, the indicator overflows if 5 tons or more are applied to the scale. With 5 tons applied, and a conversion factor of 2000, the secondary units display needs five digits to the left of the decimal point to display the 10000 lb secondary units value.

Primary Unit	x Multiplier	Secondary/ Tertiary Unit
grains	0.064799	grams
	0.002286	ounces
	0.000143	pounds
	0.000065	kilograms
	0.002083	troy ounces
	0.000174	troy pounds
ounces	437.500	grains
	28.3495	grams
	0.06250	pounds
	0.02835	kilograms
	0.911458	troy ounces
	0.075955	troy pounds
pounds	7000.00	grains
	453.592	grams
	16.0000	ounces
	0.453592	kilograms
	14.58333	troy ounces
	1.215278	troy pounds
	0.000500	short tons
	0.000446	long tons
	0.000453	metric tons
grams	15.4324	grains
	0.035274	ounces
	0.002205	pounds
	0.001000	kilograms
	0.032151	troy ounces
	0.002679	troy pounds

Primary Unit	x Multiplier	Secondary/ Tertiary Unit
kilograms	15432.4	grains
	35.2740	ounces
	1000.00	grams
	2.20462	pounds
	32.15075	troy ounces
	2.679229	troy pounds
	0.001102	short tons
	0.000984	long tons
	0.001000	metric tons
	short tons	2000.00
907.185		kilograms
0.892857		long tons
0.907185		metric tons
metric tons	2204.62	pounds
	1000.00	kilograms
	1.10231	short tons
	0.984207	long tons
long tons	2240.00	pounds
	1016.05	kilograms
	1.12000	short tons
	1.01605	metric tons
troy ounces	480	grains
	31.10348	grams
	0.031103	kilograms
	1.09714	ounces
	0.068571	pounds
	0.083333	troy pounds
troy pounds	5760	grains
	373.2417	grams
	0.373242	kilograms
	13.16571	ounces
	0.822857	pounds
	12	troy ounces

Table 12-9. Conversion Factors

12.9 Audit Trail Support

Audit trail support provides tracking information for configuration and calibration events. To prevent potential misuse, all configuration and calibration changes are counted as change events.

Use Revolution to display audit trail information. The audit trail display includes the legally relevant (LR) version number (software version for the code that provides audit trail information), a calibration count and, if REGULAT=NTEP, a configuration count. The exact format of the information depends on the regulatory agency specified for the REGULAT (**FEATURE** menu) parameter.

Audit trail information can be printed from Revolution or by sending the DUMPAUDIT serial command.

By pressing the **MENU** key, the **Audit Trail** menu is bold. Pressing the **Enter** key displays the LR software number and the current audit trail counter. When done, press **Enter** to return to weighing mode.

For NTEP and Measure Canada modes, there are two numbers displayed; Configs and Calibs. The Configs number tracks changes to the legally relevant configuration parameter changes. The Calibs number tracks changes to the scale calibration.

In OIML mode, there is only one number displayed; Audit Trail. The Audit trail number is incremented for legally relevant configuration parameter changes and all calibration changes. The last date the scale was calibrated is also displayed.

12.10 Display Module Configuration

The detached display module (DDM) used by both the universal and panel models of the 720i communicates with the CPU board (host) using Port 3 (connector J4). To verify active communications between the host and the display, the 720i provides a HEARTBEAT parameter (**FEATURE** menu). This parameter, when used with the HB1:I parameter in the display module, provides notification of communications failure between the host and the display module.

If HEARTBEAT is specified, the display module input heartbeat (HB1:I parameter) must also be set, typically to a value slightly longer than the host HEARTBEAT parameter. For example, set HEARTBEAT to 1.5 seconds, and HB1:I=2.0. With these values set, the host should send a heartbeat packet to the display module every 1.5 seconds; if the display module does not receive an incoming heartbeat with 2.0 seconds, an error message (**Host Communication Error**) displays.

To view the DDM configuration display, press the **MENU** key to display the main 720i menu then press and hold the **MENU** key until the following display is shown:

Com	Baud	Parity	Bits	Stop	Output	Echo	CkSum	Mode
0	115200	N	8	1	com0	com0	off	shell
1	115200	N	8	1	com1	off	crcA	RTL
Keydev	Keymode	DspKey	HB0:I / 0		HB1: I / 0			
com1	RTL	off	0		0		2 0	
			RTL Defaults		Save & Exit		Exit	

Figure 12-4. DDM Configuration Display

To change the heartbeat value for the display module, use the **Right** navigation key to highlight the input (I) value for HB1 then use the **Up** or **Down** navigation key to adjust the value.

12.10.1 DDM Communications Ports

Com1 is a RS-422 port that provides communications with the 720i CPU board host. Com0 is a limited function RS-232 port used to write the DDM firmware.

12.11 Alibi Tracking

Alibi tracking allows a previously printed weigh ticket to be reprinted. When enabled, every transaction is stored as long as memory is available. There is 256 KB of memory reserved for storing transactions. When memory is full, it erases the first 25% of the stored transactions. The entire transaction is stored as it was sent to the printer.

The alibi function is turned on in the **FEATURE** menu. See [Figure 4-12 on page 50](#) for parameter location and [Table 4-8 on page 51](#) for description. An alibi softkey also needs to be enabled to provide operator access to the alibi records. This softkey is enabled in the **FEATURE** menu or through Revolution in the base configuration menu, under the softkey tab.



NOTE: *Alibi tracking must be turned on when in OIML mode in order to meet the legal-for-trade requirement.*

There is a unique alibi tracking number assigned for each printed transaction. This number <AN> can be printed on the ticket by adding it to the print string format ([Table 7-1 on page 65](#) and [Table 7-2 on page 67](#)). When the **Alibi** softkey is pressed, the stored transactions is displayed. The display contains the alibi ID number, date, and time. By displaying the desired ID number and pressing print, the transaction is reprinted. It prints to the same port it was originally printed.

To access and print stored printed transactions, do the following:

1. Press the **Alibi** softkey.
The first stored transaction is displayed.
2. Use the **Up/Down** navigation keys to display the next stored transaction. Pressing the **Down 100** softkey jumps ahead in increments of 100.
3. When the desired transaction is displayed, press the **Print** key to reprint this transaction.
4. When done, press **Done** to return to weighing mode.

12.12 Dimension Drawings

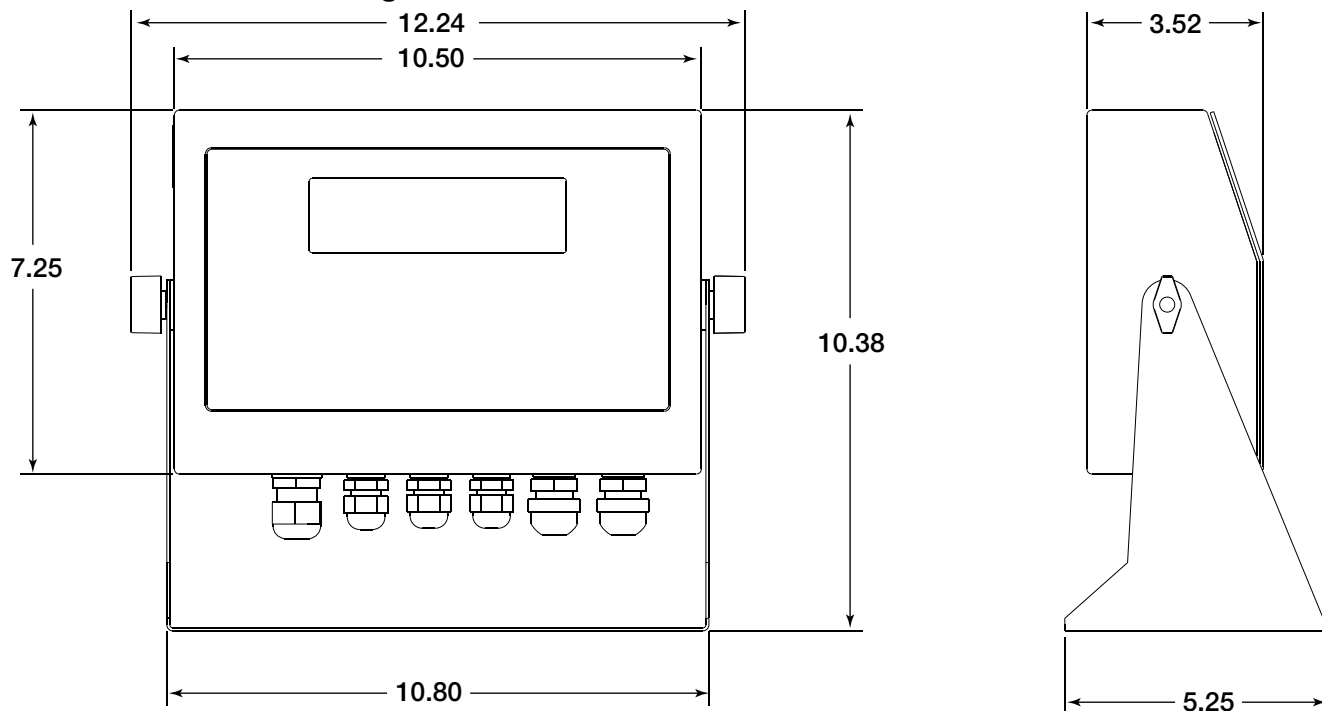

Figure 12-5. Universal Model Dimensions

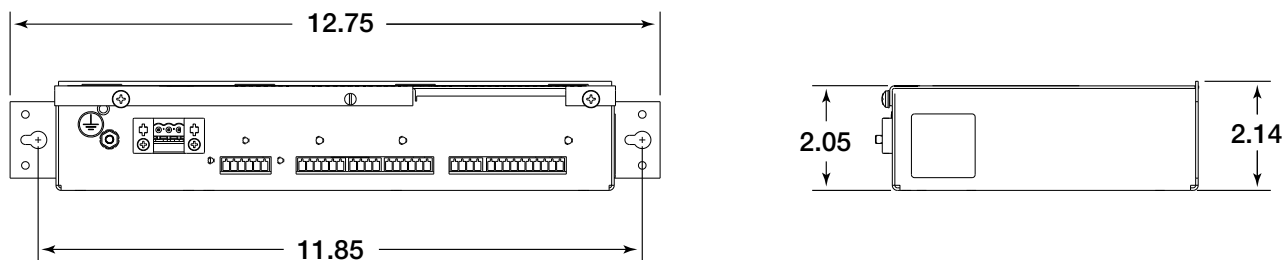
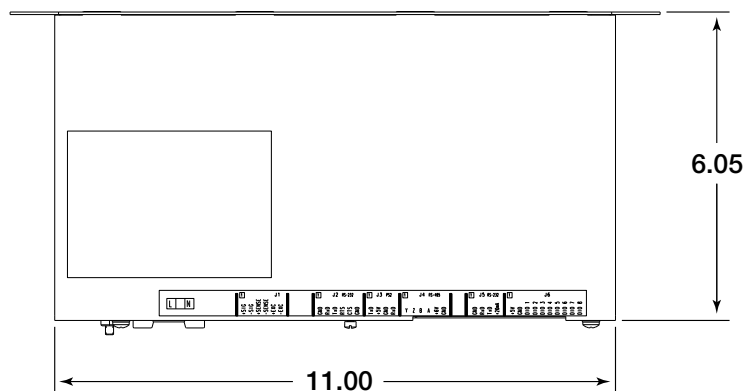

Figure 12-6. Panel Mount Controller Dimensions

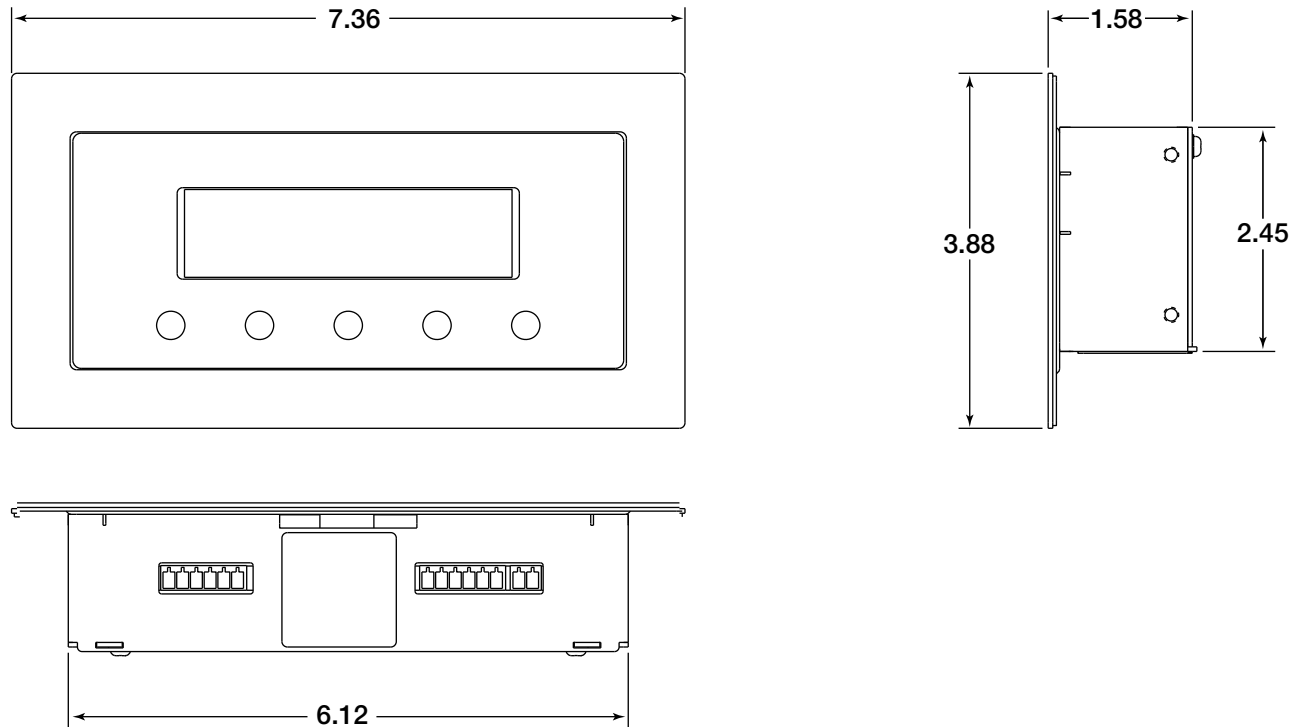

Figure 12-7. Panel Mount Display Dimensions

12.13 Printed Information

System Manuals

- 720i Installation Manual, PN 103121

Option Cards (720i/820i/920i)

- Analog Output Card Installation Instructions, PN 69089
- 24-Channel Digital I/O Expansion Card Installation Instructions, PN 69087
- Dual Channel Serial Card Instructions, PN 69090



Communications Options (520/720i/820i/920i)

- DeviceNet™ Interface Installation and Programming Manual, PN 69949
- Profibus® DP Interface Installation and Programming Manual, PN 69948
- Allen-Bradley® Remote I/O Interface Installation and Programming Manual, PN 69950
- Ethernet Communications Card Installation Instructions, PN 72117
- EtherNet/IP Communications Card Installation Instructions, PN 88537
- USB Interface Card Installation Instructions, PN 95490

White Papers

- Using Ferrite Cores to Suppress Electromagnetic Interference - For Digital Weight Indicators, PN 117085

13.0 Compliance

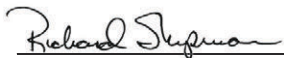
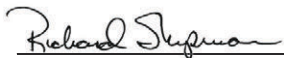
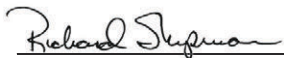
	EU DECLARATION OF CONFORMITY <i>EU-KONFORMITÄTSERKLÄRUNG</i> <i>DÉCLARATION UE DE CONFORMITÉ</i>		Rice Lake Weighing Systems 230 West Coleman Street Rice Lake, Wisconsin 54868 United States of America						
									
Type/Typ/Type: 720i series									
English	We declare under our sole responsibility that the products to which this declaration refers to, is in conformity with the following standard(s) or other regulations document(s).								
Deutsch	Wir erklären unter unserer alleinigen Verantwortung, dass die Produkte auf die sich diese Erklärung bezieht, den folgenden Normen und Regulierungsbestimmungen entsprechen.								
Francais	Nous déclarons sous notre responsabilité que les produits auxquels se rapporte la présente déclaration, sont conformes à la/aux norme/s suivante ou au/aux document/s normatif/s suivant/s.								
EU Directive	Certificates	Standards Used / Notified Body Involvement							
2014/30/EU EMC	-	EN 61326-1:2013, EN 55011:2009+A1:2010, EN 61000-6-2:2005+AC:2005							
2014/35/EU LVD	-	EN 60950-1-07:2007							
2011/65/EU RoHS	-	EN 50581:2012							
<table style="width: 100%; border: none;"> <tr> <td style="width: 50%; vertical-align: top;"> Signature: <u></u> </td> <td style="width: 50%; vertical-align: top;"> Place: <u>Rice Lake, WI USA</u> </td> </tr> <tr> <td style="vertical-align: top;"> Type Name: <u>Richard Shipman</u> </td> <td style="vertical-align: top;"> Date: <u>May 3, 2019</u> </td> </tr> <tr> <td style="vertical-align: top;"> Title: <u>Quality Manager</u> </td> <td></td> </tr> </table>				Signature: <u></u>	Place: <u>Rice Lake, WI USA</u>	Type Name: <u>Richard Shipman</u>	Date: <u>May 3, 2019</u>	Title: <u>Quality Manager</u>	
Signature: <u></u>	Place: <u>Rice Lake, WI USA</u>								
Type Name: <u>Richard Shipman</u>	Date: <u>May 3, 2019</u>								
Title: <u>Quality Manager</u>									



**UK DECLARATION
OF CONFORMITY**

Rice Lake Weighing Systems
230 West Coleman Street
Rice Lake, Wisconsin 54868
United States of America



Type: 720i series

English We declare under our sole responsibility that the products to which this declaration refers to, is in conformity with the following standard(s) or other regulations document(s).

UK Regulations	Certificates	Standards Used / Approved Body Involvement
2016/1101 Low Voltage	-	EN 60950-1-07:2007
2016/1091 EMC	-	EN 61326-1:2013, EN 55011:2009+A1:2010, EN 61000-6-2:2005+AC:2005
2012/3032 RoHS	-	EN 50581:2012

Signature: Brandi Harder

Place: Rice Lake, WI USA

Name: Brandi Harder

Date: December 30, 2021

Title: Quality Manager

14.0 Specifications

Power

Line Voltages	100–240 VAC
Frequency	50 or 60 Hz
DC Voltages	12–24 VDC LPS (Class 2) / PS2 powered
Power Consumption	25 W maximum

Excitation Voltage

10 VDC, 16 x 350Ω or 32 x 700Ω load cells	
Sense Amplifier	Differential amplifier with 4- and 6-wire sensing

Analog Signal Input Range

-10 mV→+45 mV

Analog Signal Sensitivity

0.3 μV/grad minimum at 7.5 Hz
1.0 μV/grad typical at 120 Hz (manual only)
4.0 μV/grad typical at 960 Hz (manual only)
1.0 μV/grad recommended

A/D Sample Rate

7.5–960 Hz, software selectable

Resolution

Internal	8 000 000 counts / 8 000 000 23 bit
Display	9 999 999
Wt Display Resolution	1 000 000
Input Sensitivity	10 nV per internal count
System Linearity	±0.01% of full scale
Zero Stability	±150 nV/°C, maximum
Span Stability	±3.5 ppm/°C, maximum
Input Voltage Differential	±800 mV referenced to earth ground
Input Overload	Load cell signal lines ±10 V continuous, ESD protected
Input Impedance	>35 MΩ typical
RFI/EMI Protection	Communications, signal, excitation and sense lines protected

System Linearity

±0.01% of full scale

Digital I/O

Eight channels on CPU board; optional 24-channel I/O

Communication Ports

Two ports on CPU board support up to 115 200 bps	
Port 2	Full duplex RS-232 with handshaking
Port 4	Full duplex RS-232, simplex 20 mA
Keyboard port hard wired (Scan Code 1)	
Optional dual-channel serial expansion card available	
Channel A	RS-232, RS-485, 20 mA
Channel B	RS-232, 20 mA

Display

Panel Mount	3.8 in x 1.2 in (96 x 30 mm)
Universal	5.3 in x 1.5 in (133 x 39 mm)
240 x 64 pixel, Transflective LCD with adjustable contrast	

Keys / Buttons

Universal	22-key membrane panel
Panel Mount	10-key membrane panel tactile feel
Optional keyboard connected supported	

Temperature Range

Certified	14°F to 104°F (-10°C to 40°C)
Industrial	14°F to 122°F (-10°C to 50°C)
Storage Temperature	14°F to 158°F (-10°C to 70°C)
Humidity	0 to 95% relative humidity

Weight

Universal Enclosure	9.5 lb (4.3 kg)
Panel Mount Enclosure	8.5 lb (3.9 kg)

Rating/Material

NEMA Type 4X indoor / IP66, stainless steel

Digital Specifications

Microcomputer	Motorola ColdFire® MCF5307 main processor at 90 MHz
Digital Filter	Software selectable: 1–256, enhanced Rattletrap® hybrid digital filtering

Additional Communications Options

Ethernet TCP/IP
4-wire RS-485
USB

Enclosure Dimensions (W x H x D)

Universal Enclosure	10.5" x 7.25" x 3.52" (26.67 x 18.42 x 8.94 cm)
Panel Mount Controller	11.0" x 2.14" x 6.05" (27.94 x 5.44 x 15.37 cm)
Panel Mount Display	7.36" x 3.86" x 1.58" (18.69 x 9.80 x 4.01 cm)

Warranty

Two-year limited warranty

Certifications and Approvals



NTEP
CoC Number 08-022
Accuracy Class III/IIIL n_{max} : 10 000



Universal Model
File Number: E151461



Panel Mount Model
File Number: E151461, Vol 2



Measurement Canada
Approval AM-5677C
Accuracy Class III/IIHD n_{max} : 10 000



Norma Oficial Mexicana
Certificate Number: 1502CE03302



US Radio Certificate Number: R68WIPORTG
Canada Radio Certificate Number: 3867A-WIPORTG





© Rice Lake Weighing Systems Content subject to change without notice.

230 W. Coleman St. • Rice Lake, WI 54868 • USA USA: 800-472-6703 • International: +1-715-234-9171