



Analog Output Option Card Installation

The Analog Output Option Card provides a single analog output port for an 880 indicator when installed. The Analog Output Option Card attaches to the 880 CPU board and is configured in the Analog Output Menu (ALGOUT) within the Setup Menu of the 880. Configuration and calibration instructions for analog output are provided in the 880 Technical Manual (158387).

 **NOTE:** The Analog Output Option Card requires the 880 CPU firmware to be updated to Version 4 or newer.

The indicator automatically recognizes all installed option cards when the unit is powered on. No hardware-specific configuration is required to identify an installed option card to the system.

 Manuals and additional resources are available from the Rice Lake Weighing Systems website at www.ricelake.com
Warranty information can be found on the website at www.ricelake.com/warranties

 **WARNING:** Always disconnect power before opening an enclosure or controller assembly. Option card is not hot swappable. Procedures requiring work inside the indicator must be performed by qualified service personnel only.

 **CAUTION:** A grounding wrist strap must be worn to protect components from electrostatic discharge (ESD) when working inside an enclosure or controller assembly.

Parts Breakdown

The Analog Output Option Card kit (179156) contains the necessary items used for installation of the option card.

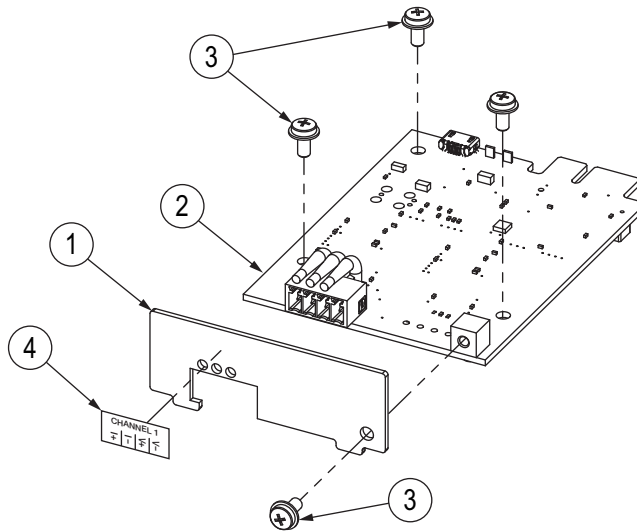

Figure 1. Analog Output Option Card Parts Breakdown

Item No.	Part No.	Description	Qty.	Item No.	Part No.	Description	Qty.
1	181658	Faceplate, Analog Output	1	-	53075	Clamp, Ground Cable Shield, 0.078"	1
2	164704	Board Assembly, Analog Output	1	-	67550	Clamp, Ground Cable Shield, 0.125"	1
3	14822	Screw, Machine 4-40 x 1/4	4	-	15139	Washer, No. 10 Lock	1
4	167196	Label, Single Analog Output Option	1	-	14621	Nut, Keps 6-32 Hex	1
-	153878	Connector, 4 Position Screw Terminal	1	-	200273	Addendum, Analog Output Card	1

Table 1. Analog Output Option Card Parts List

Panel Mount Installation

1. Disconnect power to the indicator.
2. Unhook the controller assembly from the front panel DIN rail by inserting a flat blade screwdriver into the bottom tab and sliding the mounting plate down (Figure 2). Due to the angle of the hook portion of the DIN bracket, it may be a little tight as it is disconnected.

! **IMPORTANT:** Carefully separate the controller assembly from the front panel. The display cable harness still connects the front panel to the controller assembly.

3. Disconnect the display cable harness from the controller assembly.

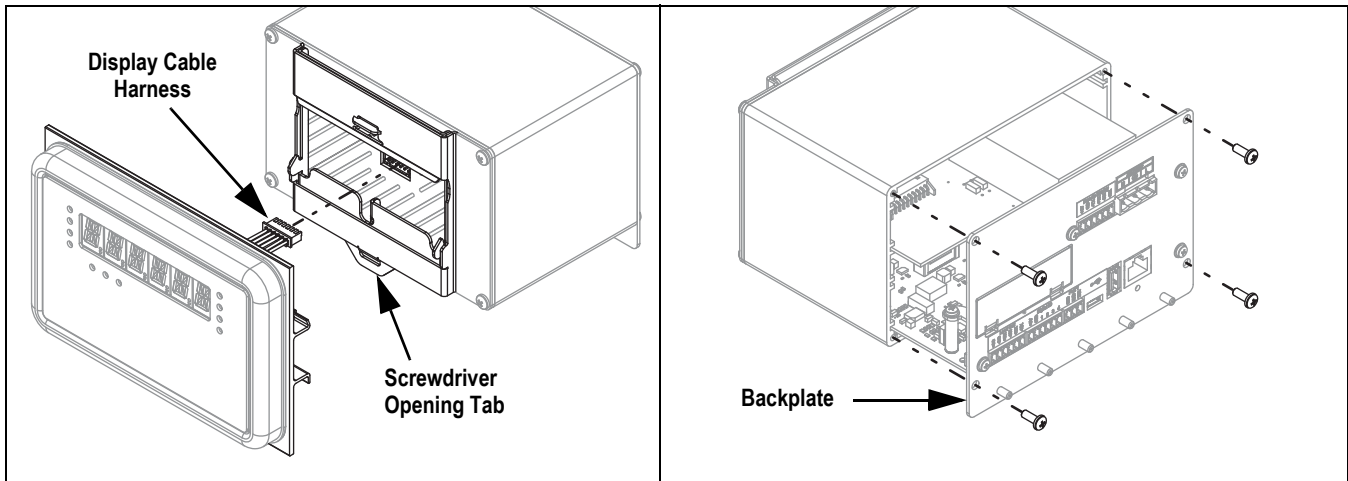

Figure 2. Front Panel and Backplate Removal

4. Remove the four screws securing the controller assembly backplate to the enclosure and carefully pull the backplate straight out from the enclosure.

! **IMPORTANT:** Removing the backplate from the enclosure voids the Legal for Trade status if enclosure is sealed.

5. Remove the two screws securing the power supply board to the backplate and carefully lay the power supply down.

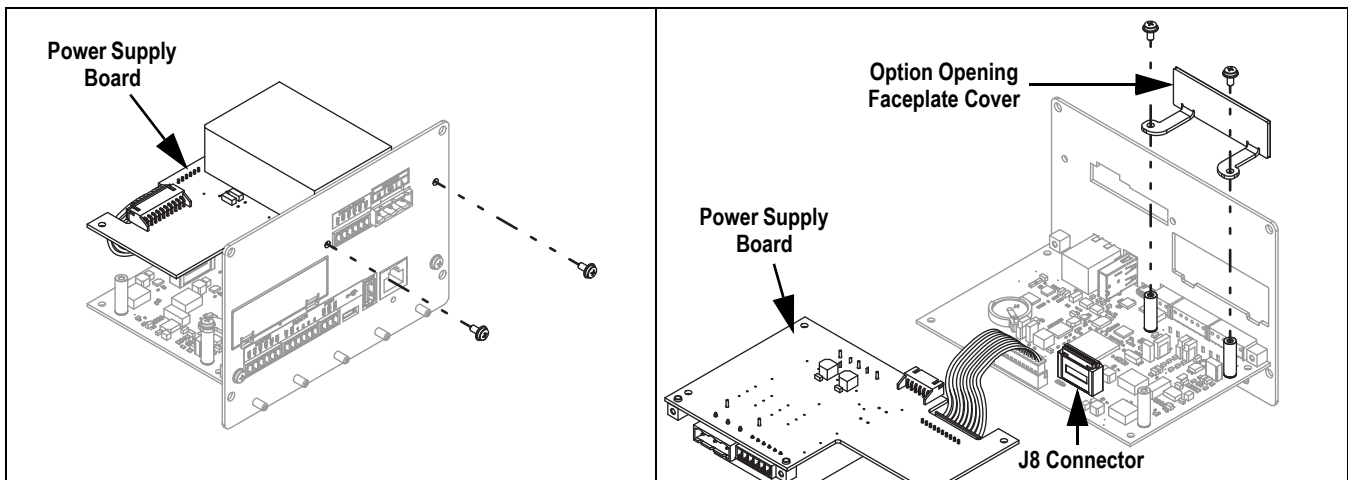

Figure 3. Power Supply Board and Faceplate Cover Removal

6. Remove the two screws securing the option opening faceplate cover to the CPU board standoffs.
7. Carefully align the J5 connector on the bottom of the option card board with the J8 connector on the 880 CPU board.

8. Press down on the option card board until it is seated on the 880 CPU board connector.

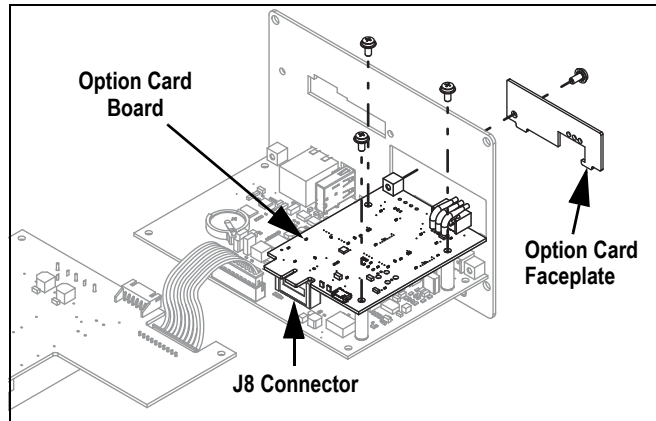

Figure 4. Option Card Board and Faceplate Installation

9. Use three provided option kit screws to secure the option card board to the threaded standoffs on the 880 CPU board.
10. Use the remaining screw provided in the option card kit to secure the option card faceplate to the threaded mounting block on the option card board within the option opening of the 880 panel mount backplate.
11. Reconnect the power supply board to the backplate with the two previously removed screws.
12. Slide backplate with boards into the controller assembly enclosure, ensuring that each board is seated correctly in the grooves of the enclosure.



NOTE: Before securing the backplate, verify the display connector aligns properly with the front cutout. If not aligned, remove the backplate with boards and re-insert so the display connector aligns with the front cutout.

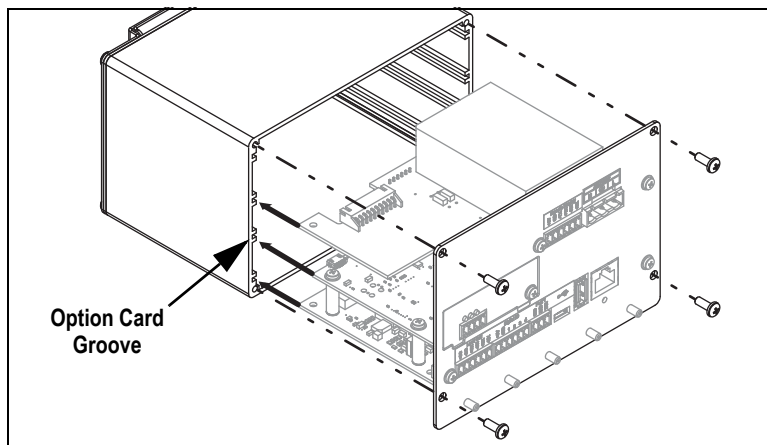

Figure 5. Backplate with Boards Reassembly

13. Secure backplate to controller assembly enclosure with the four previously removed corner screws.
14. Reconnect the display cable harness and then reconnect the controller assembly to the front panel DIN rail.
15. Connect necessary cable(s). See [Connection Pin Assignments](#) on page 5 for additional information.
16. Shield ground the cable(s) using a cable clamp, washer and nut provided in the option card kit and a grounding stud on the controller assembly backplate.



NOTE: See the 880 technical manual (158387) for additional information on shield grounding.

17. Reconnect power to the indicator.
18. If needed, see the 880 technical manual (158387) for additional information on Analog Output configuration.

LED Status Indicators

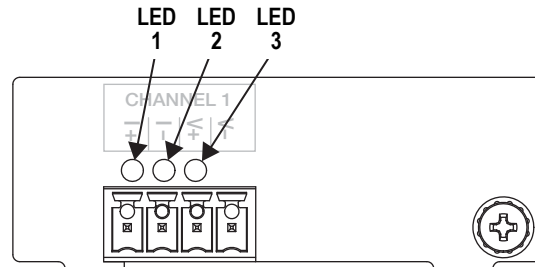

Figure 6. Analog Output Option Card Faceplate

LED	Status
1	LED Card Status
2	Green LED – Channel is good when lit
3	Red LED – Channel is faulty when lit

Table 2. LED Status Descriptions

Universal Mount Installation

1. Disconnect power to the indicator.
2. Remove the backplate of the enclosure as instructed in the 880 technical manual (158387) to access the CPU board.
3. Carefully align the J5 connector on the bottom of the option card board with the J8 connector on the 880 CPU board.

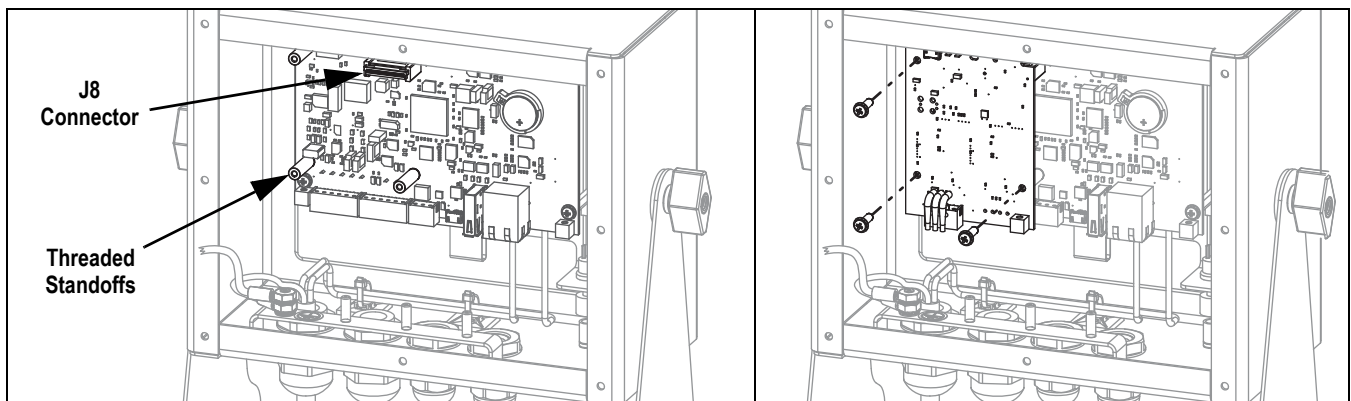

Figure 7. Option Card Board Installation

4. Press down on the option card board until it is seated on the 880 CPU board connector.
5. Use three provided option kit screws to secure the option card board to the threaded standoffs on the 880 CPU board.



NOTE: The provided faceplate is not needed when installing the option card inside of the 880 universal enclosure.

6. Route and connect necessary cable(s). See [Connection Pin Assignments](#) for additional information.
7. Shield ground the cable(s) using a cable clamp, washer and nut provided in the option card kit and a grounding stud on the enclosure.



NOTE: See the 880 technical manual (158387) for additional information on shield grounding.

8. Secure the backplate and then reconnect power to the indicator.
9. If needed, see the 880 technical manual (158387) for additional information on Analog Output configuration.

Connection Pin Assignments



NOTE: The indicator automatically recognizes installed option cards when the unit is powered on. No hardware-specific configuration is required to identify the newly-installed card to the system.

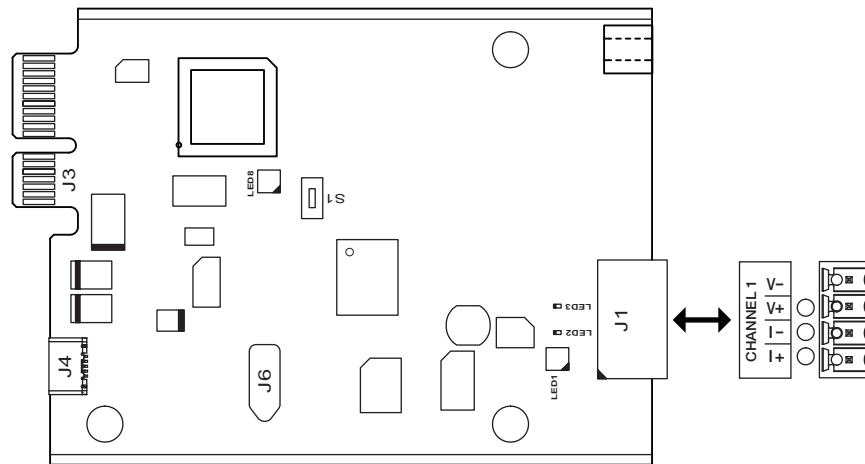

Figure 8. Analog Output Option Card Board

J1 Pin	Signal
1	I+ (Current Out)
2	I- (Current Out)
3	V+ (Voltage Out)
4	V- (Voltage Out)

Table 3. Pin Assignments

Specifications

Resolution:	16-bit, monotonicity over temperature
Linearity:	$\pm 0.03\%$ of full scale input
Current Output:	0–20 mA or 4–20 mA (20% offset)
Maximum Load Resistance:	840 Ω
Voltage Output:	0–10 VDC
Minimum Load Resistance:	1.1 K Ω
Input Protection:	Short circuit protection, 300 W transient voltage suppression Protection for ESD, EFT (electrical fast transients), tertiary lightning, and system-generated transients per IEC 60001-4-2, 60001-4-4, and 60001-4-5; European Standards EN50082 and EN61000-4



© Rice Lake Weighing Systems Specifications subject to change without notice.

230 W. Coleman St. ▪ Rice Lake, WI 54868 ▪ USA
U.S. 800-472-6703 ▪ Canada/Mexico 800-321-6703 ▪ International 715-234-9171 ▪ Europe +31 (0)26 472 1319