

880 Performance™ Series

Controller/Indicator
Firmware Version 4.0

Technical Manual



REVOLUTION
SCALE SOFTWARE

RICE LAKE
WEIGHING SYSTEMS

March 1, 2024

PN 158387 Rev I

© Rice Lake Weighing Systems. All rights reserved.

Rice Lake Weighing Systems® is a registered trademark of
Rice Lake Weighing Systems.

All other brand or product names within this publication are trademarks or
registered trademarks of their respective companies.

All information contained within this publication is, to the best of our knowledge, complete and
accurate at the time of publication. Rice Lake Weighing Systems reserves the right to make
changes to the technology, features, specifications and design of the equipment without notice.

The most current version of this publication, software, firmware and all other product
updates can be found on our website:

www.ricelake.com

Revision History

This section tracks and describes manual revisions for awareness of major updates.

Revision	Date	Description
H	December 7, 2022	Revision history established. Added UL and Revolution updates.
I	March 1, 2024	Added first and second generation option card details

Table i. Revision Letter History



Technical training seminars are available through Rice Lake Weighing Systems. Course descriptions and dates can be viewed at www.ricelake.com/training or obtained by calling 715-234-9171 and asking for the training department.

Contents

1.0	Introduction	9
1.1	Safety	9
1.2	Overview	10
1.3	Operating Modes	11
1.3.1	Weigh Mode	11
1.3.2	Configuration Mode	11
1.3.3	User Setup Mode	11
1.4	FCC Compliance	11
1.5	Front Panel Display	12
1.6	Menu Structures and Parameter Descriptions	13
1.6.1	Navigating Through Levels	13
1.6.2	Edit Parameter Values	14
1.6.3	Alphanumeric Entry Procedure	14
1.6.4	Numeric Values Editing Procedure (880 Plus Only)	14
1.7	Indicator Operations	15
1.7.1	Toggle Gross/Net Mode	15
1.7.2	Toggle Units	15
1.7.3	Zero Scale	15
1.7.4	Acquire Tare	15
1.7.5	Remove Stored Tare Value	15
1.7.6	Preset Tare (Keyed Tare)	16
1.7.7	Print Ticket	16
1.7.8	Front Panel User Setup	16
1.7.9	Displaying Audit Trail Information	16
1.7.10	Setpoints	17
1.7.11	Display or Edit Setpoint Value	17
1.7.12	Turn Setpoint On or Off	18
1.7.13	Set Time and Date	18
1.7.14	Display Accumulator	19
1.7.15	Clear the Accumulator	19
1.7.16	Display Tare	19
2.0	Installation	20
2.1	Unpacking and Assembly	20
2.2	Panel Mount Installation	20
2.2.1	Mounting the Controller Assembly Remotely	22
2.2.2	Controller Box Disassembly	24
2.2.3	Remove Backplate of Controller Assembly	25
2.2.4	Display Board Replacement	26
2.2.5	Board Replacement	26
2.3	Universal Mount Installation	28
2.3.1	Remove Back Panel	28
2.3.2	Board Replacement	29
2.4	Cable Connections	30
2.4.1	Cable Specifications	30
2.4.2	Load Cells	30
2.4.3	Power Connections – 880 Panel Mount	31
2.4.4	AC Cable Grounding in 880 Universal	32



Rice Lake continually offers web-based video training on a growing selection of product-related topics at no cost. Visit www.ricelake.com/webinars

2.4.5	DC Cable Grounding in 880 Universal	33
2.4.6	Serial Communications – Port 1 (COM)	33
2.4.7	Optional Dual Serial Expansion Card	34
2.4.8	USB Device Communications – Port 2 (USBCOM)	34
2.5	USB Host	35
2.6	Ethernet Communications	35
2.7	CPU Board (175109 - Blue)	36
2.8	Audit Trail	36
2.9	Digital I/O	37
2.10	Legal for Trade Sealing	37
2.10.1	880 Panel Mount Sealing	37
2.10.2	880 Universal Mount Sealing	39
2.11	Option Cards	39
2.12	Battery Replacement	40
2.13	Panel Mount Replacement Parts	40
2.13.1	Panel Mount Parts Kits	41
2.14	Universal Mount Replacement Parts	42
3.0	Configuration	44
3.1	Configuration Methods	44
3.2	User Setup Menu	45
3.2.1	Audit Menu	45
3.2.2	Setup Menu	46
3.2.3	Scale Menu	46
3.2.4	Format Menu	48
3.2.5	Calibration Menu	50
3.2.6	Feature Menu	51
3.2.7	Region Menu	53
3.2.8	Ports Menu	55
3.2.9	COM, USBCOM, and SERIAL Menus	56
3.2.10	Ethernet Menu	58
3.2.11	USB Host	59
3.2.12	Fieldbus Menu	60
3.2.13	Print Format Menu	61
3.2.14	Setpoints Menu	62
3.2.15	Version Menu	66
3.2.16	Digital I/O Menu	67
3.2.17	Analog Output Menu	68
4.0	Calibration	69
4.1	Front Panel Calibration	70
4.1.1	Five-point linearization	71
4.1.2	Rezero	71
4.2	LAST – Calibrating Zero Without Removing Test Weights	72
4.3	TEMP – Establishing a Temporary Zero for Calibrating a Loaded Scale	72
4.4	Adjusting Final Calibration (Trimming)	72
4.5	Gravity Compensation	72
4.6	EDP Command Calibration	72
4.7	Revolution Calibration	73
5.0	Using Revolution	74



Technical training seminars are available through Rice Lake Weighing Systems. Course descriptions and dates can be viewed at www.ricelake.com/training or obtained by calling 715-234-9171 and asking for the training department.

5.1	Connecting to the Indicator	74
5.2	Configuration	74
5.2.1	New Configuration File	74
5.2.2	Open an Existing Configuration File	75
5.2.3	Saving a Configuration File	75
5.2.4	Downloading to the Indicator	75
5.2.5	Uploading Configuration to Revolution	75
5.3	Updating the Indicator CPU or Display Module Firmware	76
5.4	Revolution Help	76
6.0	EDP Commands	77
6.1	The EDP Command Set	77
6.1.1	Key Press Commands	77
6.1.2	Reporting Commands	78
6.1.3	The RESETCONFIGURATION Command	79
6.1.4	Parameter Setting Commands	79
6.1.5	Scales Menu	79
6.1.6	Format Menu	80
6.1.7	Calibration Menu	80
6.1.8	Ports COM and SERIAL (Option Card) Menu	81
6.1.9	Ports – Fieldbus Menu	81
6.1.10	Ports – Ethernet Menu	82
6.1.11	Ports – USB COM Menu	83
6.1.12	Stream Tokens Menu	83
6.1.13	Feature Menu	83
6.1.14	Regulatory Menu	84
6.1.15	Time and Date Menu	84
6.1.16	Passwords Menu	84
6.1.17	Keypad Lock Menu	84
6.1.18	Setpoints Menu	85
6.1.19	Print Format Menu	88
6.1.20	Digital I/O Configuration Menu	88
6.1.21	Analog Out Menu	88
6.1.22	Weigh Mode Commands	89
6.1.23	Digital I/O Control Menu	90
6.1.24	Batching Control Commands	90
6.1.25	Database Commands	90
7.0	Print Formatting	93
7.1	Print Formatting Tokens	93
7.2	Default Print Formats	94
7.3	Customizing Print Formats	95
7.3.1	Using the EDP Commands	95
7.3.2	Using the Front Panel	95
7.3.3	Using Revolution	95
8.0	Setpoints	96
8.1	Batch and Continuous Setpoints	96
8.2	Batch Operations	97
8.2.1	Batching Switch	98
8.3	Batching Examples	99



Rice Lake continually offers web-based video training on a growing selection of product-related topics at no cost. Visit www.ricelake.com/webinars

9.0 Ethernet and USB	101
9.1 Ethernet Server/Client Connections	101
9.1.1 Ethernet Server	101
9.1.2 Ethernet Client	101
9.1.3 Direct Connection from Computer to 880 Ethernet Server Without a Network (Ad-Hoc)	102
9.1.4 Computer Connection to 880 Ethernet Server Through a Network Switch or Router	102
9.1.5 Connection to a Remote Host - Demand Print to an Ethernet Printer	103
9.1.6 Connecting to a Remote Host - Stream weight data to an Ethernet Remote Display	104
9.1.7 Connecting to a Remote Host, Stream/Demand Data to Remote Ethernet-to-RS-232 Device Server	104
9.2 USB Host	105
9.2.1 Using a USB Keyboard	105
9.2.2 USB Memory storage	106
10.0 Appendix	107
10.1 Error Messages	107
10.1.1 Displayed Error Messages	107
10.2 Status Messages	107
10.3 Using the HARDWARE Command	108
10.4 ERROR Commands Output	108
10.5 TARE and ZERO Key Functions	109
10.6 Data Formats	110
10.6.1 Stream Serial Data Format	110
10.6.2 Print Output Serial Data Format	110
10.6.3 RS-485 Data Formats	111
10.7 Custom Stream Formatting – Input/Output	112
10.8 Stream Formatting Examples	114
10.8.1 Toledo 8142 Indicator	114
10.8.2 Cardinal 738 Indicator	115
10.8.3 Weightronix WI 120 Indicator	115
10.9 ASCII Character Chart	116
10.10 Digital Filtering	118
10.10.1 Sample Rate	118
10.10.2 Digital Filter	118
10.11 Analog Output Calibration	119
10.12 Option Card Firmware Update Procedure	120
11.0 Compliance	122
12.0 Specifications	123



Technical training seminars are available through Rice Lake Weighing Systems. Course descriptions and dates can be viewed at www.ricelake.com/training or obtained by calling 715-234-9171 and asking for the training department.



Rice Lake continually offers web-based video training on a growing selection of product-related topics at no cost. Visit www.ricelake.com/webinars

1.0 Introduction

This manual is intended for use by service technicians responsible for installing and servicing 880 digital weight indicators.



IMPORTANT: This manual applies to indicators using Version 3 or newer of the 880 firmware and the new 880 CPU board, PN 175109 (blue in color). Please be advised, past generation boards and parts are not interchangeable with the new boards and parts. see [Section 2.13 on page 40](#) for drawing and replacement part information.



NOTE: New 880 CPU boards are 5.5" wide and are not interchangeable with previous boards which were 5.0" wide.



Manuals are available from Rice Lake Weighing Systems at www.ricelake.com/manuals

Warranty information is available at www.ricelake.com/warranties

1.1 Safety

Safety Definitions:



DANGER: Indicates an imminently hazardous situation that, if not avoided, will result in death or serious injury. Includes hazards that are exposed when guards are removed.



WARNING: Indicates a potentially hazardous situation that, if not avoided, could result in serious injury or death. Includes hazards that are exposed when guards are removed.



CAUTION: Indicates a potentially hazardous situation that, if not avoided, could result in minor or moderate injury.



IMPORTANT: Indicates information about procedures that, if not observed, could result in damage to equipment or corruption to and loss of data.

General Safety



Do not operate or work on this equipment unless this manual has been read and all instructions are understood. Failure to follow the instructions or heed the warnings could result in injury or death. Contact any Rice Lake Weighing Systems dealer for replacement manuals.



WARNING: Failure to heed could result in serious injury or death.

Procedures requiring work inside the indicator must be performed by qualified service personnel only.

Do not allow minors (children) or inexperienced persons to operate this unit.

Do not operate without the enclosure completely assembled.

Do not use for purposes other than weight taking.

Do not place fingers into slots or possible pinch points.

Do not use this product if any of the components are cracked.

Do not exceed the rated specification of the unit.

Do not make alterations or modifications to the unit.

Do not remove or obscure warning labels.

Do not submerge.

Before opening the unit, ensure the power cord is disconnected from the outlet.

Ensure the outlet is located in an easily accessible area.

1.2 Overview

The 880 is a programmable single-channel digital weight indicator, available in a panel mount or universal enclosure.

The front panel can be sealed to a NEMA Type 4X/IP69K rating. The front panel consists of a six-button keypad and a six-digit, 14-segment LED display. The Universal front panel includes a numeric key pad.

Features include:

- LED display, 0.56 in (14 mm), six-digit, 14-segment
- RS-232 or RS-485 serial port
- USB device port connects directly to a PC
- Ethernet TCP/IP polled or continuous - supporting both a server and client connection
- AC or DC models
- Built-in DIN-rail clips on controller box (panel mount)
- Display and controller can be separated up to 250' (panel mount)
- Expansion slot for one option card
- Operator functions through menu key for audit trail, preset tare, accumulator, time & date, Ethernet MAC ID and setpoints
- Audit trail tracking for configuration and calibration changes; password protection for user and configuration changes
- 20 setpoints with latched batch engine or unlatched outputs
- Four onboard digital I/O channels
- Programmable ticket formats up to 1,000 characters for header text, gross, net, accumulator and setpoints
- Local/remote operation
- Multi-range or multi-interval weighing
- Filter settings for light, medium and heavy noise

Options/Accessories:

- Metrological hardware sealing kit
- Adapter plate for converting 310 A and 520 panel mounts
- Panel mount kit for universal enclosure

Network Cards:

- 179158 Indicator Option, EtherCat Model 880 Indicator
- 179159 Indicator Option, Ethernet/IP Model 880 Indicator
- 179160 Indicator Option, Profinet Model 880 Indicator
- 179161 Indicator Option, Modbus TCP Model 880 Indicator
- 179162 Indicator Option, Devicenet Model 880 Indicator
- 179163 Indicator Option, Profibus Model 880 Indicator

1.3 Operating Modes

The three modes of operation for the 880 are described in the following sections.

1.3.1 Weigh Mode

In this mode, the indicator displays gross or net weights and annunciators to indicate scale status and type of weight value displayed.

1.3.2 Configuration Mode

Many of the procedures described in this manual, require the indicator to be in configuration mode, see [Section 3.0 on page 44](#). The 880 has an Audit Trail that tracks changes to configuration and calibration, allowing the setup switch to be bypassed with Jumper J4 on the CPU board. If Audit Trail is enabled, configuration mode can be accessed through the user setup mode.

1.3.3 User Setup Mode

User setup mode, accessed by pressing , allows the following configuration steps:

- View the audit trail
- Set time and date
- View the Ethernet MAC Address
- View or clear accumulator value
- Change setpoint values
- View current tare value
- Enter configuration mode (if audit trail is enabled)

See [Section 1.7.8 on page 16](#) for more information about entering user setup mode.

1.4 FCC Compliance

United States

This equipment has been tested and found to comply with the limits for a Class A digital device, pursuant to Part 15 of the FCC Rules. These limits are designed to provide reasonable protection against harmful interference when the equipment is operated in a commercial environment. This equipment generates, uses and can radiate radio frequency energy and, if not installed and used in accordance with the instruction manual, may cause harmful interference to radio communications. Operation of this equipment in a residential area is likely to cause harmful interference in which case the user will be required to correct the interference at his own expense.

Canada

This digital apparatus does not exceed the Class A limits for radio noise emissions from digital apparatus set out in the Radio Interference Regulations of the Canadian Department of Communications.

Le présent appareil numérique n'émet pas de bruits radioélectriques dépassant les limites applicables aux appareils numériques de la Class A prescrites dans le Règlement sur le brouillage radioélectrique édicté par le ministère des Communications du Canada.

1.5 Front Panel Display

The front panel consists of a six-button keypad and a six-digit, 14-segment LED display. The Universal front panel includes a numeric key pad.

The numeric display consists of six 14-segment LED digits. If a negative number is displayed, the first digit is used to display -, reducing the number of available digits to five.

The symbols on the keys in [Figure 1-1](#) (representing up, down, enter, left, right) describe the key functions when in configuration mode. The keys are used to navigate through menus, select digits within numeric values, and increment/decrement values, see [Section 3.2 on page 45](#) for information about using the front panel keys in configuration mode.

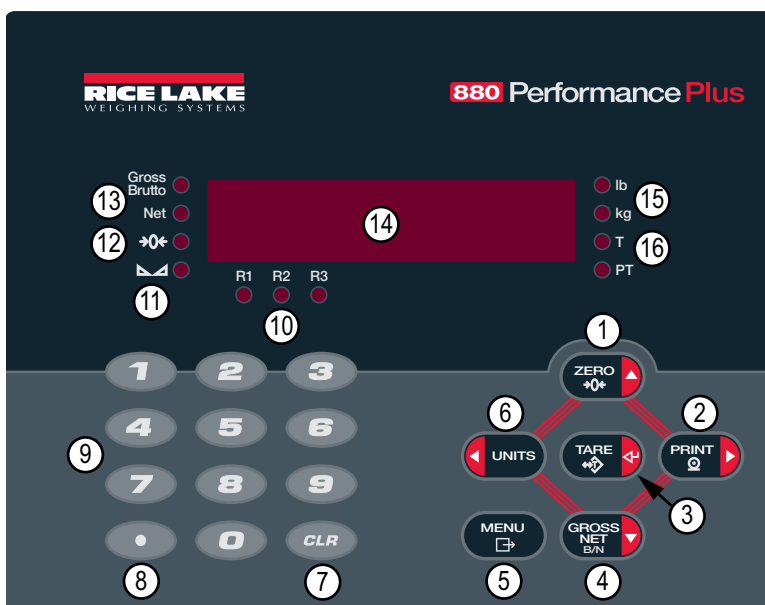

Figure 1-1. 880 Front Panel Display (Universal Model Shown)

Item No.	Function
1	Sets the current gross weight to zero; used to navigate to other menus or to select another digit when editing a value
2	Sends an on-demand print format to a communications port, provided the conditions for printing are met; Print can be configured to display while the unit is printing; used to navigate to other menus or select another digit when editing a value
3	Performs several predetermined tare functions dependent on the mode of operation selected in the TAREFN ; acts as enter for numeric or parameter entry
4	Toggles displayed weight between gross and net mode; if a tare value has been entered or acquired, the net value is the gross weight minus the tare; gross mode is indicated by the Gross/Brutto annunciator; net mode is indicated by the Net annunciator; used to navigate to different menus or to select another digit when editing a value
5	Allows access to the user setup menu; also acts as the cancel key when editing parameter values, or Exit key when in the configuration or user setup menus
6	Switches the weight display to an alternate unit, defined in the format menu, see Section 3.2.4 on page 48 ; units available: lb, kg, oz, metric ton, ton, gram; used to navigate to different menus or to select another digit when editing a value
7	Clears a numeric entry from the LCD (not available with the panel mount)
8	Inserts a decimal point where necessary (not available with the panel mount)
9	The Numeric Keypad can be used to enter values; values may also be entered by scrolling through values with the arrow keys (not available with the panel mount)
10	Indicates the current range when configured for multi-range or multi-interval R1, R2, R3
11	Scale is at standstill or within the specified motion band; some operations, including Zero, Tare and Printing, can only be completed when the LED is lit





Table 1-1. Key Functions

Item No.	Function
12	Indicates that the current gross weight reading is within ± 0.25 display divisions of the acquired zero, or is within the center of zero band; a display division is the resolution of the displayed weight value, or the smallest incremental increase or decrease that can be displayed or printed
13	Gross weight mode (or Brutto in OIML mode) Net weight mode
14	Indicator display area
15	lb/kg LED – the lb and kg annunciators indicate the units associated with the displayed value. If the displayed value is pounds, lb will be lit. If the displayed value is kilograms, kg will be lit; primary or secondary units – if the primary or secondary units value is neither lb or kg, then lb will be lit for the units assigned as primary, and kg will be lit for the units assigned as secondary; lb/tn, t, oz, g, or none – alternate conversions that can be displayed include short tons (tn), metric tons (t), ounces (oz), grams (g), or NONE (no units); if the displayed units is one of these alternate conversions, and the other unit value is lb, then kg will be lit; tn, t, oz, g, or none – alternate conversions that can be displayed include short tons (tn), metric tons (t), ounces (oz), grams (g), or NONE (no units); if the displayed units is one of these alternate conversions, and the other unit value is kg, then lb will be lit
16	T LED – indicates that a tare has been acquired and stored by the system; PT LED – indicates that a preset tare weight has been keyed in or received via an EDP command

Table 1-1. Key Functions (Continued)

1.6 Menu Structures and Parameter Descriptions

The front panel keys are used to navigate through the menus in configuration mode, see [Figure 1-2](#).

-  and  move left and right (horizontally) in a menu level
-  and  move up and down (vertically) to different menu levels
-  serves as an enter key for selecting parameter values within the menus

1.6.1 Navigating Through Levels

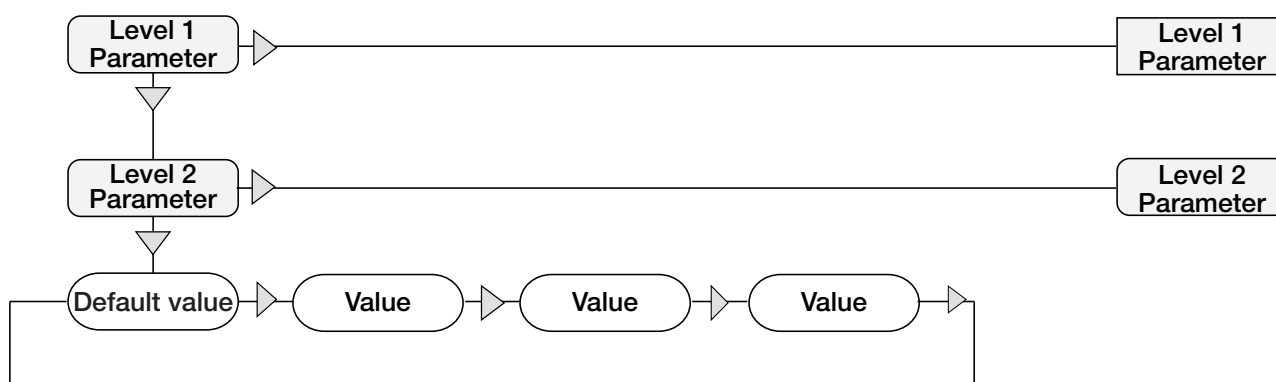









When moving through values below the first menu level, press  to return to the level above. Press  or  to move to the next parameter on that level.

Figure 1-2. Configuration Mode Menu Navigation

To select a parameter, press  or  to scroll left or right until the desired menu group appears on the display, then press  to move down to the sub-menu or parameter to be edited. When moving through the menu parameters, the current selected value appears first on the display.

1.6.2 Edit Parameter Values

To change a parameter value, scroll left or right to view the values for that parameter. When the desired value appears on the display, press  to select the value and move back up one level. To edit numerical values, use the navigation keys to select the digit and to increment or decrement the value. Alternatively, use the numeric keypad (universal enclosure only), to enter the digits. The decimal point will begin flashing if a decimal value is allowed. Use the navigation keys, to move the decimal point left or right. Press  when done.

1.6.3 Alphanumeric Entry Procedure

Use the following scheme for alphanumeric entry when using the five-button keypad.

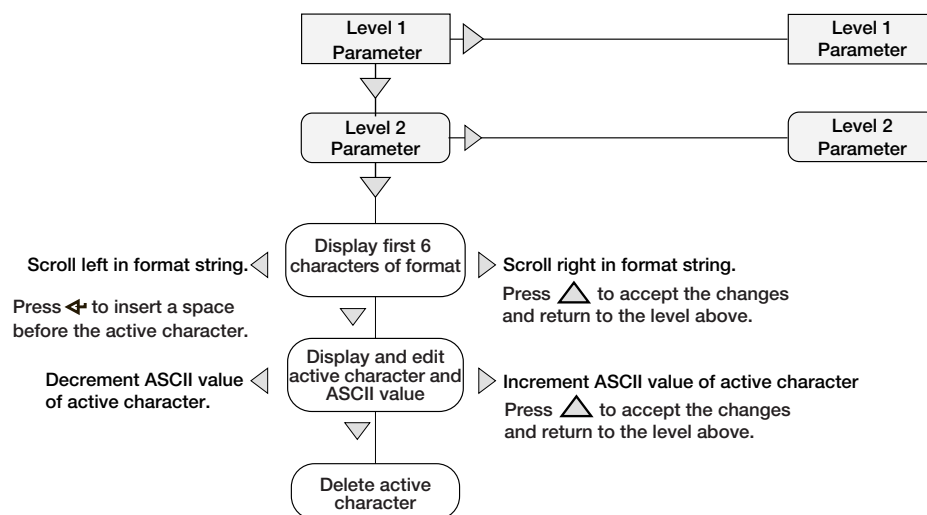

Figure 1-3. Editing Procedure for Numeric Values

1.6.4 Numeric Values Editing Procedure (880 Plus Only)

When using the numeric keypad option, the method for editing numeric values relies on the numbers which are embossed on the keypad (as opposed to using the arrows).

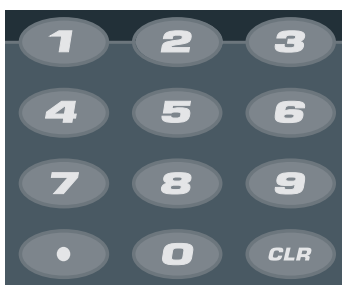





Figure 1-4. Numeric Keypad

- Using the numeric keypad, insert the required value.
 - Press  to clear the currently selected digit
 - Press  to enter a decimal point
- Press  to save the value entered and return to the level above.

 **NOTE:** When editing fractional numeric values, the decimal point must be positioned in accordance with the primary units formatting, otherwise the keyed number may be rejected by the software.

1.7 Indicator Operations

Basic 880 operations are summarized below.

1.7.1 Toggle Gross/Net Mode





1. Press  to toggle the display mode between gross and net.

 **NOTE:** Net mode is available when a tare value has been entered or acquired (Net = Gross minus Tare). If tare has not been entered or acquired, the display remains in gross mode. The LEDs next to Gross or Net indicate the current mode.

1.7.2 Toggle Units



Press  to switch between primary and secondary units. The current unit's LED will be lit.

1.7.3 Zero Scale







1. In gross mode, remove all weight from the scale and wait for the   LED to light.
2. Press . The  **0**  LED lights to indicate the scale is zeroed.

 **NOTE:** The scale must be stable and within the configured zero range for the scale to be zeroed. If the scale cannot be zeroed, NOZERO is displayed.

1.7.4 Acquire Tare

1. Place a container on the scale and wait for the   LED to light.
2. Press  to acquire the tare weight of the container. The Net weight is displayed and the T LED lights to show the tare value was entered.

1.7.5 Remove Stored Tare Value



1. Remove all weight from the scale and wait for the   LED to light. The display should read zero and the  **0**  LED should be lit.
2. Press  to zero the scale if needed.
3. Press  (or  in OIML mode). Display shifts to gross weight and the Gross LED is lit.

 **NOTE:** If keyed tares are allowed, press  to open the keyed tare prompt. To clear tare, press  again.

1.7.6 Preset Tare (Keyed Tare)



NOTE: Tare mode must be set to keyed or both for the preset tare feature to function.



1. With the scale empty and zero weight on the display, press . **000000** displays with the focused digit flashing.
2. Edit the value using the keypad on the 880 Plus, see [Section 1.6.4 on page 14](#) or use the following method for the panel mount.
 - Press \triangleleft or \triangleright to select the digit
 - Press \triangle or ∇ to increment or decrement the value
 - Press  to move to the decimal point entry
 - Press \triangleleft or \triangleright to adjust the decimal point placement
 - Press  when the value is correct

The display will change to the Net mode and the PT LED lights to show the preset tare was entered.



NOTE: Entering a keyed tare of zero will remove the stored tare value.

1.7.7 Print Ticket

1. Wait for the  LED to light.
2. Press  to send data to the configured communications port.





1.7.8 Front Panel User Setup

Press  to enter user setup mode. Use User Setup to:

- View audit trail information
- Enter configuration mode if audit trail is enabled
- View or set time and date
- View the Ethernet MAC Address
- View or clear the accumulator
- Change setpoint values and enable/disable setpoints
- View the current tare value

1.7.9 Displaying Audit Trail Information

The Audit Trail Configuration and Calibration counters can be viewed through the User Setup Menu.

1. Press . **Audit** is displayed.
2. Press ∇ to display the Legally Relevant Firmware version.
3. Press \triangleright to display **Calib**.
4. Press ∇ to view the Calibration Counter.
5. Press  to return to **Calib**.
6. Press \triangleright to display **CFG**.
7. Press ∇ to view the Configuration Counter.
8. Press  to return to **CFG**.
9. Press  to return to the weigh mode.

1.7.10 Setpoints

Setpoints must be enabled in the configuration mode to be accessible in the user setup mode.



IMPORTANT: *Breaking the seal to enter the configuration mode will void a Legal for Trade unit.*





To enter the configuration mode:

1. Remove the large fillister head screw from the back of the enclosure.
2. Insert a non-conductive tool into the access hole and press the setup switch. **Scale** displays.
3. Press ◀ or ▶ until **Setpts** is displayed.
4. Press ▾. **SP CFG** is displayed.
5. Press ▾. Press ◀ or ▶ to desired setpoint number.
6. Press ▾ to enter setpoint settings.
7. Select the type by pressing ◀ or ▶ to desired setting, then press ▾ to set the value. For complete list of choices, see [Section 3.2.14 on page 62](#).
8. When all settings have been made, press  to return to weighing mode.



NOTE: *Setpoints are now accessible from the front panel menu.*

1.7.11 Display or Edit Setpoint Value

1. Press . **Audit** is displayed.
2. Press ◀ or ▶ until **Setpts** is displayed.
3. Press ▾ and the first available setpoint number is displayed.
4. Press ◀ or ▶ to toggle through each setpoint that is operator accessible.
5. Press ▾. **Value** is displayed.
6. Press ▾ again to display or edit the value.
7. Edit the value using the keypad on the 880 Plus, see [Section 1.6.4 on page 14](#) or use the following method for the panel mount.
 - Press ▲ or ▼ to increment or decrement the value of the flashing digit
 - Press ◀ or ▶ to select the digit to edit
 - Press  to move to the decimal point entry
 - Press ◀ or ▶ to adjust the decimal point placement
8. Press  to accept the displayed value.
9. Repeat the above steps to set **Preact**, if enabled.
10. When all settings have been made, press  to return to weigh mode.





NOTE: *Setpoint Value and Preact Value may be accessible from the front panel in weigh mode.*

Some indicator configurations may not allow setpoint values to be changed through the front panel or may require a password to display or change the setpoint value.

1.7.12 Turn Setpoint On or Off





Turn a setpoint off at the front panel.

1. Press . **Audit** is displayed.
2. Press ◀ or ▶ until **Setpts** is displayed.
3. Press ▼ and the first available setpoint number is displayed.
4. Press ◀ or ▶ to toggle through each setpoint that is operator accessible.
5. Press ▼, then press ◀ or ▶ to Enable.
6. Press ▼, then press ◀ or ▶ to turn setpoint On/Off.
7. Press  to accept the setting.
8. Press  to return to weigh mode.





NOTE: Some indicator configurations may not allow setpoints to be turned off through the front panel or may require a password to turn the setpoint on and off.

1.7.13 Set Time and Date

1. Press . **Audit** is displayed.
2. Press ◀ or ▶ until **T&D** is displayed.
3. Press ▼. **Time** is displayed.
4. Press ▼ to enter time.
5. Edit value using the keypad on the unit, see [Section 1.6.4 on page 14](#) or use the following method for the panel mount:
 - Press ◀ or ▶ to select the digit
 - Press ▲ or ▼ to increment or decrement the value
6. Press  when the value is correct. **Date** is displayed.
7. Press ▼ to enter date.
8. Edit the value using the keypad on the 880 Plus in the specified format **MMDDYY**, **DDMMYY**, or **YYMMDD**. Press ◀ or ▶ to select the digit. Press ▲ or ▼ to increment or decrement the value.
9. Press  when the value is correct. **Time** is displayed.
10. Press  to return to weighing mode.

1.7.14 Display Accumulator

Enable the accumulator before use in either weigh mode or setpoint operations. Once enabled, weight (net weight if a tare is in the system) is accumulated whenever a print operation is performed using the  key, digital input assigned to print, setpoint **PSHACC** operation or **KPRINT** serial command. The scale must return to below the threshold value (except for the setpoint **PSHACC** operation) before the next accumulation.



1. Press  to enter the user setup mode, **Audit** is displayed.
2. Press \triangleleft or \triangleright until **Accum** is displayed.

 **NOTE:** *Accum is only displayed if the accumulator is enabled, see [Section 3.2.3 on page 46](#).*

3. Press ∇ . **View** is displayed.
4. Press ∇ to view the current accumulator value.
5. While the accumulator value is displayed, press  to print the value.

 **NOTE:** *The format of the print output can be configured using the accumulator print format, see [Section 7.0 on page 93](#).*

1.7.15 Clear the Accumulator



1. Press  to enter the user setup mode. **Audit** is displayed.
2. Press \triangleleft or \triangleright until **Accum** is displayed.
3. Press ∇ , then press \triangleleft or \triangleright until **CLR Y** is displayed.
4. Press  to clear the accumulator. **Clear** will display briefly and display returns to **CLR Y**.
5. Press  to return to the weigh mode.

 **NOTE:** *The print key only performs one accumulation, and only if the weight is above the accumulator threshold. Weight must return to below the accumulator threshold value before another accumulation is allowed.*

Accumulator threshold is configured in the setup menu, see [Section 3.2.2 on page 46](#).

1.7.16 Display Tare

When a stored Tare value is displayed, the Gross and Net LEDs will be off and $\rightarrow 0 \leftarrow$ will be lit. To display a stored tare:

1. Press .
2. Press \triangleright to tare and press ∇ to view the current tare value.
3. Press  twice to return to weigh mode.

If there is not a tare in the system, the value displayed will be zero and the Gross and Net LED will be turned off, see [Section 10.5 on page 109](#) for more information pertaining to the regulatory mode of operation.

2.0 Installation

This section describes procedures for connecting power, load cells, digital I/O and data communications cables to the indicator. Instructions for replacement of the circuit boards are included, along with assembly drawings and parts lists for service technician.



WARNING: Use anti-static protection for grounding and to protect components from electrostatic discharge (ESD) when working inside the indicator enclosure.

Procedures requiring work inside the indicator must be performed by qualified service personnel only.

The supply cord serves as the power disconnect for the 880. Ensure the power cord is unplugged prior to opening the enclosure.

2.1 Unpacking and Assembly

Immediately after unpacking, visually inspect the 880 to ensure all components are included and undamaged. The shipping carton should contain the controller, display, parts kit and manuals. If any parts were damaged in shipment, notify Rice Lake Weighing Systems and the shipper immediately.

2.2 Panel Mount Installation



NOTE: The controller can be mounted to the display DIN rail or mounted remotely up to 250 in away from display.

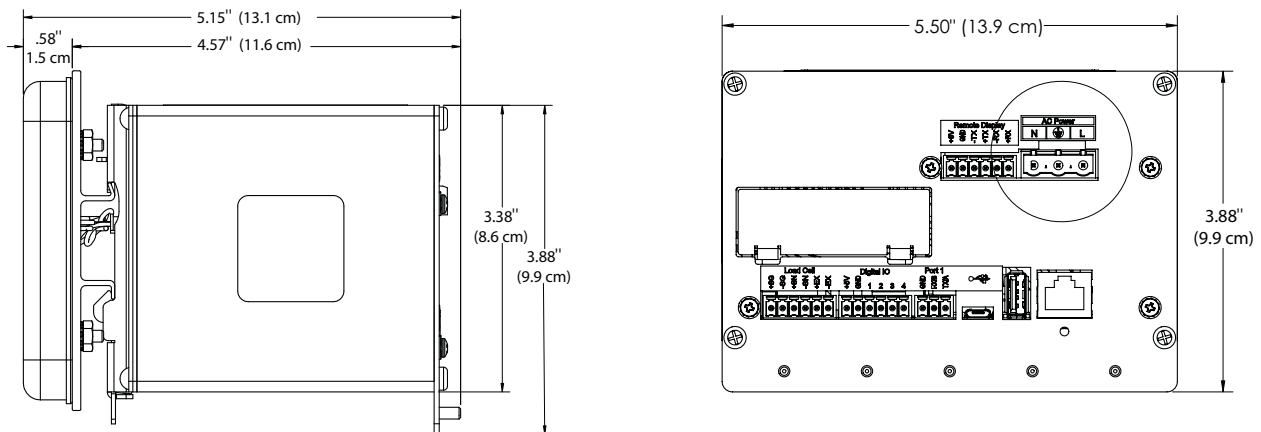

Figure 2-1. 880 Panel Mount Dimensions

Use the DIN rail mount plate as a template, see [Figure 2-2](#), to drill the mounting holes in the panel for the stainless steel panel mount enclosure.

1. Mark panel for installation using the DIN rail mount plate and drill the five holes required for mounting.



IMPORTANT: This is not a template. Drawing is for reference only.

Use DIN Rail Mount Plate as a template for drilling mounting holes in panel.

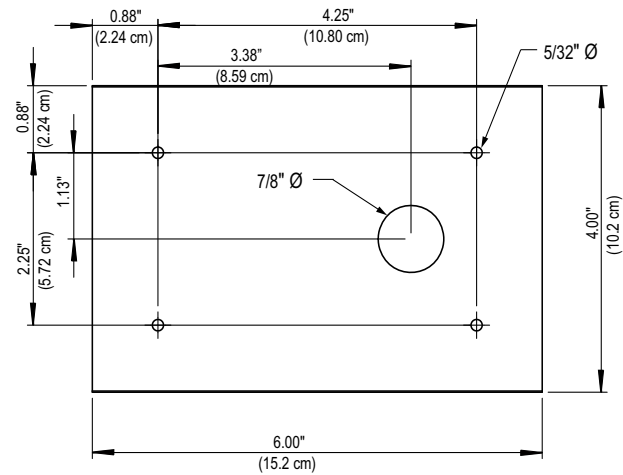

Figure 2-2. Pattern for Cutting Holes

2. Install the gasket on the display assembly. It must be seated correctly on display before mounting to ensure tight seal.
3. Align the display assembly to the front and the DIN rail mount plate to the back of the panel with holes cut, see [Step 1](#).
4. Secure display and mounting plate to the panel using the four 6-32 Kep nuts (PN 14621) provided. Torque to 8 in-lb.

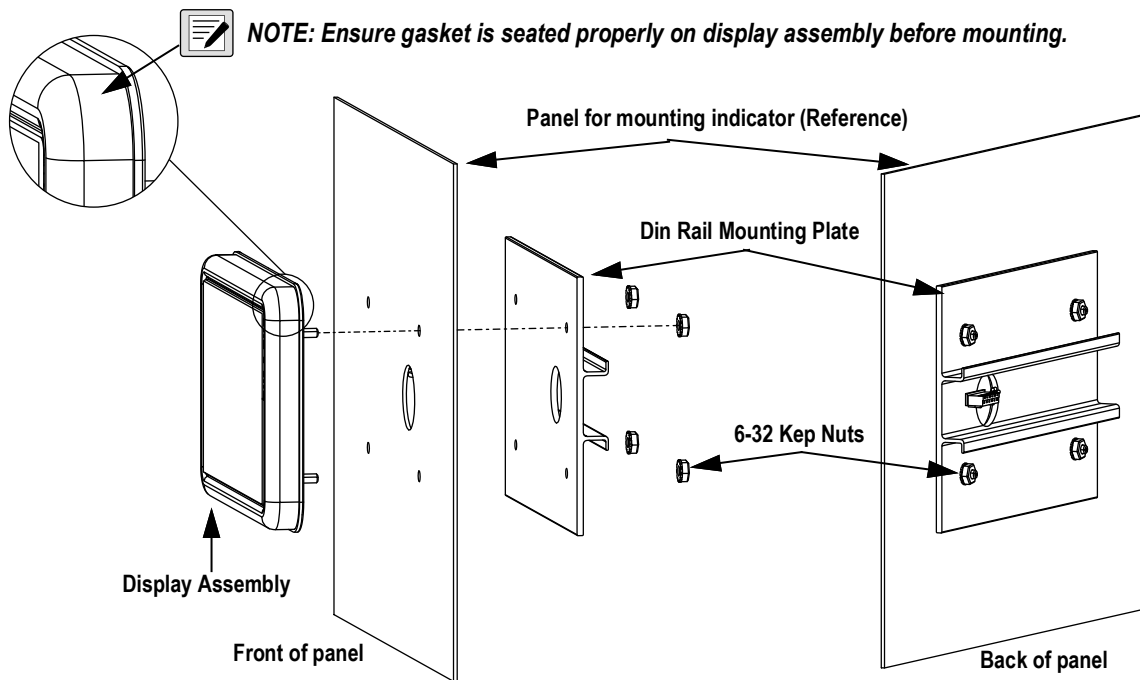

Figure 2-3. Mounting Display Assembly

5. Connect the cable assembly to the controller assembly.
6. Hook the controller assembly to the top DIN rail assembly as shown in [Figure 2-4](#).
7. Snap the bottom spring loaded latch to the bottom DIN rail so it is secure.

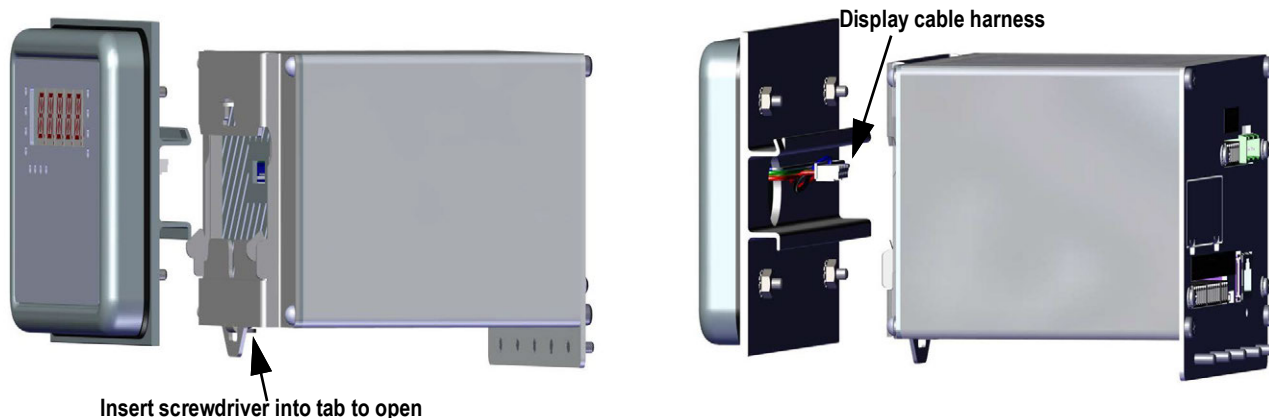

Figure 2-4. Install Controller Assembly

2.2.1 Mounting the Controller Assembly Remotely

A 6-pin connector (PN 153883) is required to mount the controller assembly remotely, see [Figure 2-5](#) for terminal location and [Table 2-1](#) for pin assignments.

NOTE: Controller assembly can be mounted remotely on a standard 35 mm DIN rail, up to 250 ft from display.

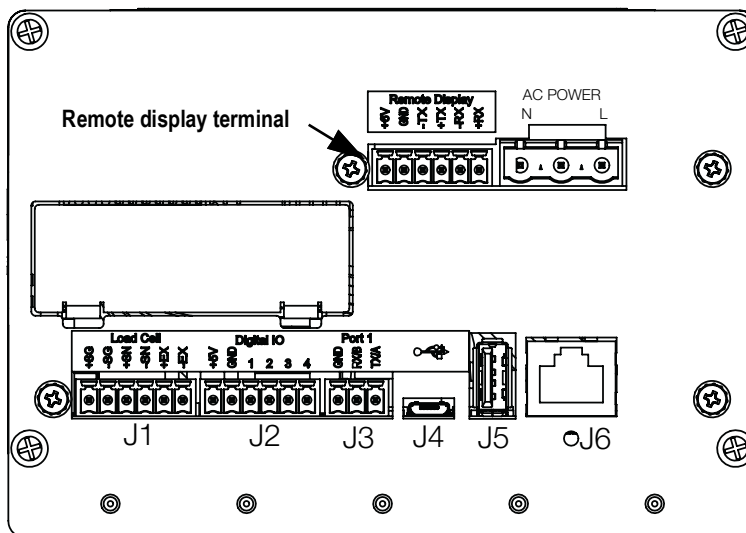



Figure 2-5. Mount Controller Assembly Remotely

Pin	Function
1	+6V
2	GND
3	-TX
4	+TX
5	-RX
6	+RX

Table 2-1. Pin Assignments

 **NOTE:** Connect to this terminal when mounting the display remotely (from the Controller Assembly).

 **NOTE:** The connector on the display board is a cage clamp style. Release by gently pressing on the connector tab if field replacement is necessary.

2 position, wire cage clamp connectors (J4, J5, J6), insert all wires in the direction shown.

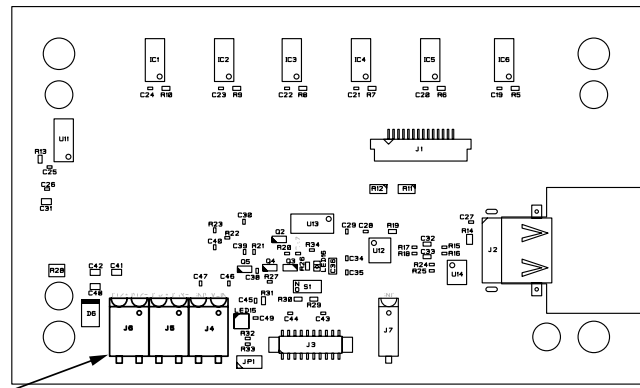
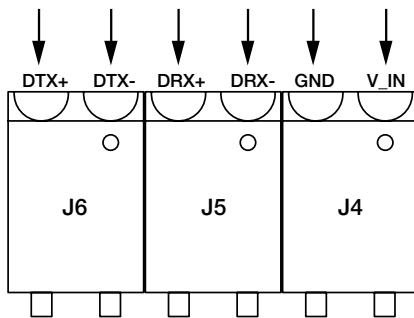

Display Board Assembly (PN 131598)

Figure 2-6. Display Board Assembly

2.2.2 Controller Box Disassembly



NOTE: Enclosure disassembly is not required to make connections for power, load cells, data communications or digital I/O. These connectors are all externally mounted on the back of the controller.

1. Disconnect power to the unit.
2. Unhook the controller assembly from the DIN rail by inserting a flat blade screwdriver on the bottom tab and sliding the mounting plate down. Due to the angle of the hook portion of the DIN bracket, it may be a little tight as it is disconnected.
3. Carefully remove the controller assembly from the DIN rail.
4. Disconnect the display cable harness shown in [Figure 2-7](#).

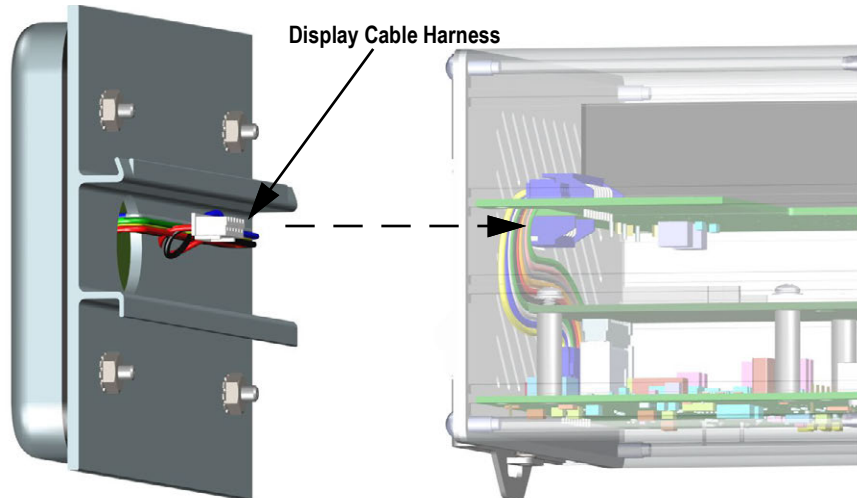

Figure 2-7. Display Cable Harness Wiring

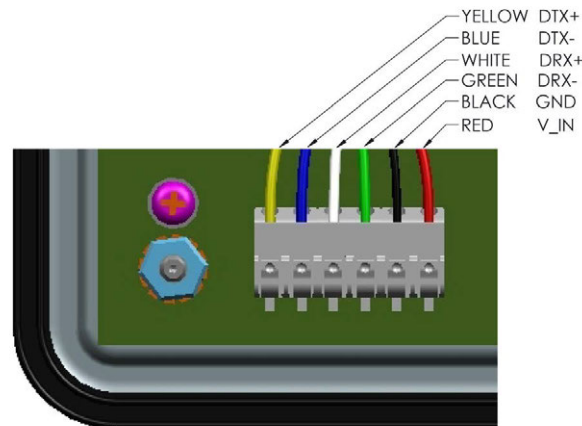

Figure 2-8. Cable Harness Wiring Breakout

2.2.3 Remove Backplate of Controller Assembly

Remove the backplate of the controller assembly to gain access to the CPU board, power supply board and installed option cards.



CAUTION: Use anti-static protection for grounding and to protect components from electrostatic discharge (ESD) when working inside the indicator enclosure.



NOTE: The CompactCom option, if installed, must be removed prior to removal of the backplate.



Figure 2-9. Remove Controller Assembly Backplate

1. Remove the four corner screws to detach the backplate from the enclosure.



NOTE: Removing the backplate from the enclosure could void the Legal for Trade status in some cases.

This leaves the CPU board and Power Supply attached to the backplate. If the display is not connected, the boards can be slid out of the enclosure, still attached to the backplate, see [Section 2.9 on page 37](#).

2. Remove the power supply board and CPU board screws to detach the backplate from the boards.
3. Remove the backplate from the controller unit.
4. To reinstall, reverse the steps above.



NOTE: If Legal for Trade is required, see [Section 2.10 on page 37](#) for sealing.

2.2.4 Display Board Replacement

If the 880 display board must be removed, use the following procedure:

1. Disconnect power to the unit.
2. Remove the controller assembly, see [Section 2.2.2 on page 24](#) and unplug the display cable harness.
3. Loosen and remove the four keps nuts securing the DIN rail and display assembly to the panel, see [Figure 2-3 on page 21](#).
4. Disconnect keypad cable assembly.
5. Remove four screws and pull display board from the display assembly.

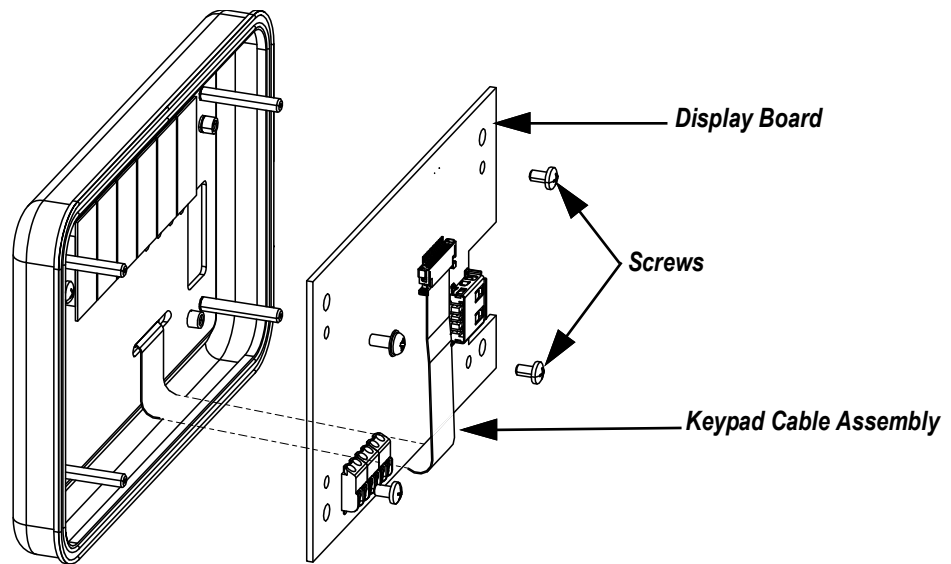

Figure 2-10. Display Board

6. To replace the display board, reverse the above procedure.

2.2.5 Board Replacement

If the 880 CPU board must be removed, use the following procedure:

1. Disconnect power to the indicator.
2. Unplug all connectors from the backplate, see [Figure 2-24 on page 36](#) for connector locations.
3. Remove the controller assembly from the DIN rail, and unplug the display cable harness, see [Section 2.2.2 on page 24](#).
4. Loosen the four corner screws and carefully pull the backplate straight out from the enclosure. The boards are still connected to the backplate and will slide out of the enclosure.



NOTE: Use caution when removing the boards, boards are fragile. All boards will slide out together; the power supply board and the CPU board are connected by a cable.

5. Remove the cable connecting the boards.

- Remove the board to be replaced by loosening the screws holding it to the backplate.

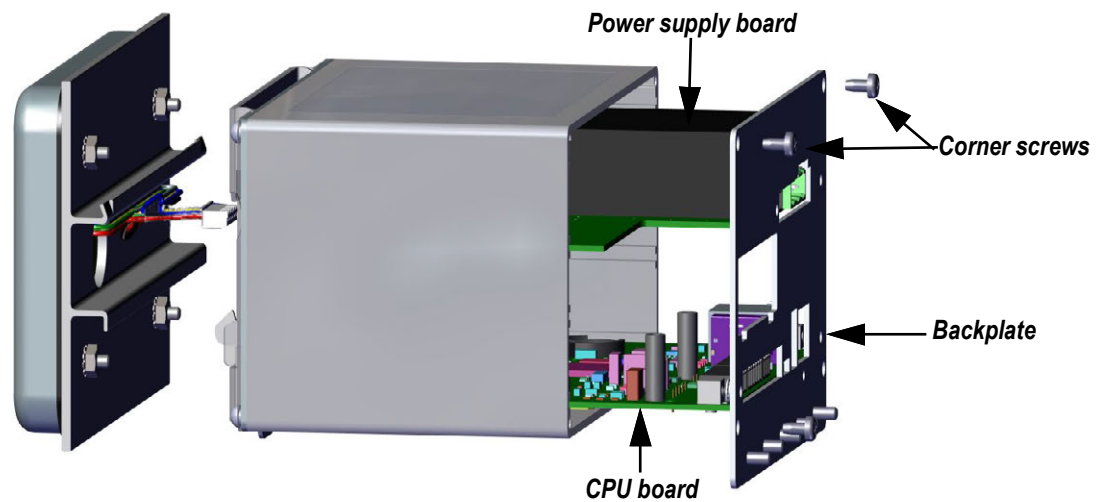

Figure 2-11. Boards Removed from Enclosure

- Place the new board in position and secure using the existing screws.
- Connect cable to boards.
- Slide backplate, with boards, into the enclosure. Ensure that each board is seated correctly in the grooves of the enclosure.



NOTE: Ensure the enclosure is in the upright position, otherwise the connector for the display will not align with the front cutout.

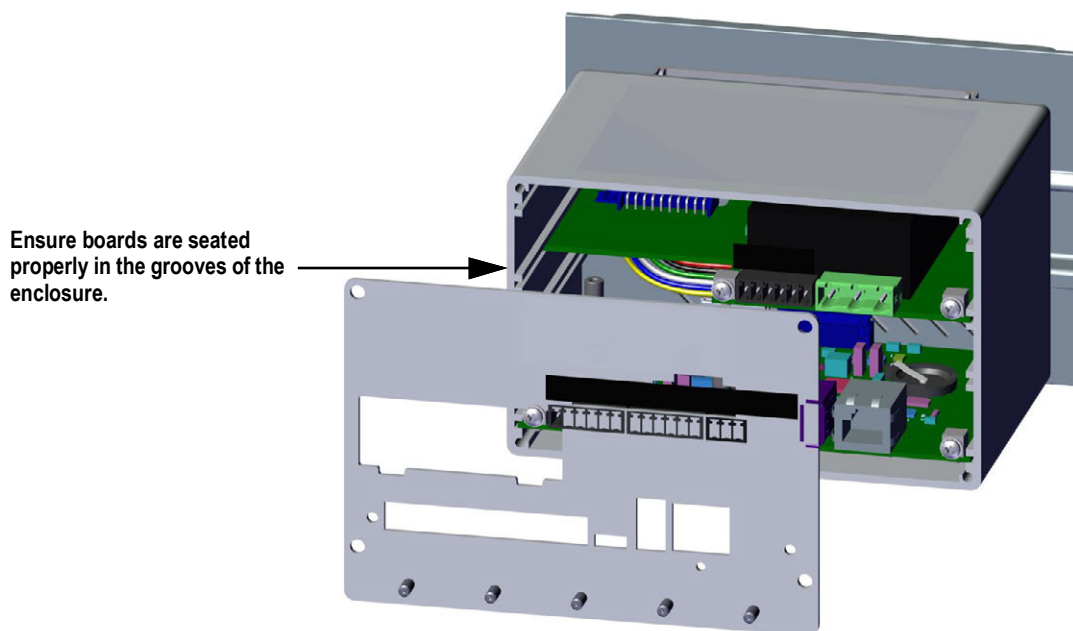

Figure 2-12. Boards Installed in Controller Assembly Enclosure

- Secure backplate to the enclosure using the four existing corner screws.
- Reinstall controller assembly, see [Step 4–Step 6](#) in [Section 2.2](#) on [page 20](#).
- Reconnect all connectors to the backplate, see [Figure 2-24](#) on [page 36](#) for connector locations.

2.3 Universal Mount Installation

The universal mount can be placed on a desk or counter, or mounted to a wall or panel using the stand included in with the indicator.

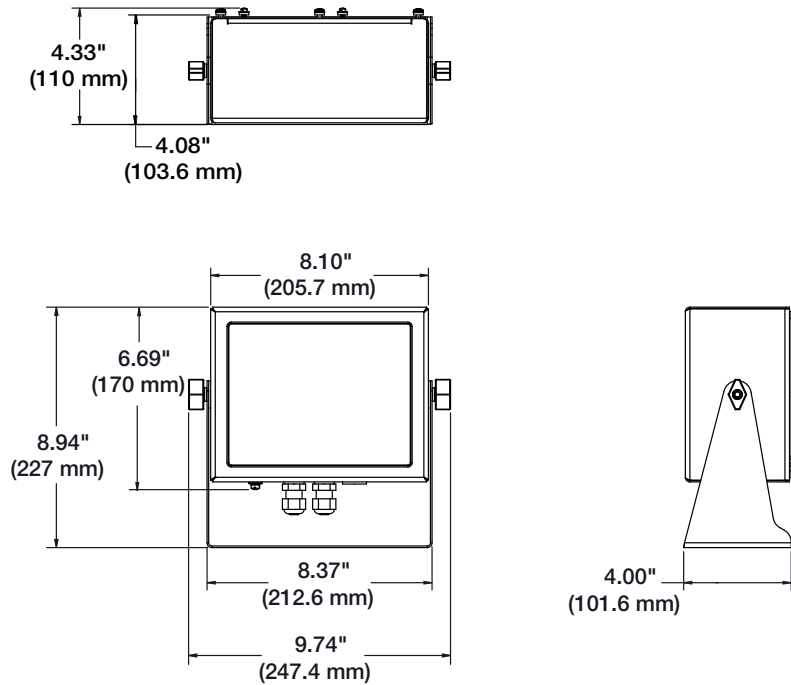

Figure 2-13. Universal Mount Dimensions

2.3.1 Remove Back Panel

Remove the backplate of the universal mount assembly to gain access to the display board, CPU board, power supply board, and any installed option card.

1. Remove the eight screws that attach the backplate to the enclosure.
2. Remove the backplate.

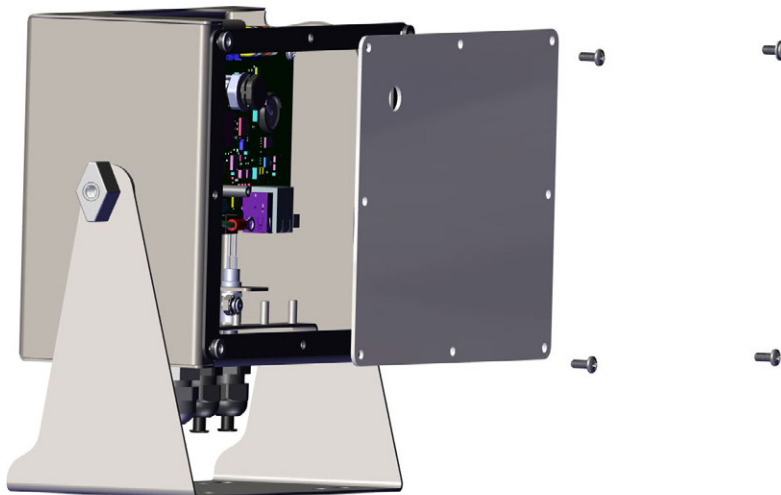

Figure 2-14. Remove Universal Mount Backplate



NOTE: The 880 ships with only four screws securing the backplate.



WARNING: Disconnect power to the indicator prior to removing any boards from the 880.

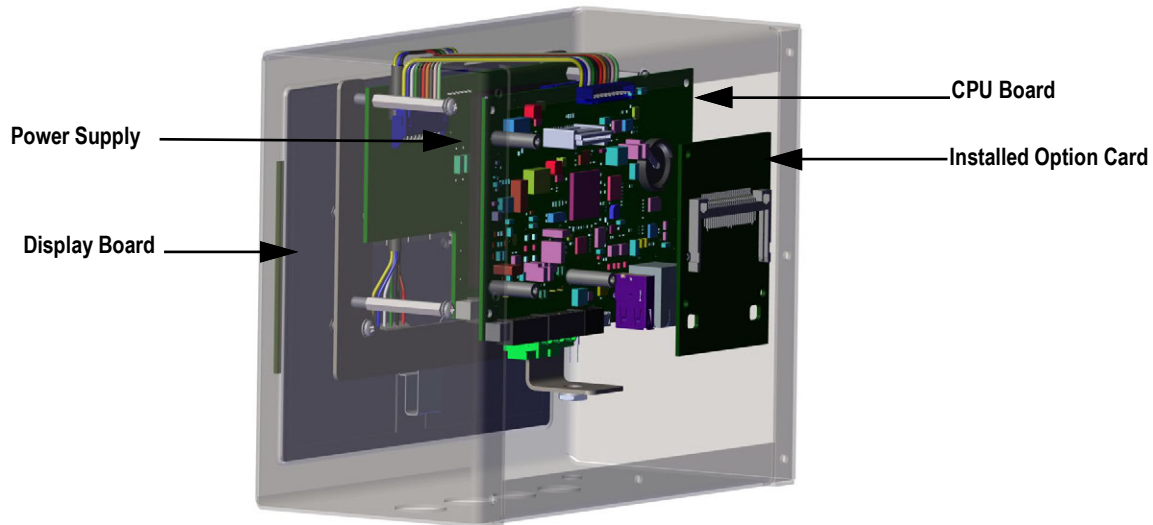

Figure 2-15. Board Locations in the Universal Mount

2.3.2 Board Replacement

1. Disconnect power to the indicator.
2. Remove the backplate from the enclosure, see [Section 2.3.1 on page 28](#).

 **NOTE:** Label connections for re-installation of board.

3. Remove installed option card (if applicable).
 - Disconnect all cables from the option card
 - Remove the three screws that attach the option card to the CPU board
 - Lift the card out of the enclosure
4. Disconnect all cables from the CPU board.
5. Remove the four screws from the CPU board.
6. Lift the CPU board out of the enclosure.

 **NOTE:** If only replacing CPU board, place the CPU board in place, secure with screws, reconnect all cables and reverse the above procedure to complete.

If replacing other boards, continue with [Step 7](#).

7. Disconnect all cables from the power supply.
8. Remove the three screws from the power supply.
9. Lift the power supply out of the enclosure.

 **NOTE:** If replacing the display board, continue with [Step 10](#).

10. Remove the four screws from the CPU mounting plate.
11. Lift the CPU mounting plate out of the enclosure.
12. Disconnect all cables from the display board.
13. Lift the display out of the enclosure.

To install the board, reverse the above procedure. Be sure to reinstall cable ties to secure all cables inside the indicator enclosure.

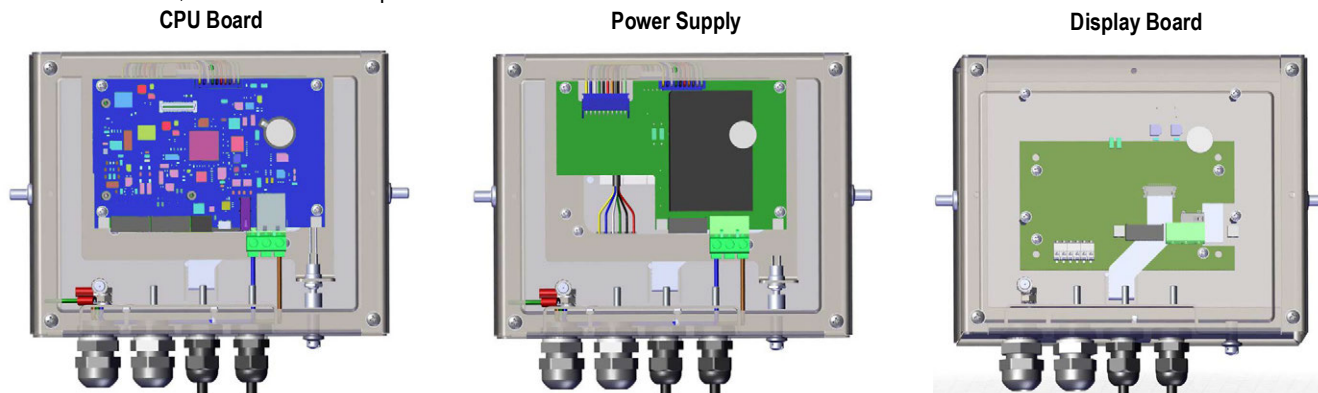

Figure 2-16. 880 Universal Mount Board Replacement

2.4 Cable Connections

The 880 Panel Mount has six external connectors, a power terminal connector and a cutout for an option card. Enclosure disassembly is not required to make connections to load cells, communications, digital I/O or option cards. These connectors are all externally mounted on the back of the controller.

The 880 Universal Mount has four cord grips at the bottom of the indicator, one is used for the power supply. Cable plugs must be installed in unused cord grips to prevent moisture from entering the enclosure. The backplate must be removed to make connections to load cells, communications, digital I/O or option cards, see [Section 2.3.1 on page 28](#).

IMPORTANT: Properly seal cord grips to prevent moisture damage inside of the enclosure. Cable plugs must be installed in unused cord grips. Cord grip dome nuts, around a cable or a plug, must be torqued to 22 in-lb. The cord grip nut against the enclosure must be torqued to 33 in-lb.

2.4.1 Cable Specifications

Cord Grip	Diameter Range
PG9 (PN 15626)	0.138 - 0.315" (3.5 - 8 mm)
PG11 (PN 68600)	0.197 - 0.394" (5 - 10 mm)

Table 2-2. Cord Grip Specifications

2.4.2 Load Cells

To attach cable from a load cell or junction box, route the cable to the J1 connector. Wire the load cell cable from the load cell or junction box to connector J1 as shown in [Table 2-3](#). If using 6-wire load cell cable (with sense wires), open the unit, see [Section 2.2 on page 20](#) and remove jumpers JP5 and JP6.

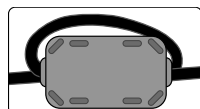

A ferrite from the parts kit must be applied to the load cell cable within 1 in of the cord grip. The cable must be sent through the ferrite twice.

NOTE: For 4-wire installation, leave jumpers JP5 and JP6 on, see [Figure 2-24 on page 36](#).

Pin	Function
1	+SIG
2	-SIG
3	+SENSE
4	-SENSE
5	+EXC
6	-EXC

Table 2-3. JP1 Pin Assignments

NOTE: For 6-wire load cell connections, remove jumpers JP5 and JP6. The shield wire will attach to the ground clamp on the backplate (panel mount) or bottom of enclosure (universal).

2.4.3 Power Connections – 880 Panel Mount

Power connections to the 880 Panel Mount are shown below. A 3-pin plug is used to connect AC power (PN 152334) or DC power (PN 15888) to the power supply board. Attach the wires as shown in [Figure 2-17](#).

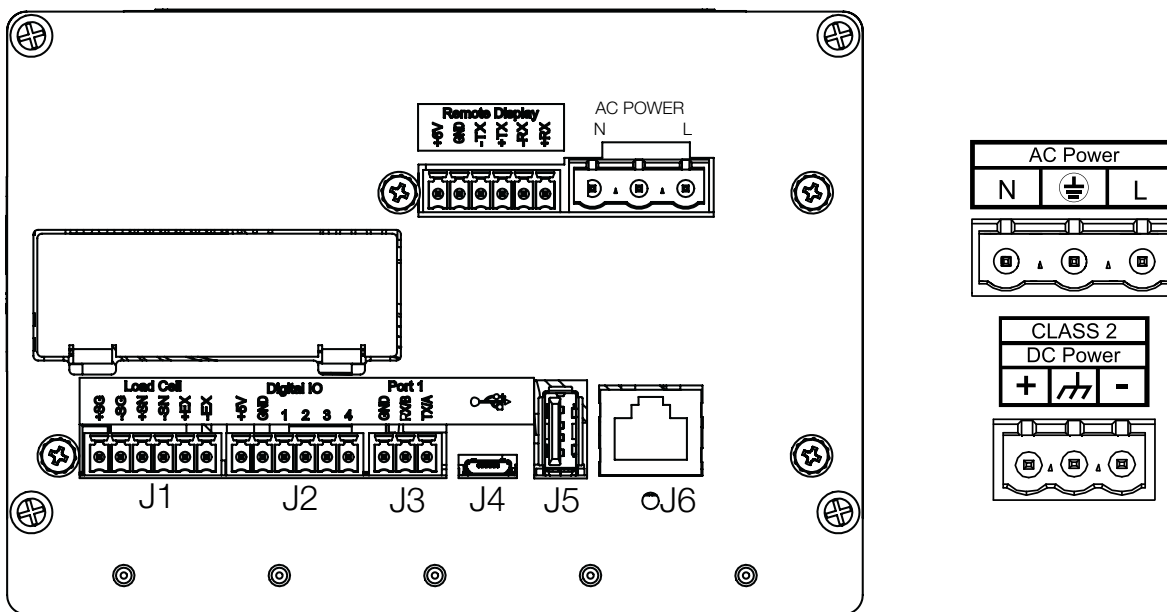

Figure 2-17. Power Connection Location

Pin	AC	DC
1	N	+
2	Chassis GND	Chassis GND
3	L	-

Table 2-4. Power Connection Pin Assignments

2.4.4 AC Cable Grounding in 880 Universal

Proper grounding must be done going to the power supply and the back plate of the indicator. Except for the power cord, all cables routed through cord grips should be grounded against the indicator enclosure, including the AC power cable. The AC versions of the 880 universal are shipped with the AC power cable already installed and grounded to the enclosure. The following procedure is provided for reference and possible replacement applications..

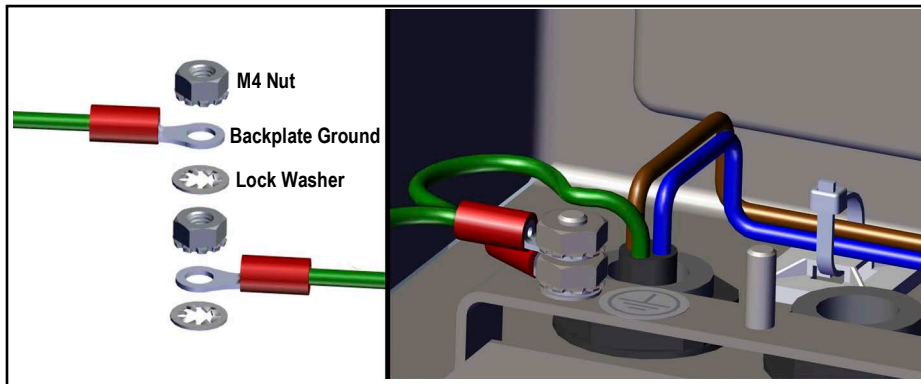

Figure 2-18. AC Grounding Stackup

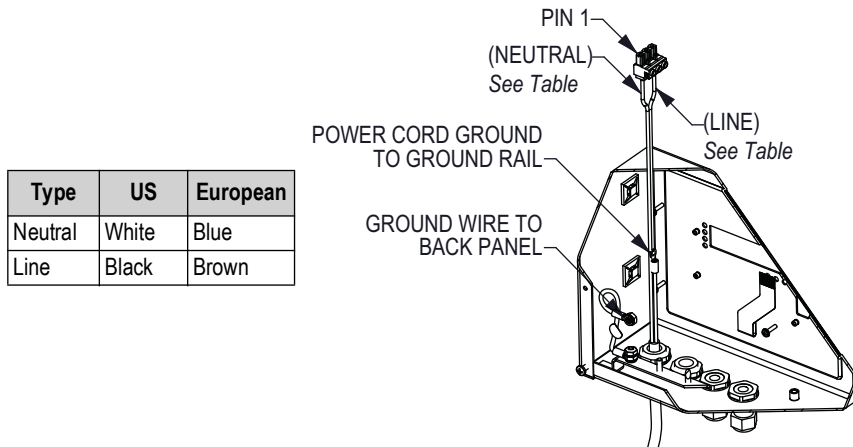

Figure 2-19. Grounding Bonds

1. Run the cable up through the cord grip (not included), see [Figure 2-20](#).

NOTE: 22-16 AWG wire (5-10 mm diameter) required.

2. One wire will be terminated (grounded) at a stud near the cord grip using the grounding stackup.
3. Run the other two wires down the back of the indicator and connect them to the three pin plug (PN 152334) that connects to the power supply board, see [Figure 2-20](#) and [Table 2-4 on page 31](#).

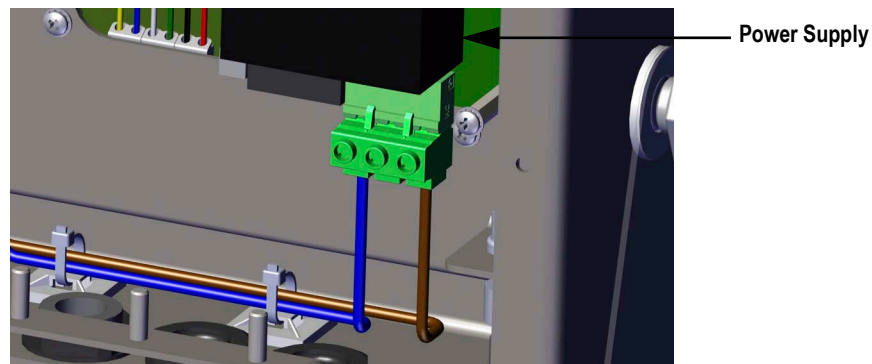

Figure 2-20. Connect AC Wiring

2.4.5 DC Cable Grounding in 880 Universal

Except for the power cord, all cables routed through cord grips should be grounded against the indicator enclosure, including the DC power cable. Do the following to ground DC power.

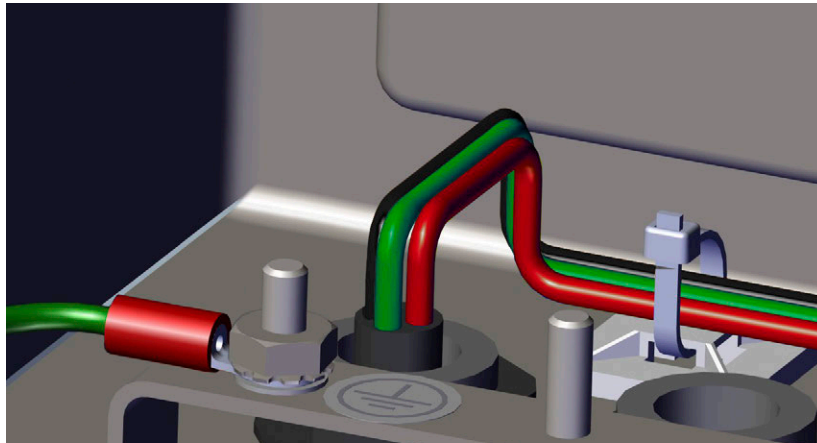

Figure 2-21. DC Power Cable Routing

1. Run the cable up through the cord grip, see [Figure 2-21](#).



NOTE: 22-16 AWG wire (5-10 mm diameter) required.

2. Run the three wires down the back of the indicator and connect them to the three pin plug (PN 15888) that connects to the power supply board, see [Figure 2-22](#) and [Table 2-4 on page 31](#).

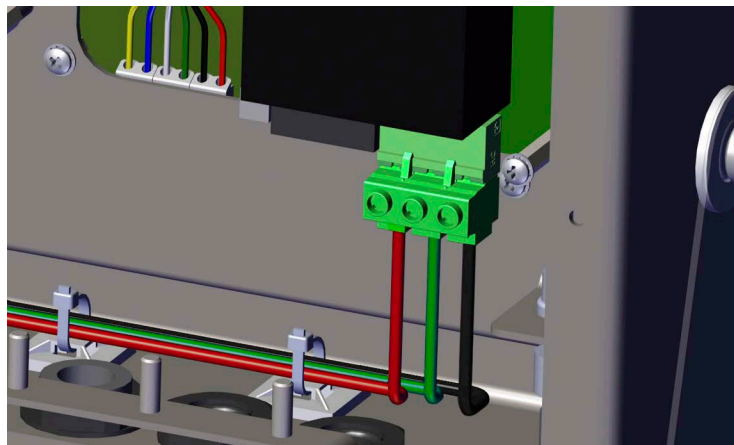

Figure 2-22. Connect DC Power Wiring

2.4.6 Serial Communications – Port 1 (COM)

Connector J3, see [Figure 2-17 on page 31](#), provides connections for the RS-232 or the two-wire RS-485/RS-422 serial communications, see [Table 2-5](#) for pin assignments.

Pin	RS-232	RS-485/RS-422
1	GND	GND
2	RX	B
3	TX	A

Table 2-5. J3 Pin Assignments (Port 1 Serial Communications)



NOTE: For RS-232, all four switches on SW3, see [Figure 2-23 on page 35](#) must be in the OFF position.

For RS-485/RS-422, all four switches on SW3 must be in the ON position.

2.4.7 Optional Dual Serial Expansion Card

The Dual Serial Expansion Card (PN 197347) provides two additional serial ports to the 880 that can connect with either RS-232, RS-485 or RS-422. [Table 2-6](#) shows the pin assignments.

J1	Port (x1)	J2	Port (x2)
Pin 1	GND	Pin 1	GND
Pin 2	RX/B	Pin 2	RX/B
Pin 3	TX/A	Pin 3	TX/A
Pin 4	CTS/Z	Pin 4	CTS/Z
Pin 5	RTS/Y	Pin 5	RTS/Y

Table 2-6. Pin Assignments for RS-232/RS-485

For more information, refer to the Dual Serial Option Card addendum, PN 200282.

2.4.8 USB Device Communications – Port 2 (USBCOM)

The USB Device Port (J4 micro USB connector, [Figure 2-17 on page 31](#)) is intended to be connected to a computer only. It will appear as a Virtual COM Port and be assigned a “COMx” designation. Applications will communicate through the port like a standard RS-232 communications port.

Before the USB Device Port can be used, drivers must be installed on the computer. With the computer and indicator powered on, connect a USB cable from the computer to the micro USB connector (J4) on the 880. The computer will recognize that a device has been connected, and will attempt to install the drivers needed to make it work. The drivers are included on the CD that was supplied with the indicator. The drivers can also be downloaded from the Rice Lake website.



NOTE: *If using Windows 7 or later, and the computer is connected to the Internet, the operating system may be able to install the drivers without any interaction.*

When the individual drivers are installed, a new COM Port designation is assigned for each physical USB port the 880 is connected to on the computer.

For example, if the computer already has two physical RS-232 COM Ports, they most likely are designated COM1 and COM2. When connecting the indicator to a USB port on the computer, it will be assigned the next available port designation, or in this case, COM3. When plugging into the same physical USB port on the computer, the port designation will again be COM3. If plugging into another physical USB port on the computer, it will be assigned the next available designation, in this case COM4.

After the drivers are installed, use Windows Device Manager to determine the COM Port designation that was assigned to the USB port. Or open the application that is to be used with the 880, such as Revolution[®], and see which ports are available.

Configuration of the USB Device Port is done in the USBCOM sub-menu under PORTS in configuration mode.

The port can be configured as either a demand port for EDP commands and printing, or a data streaming port. Other settings include the termination character(s); enabling echoes and responses; adjust the end-of-line delay; and whether or not the indicator displays a 'print' message when a print format sends data out the port.



NOTE: *If a computer application has an open communications connection through the USB Device Port, and the physical cable connection is interrupted, a soft reset is performed on the indicator or power is cycled to the indicator; the connection in the computer application must be disconnected and reconnected again before it will continue to communicate with the indicator.*

For the USB Device Port, it does not matter what the settings are for Baud, Data Bits, Parity and Stop Bits in the computer software. The port will communicate in the same way regardless of these settings.

This port is not a host port and is not intended to be connected to other devices such as keyboards, memory sticks or printers.

2.5 USB Host

The 880 can host a USB device through the Type A USB connection (J5), see [Figure 2-17 on page 31](#). Devices that are supported include USB keyboards and flash drives, see [Section 3.2.11 on page 59](#) for configuration.

For further information, see [Section 9.2 on page 105](#).

2.6 Ethernet Communications

The 880 features Ethernet TCP/IP 10Base-T/100Base-TX communication using a standard RJ45 connector (J6), see [Figure 2-17 on page 31](#). It can support two simultaneous connections, one as a server, the other as a client.

Through an Ethernet network, software applications are able to communicate with the 880 using the EDP command set, see [Section 6.0 on page 77](#), or data can be streamed continuously from the indicator, or printed on demand.

The Ethernet port supports both DHCP and manual configuration of settings such as the IP and subnet. In addition, the TCP Port number, Primary and Secondary DNS, and the Default Gateway can be configured using the Ethernet sub-menu of the Ports setup menu. For more information on configuring the Ethernet port, see [Section 3.2.10 on page 58](#).

Physical connection to the 880 Ethernet port can be made directly from a computer to the 880 (AdHoc Network), or through a network router or switch. The port supports auto-sensing MDI/MDIX cable configuration, so either straight-through or crossover cables can be used.

IMPORTANT: *If the indicator is on a network that has PoE capable Power Sourcing Equipment (PSE), the PSE must be IEEE 802.af or 802.2.at compliant. Any PSE that uses passive (always on) technology will damage the Ethernet port, because it is not designed to act as an Ethernet PoE Powered Device.*

The RJ45 Ethernet jack on the 880 houses two LEDs to indicate the status and speed of the connection.

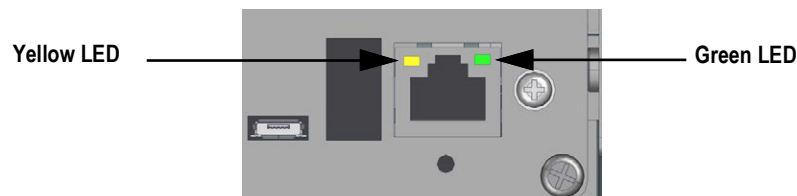

Figure 2-23. RJ45 Ethernet Jack – Panel Mount

Yellow LED (left) indicates the status of the connection:

- Off for no link
- On for a link
- Blinking if there is activity

Green LED (right) is:

- Off for a 10Base-T connection
- On for a 100Base-TX connection

IMPORTANT: *The Ethernet port is not intended for use on Telecom Networks Circuits that are subject to lightning or power faults. For information on using the Ethernet port, see [Section 9.1 on page 101](#).*

2.7 CPU Board (175109 - Blue)

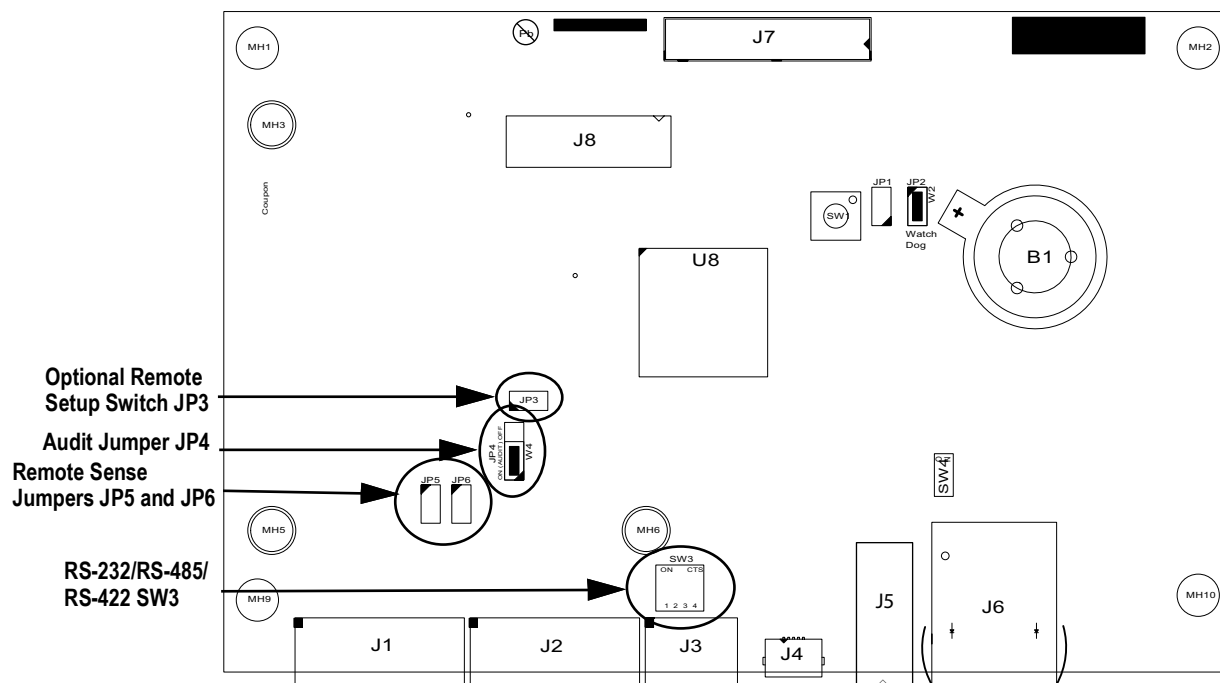



Figure 2-24. 880 CPU Board

Port	Connector
J1	Load cell
J2	I/O
J3	Comm 1
J4	USB Device
J5	USB Host
J6	Ethernet TCP/IP
J7	Power Board
J8	Option Header



Table 2-7. CPU Board Connectors

The COMM 1 port supports RS-232 or two-wire RS-485/RS-422 communications; selectable with switch SW3. The port is configured using the COM menu under Ports, see [Section 3.0 on page 44](#).

2.8 Audit Trail

The 880 audit trail tracks the number of times changes have been made and saved for configuration and calibration. The time and date is also retained for the last change for both calibration and configuration. It is possible to setup the 880 to allow entry to the configuration and calibration menus using only the front panel .

The 3-pin jumper (JP4), enables or disables the audit trail feature. See [Figure 2-1 on page 20](#).

- To use the audit trail and allow the use of  to enter the configuration mode, place the jumper in the On position
- To prevent the use of the  to enter the configuration and calibration mode, instead requiring use of the externally seal-able setup switch located inside the enclosure, see [Figure 3-1 on page 44](#), place the jumper in the Off position

The audit trail counters will operate in either position of the audit jumper.

2.9 Digital I/O

Digital inputs can be set to provide many indicator functions, including all keypad functions except MENU. Digital inputs are active low (0 VDC) and inactive high (5 VDC). Use the Digital I/O menu to configure the digital inputs.

Digital outputs are typically used to control relays that drive other equipment. Outputs are designed to sink, rather than source, switching current. Each output is a normally open collector circuit, capable of sinking 20 mA when active. Digital outputs are active when low or at 0 VDC, with reference to the 5 VDC supply.

Use the Digital I/O menu to set the function of the Digital I/O pins to OUTPUT, then use the Setpoints menu to configure the digital outputs.

Table 2-8 shows the pin assignments for connector J2.

Connector	Pin	Signal
J2	1	5VDC, 500mA max
	2	GND
	3	DIO1
	4	DIO2
	5	DIO3
	6	DIO4

Table 2-8. J2 Pin Assignments (Digital I/O)

2.10 Legal for Trade Sealing

In certain Legal for Trade applications, it may be necessary to seal the indicator to restrict access to the setup switch.

2.10.1 880 Panel Mount Sealing

An optional sealing kit (PN 153660) is available for Legal for Trade units. Sealing wire is not included within optional the sealing kit.

Part No.	Part	QTY
158402	Load Cell Locking Clip	1
158207	6-32 x 1/4" Fillister Head Screw	4

Table 2-9. Optional Sealing Kit Parts List

1. Remove the screw highlighted in Figure 2-25.

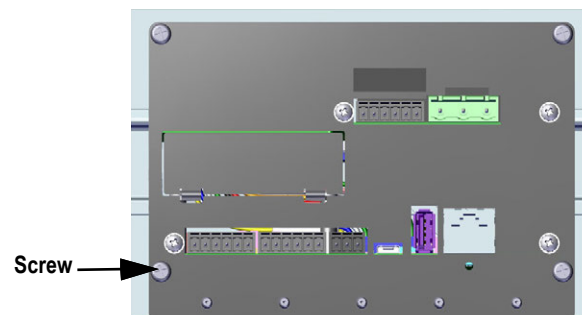

Figure 2-25. Bottom Plate Screw

2. Slide the load cell sealing clip over the load cell connector.

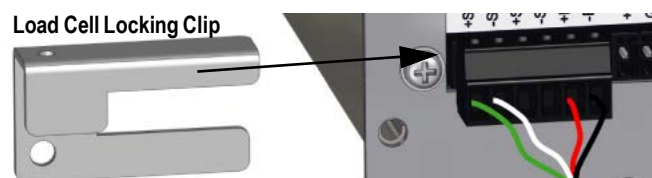

Figure 2-26. Secure Load Cell Locking Clip

3. Replace the removed screw with a fillister head screw found in the sealing kit.
4. Install another fillister screw into the setup switch hole.

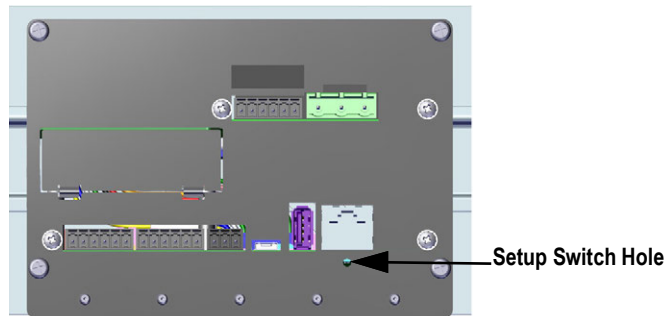

Figure 2-27. Setup and Configuration Switch Hole

5. Replace the two screws on the DIN rail bracket with the two remaining screws from the sealing kit.



NOTE: If required, a provision of fillister screws are provided to properly seal the unit.

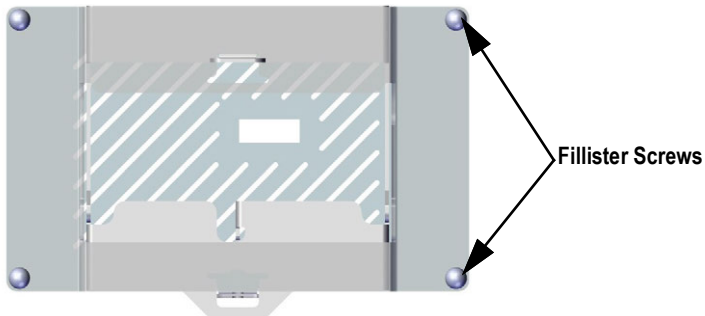

Figure 2-28. DIN Rail Bracket Screw Locations

6. Thread the sealing wire through two of the fillister screws and the installed clip.



Figure 2-29. Install Sealing Wire

2.10.2 880 Universal Mount Sealing

1. Place the sealing wire through the fillister head screws on the back panel, then through the fillister head screw at the bottom of the indicator.
2. Seal the wire to secure.

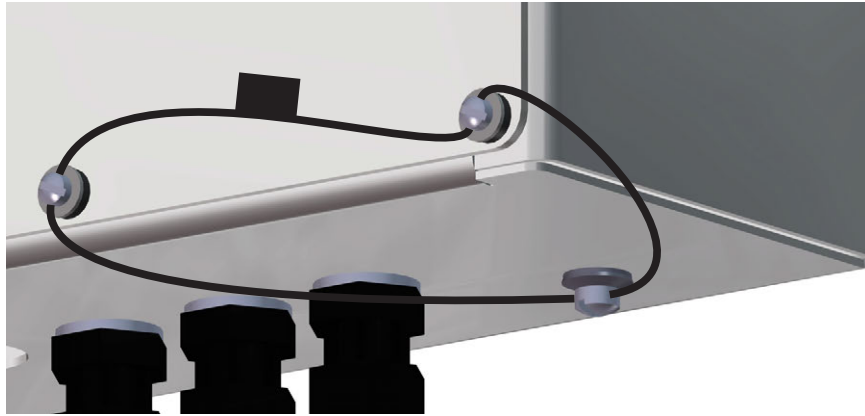

Figure 2-30. Sealing the Universal Mount

2.11 Option Cards

Connector J8 is reserved for option cards. [Table 2-10](#) lists the options available for the 880 Indicator. Each kit includes instructions for installing and setting up the option card..

Option Part No.	Option	Addendum Part No.
179156	Analog Output Card	200273
179157	Relay Card	200274
179158	EtherCat	200275
179159	EtherNet/IP	200276
179160	ProfiNet	200277
179161	Modbus TCP	200278
179162	DeviceNet	200279
179163	Profibus DP	200280
197343	Digital I/O Card	200281
197347	Serial Card	200282

Table 2-10. Available 880 Option Cards

2.12 Battery Replacement

When battery voltage depletes to 2.9 VDC, the indicator display shows **low bat**. Replace the battery when this warning is displayed to prevent data loss in the event of a power failure. The battery life will vary depending on use. It is recommended to replace the battery every three years if left powered off for extended periods of time.

Use the Revolution configuration utility or EDP commands, see [Section 6.1 on page 77](#) to store a copy of the indicator configuration on a computer before attempting battery replacement. If any data is lost, the indicator configuration can be restored from the computer.



WARNING: Risk of explosion if battery is replaced by an incorrect type. Dispose of used batteries according to state and local regulations.

2.13 Panel Mount Replacement Parts

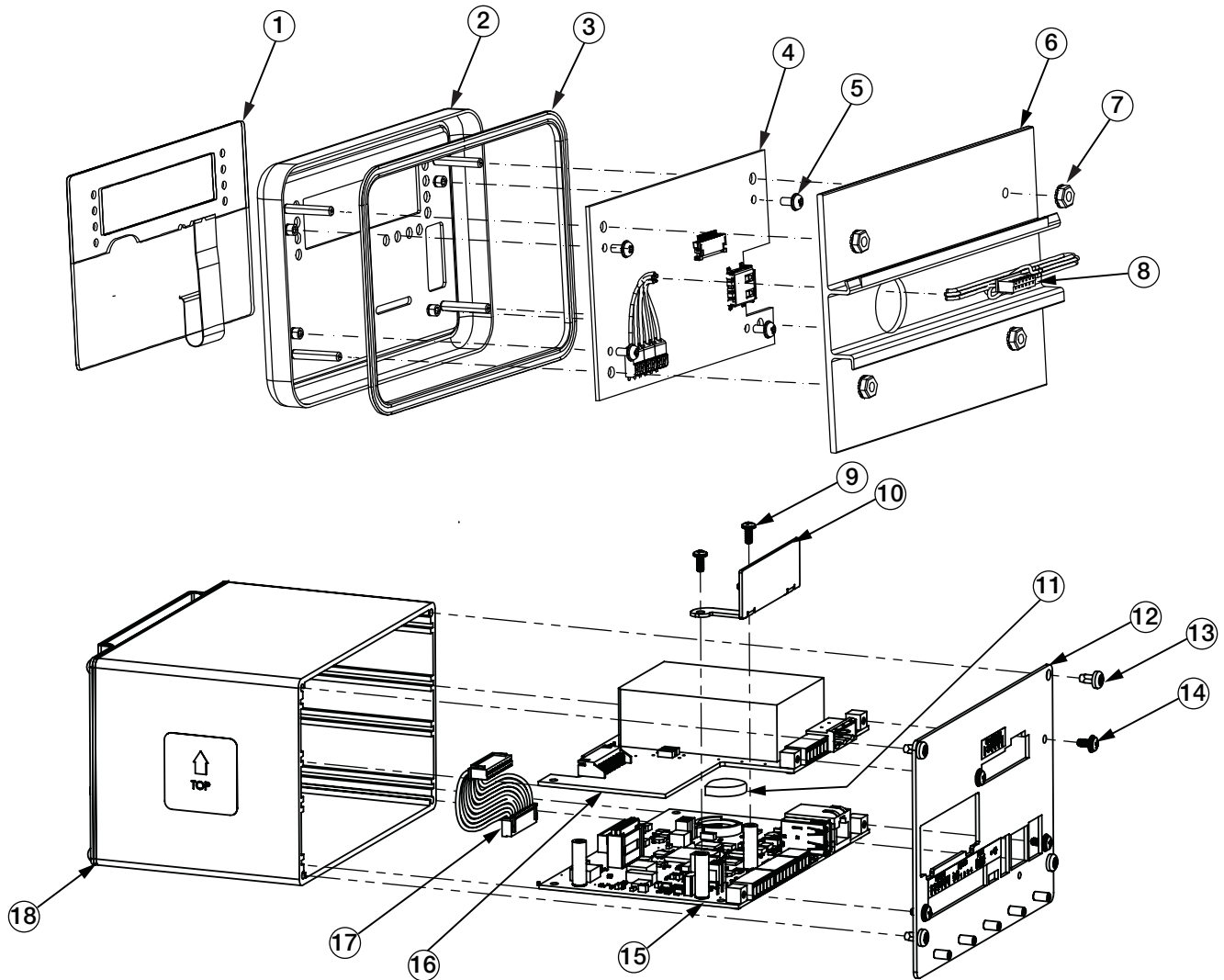

Figure 2-31. Panel Mount Parts Illustration

Item No.	Part No.	Description	Qty.
--	151674	Display Assembly, 880 Panel Mount (includes items 1-8)	Ref
1	131740	Overlay, Membrane Switch	1
2	151663	Faceplate, Display	1
3	151667	Gasket, Faceplate	1
4	131598	Board Assembly, LED Display	1
5	14822	Screw, Mach 4-40NC x 1/4	4
6	156439	Display Backplate with DIN Rail	1
7	14621	Nut, Kep 6-32NC HEX	4
8	151668	Cable Assembly, Controller to Display	1
--	177977	Controller, 880 Panel Mount (Includes Items 9-18)	Ref
9	14822	Screw, Mach 4-40NC x 1/4	2
10	179641	Face Plate, Slot Cover	1
11	69291	Battery, 3 V Coin Lithium	1
12	177290	Backplate Assembly	1
13	153856	Screw, Mach 6-32NC x1/4	4
14	14822	Screw, Mach 4-40NC x 1/4	4
15	175109	Board Assembly, CPU 5.5", Blue Color	1
16	175603	Power Supply, AC Power, 5.5"	1
	175604	Power Supply, DC Power, 5.5"	
17	154762	Cable Assembly, Power Supply to CPU	1
18	179640	Enclosure Assembly	1

Table 2-11. Panel Mount Replacement Parts

2.13.1 Panel Mount Parts Kits

Part No.	Description	Qty.
14621	Nut, Kep 6-32NC Hex	5
15130	Washer, Lock No. 6 Type A	5
152334	Conn, 3 Pos Screw Terminal	1
153873	Conn, 3 Pos Screw Terminal	1
153883	Conn, 6 Pos Screw Terminal	3
157074	Ferrite, EMI/RFI Clamp-on	1
53075	Clamp, Ground Cable Shield	4
67550	Clamp, Ground Cable Shield	1
94422	Label, Capacity 40 x 5.00	1

Table 2-12. Parts Kit AC Power (PN 152235)

Part No.	Description	Qty.
14621	Nut, Kep 6-32NC Hex	5
15130	Washer, Lock No. 6 Type A	5
15888	Terminal Block, 3 Pos	1
153873	Conn, 3 Position Screw Terminal	1
153883	Conn, 6 Position Screw Terminal	3
157074	Ferrite, EMI/RFI Clamp-on	1
53075	Clamp, Ground Cable Shield	4
67550	Clamp, Ground Cable Shield	1
94422	Label, Capacity .40 x 5.00	1

Table 2-13. Parts Kit DC Power (PN 153647)

2.14 Universal Mount Replacement Parts

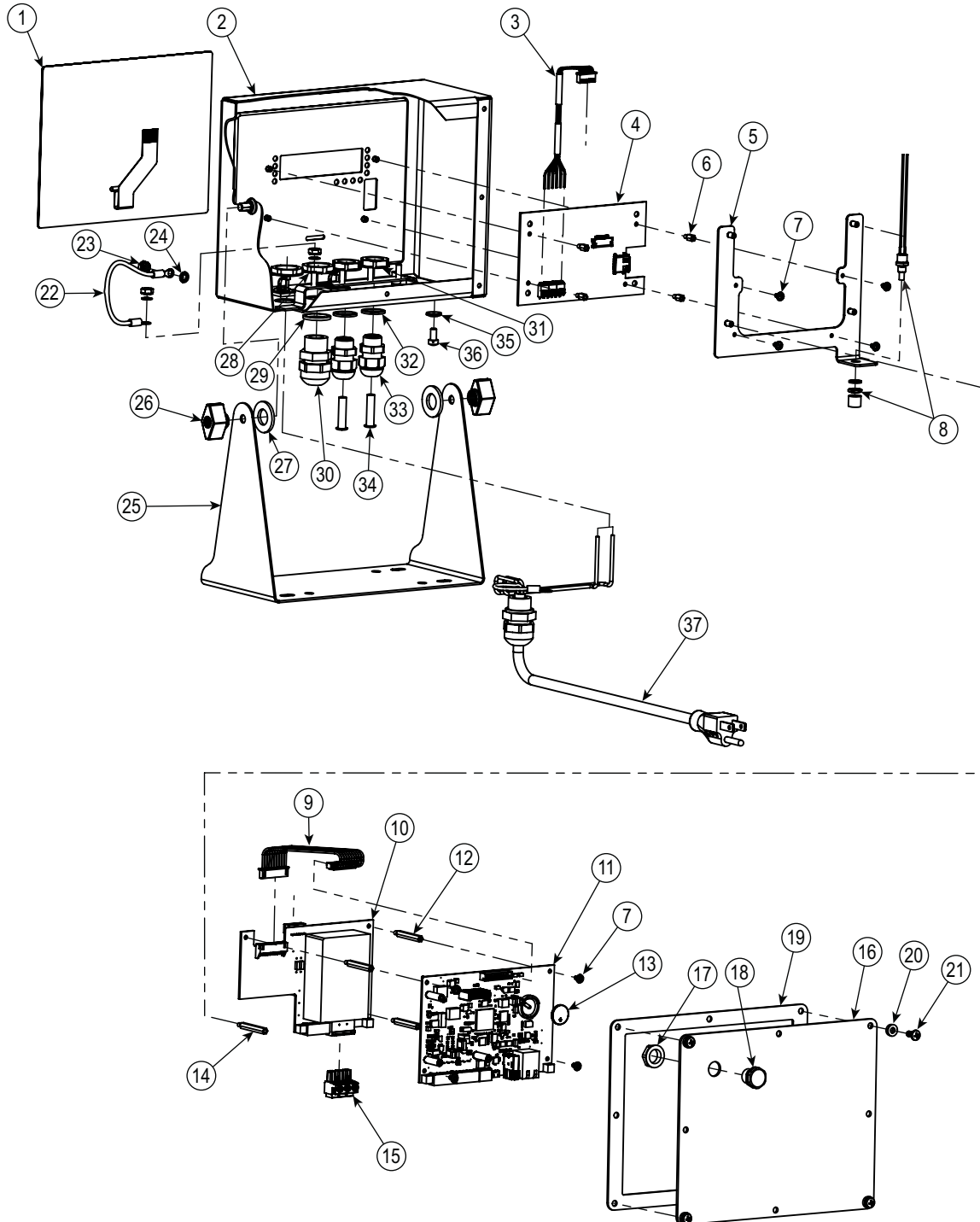

Figure 2-32. Universal Mount Parts Illustration



IMPORTANT: Properly seal cord grips to prevent moisture damage inside of the enclosure. Cable plugs must be installed in unused cord grips. Cord grip dome nuts, around a cable or a plug, must be torqued to 22 in-lb. The cord grip nut against the enclosure must be torqued to 33 in-lb.

Item No.	Part No.	Description	Qty.	Item No.	Part No.	Description	Qty.
1	163986	Overlay, Membrane Switch	1	19	163768	Gasket	1
2	163752	Enclosure	1	20	45042	Washer, Bonded Sealing #6 3/8	4
3	151668	Cable Assembly, Controller to Display	1	21	14862	Screw, 8-32x3/8 Phillips Pan Head	4
4	131598	Board Assembly, LED Display	1	22	15601	Ground Wire	1
5	177361	Plate Mount	1	23	14626	Nut, Kep #8-32 Ext. Tooth Lockwasher	3
6	182290	Standoff, M-F 4-40x1/4	4	24	15134	Washer, Lock No. 8 Internal Tooth	3
7	14822	Screw, 4-40 X 1/4	8	25	163751	Tilt Stand	1
8	44845	Setup Switch Assembly	1	26	103610	Knob, Black 1/4-20	2
9	154762	Cable Assembly, CPU to Power Supply	1	27	103988	Washer, Nylon 0.515-0.52	2
10	175603	Board Assembly, AC Power	1	28	68601	Nut, PG-11	2
	175604	Board Assembly, DC Power		29	68599	Seal Ring, PG-11	2
11	175109	Board Assembly, CPU	1	30	68600	Cord Grip, PG-11	2
12	182452	Standoff, M-F 4-40x1-3/16	3	31	15627	Nut, PG-9	2
13	69291	Battery, Lithium Ion	1	32	30375	Seal Ring, PG-9	2
14	67885	Standoff, M-F 4-40x1-1/4	1	33	15626	Cord Grip, PG-9	2
15	152334	Connector, 3-Pos Screw Terminal AC	1	34	19538	Post Plug, Slotted Stem, 1/4 x 1	2
	15888	Connector, 3-Pos Screw Terminal DC		35	46381	Washer, #10 Bonded Sealing	1
16	163753	Backplate	1	36	14877	Screw, #10-32 X 3/8 Drilled Head	1
17	88734	Nut, M12x1	1	37	165343	Power Cord Assembly US	1
18	88733	Vent, Breather Sealed GORTEX	1		165402	Power Cord Assembly EU	

Table 2-14. Universal Mount Replacement Parts

Universal Mount Parts Kits

Part No.	Description	Qty.
14626	Kep Nut, 8-32 Hex	3
14862	Screw, 8-32 x 3/8	2
153873	Connector, 3-Position Screw Terminal	1
153883	Connector, 6-Position Screw Terminal	3
15631	Cable tie, 3 in Nylon	3
30623	Screw, 8-32 x 7/16, Drilled Head	2
42149	Rubber Grommet Bumper	4
45042	Washer, Bonded Sealing #6	4
53075	Clamp, Ground Cable Shield	3

Table 2-15. Parts Kit AC Power (PN 164147)





Part No.	Description	Qty.
14626	Kep Nut, 8-32 Hex	3
14862	Screw, 8-32 x 3/8	2
153873	Connector, 3-Position Screw Terminal	1
153883	Connector, 6-Position Screw Terminal	3
15631	Cable tie, 3 in Nylon	3
15694	Connector, Eye Crimp #8	1
15888	Terminal Block, 3-Position	1
30623	Screw, 8-32 x 7/16, Drilled Head	2
42149	Rubber Grommet Bumper	4
45042	Washer, Bonded Sealing #6	4
53075	Clamp, Ground Cable Shield	3

Table 2-16. Parts Kit DC Power (PN 181964)

3.0 Configuration

To configure the 880 indicator, the indicator must be placed in configuration mode. The setup switch is accessed through a small hole on the enclosure, see [Figure 3-1](#). The setup switch access hole is located on the backplate for the panel mount, and from the bottom of the enclosure on the universal model. Insert a non-conductive tool into the access hole and press the setup switch.

IMPORTANT: Use caution when inserting the non-conductive tool into the backplate, press the tool in about 3/4 inch, using the board as a guide, until the switch is engaged (a gentle click will be felt). Do not use excessive force that may damage the switch.

NOTE: If the audit trail is enabled, configuration mode may be accessed by pressing . Press  or  until Setup is displayed, then press  to Scale, see [Section 2.10 on page 37](#).

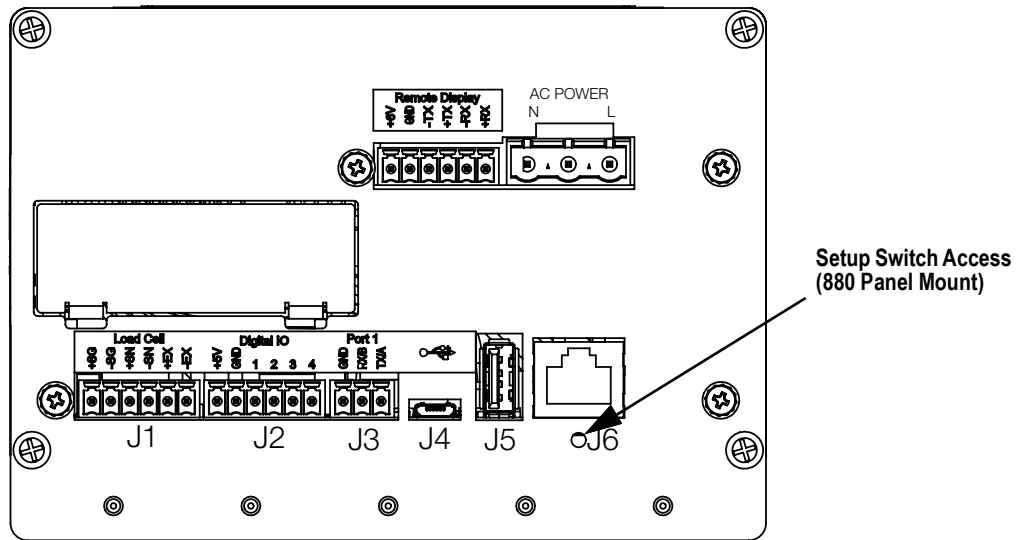

Figure 3-1. Back View – Setup Switch Access

NOTE: Setup switch access for the 880 Universal Mount is located at the bottom of the enclosure next to the cord grips.

When the indicator is placed in configuration mode, the word **Scale** displays. The SCALE menu is the first of eight top-level menus used for configuring the indicator. Detailed descriptions of these menus are given in [Section 3.2 on page 45](#).

When configuration is complete, press  to return to the weigh mode.

3.1 Configuration Methods

The 880 indicator can be configured by using the front panel keys to navigate through a series of configuration menus or by sending commands or configuration data to any data communication port. Configuration using the menus is described in [Section 3.2 on page 45](#).

Configuration using a data communication port can be accomplished using either the EDP command set, see [Section 6.0 on page 77](#) or the Revolution configuration utility, see [Section 5.2 on page 74](#).

3.2 User Setup Menu

The 880 indicator can be configured using a series of menus accessed through the front panel when the indicator is in user setup mode or configuration mode. [Table 3-1](#) summarizes the functions of the user setup menu.

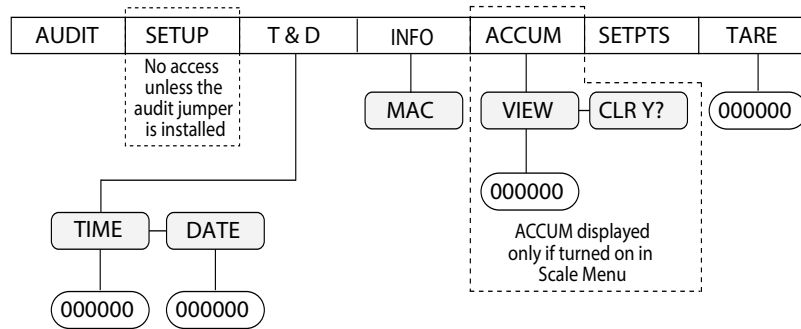

Figure 3-2. 880 Menu Layout

Menu		User Menu Function
AUDIT	Audit Trail	Displays the legally relevant (LR) firmware version, configuration count and calibration count, see Figure 3-3
SETUP	Setup	Used to enter configuration mode, if audit trail is enabled, see Figure 3-4 on page 46
T&D	Time and Date	View and change time and date
INFO	Information	View read only information about the indicator, such as Ethernet MAC ID
ACCUM	Accumulator	View, print or clear the current accumulator value, if enabled
SETPTS	Setpoints	Configure setpoint values and Enable/Disable setpoints; only configured setpoints will be available, see Figure 3-17 on page 62
TARE	Tare	View the current tare value

Table 3-1. 880 Menu Summary

The following sections provide graphic representations of the 880 menu structures. In the actual menu structure, the settings under each parameter are arranged horizontally. To save page space, menu choices are shown in vertical columns. The factory default setting appears at the top of each column in bold letters. Parameters shown surrounded by a dotted-line box only appear under the special circumstances explained under each box.

Most menu diagrams are accompanied by one or more tables that describe all parameters and parameter values associated with that menu option.

3.2.1 Audit Menu

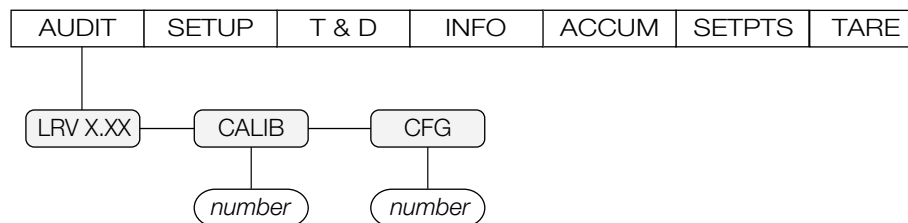

Figure 3-3. Audit Menu Structure

Parameter	Description
LRV	Legally relevant firmware version
CALIB	Displays total calibration events (read only)
CFG	Displays total configuration events (read only)

Table 3-2. Audit Menu Parameters

3.2.2 Setup Menu

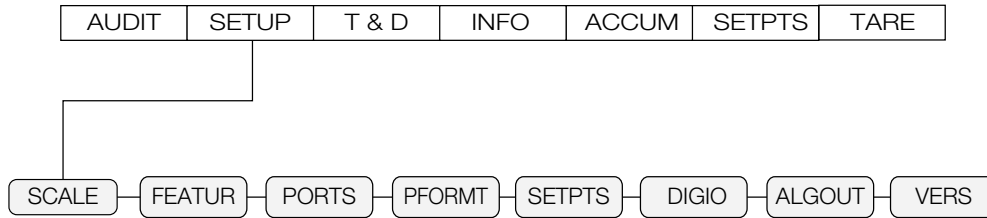

Figure 3-4. Setup Menu Structure

Menu	Description
SCALE	Configure and calibrate the scale, see Figure 3-5 on page 46 for the Scale menu structure
FEATUR	Set miscellaneous system attributes, see Figure 3-9 on page 51 for the Feature menu structure
PORTS	Configure communication ports, see Figure 3-11 on page 55 for the Ports menu structure
PFORMT	Set the print format used for header, gross, net and setpoint print formats, see Figure 3-16 on page 61 for the Print Format menu structure
SETPTS	Configure setpoints and batching mode, see Figure 3-17 on page 62 for the Setpoint menu structure
DIGIO	Assign digital input/output functions, see Figure 3-22 on page 67 for the Digital I/O menu structure
ALGOUT	Configure the analog output module, see Figure 3-23 on page 68 for the Analog Output menu structure
VERS	Displays installed firmware version; option to reset configuration to default values; see Figure 3-21 on page 66 for the Version menu structure

Table 3-3. Setup Menu Parameters

3.2.3 Scale Menu

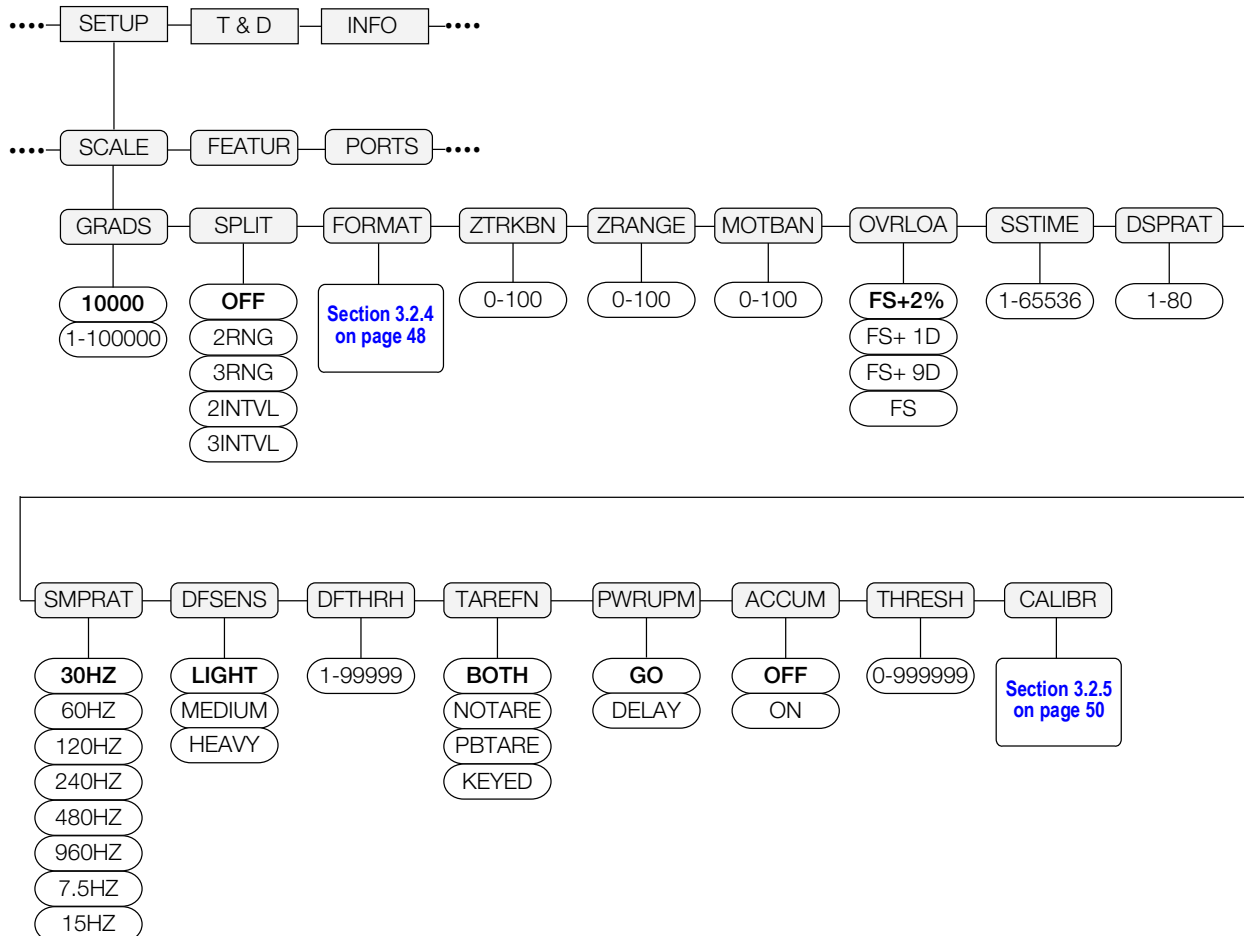

Figure 3-5. Scale Menu Structure

Parameter	Choices	Description
GRADS	10000 1–100000	Specifies the number of full scale graduations if SPLIT=OFF (for multi-range and multi-interval scales SPLIT is not Off but the GRADS value is derived from the capacity and display divisions specified for the range or interval); the value entered must be in the range 1–100000 and should be consistent with legal requirements and environmental limits on system resolution; to calculate GRADS, use the formula: $GRADS = Capacity / Display Divisions$; display divisions are specified under the FORMAT submenu
SPLIT	OFF 2RNG 3RNG 2INTVL 3INTVL	Specifies whether the scale is full-range (OFF), multi-range (2RNG, 3RNG), or multi-interval (2INTVL, 3INTVL); for multi-range and multi-interval scales, see the submenu shown in Section 3.2.4 on page 48 and parameter descriptions in Table 3-5 on page 49 .
FORMAT	Primary Format	See Section 3.2.4 on page 48 for menu structures; for standard scales see "If SPLIT = OFF", for multi-range/interval scales see "If SPLIT = 2RNG, 3RNG, 2INTVL, or 3INTVL"
ZTRBAN	0 0.0–100	Automatically zeros the scale when within the range specified, as long as the input is within the ZRANGE and scale is at standstill; specify the zero tracking band in \pm display divisions; the maximum legal value varies depending on local regulations
ZRANGE	1.900000 0.0–100	Selects the range within which the scale can be zeroed; the 1.900000 default value is $\pm 1.9\%$ around the calibrated zero point, for a total range of 3.8%. Indicator must be at standstill to zero the scale; maximum legal value varies depending on local regulations
MOTBAN	1 0–100	Motion Band – sets the level, in display divisions, at which scale motion is detected.; if motion is not detected for the time defined by the standstill parameter, the standstill symbol lights; some operations, including print, tare, and zero, require the scale to be at standstill; maximum legal value varies depending on local regulations; if this parameter is set to 0 the standstill annunciator is always lit; operations normally requiring standstill (zero, tare, print) are performed regardless of scale motion; if 0 is selected, ZTRKBN must also be set to 0
OVRLOA	FS+2% FS+1D FS+9D FS	Overload – determines the point at which the display blanks and an out-of-range error message is displayed; maximum legal value varies depending on local regulations
SSTIME	10 1–65535	Standstill Time – specifies the length of time the scale must be out of motion, in 0.1-second intervals, before the scale is considered to be at standstill
DSPRAT	1 1–80	Display update rate – specifies display update rate, in the number of 100-millisecond intervals between updates
SMPRAT	30HZ 60HZ 120HZ 240HZ 480HZ 960HZ 7.5HZ 15HZ	Sample rate – selects measurement rate, in samples per second, of the analog-to-digital converter; lower sample rate values provide greater signal noise immunity; settings of 120 Hz or above may be too fast to provide the desired stability in some static weighing applications
DFSENS	LIGHT MEDIUM HEAVY	Digital filtering sensitivity – the amount of influence the current A/D cycle has on the running averaged value; the Light setting will respond quicker to an applied weight to immediately impact the displayed value; Medium and Heavy settings are for applications where weighing times are longer and expected weight changes are larger
DFTHRH	0 0–99999	Digital filter cutout threshold – controls the response of the filter and must be set above the noise disturbances in the system; value is in grads; if set to zero there is no filtering, see Section 10.10 on page 118
TAREFN	BOTH NOTARE PBTARE KEYED	Tare function – enables or disables push-button and keyed tare; BOTH – both push-button and keyed tares are enabled; NOTARE – no tare allowed (gross mode only); PBTARE – push-button tares enabled; KEYED – keyed tare enabled
PWRUPM	GO DELAY	Power up mode; GO - in GO mode, the indicator goes into operation immediately after a brief power up display test; DELAY - the indicator performs a power up display test, then enters a 30-second warm up period; if no motion is detected during the warm up period, the indicator becomes operational when the warm up period ends; if motion is detected, the delay timer is reset and the warm up period repeated

Table 3-4. Scale Menu Parameters

Parameter	Choices	Description
ACCUM	OFF ON	Accumulator – specifies if the scale accumulator is enabled or disabled; if enabled, accumulation occurs every time a print operation is performed, while the weight is above the accumulator reset threshold, as long as the weight returns to a value lower than the threshold between print operations
THRESH	0 0–999999	Accumulator Reset Threshold – when the weight falls below the value set, the accumulator is rearmed
CALIBR	WZERO WVAL WSPAN WLIN REZERO LAST TEMP	Calibration – See Figure 3-8 on page 50 for descriptions and Section 4.0 on page 69 for calibration procedures

Table 3-4. Scale Menu Parameters (Continued)

3.2.4 Format Menu

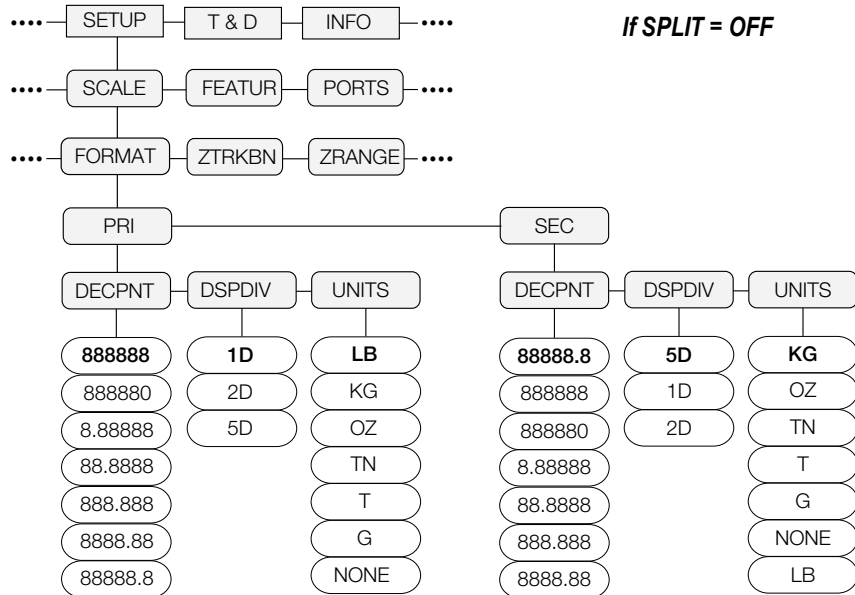

Figure 3-6. Format Menu Structure With Split Off

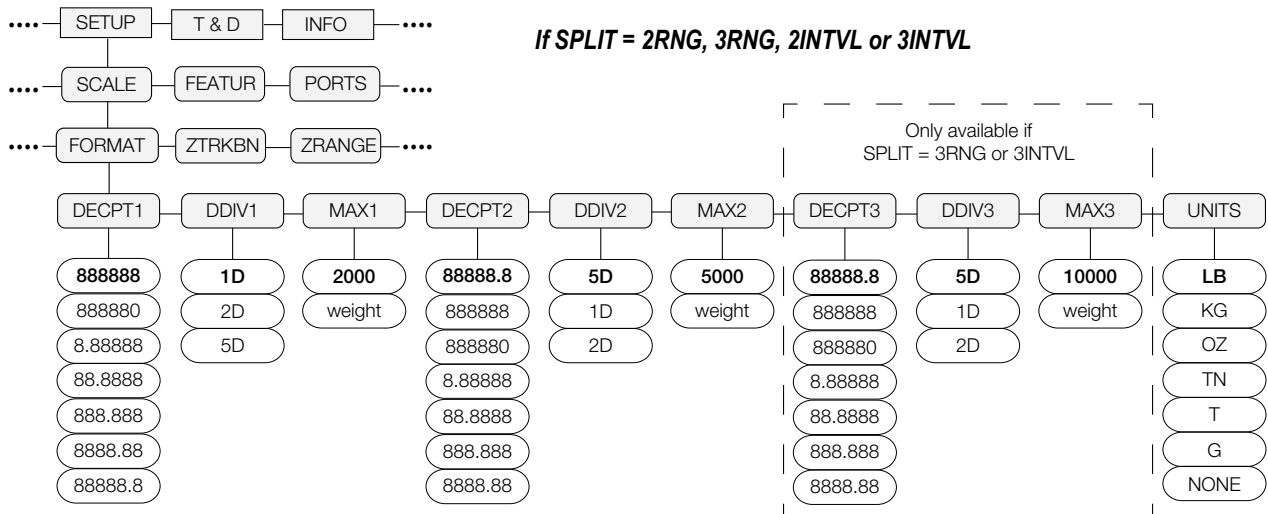

Figure 3-7. Format Menu Structure With Split 2RNG, 3RNG 2INTVL or 3INTVL

Parameter	Choices	Description
If SPLIT = OFF		
PRI	DECPNT DSPDIV UNITS	Primary Units – settings determine the scale capacity and specifies the decimal point, display division and units used; the primary units will display the lb annunciator unless secondary units is set to lb, see Figure 1-3 on page 14 for details
SEC	DECPNT DSPDIV UNITS	Secondary Units – settings determine the Secondary, or Alternate, units value, decimal location, and display division size; the secondary units will display the kg annunciator unless primary units is set to kg, see Figure 1-3 on page 14 for details
If SPLIT = OFF submenu		
DECPNT	888888 888880 8.88888 88.8888 888.888 8888.88 88888.8	Decimal Point Location – specifies the location of the decimal point or dummy zeros in the unit display; Defaults: Primary – 888888; Secondary – 88888.8
DSPDIV	1D 2D 5D	Display Divisions – when combined with the decimal point location, specifies the minimum division size for the displayed weight; scale capacity is determined by display division x graduations; Defaults: Primary – 1D; Secondary – 5D
UNITS	LB KG OZ TN T G NONE	Units – specifies units for displayed and printed weight; LB = pound (lights lb LED) – primary default; KG = kilogram (lights kg LED) – secondary default; OZ = ounces; TN = short ton; T = metric ton; G = gram
If SPLIT = 2RNG, 3RNG, 2INTVL, or 3INTVL		
DECPT1 DECPT2 DECPT3	888888 888880 8.88888 88.8888 888.888 8888.88 88888.8	Decimal Point Location – specifies the location of the decimal point or dummy zeros in the unit display; Defaults: Primary – 888888; Secondary – 88888.8
DDIV1 DDIV2 DDIV3	1D 2D 5D	Display Divisions – when combined with the decimal point location, specifies the minimum division size for the displayed weight; Defaults: DDIV1 – 1D; DDIV2 & DDIV3 – 5D
MAX1 MAX2 MAX3	1–999999	Maximum weight for first range or interval; default 2000; Maximum weight for second range or interval; default 5000; Maximum weight for third range or interval; default 10000 NOTE: Lights annunciators R1, R2 and R3 under the weight display.
UNITS	LB KG OZ TN T G NONE	Units – Specifies units for displayed and printed weight; LB = pound; KG = kilogram; OZ = ounces; TN = short ton; T = metric ton; G = gram

Table 3-5. Format Menu Parameters

3.2.5 Calibration Menu

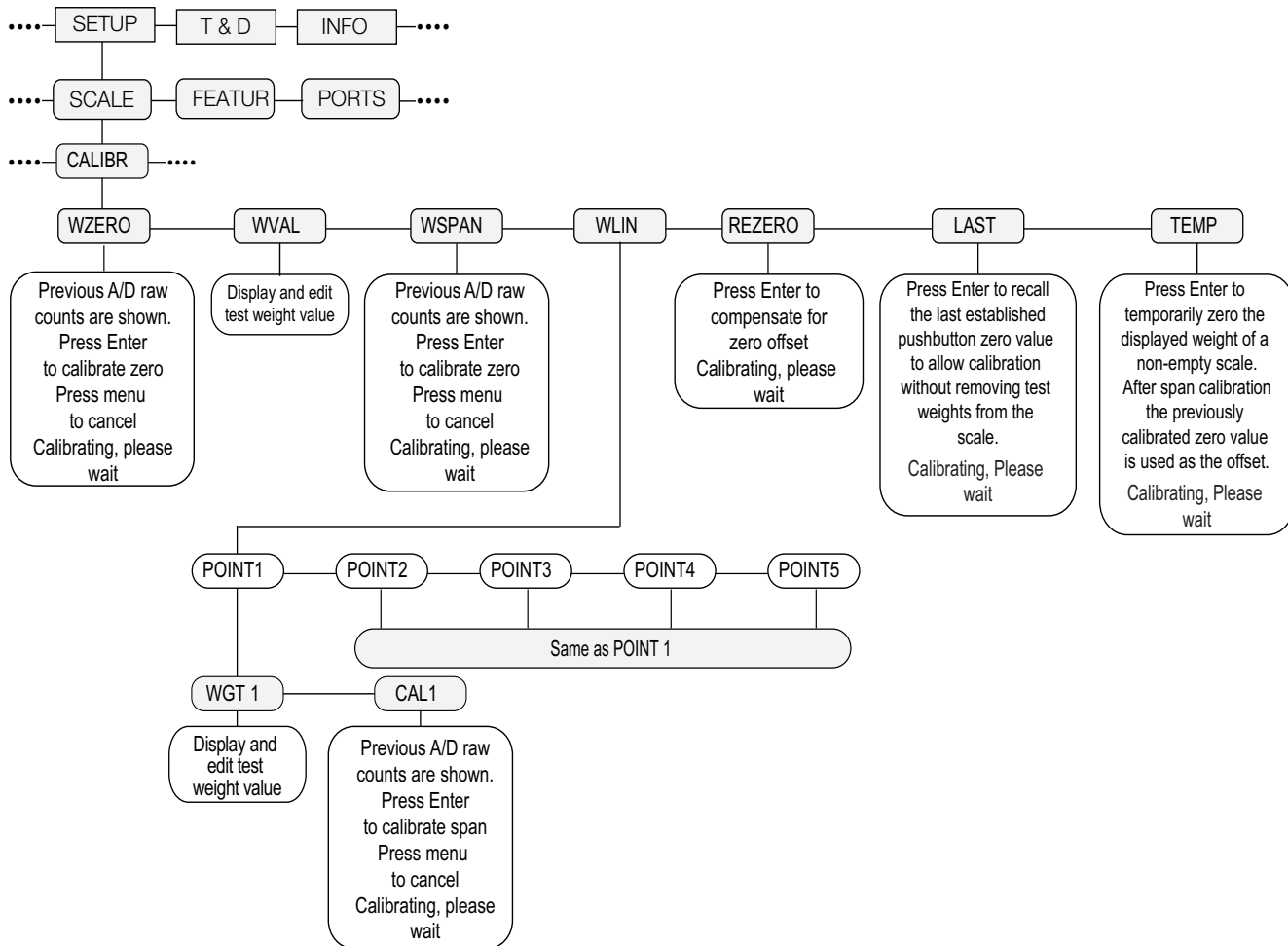

Figure 3-8. Calibration Menu Structure









Parameter	Choices	Description
WZERO	--	Press  to display previous A/D raw counts; press  again to perform a zero calibration
WVAL	--	Press  to display and edit the test weight value
WSPAN	--	Press  to display previous A/D raw counts; press  again to perform a span calibration
WLIN	POINT 1 – POINT 5	Press  to display and edit test weight and calibration values for up to five linearization points; perform linear calibration only after WZERO and WSPAN have been set
REZERO	--	Press  to remove an offset value from the zero and span calibrations; use REZERO only after WZERO and WSPAN have been set, see Section 4.1 on page 70 for more information about using this REZERO
LAST	--	Press  to recall the last established push button zero to allow calibration without removing weight from scale, see Section 4.2 on page 72
TEMP	--	Press  to temporarily zero the displayed weight from a loaded scale, see Section 4.3 on page 72

Table 3-6. Calibration Menu Parameters

3.2.6 Feature Menu

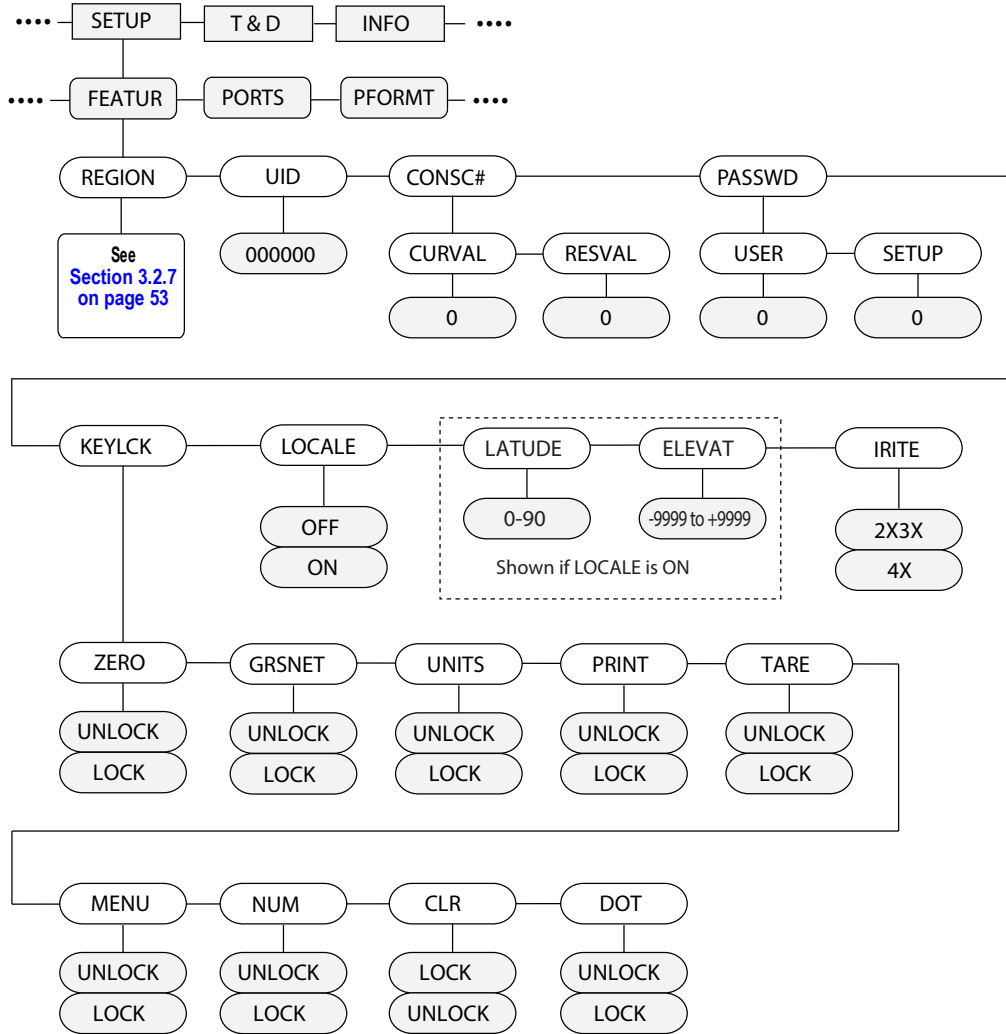

Figure 3-9. Feature Menu Structure

Parameter	Choices	Description
REGION	REGULA REGWRD DECfmt TIME DATE	Selects regional settings, see Level 3 sub menus
UID	000000	Sets the unit ID, a string of up to 6 ASCII characters, which can be set via serial port or keypad; this will be used in place of the <UID> token in a print format; the default value is "1"; the Unit ID is also used as part of the File Name for configuration storage and printing to USB Flash Drives
CONSC#	CURVAL RESVAL	Allows sequential numbering for print operations (CURVAL is the current value and RESVAL is the reset value); the consecutive number value is incremented following each print operation that includes <CN> in the ticket format; when the consecutive number is reset, it is reset to the RESVAL specified in the parameter
PASSWD	USER SETUP	Sets a password to access the Setup menu, or certain sub-menus in the User menu; specify a non-zero value to enable the password; the Setup password protects the entire Setup menu, and when set is required even when attempting entry into the Setup menu using the setup switch; the User password restricts access to the Time/Date, Accumulator, and Setpoints sub-menus in the User menu; passwords can be overridden by loading new firmware, or entering 999999; overriding passwords will clear configuration and calibration settings; to preserve settings (i.e., ID information), use Revolution software to upload the data to a computer, then download it back to the 880 after the password override is performed

Table 3-7. Feature Menu Parameters



Parameter	Choices	Description
KEYLCK	ZERO GRSNET UNITS PRINT TARE MENU NUM CLR DOT	Disables the listed keys; select Lock to disable the key, and Unlock to enable the key
LOCALE	OFF ON	Gravity compensation enable/disable; set this parameter On to enable the LATUDE and ELEVAT
LATUDE	45 0-90	Press  to display and edit the latitude in degrees for gravity adjustment to calibration (LOCALE must be set to On)
ELEVAT	345 -9999-9999	Press  to display and edit the elevation in meters for gravity adjustment to calibration (LOCALE must be set to On)
IRITE	2X3X 4X	Specifies the compatibility level for iRite programs NOTE: The iRite keypress handler changed in Firmware version 4.0. If using an existing iRite program that was written for Version 2X or 3X firmware, use the 2X3X setting. If starting an iRite program from scratch, use the 4X setting. 2X3X - When one of the main front panel keys (units, zero, print, gross/net, tare) is pressed, the associated key handler engages and the associated navigation key handler engages 4X -When one of the main front panel keys is pressed (units, zero, print, gross/net, tare), only the associated key handler engages; The 4X setting is needed when using a USB keyboard and its up/down/left/right arrow and the enter keys

Table 3-7. Feature Menu Parameters (Continued)

3.2.7 Region Menu

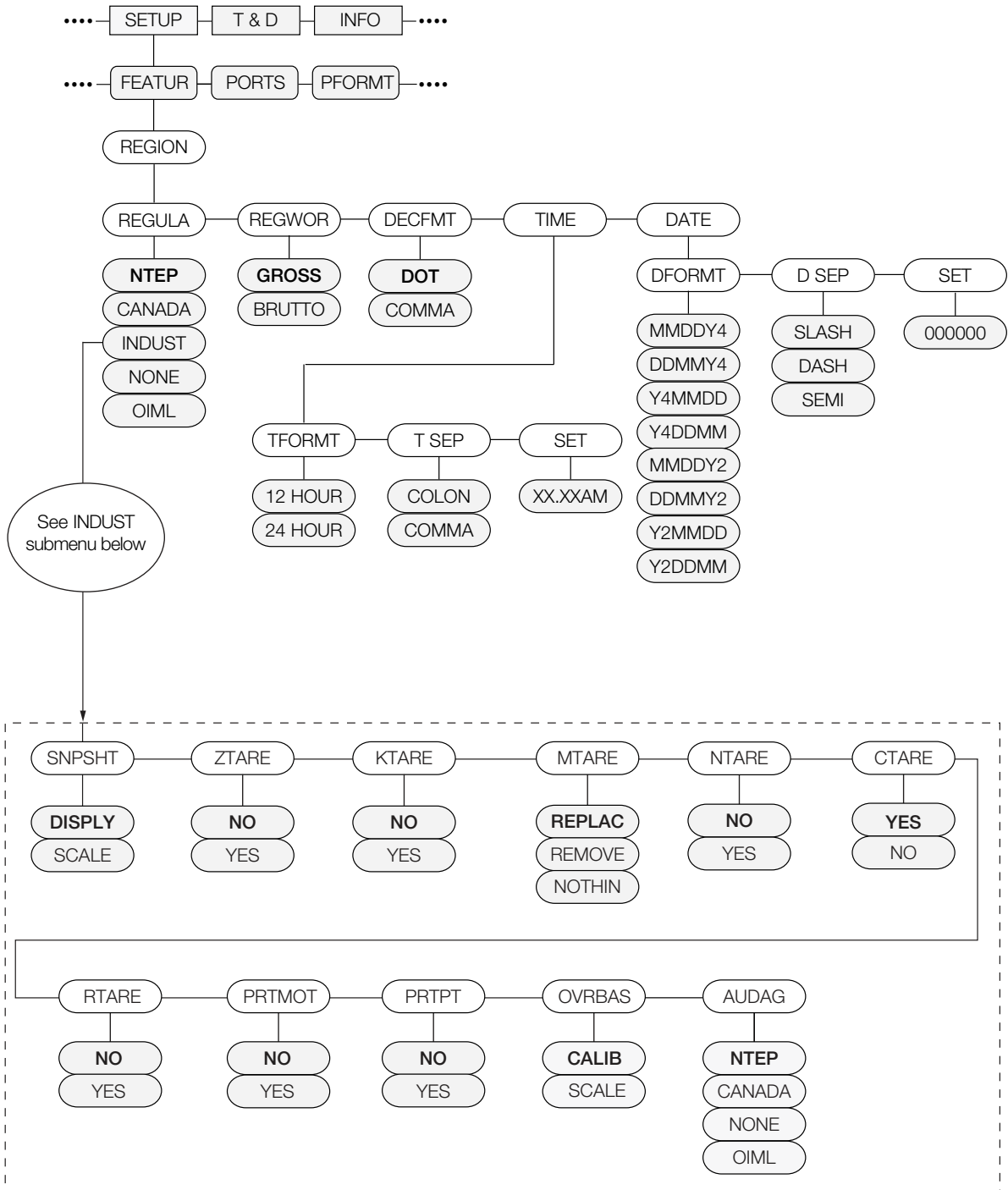

Figure 3-10. Region Menu Structure



Parameter	Choices	Description
REGULA	NTEP CANADA INDUST NONE OIML	Regulatory mode – specifies the regulatory agency having jurisdiction over the scale site; the value specified for REGULA affects the function of the front panel  and Zero keys; OIML, NTEP, and CANADA modes allow a tare to be acquired at any weight greater than zero; NONE allows tares to be acquired at any weight value; OIML, NTEP, and CANADA modes allow a tare to be cleared only if the gross weight is at no load; NONE allows tares to be cleared at any weight value; NTEP and OIML modes allow a new tare to be acquired even if a tare is already present; in CANADA mode, the previous tare must be cleared before a new tare can be acquired; NONE, NTEP and CANADA modes allow the scale to be zeroed in either gross or net mode as long as the current weight is within the specified ZRANGE; in OIML mode, the scale must be in gross mode before it can be zeroed; pressing  in net mode will zero the scale and clear the tare, if weight is within the specified ZRANGE; INDUST provides a set of sub-parameters to allow customization of tare, clear, and print functions in non-legal-for-trade scale installations, see sub-menu below
REGWOR	GROSS BRUTTO	Sets the term displayed when weighing in gross mode; selecting BRUTTO replaces the Gross annunciator with Brutto
DECfmt	DOT COMMA	Specifies whether decimal numbers are displayed using a period (DOT) or a comma
TIME	TFORMT TSEP SET	Allows setting of the current time, and the time format and separator character
DATE	DFORMT D SEP SET	Allows setting of the current date, and date format and date separator character
INDUST sub-menu		
SNPSHT	DISPLY SCALE	Snap Shot uses either the displayed weight or scale weight to determine restrictions; allows a method where Industrial mode will take values from the display
ZTARE	NO YES	Remove tare on Zero
KTARE	NO YES	Always allow keyed tare
MTARE	REPLAC REMOVE NOTHIN	Multiple tare action
NTARE	NO YES	Allow negative or zero tare
CTARE	NO YES	Allow Clear key to clear tare
RTARE	YES NO	Round push button tare value to nearest display division
PRTMOT	NO YES	Allow print while in motion
PRTPT	NO YES	Print PT (preset tare) for keyed tare entries
OVRBAS	CALIB SCALE	Overload Bases uses either the calibrated zero or the scale zero for overload calculation; CALIB = Calibrated Zero; SCALE = Scale Zero
AUDAG	NTEP CANADA NONE OIML	Selects the Audit Agency having jurisdiction over the scale site; OIML, NTEP, and CANADA modes allow a tare to be acquired at any weight greater than zero; NONE allows tares to be acquired at any weight value; A tare can be cleared only if the gross weight is at no load; NONE allows tares to be cleared at any weight value; NTEP and OIML modes allow a new tare to be acquired even if a tare is already present; In OIML mode, printing is not allowed if the scale is more than -20 display divisions; In CANADA mode, the previous tare must be cleared before a new tare can be acquired; NONE, NTEP and CANADA modes allow the scale to be zeroed in either gross or net mode as long as the current weight is within the specified ZRANGE; In OIML mode, the scale must be in gross mode before it can be zeroed; Pressing ZERO in net mode clears the tare; Value specified for this parameter affects the function of the front panel Tare and Zero keys (Section 10.5 on page 109)

Table 3-8. Region Menu Parameters

3.2.8 Ports Menu

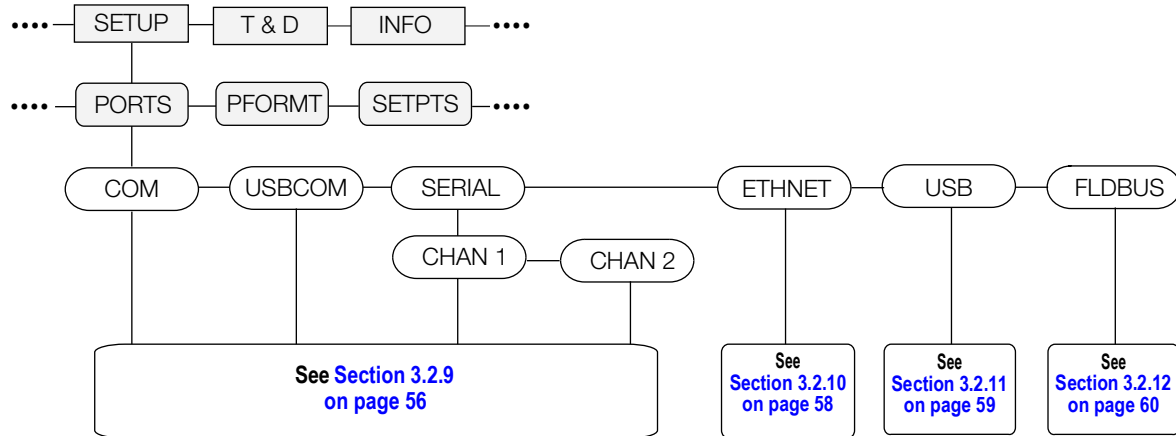

Figure 3-11. Ports Menu Structure

Parameter	Choices	Description
COM	--	RS-232 and RS-485/422 Communications Port – See Figure 3-12 on page 56
USBCOM	--	USB Device Port – See Figure 3-12 on page 56
SERIAL	CHAN 1 CHAN 2	Optional Serial Card Channel 1 - See Figure 3-12 on page 56 Optional Serial Card Channel 2 - See Figure 3-12 on page 56
ETHNET	--	Ethernet TCP/IP Port – See Figure 3-13 on page 58
USB	MEM	USB Host Memory Device functions - See Figure 3-14 on page 59
FLDBUS	--	Field bus option card port when CompactCom board is installed – See Figure 3-15 on page 60

Table 3-9. PORT Menu Parameters

3.2.9 COM, USBCOM, and SERIAL Menus

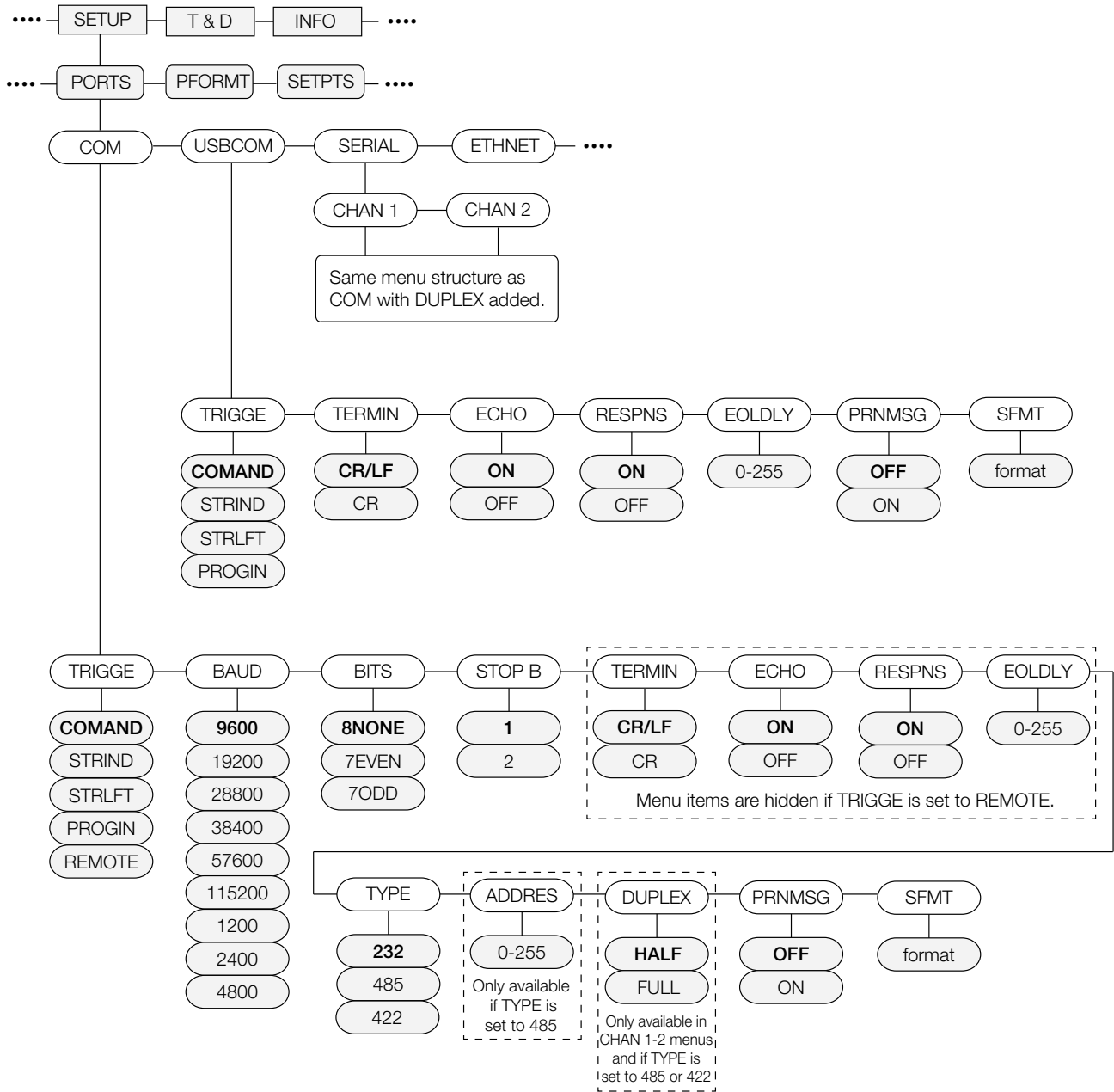

Figure 3-12. COM, USBCOM, and SERIAL Menu Structures

Parameter	Choices	Description
TRIGGE	COMAND	Setting Trigger to command allows operation of EDP commands and can print
	STRLFT	Stream Legal for Trade data – data is updated at the configured display update rate; allows operation of EDP commands and printing
	STRIND	Stream Industrial scale data – data is updated up to the configured sample rate; allows operation of EDP commands and printing
	PROGIN	Programmable input – for use with an iRite user program
	REMOTE	Configures the port to operate as a serial scale input, see Menu Structure if TRIGGE is set to REMOTE below (not available in USBCOM)
When in STRLFT, STRIND and REMOTE, if the COM port is set to TYPE = RS485, the port will not stream data, and cannot be used in a local/remote application, see Section 10.6.3 on page 111		
BAUD	9600 19200 28800 38400 57600 115200 1200 2400 4800	Port baud rate (not available in USBCOM)
BITS	8NONE 7EVEN 7ODD	Port data bits and parity (not available in USBCOM)
STOP B	1 2	Stop Bits – selects the number of stop bits transmitted and the number of stop bits expected to be received by the port (not available in USBCOM)
TERMIN	CR/LF CR	Termination – selects the termination character(s) for data sent from the port
ECHO	ON OFF	Specifies whether characters received by the port are echoed back to the sending unit
RESPNS	ON OFF	Response – specifies whether the port transmits replies to serial commands
EOLDLY	0–255	End of Line Delay – specifies, in 0.1 second intervals, the delay between transmitted lines of data
TYPE	232 422 485	Type – Specifies the protocol for the COM port (not available in USBCOM)
ADDRES	0–255	Address – If TYPE is 485, specifies the RS-485 address (not available in USBCOM)
DUPLEX	FULL HALF	Duplex – Only applies to the RS-485 or RS-422 communications; parameter only available in CHAN 1 and CHAN 2 menus if TYPE is 485 or 422; FULL (default) for 4-wire connection HALF for 2-wire connection
PRNMSG	OFF ON	Print message – displays a message when a print is transmitted on this port
SFMT	<2><P><W7.> <U><M><S> <CR><LF>	Stream format – specifies the stream format used for streaming output of scale data (TRIGGE=STRLFT or STRIND) or specifies the expected input for a serial scale (TRIGGE=REMOTE); See Section 10.7 on page 112

Table 3-10. COM, USBCOM, and SERIAL Menu Parameters

3.2.10 Ethernet Menu

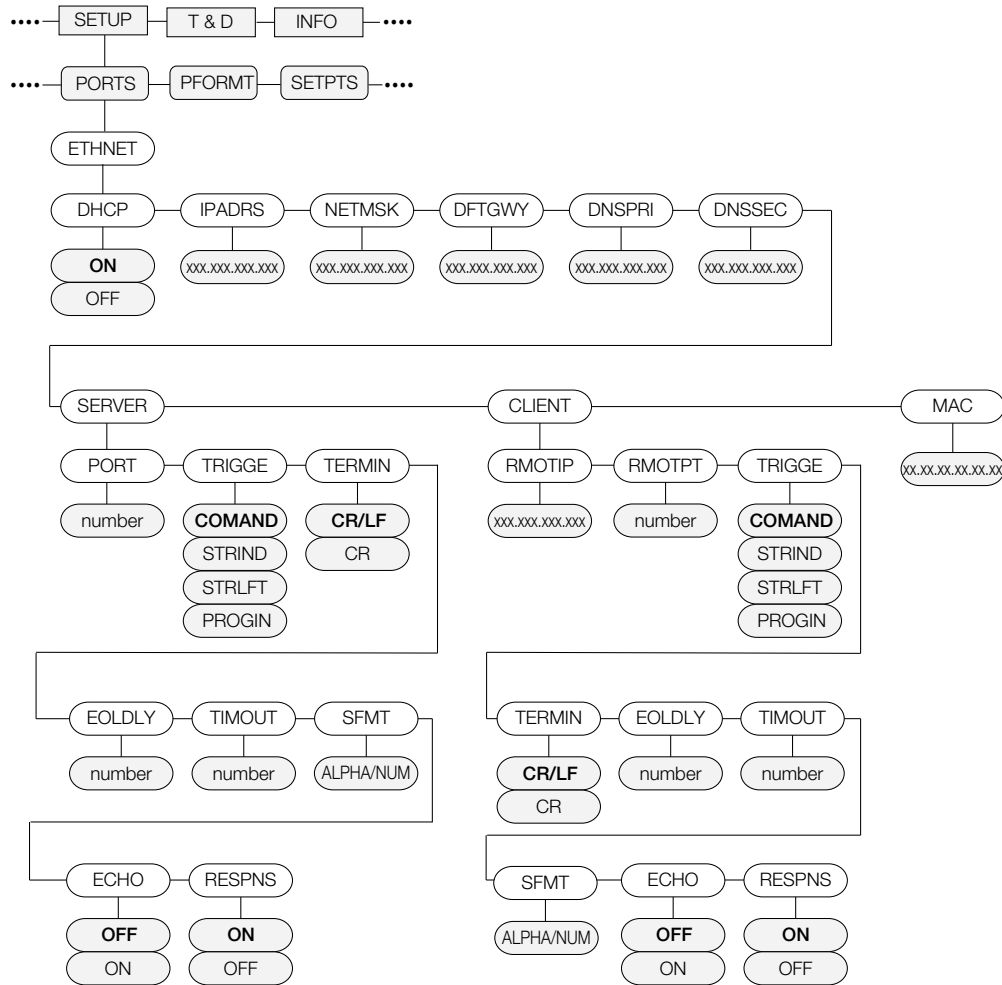

Figure 3-13. Ethernet Menu Structure

Parameter	Choices	Description
DHCP	ON OFF	Enables (ON) or disables (OFF) Dynamic Host Configuration Protocol
IPADRS	000.000.000.000 Valid IP Address	Configures the IP address for this device but not for Fieldbus card
NETMSK	000.000.000.000 Valid Net Mask	Specifies the subnet mask
DFTGWY	000.000.000.000 Valid IP Address	Default Gateway
DNSPRI	000.000.000.000 Valid IP Address	IP address for the primary DNS server
DNSSEC	000.000.000.000 Valid IP Address	IP address for the secondary DNS server
SERVER		See SERVER sub-level menu below
CLIENT		See CLIENT sub-level menu below
MAC	00.00.00.00.00.00	The MAC address for this device, read only
SERVER/CLIENT Sub-level		
RMOTIP	000.000.000.000 Valid IP Address	Remote IP address - IP address of the remote unit the 880 indicator will connect to Client level only

Table 3-11. Ethernet Menu Parameters

Parameter	Choices	Description
RMOTPT	1 1-65535	Remote port - TCP port number on the remote unit that the 880 will connect to Client level only
PORT	10001 1-65535	The TCP port number of the 880 server Server level only
TRIGGE	COMAND STRIND STRLFT	Selects the operation of the port COMAND - allows operation of EDP commands and will print STRLFT - stream Legal-for-Trade scale data - data is transmitted at the configured display update rate. Will also accept EDP commands and printing STRIND - stream industrial scale data - data is transmitted up to the configured A/D sample rate. Will also accept EDP commands and printing
TERMIN	CR/LF CR	Termination. Selects the termination character(s) for data sent from the port
EOLDLY	0 0-255	Port end-of-line delay - specifies, in 0.1 second intervals, the delay between transmitted lines of data
TIMOUT	0 0-65535	Timeout - inactivity disconnect timeout. A connections (either client or server) is closed if there is no activity before the timeout expires. Time is in seconds. A timeout value of 0 disables the inactivity disconnect
SFMT	<2><P><W7.><U> <M><S><CR><LF> >	Stream format - specifies the stream format used for streaming output of scale data (TRIGGE=STRLFT or STRIND). Alphanumeric maximum length is 200 characters
ECHO	OFF ON	Specifies whether characters received by the port are echoed back to the sending unit
RESPNS	ON OFF	Response - specified whether the port transmits replies to serial commands NOTE - If an unexpected device (such as a printer), that may transmit unexpected data (such as a low paper message), is connected to the indicator the response parameter should be set to OFF to prevent a reply from the indicator from confusing the external device.

Table 3-11. Ethernet Menu Parameters (Continued)

3.2.11 USB Host

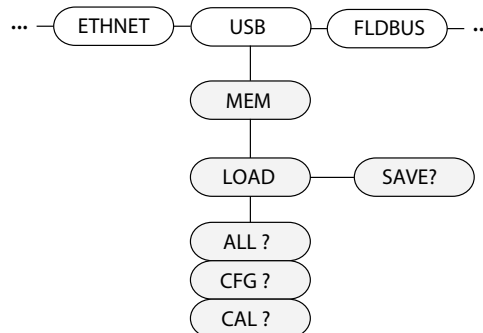

Figure 3-14. USB Host Menu Structure

Parameter	Choices	Description
MEM	SAVE?	Save Configuration to a memory device
--	LOAD	Load Configuration from a memory device; CFG ? — loads only configuration CAL ? — loads only calibration ALL ? — loads all data

Table 3-12. USB HOST Menu Parameters



NOTE: For more information on the use of the USB Host features, see [Section 9.2 on page 105](#).
Keyboard is automatically recognized upon connecting.

3.2.12 Fieldbus Menu

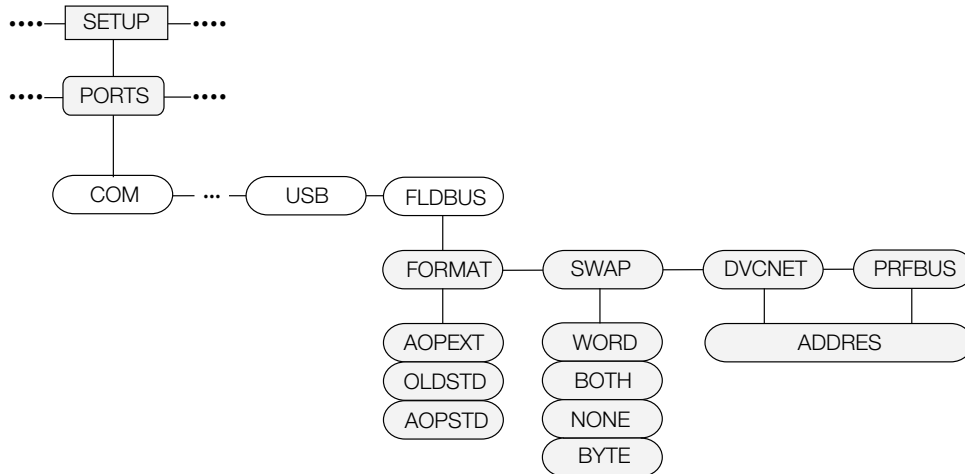

Figure 3-15. Fieldbus Menu Parameters

Parameter	Choices	Description
FORMAT	AOPEXT OLDSTD AOPSTD	8 BYTE input and output is used with Smartcard firmware 2.18 8 BYTE input and output is used with Smartcard firmware 2.02
SWAP	NONE BYTE WORD BOTH	Specifies byte-swapping used for the field bus card; for DeviceNet cards, this parameter defaults to BYTE; for all other cards the default value is none
DVCNET	63 1-64	DeviceNet option address
PRFBUS	126 1-126	Profibus option address

Table 3-13. Fieldbus Menu Parameters

3.2.13 Print Format Menu

See [Section 7.0 on page 93](#) for information about custom print formatting.

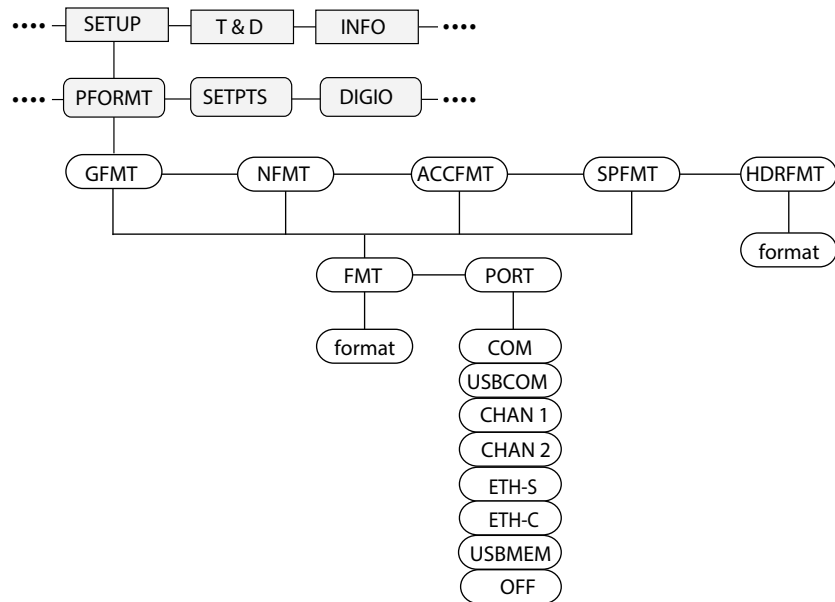

Figure 3-16. Print Format Menu Structure

Parameter	Choices	Description
GFMT	--	Alphanumeric, max length: 1000
	FMT	Weigh mode, no tare in system; GROSS<G><NL2><TD><NL>
	PORT	The communications port the print data will be sent to: COM, USBCOM, CHAN 1, CHAN 2, ETH-S, ETH-C, USBMEM, OFF
NFMT	--	Alphanumeric, max length: 1000
	FMT	Weigh mode, tare in system; GROSS<G><NL>TARE<SP><T><NL>NET<SP2><N><NL2><TD><NL>
	PORT	The communications port the print data will be sent to: COM, USBCOM, CHAN 1, CHAN 2, ETH-S, ETH-C, USBMEM, OFF
ACCFMT	--	Alphanumeric, max length: 1000
	FMT	Accumulator enabled and displayed, or setpoint print operation with PSHACC=ON; ACCUM<A><NL><DA><TI><NL>
	PORT	The communications port the print data will be sent to: COM, USBCOM, CHAN 1, CHAN 2, ETH-S, ETH-C, USBMEM, OFF
SPFMT	--	Alphanumeric, max length: 1000
	FMT	Setpoint print operation with PSHPRNT=ON; <SCV><SP><SPM><NL>
	PORT	The communications port the print data will be sent to: COM, USBCOM, CHAN 1, CHAN 2, ETH-S, ETH-C, USBMEM, OFF
HDRFMT	--	Must be inserted into other print format. Alphanumeric, maximum length 300; COMPANY NAME<NL>STREET ADDRESS<NL>CITY, ST ZIP<NL2>

Table 3-14. Print Format Menu Parameters



NOTE: For all PORT choices, if the COM port is set to TYPE = RS485, the port will not perform a demand print, See [Section 10.6.3 on page 111](#).

Available Print Ports	
COM	RS-232/422 port - J3, see Section 2.4.6 on page 33
USBCOM	USB Device port - J4, see Section 2.4.8 on page 34
CHAN 1	Serial Card Channel 1 - see Section 2.4.6 on page 33
CHAN 2	Serial Card Channel 2 - see Section 2.4.6 on page 33
ETH-S	Ethernet Server - J6, see Section 9.1 on page 101
ETH-C	Ethernet Server - J6, see Section 9.1 on page 101
USBMEM	Print File on USB Flash Drive, see Section 9.2.2 on page 106

Table 3-15. Available Printer Ports

3.2.14 Setpoints Menu

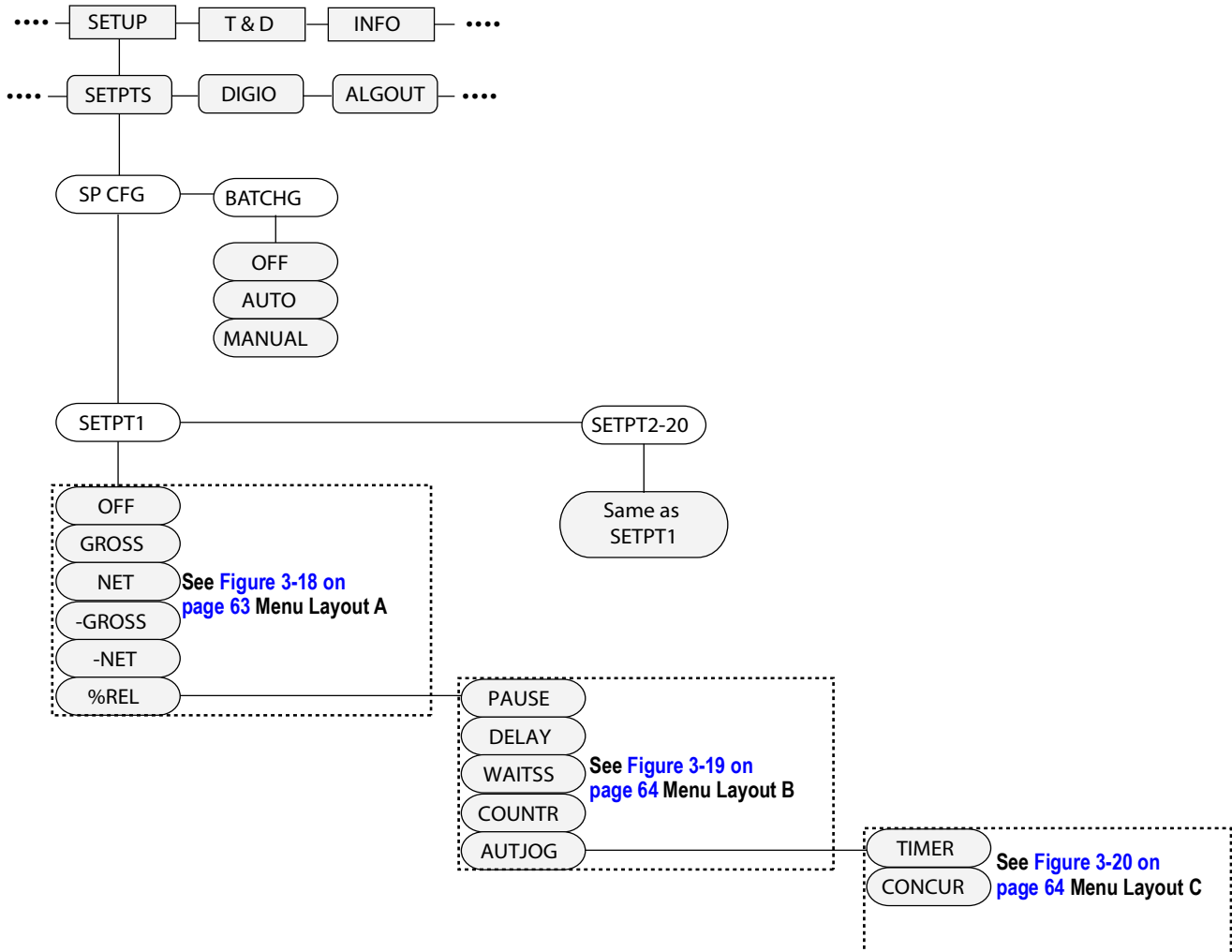

Figure 3-17. Setpoint Menu Structure

3.2.14.1 Gross and Net and Relative Setpoints

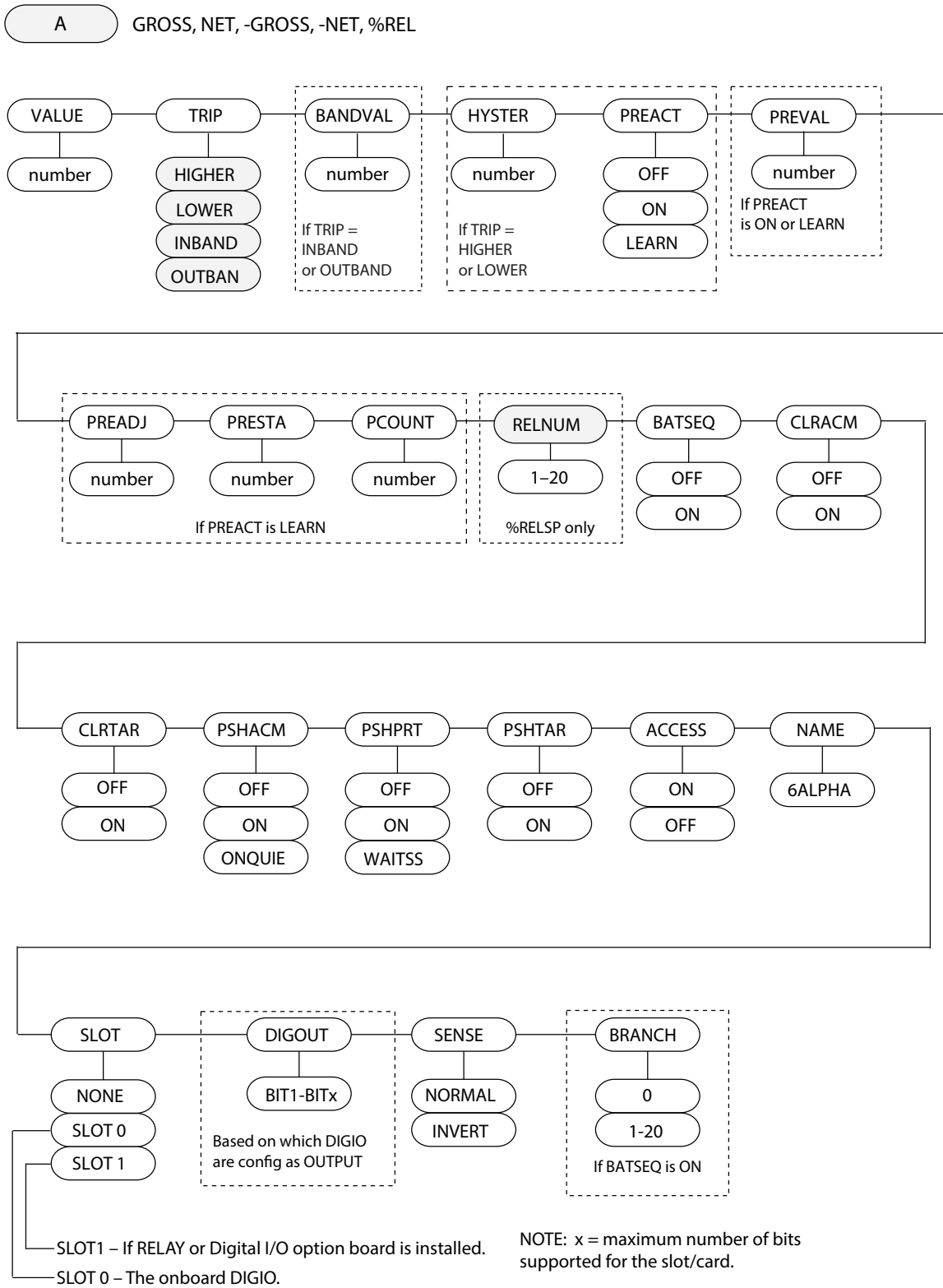

Figure 3-18. Setpoint Menu Structure – Layout A

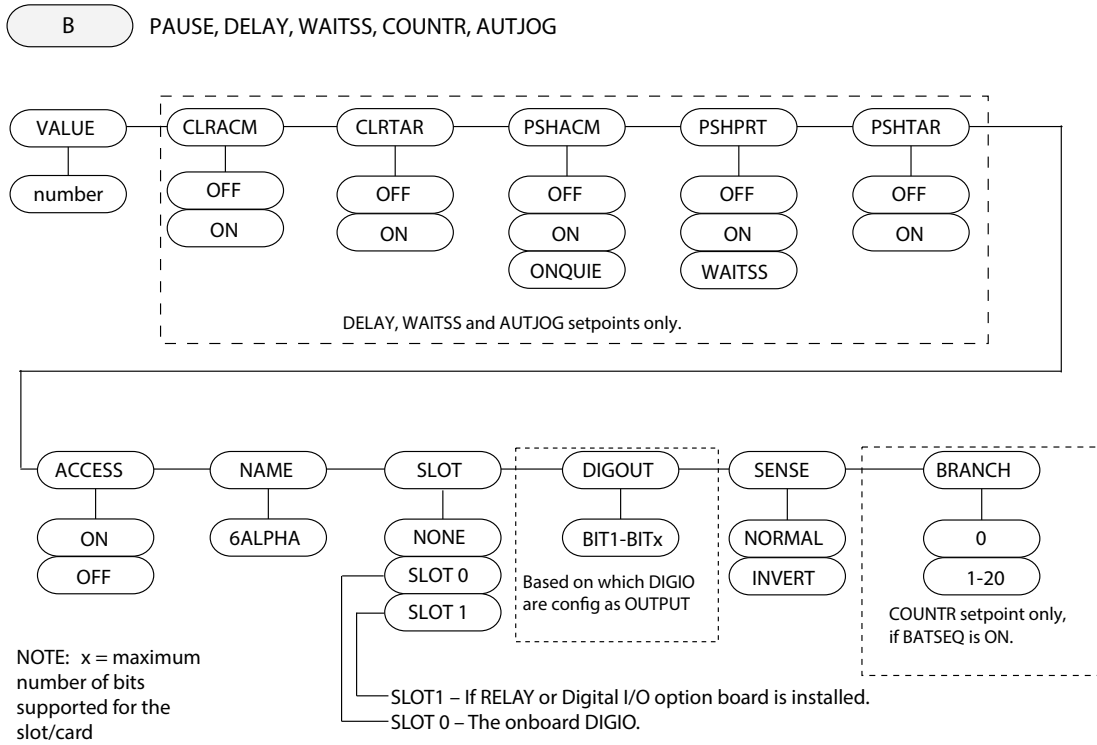

Figure 3-19. Setpoint Menu Structure – Layout B

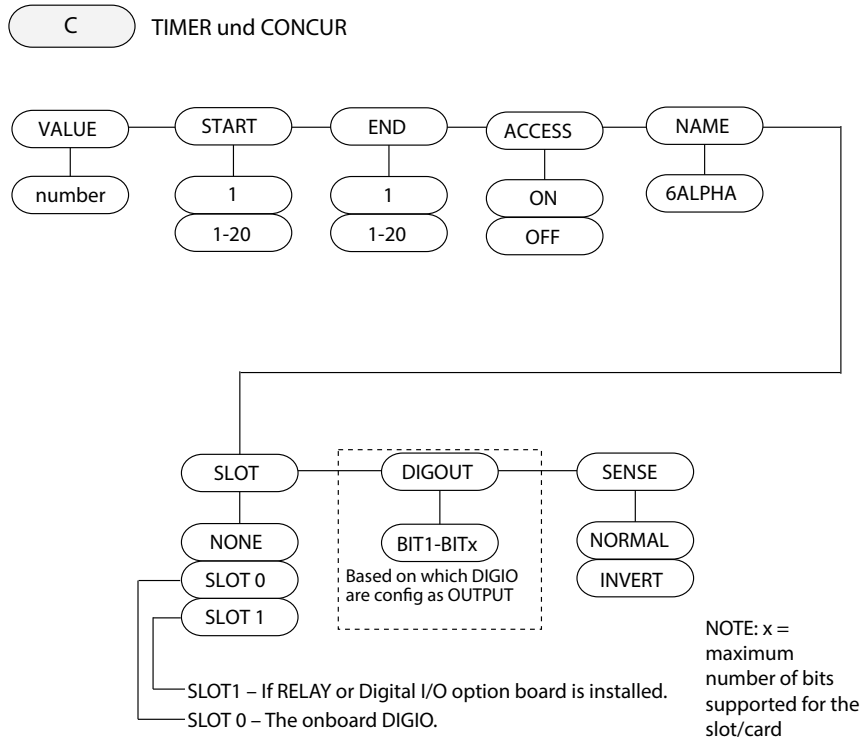

Figure 3-20. Setpoint Menu Structure – Layout C

Parameter	Choices	Description
Level 2 Submenus		
SETPT 1– SETPT 20	OFF GROSS NET –GROSS –NET %REL PAUSE DELAY WAITSS COUNTR AUTJOG TIMER CONCUR	Specifies the setpoint kind; GROSS, NET, –GROSS, –NET, %REL setpoint kinds can be used as either batch or continuous setpoints; PAUSE, DELAY, WAITSS, COUNTR and AUTJOG setpoint kinds can only be used in batch sequences; TIMER and CONCUR setpoint kinds can only be used as continuous setpoints, see Table 8-1 on page 96 for more information about setpoint kinds; The digital output assigned to the Concur setpoint should not be used by another Concur setpoint, this could cause a conflict in setting the output state
BATCHG	OFF AUTO MANUAL	Batching mode – set to AUTO or MANUAL to allow a batch sequence to run; MANUAL requires a BATSTR digital input or BATSTART serial command before the batch sequence can run; AUTO allows batch sequences to repeat continuously after receiving a single batch start signal, see Section 8.2 on page 97
Level 3 Submenus		
VALUE	<i>number</i>	Setpoint value; for weight-based setpoints: specifies the target weight value, 0–999999; for time-based setpoints: specifies, in 0.1-second intervals, a time value in the range 0–65535; for COUNTR setpoints: specifies the number of consecutive batches to be run, 0–65535
TRIP	HIGHER LOWER INBAND OUTBAND	Specifies whether the setpoint is satisfied when the weight is higher or lower than the setpoint value, within a band established around the value, or outside of that band; in a batch sequence with TRIP=HIGHER, the associated digital output is active until the setpoint value is reached or exceeded; with TRIP=LOWER, the output is active until the weight goes below the setpoint value
BNDVAL	0 0–999999	For setpoints with TRIP=INBAND or OUTBAND, specifies a weight equal to half the band width; the band established around the setpoint value is VALUE ±BNDVAL
HYSTER	0 0–999999	Specifies a band around the setpoint value that must be exceeded before the setpoint, once off, can trip on again
PREACT	OFF ON LEARN	Allows the digital output associated with a setpoint to shut off before the setpoint is satisfied to allow for material in suspension; the ON value adjusts the setpoint trip value up or down (depending on the TRIP parameter setting) from the setpoint value using a fixed value specified on the PREVAL parameter; the LEARN value can be used to automatically adjust the preact value after each batch; LEARN compares the actual weight at standstill to the target setpoint value, then adjusts the preact PREVAL by the PREADJ value times the difference after each batch
PREVAL	0 0–999999	Specifies the preact value for setpoints with PRACT set to ON or LEARN; depending on the TRIP setting specified for the setpoint, the setpoint trip value is adjusted up or down by the PREVAL value
PREADJ	50.0 0.0–100.0	Preact adjustment factor; for setpoints with PRACT set to LEARN, specifies a decimal representation of percentage of error correction applied (50 = 50%, 100 = 100%) each time a PRACT is adjusted
PRESTAB	0 0–65535	Preact stabilization time-out; for setpoints with PRACT set to LEARN, specifies the time, in 0.1-second intervals, to wait for standstill before adjusting the PRACT value
PCOUNT	1 1–65535	Preact learn interval; for setpoints with PRACT set to LEARN, specifies the number of batches after which preact value is recalculated; default value is 1; recalculates preact value after every batch cycle
RELNUM	1 1–20	For % REL setpoints, specifies the number of relative setpoints; target weight for this setpoint is percentage (specified on VALUE parameter of the %REL setpoint) of target value of relative setpoint
BATSEQ	OFF ON	Specifies whether the setpoint is used as a batch (ON) or continuous (OFF) setpoint
CLRACM	OFF ON	Specify ON to clear the accumulator when the setpoint is satisfied
CLRTAR	OFF ON	Specify ON to clear the tare when the setpoint is satisfied

Table 3-16. Setpoint Menu Parameters

Parameter	Choices	Description
PSHACM	OFF ON ONQUIE	Specify ON to update the accumulator and perform a print operation when the setpoint is satisfied (uses the accumulator print format); specify ONQUIE to update the accumulator without printing
PSHPRT	OFF ON WAITS	Specify ON to perform a print operation when the setpoint is satisfied; specify WAITSS to wait for standstill after setpoint is satisfied before printing; uses the setpoint print format; for AUTJOG setpoints, it will print only once the previous setpoint is satisfied; instead of printing setpoint print format, it will print GROSS or NET print format (depends on the type of previous setpoint)
PSHTAR	OFF ON	Specify ON to perform an acquire tare operation when the setpoint is satisfied; PSHTAR acquires the tare regardless of the value specified for the REGULA parameter in the FEATUR menu, and regardless of the stability
ACCESS	ON OFF	Specifies the access allowed to setpoint parameters shown in the user menu; ON: values can be displayed and changed; OFF: Values can be displayed but not changed
NAME	6ALPHA	A six character alphanumeric name for the setpoint
SLOT	NONE SLOT 0 SLOT 1	Lists all available digital I/O slots; SLOT 0 – onboard DIO; SLOT 1 – option card (if installed); a slot will only appear if one or more of its individual bits are configured as an output
DIGOUT	BIT 1-BITx	Lists all digital output bits available for the specified SLOT; this parameter is used to specify the digital output bit associated with this setpoint; use the DIGITAL I/O menu Section 3.2.16 on page 67 to assign OUTPUT as the function for the bit associated with this setpoint; for continuous setpoints, the digital output becomes active (low) when the condition is met; for batch setpoints, the digital output is active until the setpoint condition is met
SENSE	NORMAL INVERT	Specifies whether the state of the digital output associated with this setpoint is inverted when the setpoint is satisfied
BRANCH	0 0–20	Specifies the setpoint number to which the batch sequence is to branch if the current setpoint is not satisfied upon initial evaluation; the special value zero indicates that no branch is taken
START	1 1–20	Specifies the starting setpoint number; do not specify the number of the TIMER or CONCUR setpoint itself; the TIMER or CONCUR setpoint begins when the starting setpoint begins
END	1 1–20	Specifies the ending setpoint number; do not specify the number of the TIMER or CONCUR setpoint itself; the TIMER or CONCUR setpoint stops when the ending setpoint begins

Table 3-16. Setpoint Menu Parameters (Continued)



NOTE: If two or more of the CLRxxx and PSHxxx parameters are set on, the actions specified by those parameters are performed in the following order when the setpoint is satisfied: 1) clear accumulator; 2) clear tare; 3) accumulate; 4) print; 5) acquire tare.

3.2.15 Version Menu

The VERS menu is used to check firmware version installed in the indicator and to set the indicator configuration to factory defaults.

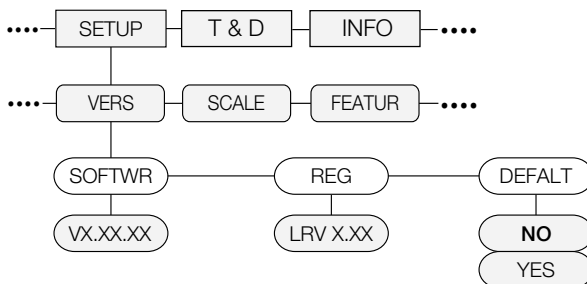

Figure 3-21. Version Menu Structure

Parameter	Choices	Description
SOFTWR	VX.XX.XX	Displays firmware version number
REG	LVR X.XX	Displays the Legally Relevant firmware version number
DEFAULT	NO YES	Performs a reset of all the indicator parameters to factory default settings

Table 3-17. Version Menu Parameters

3.2.16 Digital I/O Menu

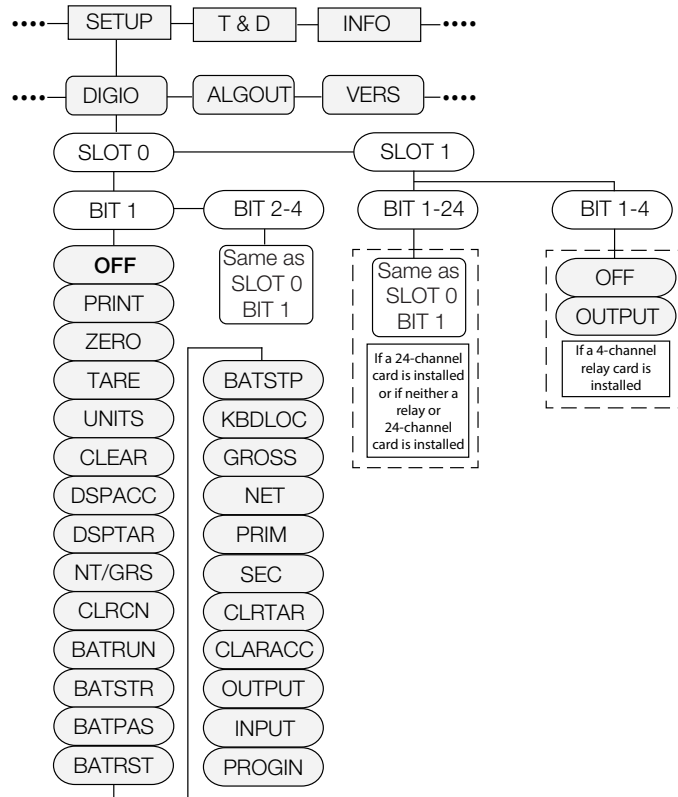

Figure 3-22. Digital I/O Menu

Parameter	Choices	Description
Level 2 Submenus		
SLOT 0	BIT 1 – BIT 4	Select the bit to set the function
Slot 0 Submenu		
BIT 1 BIT 2 BIT 3 BIT 4	OFF PRINT ZERO TARE UNITS CLEAR DSPACC DSPTAR NT/GRS CLRCN BATRUN BATSTR BATPAS BATRST KBDLOC GROSS NET PRIM SEC CLRTAR CLRACC OUTPUT INPUT PROGIN	Specifies the function activated by Bits 1–4; PRINT, ZERO, TARE, UNITS, NT/GRS provide the same functions as the five front panel keys; DSPACC displays the current accumulator value; DSPTAR displays the tare; CLRCN resets the consecutive number to the value specified on the RESVAL parameter (FEATUR menu); BATRUN allows a batch routine to be started and run; with BATRUN active (low), the BATSTR input starts the batch; if BATRUN is inactive (high), BATSTR resets the batch; BATSTR starts or resets a batch routine, depending on the state of the BATRUN input; BATPAS pauses a batch routine while held active (low); BATRST resets a batch to first batch setpoint; BATSTP stops a batch at the current step; KBDLOC locks the keyboard; GROSS, NET, PRIM and SEC select gross or net weight display, and primary or secondary units display modes; CLRTAR clears the current tare; CLRACC clears the accumulator; OUTPUT defines a bit as an output to be used by the setpoint or iRite program; INPUT assigns the bit as a digital input that can be read with the GetDigin iRite API; PROGIN assigns the bit as a digital input used to generate an iRite program event
SLOT 1 - Relay Card	BIT 1 - BIT 4	Select the bit to set the function - only the settings of OFF or OUTPUT are available
SLOT 1 - Digital I/O Card	BIT 1 - BIT 24	Select the bit to set the function - Settings are the same as Slot 0, Bit 1

Table 3-18. Digital I/O Menu Parameters

3.2.17 Analog Output Menu

The ALGOUT menu is used only if the analog output option is installed. If the analog output option is installed, configure all other indicator functions and calibrate the indicator before configuring the analog output, see [Section 10.11 on page 119](#) for analog output calibration procedures.

 **NOTE:** Minimum calibration occurs at 0.5V and 1mA for a 0-10 V and 0-20 mA output respectively.

For analog output board (PN 131601), ensure SW2 switch is in the ON position if installed onto the blue CPU board (PN 175109) or in the OFF position if installed onto the green CPU board (PN 131597). The SW2 switch is located on the backside of the analog output card. This information does not apply for analog output board (PN 164704).

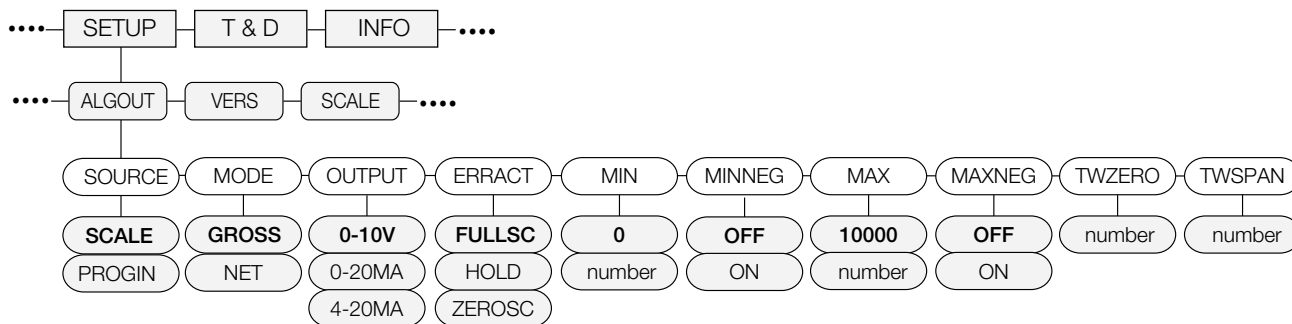

Figure 3-23. Analog Output Menu

Parameter	Choices	Description
Level 2 Submenus		
SOURCE	SCALE PROGIN	Specifies the source of the analog output control; SCALE: indicates that the analog output will follow the configured Mode based on scale data; PROGIN: indicates that the analog output is under iRite program control
MODE	GROSS NET	Defines if the output follows the Gross or Net weight
OUTPUT	0-10V 0-20MA 4-20MA	Selects whether the analog output supplies voltage (0-10 V), current (0-20 mA), or current (4-20 mA)
ERRACT	FULLSC HOLD ZEROSC	Error action. Specifies how the analog output responds to system error conditions; possible values are: FULLSC: set to full value (10 V or 20 mA, depending on output setting); HOLD: hold current value; ZEROSC: set to zero value (0 V, 0 mA or 4 mA, depending on output setting)
MIN	0.000000 number	Specifies the minimum weight value tracked by the analog output; specify a value in the range 0-999999
MIN NEG	OFF ON	Set to ON if the MIN value is negative
MAX	10000.00 number	Specifies the maximum weight value tracked by the analog output; specify a value in the range 0-999999
MAX NEG	OFF ON	Set to ON if the MAX value is negative
TWZERO	000000 number	Calibrate zero; adjust the analog output zero calibration, see Section 10.11 on page 119 ; edit the value to match reading on multimeter to perform calibration
TWSPAN	000000 number	Calibrate span; adjust the analog output span calibration, see Section 10.11 on page 119 ; edit the value to match reading on multimeter to perform calibration

Table 3-19. Analog Output Menu Parameters

4.0 Calibration

The 880 can be calibrated using the front panel, EDP commands, or Revolution.

Calibration consists of the following steps:

- Zero calibration
- Entering the test weight value
- Span calibration
- Optional five-point linearization
- Optional rezero calibration for test weights using hooks or chains
- Optional last zero calibration
- Optional temporary zero calibration



NOTE: The 880 requires the WZERO and WSPAN points to be calibrated. The linearity points are optional; they must fall between zero and span, but must not duplicate zero or span. During calibration,  acts as a data entry confirmation key. It also acts as an execute key, and accepts the value if calibration was successful.

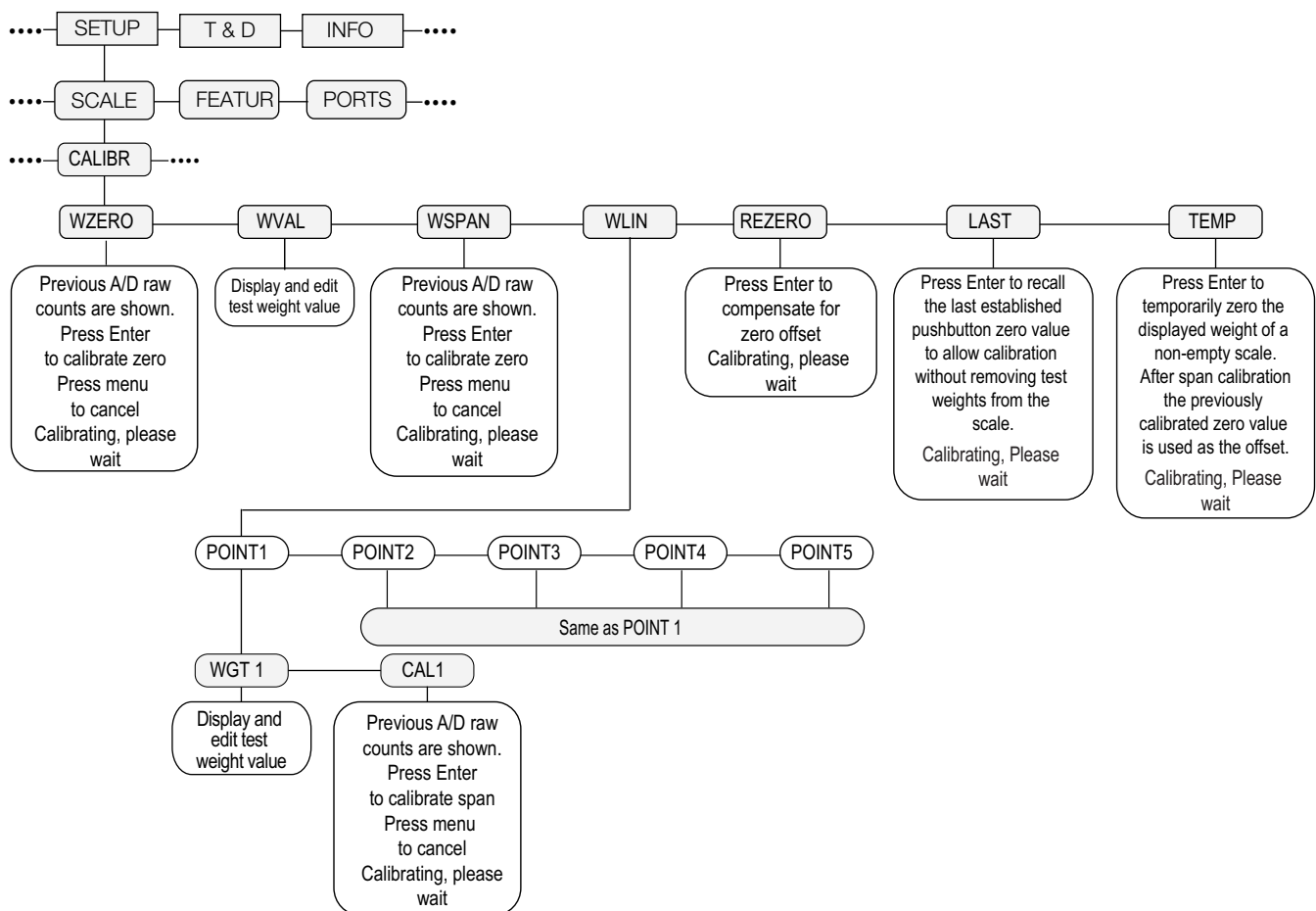









Figure 4-1. Calibration (CALIBR) Menu







4.1 Front Panel Calibration

1. Put the indicator in configuration mode using the setup switch on the back of the unit, see [Figure 3-1 on page 44](#), (or use  if audit trail is enabled), and navigate to CALIBR, see [Figure 4-1 on page 69](#).
2. Press  or ∇ to go to the **WZERO** parameter.
3. Press  or ∇ to view the previously captured A/D count value for zero.
4. Remove all weight from the scale platform. If the test weights require hooks or chains, place the hooks or chains on the scale for zero calibration.
5. Press  to Calibrate WZERO.

 **NOTE:** If calibration of zero is not required, press  to exit.

6. The indicator displays **Calibrating, Please Wait** while calibration is in progress. When complete, **WVAL** is displayed.

 **NOTE:** To view zero A/D count, repeat [Step 3](#). Instead of pressing Enter while viewing value, press Menu to exit.

7. With **WVAL** displayed, press  to display the stored calibration weight value.
8. Edit value using the keypad on the 880 Plus, see [Section 1.7.2 on page 15](#) or the following method for the panel mount.
 - Press \triangleleft or \triangleright to select the digit
 - Press \triangle or ∇ to increment or decrement the value
 - press  when the value is correct
 - Press \triangleleft or \triangleright to move the decimal point position
9. Press  to store the **WVAL** value and advance to **WSPAN**.
10. With **WSPAN** displayed, press  or ∇ to view the previously captured A/D count value for span.
11. Place test weights on the scale equal to **WVAL**.
12. Press  to calibrate **WSPAN**.
13. After  is pressed, the indicator displays **Calibrating, Please Wait**. When complete **WLIN** is displayed.

 **NOTE:** To view span A/D count, repeat [Step 9](#). Instead of pressing Enter while viewing value, press Menu to exit.

14. When calibration is complete press  to return to the weigh mode.





4.1.1 Five-point linearization

Five-point linearization (using the WLIN parameter) provides increased scale accuracy by calibrating the indicator at up to five additional points between the zero and span calibrations.

Linearization is optional: if choosing not to perform linearization, skip the WLIN parameter; if linearization values have previously been entered, these values are reset to zero during calibration of WZERO. To perform linearization, follow the procedure below.





NOTE: The linearity points must be less than the WSPAN point.

1. With **WLIN** displayed, press  to go to the first linearization point (**POINT1**).
2. Press ∇ again, **WGT1** is displayed.
3. Press ∇ to display the value.
4. Edit the value using the keypad on the 880 Plus. See the following method for the panel mount:
 - Press \triangleleft or \triangleright to select the digit
 - Press \triangleup or \triangledown to increment or decrement the value
 - Press  when the value is correct (the decimal point will be set in the following step)
 - Press \triangleleft or \triangleright to move the decimal point position
 - Press  when the value is correct; the indicator will display **CAL1**
5. Place test weights on the scale and press . The indicator will display the previously captured A/D counts for the linearization point.
6. Press  again to calibrate. The indicator displays **Calibrating, Please Wait** while calibration is in progress. When complete, **WGT1** is displayed.
7. Press \triangleup to **POINT1**, then press \triangleright to **POINT2**.
8. Repeat for up to five linearization points. To exit the linearization parameters, press \triangleup to return to **WLIN**.

4.1.2 Rezero

The rezero function is used to remove a calibration offset when an apparatus is used to hang test weights. If no other apparatus was used to hang the test weights during calibration, remove the test weights and press \triangleup to return to the CALIBR menu.

1. With **Rezero** displayed, press  or ∇ to access the rezero function.
2. If an apparatus is used during calibration, remove it and the test weights from the scale. The indicator will display the AD count from the previous zero (**WZERO**) calibration.
3. With all weight removed, press  to rezero the scale. This function acquires a new ZERO calibration value. The indicator displays **Calibrating, Please Wait** while the zero and span calibrations are adjusted. When complete, **Last** is displayed.



NOTE: For more information on **LAST** or **TEMP**, see [Section 4.2 on page 72](#) or [Section 4.3 on page 72](#).

4. Press  to return to weigh mode.

4.2 LAST – Calibrating Zero Without Removing Test Weights

Last zero (typically platform scales) replaces the original captured zero with the last push button zero prior to a calibration.



NOTE: To use this feature a pushbutton zero must have been taken while the scale was empty while in the weigh mode.

Perform a normal calibration, except instead of using WZERO to capture the zero point of an empty scale, select Last to use the last pushbutton zero. The test weight does not need to be removed from the scale.

4.3 TEMP – Establishing a Temporary Zero for Calibrating a Loaded Scale

Temporary zero (typically tank scales) is only a reference for a span calibration, and allows the original zero to be retained after a span adjustment has been done.



NOTE: This procedure assumes the previously calibrated zero point is still accurate.

Perform a normal calibration, except instead of using WZERO to capture the zero point of an empty scale, select Temp. After calibrating the temporary zero, enter the WVAL of the test weights added to the scale (just the test weights, not the product loaded on the scale). Then perform the span calibration.

4.4 Adjusting Final Calibration (Trimming)

Calibration may be affected by environmental factors including wind, vibration, and angular loading. For example, if the scale is calibrated with 1000 lb, a strain test may determine that at 2000 lb the calibration is 3 lb high. In this case, final calibration can be adjusted by changing the WVAL to 998.5 lb. This adjustment provides a linear correction of 1.5 lb per 1000 lb.

4.5 Gravity Compensation

This feature is used to compensate for the variance in gravitational pull from one location to another. To calibrate with gravity compensation, the LOCALE parameter under the **FEATUR** menu must be set to ON, see [Section 3.2.6 on page 51](#), and the LATUDE (latitude) and ELEVAT (elevation in meters, relative to sea level) parameters set before calibrating the indicator.

If the indicator is later installed at a different location, gravity compensation can be applied to a pre-calibrated indicator by adjusting the LATUDE and ELEVAT parameters.

4.6 EDP Command Calibration

To calibrate the indicator using EDP commands, the indicator COM, USBCOM or Ethernet port must be connected to a terminal or personal computer, see [Section 2.6 on page 35](#) for cable connections.



NOTE: The indicator will respond with OK if the value of the parameter was valid, or the command executed properly. If the indicator responds with ??, then either the value for the parameter was invalid, or the command could not be executed

Once the indicator is connected to the sending device, do the following:

1. Place the indicator in configuration mode and remove all weight from the scale platform. If the test weights require hooks or chains, place the hooks or chains on the scale for zero calibration.
2. Send the SC.WZERO#1 command to calibrate zero. The indicator displays **Calibrating, Please Wait** while calibration is in progress.
3. Place test weights on the scale and use the SC.WVAL#1 command to enter the test weight value in the following format:

```
SC.WVAL#1=nnnnnn<CR>
```

4. Send the SC.WSPAN#1 command to calibrate span. The indicator displays **Calibrating, Please Wait** while calibration is in progress.
5. Up to five linearization points can be calibrated between the zero and span calibration values. Use the following commands to set and calibrate a single linearization point:

```
SC.WLIN.V1#1=nnnnn<CR>
```

```
SC.WLIN.C1#1<CR>
```

The SC.WLIN.V1#1 command sets the test weight value (nnnnn) for linearization point 1. The SC.WLIN.C1#1 command calibrates the point. Repeat using the SC.WLIN.Vn#1 and SC.WLIN.Cn#1 (where 'n' is the linearity point number) commands as required for additional linearization points.

6. To remove an offset value, clear all weight from the scale, including hooks or chains used to hang test weights, then send the SC.REZERO#1 command. The indicator displays **Calibrating, Please Wait** while the zero and span calibrations are adjusted.
7. Send the KMENU or KEXIT EDP command to return to weigh mode.

4.7 Revolution Calibration

To calibrate the indicator using Revolution, the indicator serial port must be connected to a computer running the Revolution configuration utility. With the 880 connected to the PC:

1. Place the indicator in configuration mode (display reads **CONFIG**).
2. From Revolution, select **New** from the File menu.
3. The *Select Indicator* dialog box will appear. Select *880* and click **OK**.
4. From the Communications menu, select **Connect**.
5. From the left pane, select **Scale** selection and select the *Scale* button.
6. From the Tools menu, select **Calibration Wizard**.
7. Select **Next** to begin the Calibration Wizard.
8. Select Standard Calibration (zero and span) or Standard with Multi-Point Linearization and then click **Next** to continue.
9. In the text box, enter the test weight value to be used for span calibration.
10. Select the check box if using chains or hooks during the calibration, then select **Next**.
11. Remove all weight from the scale and select click the **Calibrate Zero** to begin zero calibration. If the test weights require an apparatus to hang, place it on the scale for zero calibration.
12. When zero calibration is complete, the Calibration Wizard prompts to place test weights on the scale. Place the test weights on the scale, then select **Calibrate Span**.
13. If choosing to perform linear calibration, the Calibration Wizard now displays prompts (1–5). Enter the weight value for Linear Point #1, place test weights on scale and select **Measure**. Repeat for additional linearization points, then select **Next**.
14. If the check box for using chains or hooks is selected, the Calibration Wizard prompts to perform a Re-zero. Remove the apparatus used to hang the weights, and select **Re-Zero** to calibrate the zero offset.
15. The new and old calibration settings are displayed. To accept the new values, select **Finish**. To exit and restore the old values, select **Cancel**.

5.0 Using Revolution

The Revolution utility provides functions used to support database management, iRite program editing, configuration, calibration, customizing and backup of the 880 configuration settings using a computer.

Calibration values, scale configuration, batch routines, and print ticket formatting can be configured, saved and restored to the 880 using Revolution.

The indicator's operating firmware can also be updated using Revolution, see [Section 5.3 on page 76](#) for more details on firmware updating.



NOTE: For system requirements visit the Revolution product page on www.ricelake.com/revolution

5.1 Connecting to the Indicator

Communicating to the 880 can be accomplished using any of the available ports - using a serial connection to the indicator serial (COM) port through J3; using a port on a dual serial option card; using a USB connection and Virtual Comm Port to the indicator's USB Micro Device (USBCOM) port through J4; or using a TCP/IP connection through the Ethernet Port (J6).

After making the physical connection to a computer, select the Options in the Tools menu and configure the communications settings as needed to match the communications method that is being used:

- RS-232 and RS-485 – select the COM port that it will be connected to; settings can be configured manually to match the indicator's current settings, or check the box for “Auto Detect Settings” to have Revolution automatically detect the settings
- USB – select RS-232 as the communication mode, the USB connection appears as a standard COM port to Revolution; note that the comm port for the USB connection will only show in the list of available ports if the indicator is physically connected, and powered on; the settings for baud rate, data and stop bits, and parity do not apply for a USB connection, and do not need to be set to any specific value
- TCP/IP – requires the IP address and TCP Port of the indicator; enter the IP address and port during the communications connection

To open the communication connection, click on CONNECT under the COMMUNICATIONS menu, or the CONNECT button in the Toolbar. Revolution will attempt to establish communications with the indicator. It also can be used to verify the com port being used in the options/settings and in the device manager com/lpt.



NOTE: If Revolution does not detect the indicator, check the:

Physical connections, communications settings in Revolution.

Current settings of the communications port in the indicator.

Indicator communications port TRIGGE parameter is set to COMAND.

If Revolution displays a Version Error, the indicator version of firmware does not match the module used in Revolution. A connection can be forced, but some parameters may not be enabled if they were not originally supported in that module.

5.2 Configuration

The Revolution configuration utility provides the preferred method for configuring the 880 indicator. Revolution runs on a computer to set configuration parameters for the indicator. When Revolution configuration is complete, configuration data is downloaded to the indicator.

5.2.1 New Configuration File

1. Select **New File** on the tool bar (**New** under the file menu can also be used).
2. Select the icon for the indicator with the appropriate firmware version for which the configuration file is to be created.
3. Revolution will create a default configuration file. Edit the settings, upload the indicator's current settings, or download the default setting Revolutions to the indicator.

5.2.2 Open an Existing Configuration File

1. Select **Open File** on the tool bar (**Open** under the file menu can also be used).
2. Navigate to the *.rev file to open then click the **OK** button.
3. Revolution opens the file, selecting the correct indicator module to use with it. Edit the settings, or download the settings to the indicator.

5.2.3 Saving a Configuration File

1. Select **Save File** on the tool bar (**Save** under the file menu can also be used).
 - If the file is new, enter a name when requested
 - If the file already exists, confirm to overwrite the previous file
 - Select **Cancel** to exit the save process without saving
 - Select **Save As** under the file menu if saving to a different file name

5.2.4 Downloading to the Indicator

The **Send Configuration to Device** function in the Revolution Communications menu allows a Revolution configuration file (with or without scale calibration data), database tables, an iRite program file, ticket formats or setpoints to be downloaded to a connected indicator in *Setup* mode.

The **Send Section to Device** function in the Revolution Communications menu allows download of only the currently displayed object, such as a scale configuration.

Because less data is transferred using the **Send Section to Device**, it is typically faster than a full configuration download, but there is an increased possibility that the download may fail due to dependencies on other objects. If the download fails, try performing a complete download using the **Send Configuration to Device** function.

5.2.5 Uploading Configuration to Revolution

The **Get Configuration from Device** function in the Revolution Communications menu allows the existing user settings of a connected indicator to be saved to a file on the computer. Once saved, the configuration file provides a backup that can be quickly restored to the indicator if needed or the file can be edited within Revolution and downloaded back to the indicator.



NOTE: It does not allow for a custom program to be uploaded from the indicator.

5.3 Updating the Indicator CPU or Display Module Firmware

The firmware for the 880 CPU and/or the 880 Display Module can be updated using a computer with a RS232 serial port, and the Revolution indicator configuration software package. Firmware can be updated for just the CPU, just the Display Module, or both.



NOTE: If updating the CPU Firmware, all configuration data, including calibration, will be lost. Use Revolution to upload and save a copy of the current configuration before continuing. After updating, use Revolution to restore the configuration and calibration. Firmware updates can only be done through the RS-232 port. Updates through the USB and Ethernet ports are not supported.

1. Download the new CPU and/or Display Module firmware from www.ricelake.com/880.
 - CPU firmware file – **156650-880CPUFirmwareVx-xx-xx.S19**
 - Display Module firmware file – **156651-880DisplayFirmwareVx-xx-xx.S19**
2. Connect the RS-232 Port (J3) from the CPU board, see [Figure 2-20 on page 32](#) to a computer.
3. Press and hold the **SETUP** switch (located under the Ethernet jack) while applying power to turn on the 880 indicator and put it into **BOOT** mode. The display will be black for several seconds, then display
4. Release the setup switch.
5. Start the Revolution software on the computer.
6. Under file, select **New**.
7. Select the 880 module applicable for the current version of firmware.
8. Under Tools select **Options/Communications/AutoDetect**.
9. Select the **Auto Detect Settings** check box and click **OK**.
10. Under Communications, select **Connect**. Revolution will establish communications with the 880 indicator.



NOTE: If it fails to connect, check the connections.

11. Once connected, select **Update CPU Firmware** or **Update Display Firmware** in the main indicator information screen.
12. Select the file for the Firmware being updated, CPU or Display.

The program will proceed to load the new firmware. This may take several minutes, while in progress do not leave the Revolution window or interrupt the power to the indicator. The progress of the download will be indicated on the Indicator Information screen.

When the download is complete, the program indicates if it was successful or not.



NOTE: If not successful, turn off the power to the indicator, return to step 3, and try the entire procedure again. If problems persist, contact Rice Lake Weighing Systems for technical assistance.

If loading both the CPU and Display Module firmware, after one is complete, turn off the power and start again at [Step 3](#) before loading the other.

5.4 Revolution Help

The menu bar in Revolution contains a Help system for further assistance in using Revolution software.

The help system contains an index of help topics and a search function. The search function allows the user to search with a keyword. When a keyword is typed into the search text box, Help searches its Index and finds the closest related topic in the help system.

6.0 EDP Commands

The 880 can be controlled by a computer or terminal using the EDP commands, which can simulate front panel key press functions, display and change setup parameters, and perform reporting functions.

6.1 The EDP Command Set

The EDP command set can be divided into seven groups: key press commands, reporting commands, the **RESETCONFIGURATION** special function command, parameter setting commands, weigh mode commands, error conditions and batching control commands.

When the indicator processes an EDP command, it responds with the message **OK**. The **OK** response verifies that the command was received and has been executed. If the command is unrecognized or cannot be executed, the indicator responds with **??**.

The following sections list the commands and command syntax used for each of these groups.

6.1.1 Key Press Commands

Key press EDP commands simulate pressing the keys on the front panel of the indicator. These commands can be used in both setup and weighing mode. Several of the commands serve as “pseudo” keys, providing functions that are not represented by a key on the front panel.

For example, to enter a 15-pound tare weight using EDP commands:

1. Type K1 and press **Enter** (or **RETURN**).
2. Type K5 and press **Enter**.
3. Type KTARE and press **Enter**.







Command	Function
KMENU	Press 
KZERO	Press 
KUNITS	Press 
KPRINT	Press 
KTARE	Press 
KGROSSNET	Press 
KGROSS	Go to gross mode (pseudo key)
KNET	Go to net mode (pseudo key)
KDISPACCUM	Display ACCUM (pseudo key)
KDISPTARE	Display tare (pseudo key)
KCLR	Press the Clear key (pseudo key)
KCLR CN	Reset consecutive number (pseudo key)
KCLRTAR	Clear tare from system (pseudo key)
KLEFT	In menu mode, move left in the menu
KRIGHT	In menu mode, move right in the menu
KUP	In menu mode, move up in the menu
KDOWN	In menu mode, move down in the menu
KSAVE	In menu mode, saves the current configuration (pseudo key)

Table 6-1. EDP Key Press Commands

Command	Function
KEXIT	In menu mode, saves the current configuration then exits to weigh mode (pseudo key)
K0–K9	Press number 0 (zero) through 9 (pseudo keys)
KDOT	Press the decimal point (.) (pseudo key)
KENTER	Press the Enter key (pseudo key)
KLOCK	Lock specified front panel key; for example, to lock the Zero key, enter KLOCK=KZERO (pseudo key)
KUNLOCK	Unlock specified front panel key; for example, to unlock the Print key, enter KUNLOCK=KPRINT (pseudo key)
KDATE	Display date (pseudo key)
KTIME	Display time (pseudo key)
KESCAPE	Exits the selected parameter; returns to weigh mode if a parameter is not selected (functions identical to the Menu key in menu mode) (pseudo key)
KPRIM	Change to primary units (pseudo key)
KSEC	Change to secondary units (pseudo key)

Table 6-1. EDP Key Press Commands (Continued)

6.1.2 Reporting Commands

Reporting commands, see [Table 6-2](#) for more information, about sending specific information to the EDP port. These commands can be used in both configuration mode and weigh mode.

Command	Function
AUDITJUMPER	Returns the state of the audit jumper; a response of OK indicates the jumper is in the On position; a response of “??” indicates the jumper is in the Off position
BUILD	Returns the date and time of the software build
DUMPALL	Returns a list of all parameter values
DUMPAUDIT	Returns a list of audit trail information
DUMPCONFIG	Returns a list of all parameter values except for setpoint data
DUMPETH	Returns a list of all Ethernet parameter values
DUMPSP	Returns a list of all setpoint parameter values
HARDWARE	Returns a value that indicates which option card is installed in the option slot; possible values: 000=none, 032=24-channel DIO card, 085=relay card, 101=USB host, 153=analog output card, 170=CompactCom card, 097=dual serial card <i>Example response with a relay card installed: HARDWARE=085</i>
VERSION	Returns the 880 firmware version
DISPLAYBUILD	Returns the date and time of the display module software build; NONE is returned if no display is connected
DISPLAYVERSION	Returns the display module software version; NONE is returned if no display is connected
P	Returns the current displayed weight with units identifier, see Section 10.4 on page 108
OPTVERSION#1	Returns the software version of an installed option card, if supported; returns UNSUPPORTED if not supported; returns NOCARD if no option card is installed
FBTEST	Returns the type of Field Bus module that is connected to the Field Bus Option Card, if installed; returns NOMODULE if no module is installed; returns NOTFOUND if no Field Bus Option Card is installed

Table 6-2. EDP Reporting Commands

6.1.3 The RESETCONFIGURATION Command

The RESETCONFIGURATION command can be used in configuration mode to restore all configuration parameters to their default values.

This command is equivalent to using the DEFAULT function in CONFIG mode.



NOTE: All load cell calibration settings are lost when the RESETCONFIGURATION command is run.

6.1.4 Parameter Setting Commands

Parameter setting commands allow the display or change of the current value for a particular configuration parameter.

Current configuration parameter settings can be displayed in either configuration mode or weigh mode using the following syntax:

`command<CR>`

Most parameter values can be changed in configuration mode only; setpoint parameters listed in [Table 6-16 on page 85](#) can be changed when in normal weighing mode.

Use the following command syntax when changing parameter values:

`command=value<CR>`

Where *value* is the new value you want to assign to the parameter. Use no spaces before or after the equal (=) sign. If an incorrect command has been typed in, the response will be ??.

For example, to set the motion band parameter to 5, type the following:

`SC.MOTBAND#1=5D<CR>`

To see a list of values for parameters with selectable values, in configuration mode only, enter the command and equal sign followed by a question mark:

`command=?<CR>`

6.1.5 Scales Menu

Command	Menu	Description	Choices / Range
SC.ACCUM#1	ACCUM	Accumulator	OFF, ON
SC.DFTHR#1	DFTHR	Digital filter cutout threshold	0-99999
SC.DSPRATE#1	DSPRAT	Display update rate (in 0.1 sec intervals)	1-80
SC.DFSENS#1	DFSENS	Digital filter cutout sensitivity	LIGHT, MEDIUM, HEAVY
SC.GRADS#1	GRADS	Graduations	1-100000
SC.MOTBAND#1	MOTBAN	Motion band (in divisions)	0-100
SC.OVRLOAD#1	OVRLOA	Overload	FS+2%, FS+1D, FS+9D, FS
SC.PWRUPMD#1	PWRUPM	Power up mode	GO, DELAY
SC.RANGE1.MAX#1	MAX1	Maximum weight for first range or interval	0.0-999999.0
SC.RANGE2.MAX#1	MAX2	Maximum weight for second range or interval	0.0-999999.0
SC.RANGE3.MAX#1	MAX3	Maximum weight for third range or interval	0.0-999999.0
SC.SMPRAT#1	SMPRAT	Sample Rate	7.5HZ, 15HZ, 30HZ, 60HZ, 120HZ, 240HZ, 480HZ, 960HZ
SC.SPLIT#1	SPLIT	Specifies full range, multi-range, or multi-interval	OFF, 2RNG, 3RNG, 2INTVL, 3INTVL
SC.SSTIME#1	SSTIME	Stand still time (in 0.1 sec intervals)	1-65535
SC.TAREFN#1	TAREFN	Tare function	BOTH, NOTARE, PBTARE, KEYED
SC.THRESH#1	THRESH	Accumulator zero threshold	0-999999
SC.ZRANGE#1	ZRANGE	Zero range (in % of capacity)	0.0-100.0
SC.ZTRKBN#1	ZTRKBN	Zero track band (in divisions)	0.0-100.0

Table 6-3. Scales EDP Commands

6.1.6 Format Menu

Command	Menu	Description	Choices / Range
If SPLIT = OFF			
SC.PRI.DECPNT#1	DECPNT	Decimal point location (for primary units)	888888, 888880, 8.88888, 88.8888, 888.888, 8888.88, 88888.8
SC.PRI.DSPDIV#1	DSPDIV	Display divisions	1D, 2D, 5D
SC.PRI.UNITS#1	UNITS	Specifies primary units for displayed and printed weight	LB, KG, OZ, TN, T, G, NONE
SC.SEC.DECPNT#1	DECPNT	Decimal point location (for secondary units)	888888, 888880, 8.88888, 88.8888, 888.888, 8888.88, 88888.8
SC.SEC.DSPDIV#1	DSPDIV	Display divisions (for secondary units)	1D, 2D, 5D
SC.SEC.UNITS#1	UNITS	Specifies secondary units for displayed and printed weight	LB, KG, OZ, TN, T, G, NONE
If SPLIT = 2RNG, 3RNG, 2INTVL, 3INTVL			
SC.PRI.DECPNT#1	DECPNT1	Decimal point location for first range or interval	888888, 888880, 8.88888, 88.8888, 888.888, 8888.88, 88888.8
SC.SEC.DECPNT#1	DECPNT2	Decimal point location for second range or interval	888888, 888880, 8.88888, 88.8888, 888.888, 8888.88, 88888.8
SC.TER.DECPNT#1	DECPNT3	Decimal point location for third range or interval; only available in 3RNG or 3INTVL	888888, 888880, 8.88888, 88.8888, 888.888, 8888.88, 88888.8
SC.PRI.DSPDIV#1	DDIV1	Range/Interval 1 division size	1D, 2D, 5D
SC.SEC.DSPDIV#1	DDIV2	Range/Interval 2 division size	1D, 2D, 5D
SC.TER.DSPDIV#1	DDIV3	Range/Interval 3 division size	1D, 2D, 5D

Table 6-4. Format EDP Commands

6.1.7 Calibration Menu

Command	Menu	Description	Choices / Range
SC.WZERO#1	WZERO	Perform zero calibration	--
SC.WSPAN#1	WSPAN	Perform span calibration	--
SC.LC.CD#1	--	Raw count at zero	-2147483646–2147483647
SC.LC.CW#1	--	Raw count at span	-2147483646–2147483647
SC.LC.CZ#1	--	--	-2147483646–2147483647
SC.REZERO#1	REZERO	Perform zero calibration	--
SC.WLIN.C1#1	--	Calibrate linearization point 1	--
SC.WLIN.C2#1	--	Calibrate linearization point 2	--
SC.WLIN.C3#1	--	Calibrate linearization point 3	--
SC.WLIN.C4#1	--	Calibrate linearization point 4	--
SC.WLIN.C5#1	--	Calibrate linearization point 5	--
SC.WLIN.F1#1	CAL 1	Raw count value for linearization point 1	-2147483646–2147483647
SC.WLIN.F2#1	CAL 2	Raw count value for linearization point 2	-2147483646–2147483647
SC.WLIN.F3#1	CAL 3	Raw count value for linearization point 3	-2147483646–2147483647
SC.WLIN.F4#1	CAL 4	Raw count value for linearization point 4	-2147483646–2147483647
SC.WLIN.F5#1	CAL 5	Raw count value for linearization point 5	-2147483646–2147483647
SC.WLIN.V1#1	WGT 1	Test weight value for linearization point 1	0.0–999999.0
SC.WLIN.V2#1	WGT 2	Test weight value for linearization point 2	0.0–999999.0
SC.WLIN.V3#1	WGT 3	Test weight value for linearization point 3	0.0–999999.0
SC.WLIN.V4#1	WGT 4	Test weight value for linearization point 4	0.0–999999.0
SC.WLIN.V5#1	WGT 5	Test weight value for linearization point 5	0.0–999999.0
SC.WVAL#1	WVAL	Test weight value	0.00001–999999.0

Table 6-5. CALIBR EDP Commands



NOTE: The menu items, CAL1 – CAL5 are used to do the calibration. A value cannot be keyed in. The SC.WLIN.Fx#1 EDP commands can be used to view and edit the value but they do not perform the calibration. Use the SC.WLIN.Cx#1 commands to perform the calibration.

6.1.8 Ports COM and SERIAL (Option Card) Menu

Command	Menu	Description	Choices / Range
EDP.BAUD#p	BAUD	Port baud rate	1200, 2400, 4800, 9600, 19200, 28800, 38400, 57600, 115200
EDP.BITS#p	BITS	Port data bits and parity	8NONE, 7EVEN, 7ODD
EDP.ECHO#p	ECHO	Specifies whether characters received by the port are echoed back to the sending unit	OFF, ON
EDP.EOLDLY#p	EOLDLY	Port end-of-line delay in 0.1 sec intervals	Range: 0-255
EDP.TYPE#p	TYPE	Specifies RS-232, RS-485 or RS-422 communication	232, 485, 422
EDP.ADDRESS#p	ADDRES	RS-485 address	Range: 0-255
EDP.PRNMSG#p	PRNMSG	Print message	OFF, ON
EDP.RESPONSE#p	RESPNS	Response	OFF, ON
EDP.SFMT#p	SFMT	Stream format	Alphanumeric, max Length: 200
EDP.STOPBITS#p	STOP B	Stop Bits	1, 2
EDP.TERMIN#p	TERMIN	Termination character(s)	CR/LF, CR
EDP.TRIGGER#p	TRIGGE	Selects the operation of the port	COMAND, STRLFT, STRIND, REMOTE
EDP.DUPLEX#p	DUPLEX	Selects half or full duplex 422/485 (option card ports only)	HALF, FULL

NOTE: #p = 1 for COM, 5 for serial option channel 1 and 6 for serial option channel 2

Table 6-6. PORTS (COM and Serial Option Card) EDP Commands

6.1.9 Ports – Fieldbus Menu

Command	Menu	Description	Choices / Range
FB.DATAFORMAT#1	FORMAT	The data format	OLDSTD, AOPSTD
FB.BYTESWAP#1	SWAP	Specify byte swap for Fieldbus card	NONE, BYTE, WORD, BOTH
FB.DEVICENETADDRESS#1	DVCNET	Address for DeviceNet option	1-64
FB.PROFIBUSADDRESS#1	PRFBUS	Address for Profibus option	1-126

Table 6-7. PORTS – Fieldbus EDP Commands

6.1.10 Ports – Ethernet Menu

Command	Menu	Description	Choices / Range
ETH.DEFAULTGATEWAY	DFTGWY	Default gateway	Valid IP address
ETH.DHCP	DHCP	Dynamic host configuration protocol	OFF, ON
ETH.DNSPRIMARY	DNSPRI	Primary DNS server address	Valid IP address
ETH.DNSSECONDARY	DNSSEC	Secondary DNS server address	Valid IP address
ETH.IPADDRESS	IPADRS	IP address for the indicator	Valid IP address
ETH.MACADDRESS	MAC	MAC address (read only)	N/A – read only
ETH.NETMASK	NETMSK	Subnet mask	Valid IP address
ETH.CLIENT.ECHO	CLIENT ECHO	Specifies whether characters received by the port are echoed back to the sending unit	OFF, ON
ETH.CLIENT.EOLDLY	CLIENT EOLDLY	Port end-of-line delay, in 0.1 second intervals	0–255
ETH.CLIENT.RESPONSE	CLIENT RESPNS	Response – specifies whether the port transmits replies to serial commands; parameter should be set to OFF to prevent a reply from the indicator confusing an external device (such as a printer)	OFF, ON
ETH.CLIENT.REMOTESERVERIP	CLIENT RMOTIP	Remote IP address of the remote machine that the 880 will connect to	Valid IP address
ETH.CLIENT.REMOTESERVERPORT	CLIENT RMOTPT	Remote port number of the remote machine that the 880 will connect to	1–65535
ETH.CLIENT.SFMT	CLIENT SFMT	Stream format – specifies the stream format used for streaming output of scale data (TRIGGE=STRLFT or STRIND)	Alphanumeric, max length: 200
ETH.CLIENT.TERMIN	CLIENT TERMIN	Termination – selects the termination character(s) for data sent from the port	CR/LF, CR
ETH.CLIENT.TIMEOUT	CLIENT TIMOUT	Inactivity disconnect timeout – connection is closed after a specified period (in seconds) of inactivity; setting the value to 0 disables the parameter	0–65535
ETH.CLIENT.TRIGGER	CLIENT TRIGGE	Selects the operation of the client Ethernet port	COMAND, STRLFT, STRIND
ETH.SERVER.ECHO	SERVER ECHO	Specifies whether characters received by the port are echoed back to the sending unit	OFF, ON
ETH.SERVER.EOLDLY	SERVER EOLDLY	Port end-of-line delay, in 0.1 second intervals	0–255
ETH.SERVER.PORT	SERVER PORT	Port that the 880 uses for its server	1–65535
ETH.SERVER.RESPONSE	SERVER RESPNS	Response – specifies whether the port transmits replies to serial commands; parameter should be set to OFF to prevent a reply from the indicator confusing an external device (such as a printer)	OFF, ON
ETH.SERVER.SFMT	SERVER SFMT	Stream format – specifies the stream format used for streaming output of scale data (TRIGGE=STRLFT or STRIND)	Alphanumeric, max length: 200
ETH.SERVER.TERMIN	SERVER TERMIN	Termination – selects the termination character(s) for data sent from the port	CR/LF, CR
ETH.SERVER.TIMEOUT	SERVER TIMOUT	Inactivity disconnect timeout – connection is closed after a specified period (in seconds) of inactivity; setting the value to 0 disables the parameter	0–65535
ETH.SERVER.TRIGGER	SERVER TRIGGE	Selects the operation of the server Ethernet port	COMAND, STRLFT, STRIND

Table 6-8. PORTS – Ethernet EDP Commands

6.1.11 Ports – USBCOM Menu

Command	Menu	Description	Choices / Range
EDP.ECHO#2	ECHO	Specifies whether characters received by the port are echoed back to the sending unit	OFF, ON
EDP.EOLDLY#2	EOLDLY	Port end-of-line delay, in 0.1 second intervals	0–255
EDP.PRNMSG#2	PRNMSG	Displays print message	OFF, ON
EDP.RESPONSE#2	RESPNS	Specifies whether the port transmits replies to serial commands	OFF, ON
EDP.SFMT#2	SFMT	Stream format	Alphanumeric, max length: 200
EDP.TERMIN#2	TERMIN	Termination character	CR/LF, CR
EDP.TRIGGER#2	TRIGGE	Selects the operation of the port	COMAND, STRLFT, STRIND

Table 6-9. Ports – USBCOM Menu EDP Commands

6.1.12 Stream Tokens Menu

Command	Description	Default	Choices / Range
STR.GROSS	String transmitted for the <M> token for gross weight	G	Alphanumeric, max length: 8
STR.INVALID	String transmitted for the <S> token when weight is invalid	I	Alphanumeric, max length: 2
STR.MOTION	String transmitted for the <S> token when scale is in motion	M	Alphanumeric, max length: 2
STR.NEG	Character transmitted for the <P> token when the weight is negative	-	NONE, SPACE, -
STR.NET	String transmitted for the <M> token for net weight	N	Alphanumeric, max length: 8
STR.OK	String transmitted for the <S> token when the scale is ok	" "	Alphanumeric, max length: 2
STR.POS	Character transmitted for the <P> token when the weight is positive	SPACE	NONE, SPACE, +
STR.PRI	String transmitted for the <U> token for primary units	L	Alphanumeric, max length: 8
STR.RANGE	String transmitted for the <S> token when the scale is out of range	O	Alphanumeric, max length: 2
STR.SEC	String transmitted for the <U> token for secondary units	K	Alphanumeric, max length: 8
STR.TARE	String transmitted for the <M> token for tare weight	T	Alphanumeric, max length: 8
STR.ZERO	String transmitted for the <S> token when the scale is at center of zero	Z	Alphanumeric, max length: 2

Table 6-10. Stream Tokens EDP Commands

6.1.13 Feature Menu

Command	Menu	Description	Choices / Range
CONSNUM	CURVAL	Consecutive numbering	0–999999
CONSTUP	RESVAL	Consecutive number startup value	0–999999
DECFMT	DECFMT	Decimal format	DOT, COMMA
GRAVADJ	LOCALE	Locale - must be enabled for latitude and elevation	OFF, ON
LAT.LOC	LATUDE	Latitude (locale must be set to ON)	0-90
ELEV.LOC	ELEVAT	Elevation (locale must be set to ON)	-9999–9999
UID	UID	Unit ID	Alphanumeric, max length: 6
IRITECOMPATIBILITY	IRITE	Specifies the compatibility level for iRite programs NOTE: The iRite keypress handler changed in Firmware version 4.0. If using an existing iRite program that was written for Version 2X or 3X firmware, use the 2X3X setting. If starting an iRite program from scratch, use the 4X setting.	2X3X, 4X

Table 6-11. Feature EDP Commands

6.1.14 Regulatory Menu

Command	Menu	Description	Choices / Range
REGWORD	REGWRD	Term printed when weighing in gross mode	GROSS, BRUTTO
REGULAT	REGULA	Regulatory agency having jurisdiction over the scale site	NONE, OIML, NTEP, CANADA, INDUST
REG.AGENCY	AUDAG	Audit trail agency format	NONE, OIML, NTEP, CANADA
REG.BASE	OVRBASE	Zero preference for overload calculation; CALIB - calibrated zero; SCALE - push button zero	CALIB, SCALE
REG.CTARE	CTARE	CLEAR key – clear tare/accumulator while viewing	NO, YES
REG.RTARE	RTARE	Round push button tare to nearest display division	YES,NO
REG.KTARE	KTARE	Keyed tare	NO, YES
REG.MTARE	MTARE	Multiple tare action	NOTHIN, REPLAC, REMOVE
REG.NTARE	NTARE	Negative or zero tare	NO, YES
REG.PRTMOT	PRTMOT	Print while in motion	NO, YES
REG.PRINTPT	PRTPT	Add "PT" to keyed tare print	NO, YES
REG.SNPSHOT	SNPSHT	Selects display or scale weight source	DISPLAY, SCALE
REG.ZTARE	ZTARE	Remove tare on ZERO	NO, YES

Table 6-12. Regulatory EDP Commands

6.1.15 Time and Date Menu

Command	Menu	Description	Choices / Range
DATEFMT	DFORMT	Date format	MMDDY2, DDMMY2, Y2MMDD, Y2DDMM, MMDDY4, DDMMY4, Y4MMDD, Y4DDMM
DATESEP	D SEP	Date separator character	SLASH, DASH, SEMI
TIMEFMT	TFORMT	Time format	12HOUR, 24HOUR
TIMESEP	T SEP	Time separator character	COLON, COMMA

Table 6-13. Time and Date EDP Commands

6.1.16 Passwords Menu

Command	Menu	Description	Choices / Range
PWD.USER	USER	Used to protect items in the top level menu	0–999999
PWD.SETUP	SETUP	Used to protect items in the setup menu	0–999999

Table 6-14. Password EDP commands



NOTE: The EDP commands can be used to set the passwords but they will not return the current password setting.

6.1.17 Keypad Lock Menu







Command	Menu	Description	Choices / Range
KEYLCK.GROSSNET	GRSNET	Locks or unlocks 	LOCK, UNLOCK
KEYLCK.MENU	MENU	Locks or unlocks 	LOCK, UNLOCK
KEYLCK.PRINT	PRINT	Locks or unlocks 	LOCK, UNLOCK
KEYLCK.TARE	TARE	Locks or unlocks 	LOCK, UNLOCK
KEYLCK.UNITS	UNITS	Locks or unlocks 	LOCK, UNLOCK
KEYLCK.ZERO	ZERO	Locks or unlocks 	LOCK, UNLOCK

Table 6-15. Keypad Lock EDP Commands

6.1.18 Setpoints Menu



NOTE: For setpoint commands the “n” symbolizes the setpoint number, 1-20.

Command	Menu	Description	Choices / Range
SP.ACCESS#n	ACCESS	Setpoint access in top level menu (user)	OFF, ON
SP.BANDVAL#n	BNDVAL	Band value	0-999999
SP.BRANCH#n	BRANCH	Branch destination	0,1-20
SP.CLRACCM#n	CLRACM	Clear accumulator	OFF, ON
SP.CLRTAR#n	CLRTAR	Clear tare	OFF, ON
SP.DIGOUT#n	DIGOUT	Lists all digital output bits available for the specified SLOT	NONE, BIT1-BIT4
SP.END#n	END	Ending setpoint number for TIMER and CONCUR	1-20
SP.HYSTER#n	HYSTER	Hysteresis	0-65535 (for the COUNTR and DELAY setpoints); 0-999999 (for the GROSS, NET and %REL setpoints)
SP.KIND#n	Selection made after dropping down from SETPT x	Supported setpoint kinds	OFF, GROSS, NET, -GROSS, -NET, %REL, PAUSE, DELAY, WAITSS, COUNTR, AUTJOG, TIMER, CONCUR
SP.BATSEQ#n	BATSEQ	Specifies whether the setpoint is a batch step	OFF, ON
SP.NAME#n	NAME	Setpoint name string	Alphanumeric, max length: 6
SP.PCOUNT#n	PCOUNT	Preact learn interval (number of cycles before it learns)	0-65535
SP.PREACT#n	PREACT	Preact type	OFF, ON, LEARN
SP.PREADJ#n	PREADJ	Preact adjustment percentage	0-999999
SP.PRESTAB#n	PRESTB	Preact learn stability	0-65535
SP.PREVAL#n	PREVAL	Preact value	0-999999
SP.PSHACCM#n	PSHACM	Push accumulate	OFF, ON, ONQUIET
SP.PSHPRINT#n	PSHPRT	Push print	OFF, ON, WAITSS
SP.PSHTARE#n	PSHTAR	Push tare	OFF, ON
SP.RELNUM#n	RELNUM	Relative setpoint number	1-20
SP.SENSE#n	SENSE	Digital output sense	NORMAL, INVERT
SP.DSLOT#n	SLOT	Digital output slot	NONE, SLOT0, SLOT1
SP.START#n	START	Starting setpoint number for TIMER and CONCUR	1-20
SP.TRIP#n	TRIP	Specifies when the setpoint is satisfied when compared to value	HIGHER, LOWER, INBAND, OUTBAND
SP.VALUE#n	VALUE	Setpoint value	0-65535 (for the COUNTR and DELAY setpoints) 0-999999 (for the GROSS, NET and %REL setpoints)
BATCHNG	BATCHG	Batching mode	OFF, AUTO, MANUAL

Table 6-16. Setpoints EDP Commands



NOTE: Different setpoint parameters are available and accepted depending on KIND, TRIP, and PRACT. These restrictions are listed below by the EDP command name but the same applies to access by menu.

6.1.18.1 GROSS, NET, -GROSS, -NET and %REL Type Setpoints

SP.KIND#n=GROSS, NET, -GROSS, -NET, or %REL
SP.ACCESS#n
SP.BNDVAL#n (if TRIP INBAND or OUTBAND only)
SP.BRANCH#n (if BATSEQ is ON)
SP.CLRACCM#n
SP.CLRTARE#n
SP.DIGOUT#n
SP.HYSTER#n (if TRIP HIGHER or LOWER only)
SP.BATSEQ#n
SP.NAME#n
SP.PCOUNT#n (if PRACT is LEARN only)
SP.PRACT#n (if TRIP HIGHER or LOWER only)
SP.PREADJ#n (if PRACT is LEARN only)
SP.PRESTAB#n (if PRACT is LEARN only)
SP.PREVAL#n (if PRACT is ON or LEARN only)
SP.PSHACM#n
SP.PSHPRT#n
SP.PSHTAR#n
SP.RELNUM#n (for %REL setpoints only)
SP.SENSE#n
SP.SLOT#n
SP.TRIP#n
SP.VALUE#n

6.1.18.2 PAUSE Type Setpoints

SP.KIND#n=PAUSE
SP.ACCESS#n
SP.DIGOUT#n
SP.NAME#n
SP.SENSE#n
SP.SLOT#n

6.1.18.3 DELAY Type Setpoints

SP.KIND#n=DELAY and AUTJOG

SP.ACCESS#n

SP.CLRACCM#n

SP.CLRTARE#n

SP.DIGOUT#n

SP.NAME#n

SP.PSHACM#n

SP.PSHPR#n

SP.PSHTAR#n

SP.SENSE#n

SP.SLOT#n

SP.VALUE#n

6.1.18.4 WAITSS Type Setpoints

SP.KIND#n=WAITSS

SP.ACCESS#n

SP.CLRACCM#n

SP.CLRTARE#n

SP.DIGOUT#n

SP.NAME#n

SP.PSHACCM#n

SP.PSHPRINT#n

SP.PSHTARE#n

SP.SENSE#n

SP.SLOT#n

6.1.18.5 COUNTR Type Setpoints

SP.KIND#n=COUNTR

SP.ACCESS#n

SP.BRANCH#n

SP.DIGOUT#n

SP.NAME#n

SP.SENSE#n

SP.SLOT#n

SP.VALUE#n

6.1.18.6 TIMER and CONCUR Setpoints

SP.KIND#n=TIMER and CONCUR

SP.ACCESS#n

SP.DIGOUT#n

SP.END#n

SP.NAME#n

SP.SLOT#n

SP.START#n

SP.SENSE#n

SP.VALUE#n

6.1.19 Print Format Menu

The Menu items (except for HDRFMT) are listed by the format and the sub-parameters.

Command	Menu	Description	Choices / Range
ACC.FMT	ACCFMT FMT	Accumulator enabled and displayed, or setpoint print operation with PSHACCM=ON	Alphanumeric, max length: 1000
ACC.PORT	ACCFMT PORT	Accumulator print port	COM, USBCOM, CHAN 1, CHAN 2, ETH-S, ETH-C, USBMEM, OFF
GFMT.FMT	GFMT FMT	Weigh mode, no tare in system	Alphanumeric, max length: 1000
GFMT.PORT	GFMT PORT	Weigh mode, no tare in system, print port	COM, USBCOM, CHAN 1, CHAN 2, ETH-S, ETH-C, USBMEM, OFF
HDRFMT1	HDRFMT	Must be inserted into other print format	Alphanumeric, max length: 300
NFMT.FMT	NFMT FMT	Weigh mode, tare in system	Alphanumeric, max length: 1000
NFMT.PORT	NFMT PORT	Weigh mode, tare in system, print port	COM, USBCOM, CHAN1, CHAN 2, ETH-S, ETH-C, USBMEM, OFF
SPFMT.FMT	SPFMT FMT	Setpoint print operation with PSHPRT=ON	Alphanumeric, max length: 1000
SPFMT.PORT	SPFMT PORT	Setpoint print port	COM, USBCOM, CHAN 1, CHAN 2, ETH-S, ETH-C, USBMEM, OFF

Table 6-17. Print Format EDP Commands

6.1.20 Digital I/O Configuration Menu

Command	Menu	Description
DIO.b#s	BIT x	OFF, PRINT, ZERO, TARE, UNITS, CLEAR, DSPACC, DSPTAR, NT/GRS, CLRCN, BATRUN, BATSTR, BATPAS, BATRST, BATSTP, OUTPUT, KBDLOC, GROSS, NET, PRIM, SEC, CLRTAR, CLRACC, INPUT, PROGIN

Table 6-18. Digital I/O Configuration EDP Commands



NOTE: Digital inputs and outputs are specified by bit number (b = 1-4 for slot 0 or slot 1 relay option; or 1-24 for slot 1 24-channel DIO option) and slot number (s = 0 or 1).

6.1.21 Analog Out Menu

Command	Menu	Description	Choices / Range
ALG.SOURCE#1	SOURCE	Specifies source of the analog output control; SCALE: indicates that the analog output will follow the configured Mode based on scale data; PROGIN: indicates that the analog output is under iRite program control	SCALE, PROGIN
ALG.MODE#1	MODE	Specifies weight data, gross or net, tracked by the analog output	GROSS, NET
ALG.OUTPUT#1	OUTPUT	Specifies the output type	0-10V, 0-20MA, 4-20MA
ALG.ERRACT#1	ERRACT	Error action	FULLSC, HOLD, ZEROSC
ALG.MIN#1	MIN	Minimum value tracked	0-999999
ALG.MINNEG#1	MINNEG	Specify ON if the minimum weight is a negative value	OFF, ON
ALG.MAX#1	MAX	Maximum value tracked	0-999999
ALG.MAXNEG#1	MAXNEG	Specify ON if the maximum weight is a negative value	OFF, ON

Table 6-19. ALGOUT EDP Commands

6.1.22 Weigh Mode Commands

The weigh mode commands, see [Table 6-20](#), transmit data to a data communications port on demand. The SX, EX, and all the X weight retrieval commands are valid only in normal operating mode; all other commands are valid in either setup or weigh mode.

Command	Function
CONSNUM	Set or query the consecutive number
UID	Set or query the unit ID
SD	Set or query the date; enter six-digit date using the year-month-day order specified for the DATEFMT parameter, using only the last two digits of the year
ST	Set or query the time; enter the time using 24-hour format
SX#n	Start serial port streaming; if port is configured to stream on port #1–4 (1=COM, 2=USBCOM, 3=Ethernet Server, 4=Ethernet Client, 5=Serial Card Channel 1, 6=Serial Card Channel 2)
SX	Start serial port streaming for the port receiving the command, if port is configured to stream
EX#n	Stop serial port streaming; if port is configured to stream on port #1–4 (1=COM, 2=USBCOM, 3=Ethernet Server, 4=Ethernet Client, 5=Serial Card Channel 1, 6=Serial Card Channel 2)
EX	Stop serial port streaming for the port receiving the command, if port is configured to stream
RS	Reset system; this is a soft reset; used to reset the indicator without resetting the configuration to the factory defaults
S	Sends a single stream frame from the scale to the port in the format defined by the Stream Format parameter of the port receiving the command
XA#n	Transmit accumulator value in displayed units for scale n
XA	Transmit accumulator value in displayed units for selected scale
XAP#n	Transmit accumulator value in primary units for scale n
XAS#n	Transmit accumulator value in secondary units for scale n
XG#n	Transmit gross weight in displayed units for scale n
XG	Transmit gross weight in displayed units for selected scale
XG2	Transmit gross weight in non-displayed units for selected scale
XGP#n	Transmit gross weight in primary units for scale n
XGS#n	Transmit gross weight in secondary units for scale n
XN#n	Transmit net weight in displayed units for scale n
XN	Transmit net weight in displayed units for selected scale
XN2	Transmit net weight in non-displayed units for selected scale
XNP#n	Transmit net weight in primary units for scale n
XNS#n	Transmit net weight in secondary units for scale n
XT#n	Transmit tare weight in displayed units for scale n
XT	Transmit tare weight in displayed units for selected scale
XT2	Transmit tare weight in non-displayed units for selected scale
XTP#n	Transmit tare weight in primary units for scale n
XTS#n	Transmit tare weight in secondary units for scale n
XE	Returns a decimal representation of any error conditions (Table 10-3 on page 108)
XEH	Returns a hexadecimal representation of any error conditions (Table 10-3 on page 108)

Table 6-20. Weigh Mode EDP Commands



NOTE: The 880 only supports one scale.

6.1.23 Digital I/O Control Menu

Command	Function
DON.b#s	Set digital output on (active) at bit b, slot s
DOFF.b#s	Set digital output off (inactive) at bit b, slot s
DIN.#s	A value is returned that is the sum of all active bits, no matter how they are configured, for the specified slot.

Table 6-21. Digital I/O Control EDP Commands



NOTE: Digital inputs and outputs are specified by bit number (b = 1-4 for slot 0 or slot 1 relay option; or 1-24 for slot 1 24-channel DIO option) and slot number (s = 0 or 1).

The DON/DOFF commands will only control the state of the a slot/bit that is defined as an OUTPUT in the configuration menu.

6.1.24 Batching Control Commands

Command	Function
BATSTART	Batch start; if the BATRUN digital input is active (low) or not assigned, the BATSTART command can be used to start the batch program; if the BATRUN is inactive (high), the BATSART command will reset the batch program to the first batch step
BATSTOP	Batch stop; stops the batch program at the current batch step and turns off all associated digital outputs
BATPAUSE	Batch pause; stops the batch program at the current step; all digital outputs set on by the current step (except for those set by concur setpoints) are set off; the BATSTR digital input or BATSTART serial command can be used to restart the batch program at the current step
BATRESET	Batch reset; stops the program and resets the batch program to the first batch step; run the BATRESET command after making changes to the batch configuration
BATSTATUS	Batch status; returns XYYY where X is S (if the batch is stopped), P (if the batch is paused), R (if the batch is running) and YYY is the setpoint number the batch is currently on (1-20)

Table 6-22. Batching Control Commands

6.1.25 Database Commands

The commands listed in Table 6-23 can be used to create and maintain databases in the 880. Except for the DB.DELALL command, all of the database commands require an extension to identify the database number.

Command	Description
DB.ALIAS.n#x	Get or set database name
DB.CLEAR.n#x	Clear database contents
DB.DATA.n#x	Get or set database contents
DB.SCHEMA.n#x	Get or set database structure
db.delall	Delete all databases and database contents
	<ul style="list-style-type: none"> n represents the database number, x is 0 Each command must be terminated with a carriage return character (<CR>, ASCII 13) The 880 only supports onboard databases - slot 0 Onboard database number 1 is reserved for future use on the 880; database numbers 2-9 are available

Table 6-23. Database Commands

db.alias

The DB.ALIAS command is used to get or set the alias used by iRite programs to reference the specified database.

Each database alias must be unique among all databases and adhere to the following rules: eight character maximum; must begin with an alpha character or an underscore; can only contain A–Z, a–z, 0–9, or an underscore (_).

The following command assigns an alias of TRUCKS_2 to the second database in the onboard memory:

```
DB.ALIAS.2#0=TRUCKS_2<CR>
```

Sending the DB.ALIAS command alone, without assigned data, returns the current database alias.

db.clear

To clear the contents of a database, send the following command:

```
DB.CLEAR.n#x<CR>
```

Where:

n is the database number within the memory

x is the slot number 0

The 880 responds with OK<CR> if the command is successful, ??<CR> if unsuccessful.

db.data

The DB.DATA command can be used to send data to or retrieve data from the 880.

Data can be sent to the indicator using the following command:

```
DB.DATA.n#x = data{ | }<CR>
```

Where:

n is the database number within the memory

x is the slot number 0

data represents a single cell of a row of data

{ | } is an ASCII pipe character (decimal 124), used to delimit cell data. If the data being sent is not the last cell of the row, append the pipe character to the data to indicate that more data is coming for that particular row. If the data being sent is the last cell of the row, do not append the pipe character.

If the command is accepted, the 880 responds with OK<CR>; if not, it responds with ??<CR>.

The following commands place the data shown in [Table 6-24](#) into the second database in the onboard memory:

```
DB.DATA.2#0=this|<CR>
```

```
DB.DATA.2#0=is|<CR>
```

```
DB.DATA.2#0=a|<CR>
```

```
DB.DATA.2#0=test<CR>
```

```
DB.DATA.2#0=aaa|<CR>
```

```
DB.DATA.2#0=bbb|<CR>
```

```
DB.DATA.2#0=ccc|<CR>
```

```
DB.DATA.2#0=ddd<CR>
```

Record	Cell			
	1	2	3	4
First	this	is	a	test
Second	aaa	bbb	ccc	ddd

Table 6-24. Sample Database Contents

Sending the DB.DATA command alone, without assigned data, returns the database contents:

```
DB.DATA.n#x<CR>
```

The 880 responds with the entire contents of the database. Returned data is cell-delimited with the pipe character (decimal 124) and row-delimited with carriage returns (decimal 13).

For example, the following command could be used to return the contents of database 2 in the onboard memory:

```
DB.DATA.2#0<CR>
```

If the database contents are the records shown in [Table 6-24](#), the indicator responds with the following data, using pipe characters and carriage returns to delimit the database cells and rows, respectively:

```
this|is|a|test<CR>aaa|bbb|ccc|ddd<CR>
```

Determine the number of records currently in the database both prior to and after sending the DB.DATA command to verify that the correct number of records are received. The number of records can be determined with the DB.SCHEMA command.



NOTE: The 62K of onboard (slot 0) memory can be allocated to up to eight databases. The size of any one database may limit the size and number of other databases. There is not an end of database notification at the end of the DB.DATA command transmission. Use a receive time-out to determine command completion. The time-out value will vary based on baud rate.

db.schema

The DB.SCHEMA command is used to get or set the structure of a database.

DB.SCHEMA.n#x<CR>

The 880 responds to the command above by returning the following:

<Max Records>,<Current Record Count>,
<Column Name>,<Data Type>,<Data Size>,...<CR>

The <Column Name>, <Data Type>, and <Data Size> elements repeat for each column in the database.

The <Column Name> follows the rules for alias names: 8 character maximum; must begin with an alpha character or an underscore; can only contain A–Z, a–z, 0–9, or an underscore (_).

The <Data Type> is represented by a numeric field:

Value	Type
1	Byte
2	Short (16-bit integer)
3	Long (32-bit integer)
4	Single (32-bit floating point)
5	Double (64-bit floating point)
6	Fixed string
7	Variable string
8	Date and time

Table 6-25. Data Type Field Codes

The <Data Size> value must match the data type. A range of data size values is allowed only for the string data types. The maximum number of characters allowed for the string field are listed below.

Size	Value
Byte	1
Short	2
Long	4
Single	4
Double	8
Fixed string	1–255
Variable string	1–255
Date and time	8

Table 6-26. Data Size Field Codes

The DB.SCHEMA command can also be used to modify the schema, but only when the indicator is in setup mode and only if the database does not contain any data.

7.0 Print Formatting

The 880 provides five print formats. Formats GFMT and NFMT will be printed based on the current mode of operation when the Print key is pressed, see [Table 7-2 on page 94](#). HDRFMT can be inserted into any other print format using the <H1> formatting token. SPFMT is printed when a setpoint is satisfied if PSHPRT is set to ON or WAITSS in the setpoint configuration. The ACCFMT is printed if the accumulator is embedded and the print key is pressed while viewing the accumulator value, or if a setpoint PSHACM is set to ON. If PSHACM is set to ONQUIE, it will accumulate, but not print.

Each print format can be customized to include up to 1000 characters of information (300 for HDRFMT), such as company name and address. Use the indicator front panel (PFORMT menu), EDP commands, or the Revolution configuration utility to customize the print formats.

7.1 Print Formatting Tokens

[Table 7-1](#) lists tokens that can be used to format the 880 print formats. Tokens included in the format strings must be enclosed between < and > delimiters. Any characters outside of the delimiters are printed as text. Text characters can include any ASCII character that can be printed by the output device.

Tokens	Description	Ticket Format	
		GFMT/NFMT/ ACCFMT	SPFMT
<G>	Gross weight in displayed units, see notes 1 and 2	X	X
<N>	Net weight in displayed units, see notes 1 and 2	X	X
<T>	Tare weight in displayed units, see notes 1 and 2	X	X
<A>	Accumulated weight in displayed units	X	X
<AC>	Number of accumulator event (five-digit counter)	X	X
<AT>	Time of last accumulator event	X	X
<AD>	Date of last accumulator event	X	X
<SCV>	Setpoint captured value	--	X
<STV>	Setpoint target value	--	X
<SPM>	Setpoint mode (gross or net label)	--	X
<SNA>	Setpoint name	--	X
<SN>	Setpoint number	--	X
<SPV>	Setpoint preact value	--	X
<TI>	Time	X	X
<DA>	Date	X	X
<TD>	Time and date	X	X
<UID>	Unit ID number, see note 3	X	X
<CN>	Consecutive number, see note 3	X	X
<H1>	Ticket header (HDRFMT)	X	X
<NL nn >	New line (nn = number of termination (<CR/LF> or <CR>) characters), see note 4	X	X
< nnn >	ASCII character (nnn = decimal value of ASCII character); used for inserting control characters (STX, for example) in the print stream	X	X
<SP nn >	Space (nn = number of spaces), see note 4	X	X
<SU>	Toggle weight data format (formatted/unformatted), see note 5	X	X
<AN>	Alibi ticket number	X	X
<US nn >	Insert user print text string (from iRite user program, SetPrintText API)	X	X
<EV x >	Invoke iRite user program print handler x (PrintFmt x)	X	X
<CR>	Carriage return character	X	X
<LF>	Line feed character	X	X

Table 7-1. Print Format Tokens



NOTE: Gross, net, and tare weights are eight digits in length, including sign and decimal point, followed by a space and a one- to five-digit units identifier. Total field length with units identifier is 10-14 characters. Depending on what units are configured, the units identifier will be lb, kg, oz, tn, t, or g.

Gross, net, tare, and accumulator weights can be printed in any configured weight units by adding the following modifiers to the gross, net, tare, and accumulator weight commands: /P (primary units), /D (displayed units), /S (secondary units), /T (tertiary units). If not specified, the current displayed units (/D) is assumed. Example: To format a ticket to show net weight in secondary units, use the following command: <N/S>.

Unit ID and consecutive number (CN) fields are 1–6 characters in length, as required.

If nn is not specified, 1 is assumed. Value must be in the range 1–99.

After receiving an SU token, the indicator sends unformatted data until the next SU token is received. Unformatted data omits decimal points, leading and trailing characters.

7.2 Default Print Formats

Table 7-2 shows the default print formats for the 880 and lists the conditions under which each print format is used. The HDRFMT format is used to specify header information that can be used by the other print formats. The contents of the HDRFMT format can be inserted into any other print format using the <H1> formatting token.

Format	Default Format String	Used When
GFMT FMT	GROSS<G><NL2><TD><NL>	Weigh mode, no tare in system
GFMT PORT	--	Defines the communication port that the format will be sent to
NFMT FMT	GROSS<G><NL>TARE<SP><T><NL> >NET<SP2><N><NL2><TD><NL>	Weigh mode, tare in system
NFMT PORT	--	Defines the communication port that the format will be sent to
ACCFMT FMT	ACCUM<A><NL><DA> <TI><NL>	Accumulator enabled and displayed, or setpoint print operation with PSHACCM=ON
ACCFMT PORT	--	Defines the communication port that the format will be sent to
SPFMT FMT	<SCV><SP><SPM><NL>	Setpoint push print operation (PSHPRNT=ON or WAITSS)
SPFMT PORT	--	Defines the communication port that the format will be sent to

Table 7-2. Default Print Formats



NOTE: In OIML and CANADA modes, the letters PT (preset tare) are automatically inserted after the printed tare weight. If the COM port is set to TYPE = RS485, the port will not perform a demand print.

7.3 Customizing Print Formats

The following sections describe procedures for customizing print formats using the EDP commands, the front panel (PFORMAT menu), and the Revolution configuration utility.

7.3.1 Using the EDP Commands

With a personal computer, terminal, or remote keyboard attached to the 880, the EDP command set can be used to customize the print format strings.

To view the current setting of a format string, type the name of the print format, followed by .FMT, and press ENTER. For example, to check the current configuration of the GFMT format, type GFMT.FMT and press ENTER. The indicator responds by sending the current configuration for the gross format:

```
GROSS<G><NL2><TD><NL>
```

To change the format, use the format EDP command followed by an equals sign (=) and the modified print format string. For example, to add the name and address of a company to the gross format, send the following EDP command:

```
GFMT.FMT=RICE LAKE WEIGHING SYSTEMS<NL>230 W COLEMAN ST<NL>RICE LAKE WI 54868<NL2><G>
GROSS<NL>
```

A ticket printed using this format might look like the following:

```
RICE LAKE WEIGHING SYSTEMS
230 W COLEMAN ST
RICE LAKE WI 54868
1345 LB GROSS
```

The ticket above could also be formatted by specifying the company address information in the HDRFMT ticket format, then substituting the <H1> token for the address in the GFMT ticket format:

```
HDRFMT1=RICE LAKE WEIGHING SYSTEMS<NL>230 W COLEMAN ST<NL>RICE LAKE WI
54868<NL2>GFMT=<AE><G> GROSS<NL>
```



NOTE: The HDRFMT1 command does not require the .FMT.

7.3.2 Using the Front Panel



NOTE: If there is no access to equipment for communication through the communication ports or when working at a site where such equipment cannot be used, the PFORMAT menu, see [Section 3.2.13 on page 61](#), can be used to customize the print formats. Using the PFORMAT menu, edit the print format strings by changing the decimal values of the ASCII characters in the format string.

Some special characters cannot be displayed on the 880 front panel, see [Section 10.9 on page 116](#), and are shown as blanks. The 880 can send or receive any ASCII character; the character printed depends on the particular ASCII character set implemented for the receiving device.

7.3.3 Using Revolution

The Revolution configuration utility provides a print formatting grid with a tool bar. The grid allows the construction of the print format without the formatting tokens (<NL> and <SP>) required by the front panel or EDP command methods. Using Revolution, type text directly into the grid, then select weight value fields from the tool bar and place them where they are to appear on the printed ticket.

8.0 Setpoints

The 880 indicator provides 20 configurable setpoints for control of both indicator and external equipment functions. Setpoints can be configured to perform actions or functions based on specified parameter conditions. Parameters associated with various setpoint kinds can, for example, be configured to perform functions (print, tare, accumulate), to change the state of a digital output to control external equipment functions, or to make conditional decisions.



NOTE: See [Section 3.2.14 on page 62](#) for setpoint menu layout.
Weight-based setpoints are tripped by values specified in primary units only.

8.1 Batch and Continuous Setpoints

880 setpoints can be either continuous or batch setpoints.

Continuous setpoints are free-running; the indicator constantly monitors the condition of free-running setpoints at each A/D update. The specified setpoint action or function is performed when the designated setpoint parameter conditions are met. A digital output or function assigned to a free-running setpoint continuously changes state, becoming active or inactive, as defined by the setpoint parameters.

Batch setpoints are active one at a time, in an ordered sequence. The 880 can use setpoints to control up to 20 separate batch processing steps.

A digital output associated with a batch setpoint is active until the setpoint condition is met, then latched for the remainder of the batch sequence.

To use batch setpoints, the BATCHG parameter in the SETPTS menu must be set to auto or manual. AUTO sequences repeat continuously after receiving a single initial BATSTR signal. MANUAL sequences require a BATSTR signal each time a single batch is run. The BATSTR signal can be initiated by a digital input, serial command or the StartBatch function in an iRite program. Set the BATCHG parameter to OFF to disable batch setpoints.

For setpoint kinds that can be used as either continuous or batch setpoints, the BATSEQ parameter must also be set ON. (Setpoint kinds that can only be used as batch setpoints do not require the BATSEQ parameter.) If the setpoint is defined but the BATSEQ parameter is off, the setpoint operates as a continuous setpoint, even during batch sequences.



NOTE: In applications that contain both batch setpoint routines and continuous setpoints, continuous setpoints should be kept separate from the batch sequence. This is especially true when using CONCUR or TIMER setpoints to perform actions or functions based on the batch sequence. CONCUR and TIMER setpoints should not be included in the referenced START and END setpoint sequence.

Kind	Description	Batch	Continuous
OFF	Setpoint turned off/ignored	--	--
GROSS	Gross setpoint; performs functions based on the gross weight; the target weight entered is considered a positive gross weight	X	X
NET	Net setpoint; performs functions based on the net weight; the target weight entered is considered a positive net weight value	X	X
-GROSS	Negative gross weight; performs functions based on the gross weight; the target weight entered is considered a negative gross weight	X	X
-NET	Negative net weight; performs functions based on the net weight; the target weight entered is considered a negative net weight value	X	X
%REL	Percent relative setpoint; performs functions based on a specified percentage of the target value of a referenced setpoint, using the same weight mode as the referenced setpoint; the actual target value of the %REL setpoint is calculated as a percentage of the target value of the referenced setpoint	X	X
PAUSE	Pauses the batch sequence indefinitely; a BATSTR signal must be initiated to continue the batch process	X	--
DELAY	Delays the batch sequence for a specified time; the length of the delay (in tenths of a second) is specified by the VALUE parameter	X	--
WAITSS	Wait for standstill. Suspends the batch sequence until the scale is at standstill	X	--

Table 8-1. Setpoint Kinds

Kind	Description	Batch	Continuous
COUNTR	Specifies the number of consecutive batch sequences to perform; counter setpoints should be placed at the beginning of a batch routine	X	--
AUTJOG	Auto Jog – automatically checks the previous weight-based setpoint to verify the setpoint weight value is satisfied in a standstill condition; if the previous setpoint is not satisfied when at standstill, the AUTJOG setpoint activates the digital output of the previous weight-based setpoint for a period of time, specified by the VALUE parameter; the autjog process repeats until the previous weight-based setpoint is satisfied when the scale is at standstill NOTE: The AUTJOG digital output is typically used to signify that an autjog operation is being performed. AUTJOG should not be assigned to the same digital output as the related weight-based setpoint.	X	--
TIMER	Tracks the progress of a batch sequence based on a timer; the timer value, specified in tenths of a second on the VALUE parameter, determines the length of time allowed between start and end setpoints; the indicator START and END parameters are used to specify the start and end setpoints; if the END setpoint is not reached before the timer expires, the digital output associated with this setpoint is activated	--	X
CONCUR	Allows a digital output to remain active over a specified portion of the batch sequence; two types of concur setpoints can be configured: Type 1 (VALUE=0): the digital output associated with this setpoint becomes active when the START setpoint becomes the current batch step and remains active until the END setpoint becomes the current batch step; Type 2 (VALUE > 0): if a non-zero value is specified for the VALUE parameter, that value represents the timer, in tenths of a second, for this setpoint; the digital output associated with this setpoint becomes active when the START setpoint becomes the current batch step and remains active until the timer expires	--	X

Table 8-1. Setpoint Kinds (Continued)

8.2 Batch Operations

Batches are controlled by digital inputs or EDP commands.

Batch Run (BATRUN digital input)

If a BATRUN digital input is configured, it must be active (low) for a batch to be started, and for it to continue to run. If a batch is running and the input becomes inactive (high), it will stop the batch at the current batch setpoint and turn off all associated digital outputs.

Batch Start (BATSTR digital input or BATSTART EDP command)

If the BATRUN digital input is active (low), or is not assigned, batch start will start a batch, resume a paused batch or resume a stopped batch. If the BATRUN digital input is inactive (high), batch start will reset the current batch.

Batch Pause (BATPAS digital input or BATPAUSE EDP command)

The BATPAS digital input will pause an active batch, turning off all associated digital outputs EXCEPT those associated with CONCUR and TIMER setpoints, while the input is active (low). As soon as the BATPAS digital input is made inactive (high), the batch will resume.

BATPAUSE EDP command works the same, except the batch will not resume until a batch start signal is received.

Batch Stop (BATSTP digital input or BATSTOP EDP command)

Stops an active batch at the current setpoint and turns off all associated digital outputs.

Batch Reset (BATRST digital input or BATRESET EDP command)

Stops and resets an active batch to the beginning of the process.



WARNING: To prevent personal injury and equipment damage, software-based interrupts must always be supplemented by emergency stop switches and other safety devices necessary for the application.

8.2.1 Batching Switch

The batching switch option, PN 19369, comes as a complete unit in an FRP enclosure, with legend plate, locking stop switch (mushroom button), and a run/start/abort three-way switch.

Both switches are wired into the indicator's digital I/O terminal strip as shown in Figure 8-1. Each switch uses a separate digital input. Digital input #1 must be set to BATSTR and #2 must be set to BATRUN.

Once cables and switches have been connected to the indicator, use the setup switch to place the indicator in configuration mode. Use the Digital I/O menu, see Section 3.2.16 on page 67 to configure digital input and output functions.

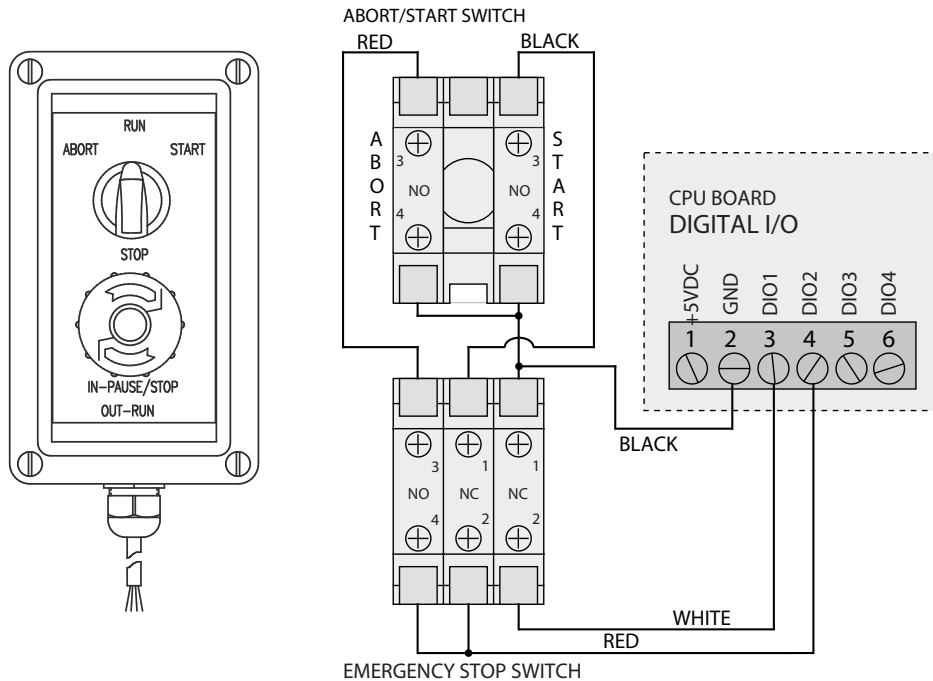

Figure 8-1. Batching Switch and Wiring Diagram Example

When configuration is complete, exit configuration mode. Initialize the batch by turning the three-way switch to **ABORT**, then unlock the STOP button (the STOP button must be in the OUT position to allow the batch process to run). The batching switch is now ready to use.

To begin a batch process, turn the three-way switch to **START** momentarily. If the STOP button is pushed during the batch process, the process halts and the button locks in the IN position.

The **START** switch is ignored while the STOP button is locked in the IN position. The STOP button must be turned counterclockwise to unlock it, then released into the OUT position to enable the three-way switch.

To restart an interrupted batch from the step where it left off, do the following:

1. Unlock STOP button (OUT position).
2. Turn three-way switch to **START**.

To restart an interrupted batch from the first batch step, do the following:

1. Turn three-way switch to **ABORT**.
2. Unlock STOP button (OUT position).
3. Turn three-way switch to **START**.



NOTE: Use this procedure (or the **BATRESET** serial command) to initialize the new batch routine following any change to the setpoint configuration.

8.3 Batching Examples



NOTE: DIGIO, SLOT 0, BIT 1 = BATSTR
DIGIO, SLOT 0, BIT 2, 3 and 4 = OUTPUT

Example 1

The following example is used to dispense 100 lb drafts, automatically refilling a hopper to 1000 lb gross weight once the gross weight has dropped below 300 lb.

Setpoint 1 ensures that the hopper has enough material to start the batch. If the hopper weight is 100 lb or higher, setpoint 1 is tripped.

```
KIND=GROSS
VALUE=100
TRIP=HIGHER
BATSEQ=ON
```

Setpoint 2 waits for standstill, performs a tare, and puts the indicator into net mode.

```
KIND=WAITSS
PSHTAR=ON
```

Setpoint 3 is used to dispense material from the hopper. When the hopper weight goes below 100 lb net the setpoint is tripped.

```
KIND=-NET
VALUE=100
TRIP=LOWER
BATSEQ=ON
SLOT = SLOT 0
DIGOUT=2
```

Setpoint 4 is used to evaluate the gross weight of material in the hopper after dispensing. When the hopper weight falls below 300 lb, digital output slot 0, bit 3, becomes active and the hopper is refilled to 1000 lb.

```
KIND=GROSS
VALUE=300
TRIP=HIGHER
HYSTER=700
BATSEQ=ON
SLOT = SLOT 0
DIGOUT=3
```

Setpoint 5 is used as a “no flow alarm”. If the process in setpoint 5 is not completed in 10 seconds, digital output slot 0, bit 4, becomes active to signify a problem.

```
KIND=TIMER
VALUE=100
START=3
END=4
SLOT = SLOT 0
DIGOUT=4
```

Example 2

The following example uses a CONCUR setpoint to provide a two-speed simultaneous fill of a hopper to a net weight of 1000 lb.

Setpoint 1 ensures that the gross weight is within 50 lb of gross zero.

```
KIND=GROSS  
VALUE=0  
TRIP=INBAND  
BNDVAL=50  
BATSEQ=ON
```

Setpoint 2 performs a tare once the scale is at standstill.

```
KIND=WAITSS  
PSHTARE=ON
```

Setpoint 3 uses digital output slot 0, bit 2, to fill a hopper to a net weight of 800 lb.

```
KIND=NET  
VALUE=800  
TRIP=HIGHER  
BATSEQ=ON  
SLOT = SLOT 0  
DIGOUT=2
```

Setpoint 4 uses digital output slot 0, bit 3, to fill the hopper to a net weight of 1000 lb.

```
KIND=NET  
VALUE=1000  
TRIP=HIGHER  
BATSEQ=ON  
SLOT = SLOT 0  
DIGOUT=3
```

Setpoint 5 operates digital output slot 0, bit 3, while Setpoint 3 is active, providing simultaneous two-speed filling.

```
KIND=CONCUR  
VALUE=0  
START=3  
END=4  
SLOT = SLOT 0  
DIGOUT=3
```

9.0 Ethernet and USB

The following section provides an overview of Ethernet and USB configuration.

9.1 Ethernet Server/Client Connections

The 880 supports two simultaneous TCP connections, one as a server and the other as a client. This section details the functions of the Server and Client connections, including some examples on how they may be used. Refer to [Section 3.2.10 on page 58](#) for configuration.



IMPORTANT: *If the indicator is on a network that has PoE capable Power Sourcing Equipment (PSE), the PSE must be IEEE 802.af or 802.2.at compliant. Any PSE that uses passive (always on) technology will damage the Ethernet port, because it is not designed to act as an Ethernet PoE Powered Device.*

9.1.1 Ethernet Server

The server features a configurable TCP Port number. It also has settings for echo, response, End-of-Line delay, trigger function, timeout, and stream data format.

A typical application may connect software (a terminal program such as Telnet, or Revolution) to the 880.

The 880 listens for a connection request from an external client device.

9.1.2 Ethernet Client

The client features the ability to open a TCP connection to a configurable remote server IP and TCP port.

If a connection has not been made and the 880 attempts to send data through the client connection, it will attempt to establish a connection to the remote server. It will continue trying indefinitely until a connection is made.

Typical applications for the client include connecting to a:

- Ethernet printer or remote display
- Remote TCP to serial device server
- Software that is listening for the connection

The client also has settings for echo, response, End-of-Line delay, trigger function, timeout, and stream data format.



NOTE: *Only a single connection each to the server and client is allowed at one time. If a connection is already established, other connection attempts will fail.*

The server and client ports are independent of each other, and both can have a connection at the same time. This means it can be streaming out one port, while using a computer to poll data from the other. Data can be streamed out both ports if desired (for best results, set the End-of-Line delay on both ports to at least 2).

Establishing connections - a client must establish a connection to a server. Therefore, the 880 cannot connect to a remote client, and a remote server cannot connect to the 880.

Both the server and client connections have a timeout parameter, allowing the 880 to terminate either connection after the set number of seconds has passed with no activity (0 = no disconnect).

When connecting to a DHCP network, it may take several seconds before the 880 is assigned an IP address. When a new IP address is assigned through DHCP, it is stored in the 880 configuration and will remain the IP address used until reconfigured manually; the indicator settings are reset to default; or a new address is assigned by DHCP.

9.1.3 Direct Connection from Computer to 880 Ethernet Server Without a Network (Ad-Hoc)

1. The computer must be configured with a static IP address. Using the computer's network configuration tools, configure the network adapter to have a static IP address and appropriate subnet mask.

Example: 192.168.0.100.

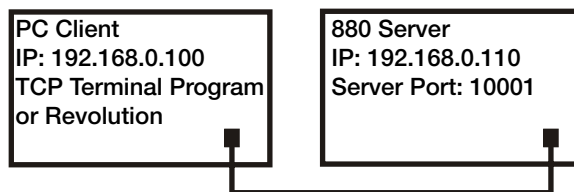

Figure 9-1. Direct Connection from Computer to 880 Ethernet

The 880 must also be configured with a static IP address, different from the computer's, but in the same subnet.

- Enter the configuration mode using the setup switch on the back of the 880, see [Figure 3-1 on page 44](#)
- Navigate to the ethernet sub-menu under the ports menu, see [Figure 3-11 on page 55](#)
- Set Dynamic Host Configuration Protocol (DHCP) to OFF, then configure the IP address and Subnet Address
Example: 192.168.0.110. Also set the Server Ethernet TCP Port number, if needed (default is 10001).

2. Connect an Ethernet straight-through or crossover cable (the port is auto-sensing, so either will work) between the 880 and the Ethernet connector on the computer.
3. Open the computer application that will be used.
4. To establish the connection, enter the indicator's IP address and Server TCP Port number. The application will now be able to communicate to the 880 using any of its EDP commands.

9.1.4 Computer Connection to 880 Ethernet Server Through a Network Switch or Router



NOTE: In some cases, devices cannot be connected to an existing network without the network administrator's approval. Ensure the computer has permissions to connect to a network. If there is any doubt as to what needs to be done, seek help from the networks administrator.

1. The computer should already be connected to the network, and either assigned an IP address using DHCP, or have a static address.

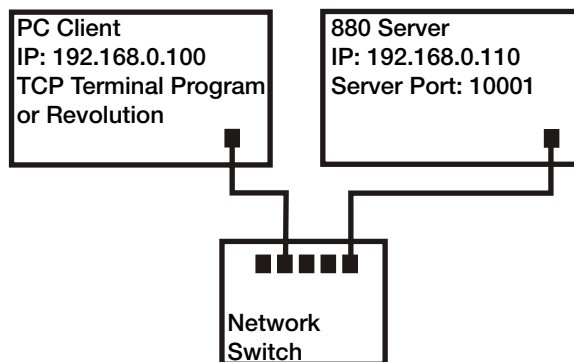

Figure 9-2. Connection from Computer to 880 Ethernet Through a Network Switch or Router

- If not, use the computer's network configuration tools to connect to the network
- If it is not a DHCP network, make note of the computer's IP address and subnet mask

2. The 880 can either be configured to obtain its IP address automatically using DHCP (if supported on the network), or it can be configured manually with a Static IP. It is recommended to use DHCP, if available.
 - To configure the settings, go into the configuration mode using the setup switch on the back of the unit, see [Figure 3-1 on page 44](#)
 - Navigate to the Ethernet sub-menu under the ports menu, see [Figure 3-11 on page 55](#)
 - Dynamic Host Configuration Protocol (DHCP): set the DHCP Setting to ON; set the Ethernet server TCP port to the desired port number (default is 10001); the IP, subnet, primary and secondary DNS, and default gateway will be configured automatically when the 880 is connected to the DHCP-enabled network
 - Manual (static) IP (IPADRS): set DHCP to OFF, then configure the IP address and subnet address; for example, *192.168.0.110*; also set the Ethernet server TCP port number, if needed (default is 10001); the primary and secondary DNS, and default gateway, can be set if needed
3. Using a straight-through or crossover cable (the port is auto-sensing, so either will work) connect the Ethernet connector on the 880 to an available connector on the network.
4. If connected to a DHCP-enabled network and DHCP is enabled, go back into the configuration mode and navigate to the IP setting to get the IP address the network assigned to the 880. Make note of the current IP address, being careful not to change any of the numbers. Return to weigh mode.
5. Open the computer application to be used. To establish the connection, enter the indicator's IP address and server TCP port number (192.168.0.110 - or the DHCP-assigned IP address - and 10001). The application will now be able to communicate to the 880 using any of its EDP commands.

9.1.5 Connection to a Remote Host - Demand Print to an Ethernet Printer

1. Connect the 880 and printer either directly to each other (each with a Static IP on the same subnet), or through a network.

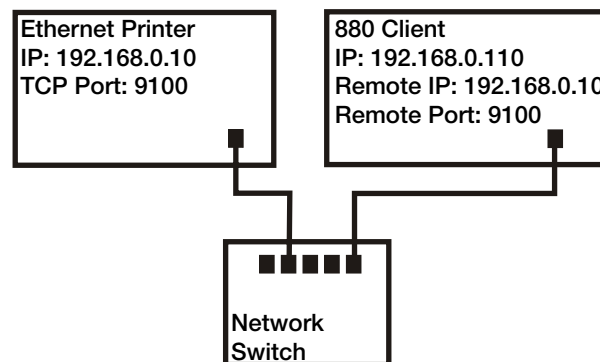

Figure 9-3. Connection to Remote Host

2. Configure the Client Remote Server IP and port to the IP address and TCP port of the printer.
3. Configure the destination port of the Print Format(s) being used to Ethernet Client (ETH-C).
4. Set the Ethernet Client Trigger (TRIGGE) to Command (COMAND) mode.
5. If the client has not been connected and a demand print is called for, the Client will attempt connection to the Printer. This may take several seconds. Once the connection is made, the print data will be sent to the printer.

The connection will remain intact unless the 880 or the printer terminates the connection. The 880 has a timeout setting for the Client connection. The timeout feature is useful when several indicators want to print to the same printer.

- When set to 0, the connection will not be terminated by the 880
- When set to a value other than zero, the connection will be terminated after inactivity for the specified period of time, in seconds

9.1.6 Connecting to a Remote Host - Stream weight data to an Ethernet Remote Display

1. Connect the 880 and Remote Display either directly to each other (each with a Static IP on the same subnet), or through a network.

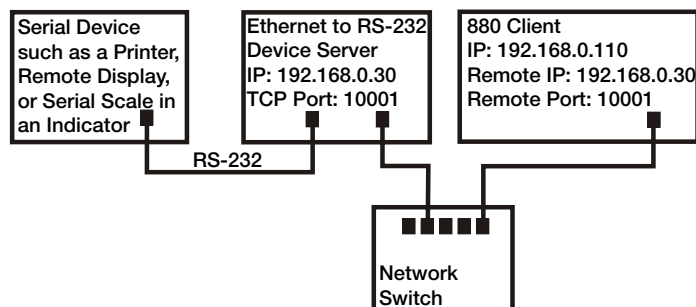

Figure 9-4. Stream or Demand Data to a Remote Ethernet to RS232 Device Server

2. Configure the client remote server IP and port to the IP address and TCP port of the remote display.
3. Configure the trigger setting for the client to either Stream Industrial (STRIND), or Stream Legal-for- Trade (STRLFT).
4. To prevent data overrun on the receiving device (the 880 will stream data at up to 50 frames per second), it is recommended the client's End-of-Line delay be set to 1 (10 frames per second) or 2 (5 frames per second), or higher. This is also a good way to help reduce network traffic if speed is not a concern. If data at the remote display appears to lag, or get behind the data on the indicator, the End-of-Line delay may need to be increased even more.
5. Shortly after returning to weigh mode, the 880 will start to stream data to the Ethernet client port. The 880 will attempt to make the connection. The data will be sent to the remote host once connected. This may take several seconds.



NOTE: There may be several seconds worth of buffered data sent at the moment of connection.

9.1.7 Connecting to a Remote Host, Stream/Demand Data to Remote Ethernet-to-RS-232 Device Server

1. Connect the 880 and device server either directly to each other (each with a static IP on the same subnet), or through a network.
2. Configure the client remote server IP and port to the IP address and TCP port of the device server.
3. Configure the trigger setting for the client to either command mode (COMAND), stream industrial (STRIND), or stream Legal-for-Trade (STRLFT), depending on the application.
4. Connect the serial output of the device server to the serial device set to send or receive data through the Ethernet connection.



NOTE: In this configuration, the 880 has to initiate the connection.

Using Revolution with Ethernet

1. Use one of the methods shown in [Section 9.1.3 on page 102](#) or [Section 9.1.4 on page 102](#) to connect the 880 to the computer with Revolution installed.
2. In Revolution, after opening the 880 module, select **Tools**, then **Options**.
3. Set the default communications to TCP/IP and select **OK**.
4. Under the **Communications** menu, select **Connect**.
5. Revolution will request the IP address and port number. Enter them and select **OK**.
6. Revolution will attempt to establish communications with the indicator. If the connection is successful, Revolution is ready to use to upload and download configuration settings.



NOTE: When using Revolution with Ethernet, the Timeout setting for the 880 Ethernet Server should be set to 0 to prevent the 880 from terminating the connection.

If the connection was unsuccessful, re-check all network settings, both on the computer and in the 880. Also try to 'ping' the IP address of the 880 to verify the computer and 880 are both able to communicate on the network.

9.2 USB Host

9.2.1 Using a USB Keyboard

A USB keyboard will be detected when it is connected, no configuration is required.

Key	Options	Description
Caps Lock	Off On	Press key to toggle between On/Off; when on, alpha keys will display in upper case; not user configurable
Num Lock	On Off	Press key to toggle between On/Off; when on, numeric keypad will be available; not user configurable
Arrows	--	Used to navigate through the menu
Alphanumeric	--	Available when a string prompt is open
Numeric	--	Available when a numeric prompt is open
Modifiers	Ctrl Alt Shift	Modify another key press; there is no difference between the left and right modifier keys <i>Example: shift + a displays an "A" to the application.</i>

Table 9-1. USB Keyboard Key Descriptions

Key	Alt Key	Function
F1	--	No base function but can be received by iRite
F2	--	No base function but can be received by iRite
F3	--	No base function but can be received by iRite
F4	--	No base function but can be received by iRite
F5	--	No base function but can be received by iRite
F6	Alt+z	Zero key
F7	Alt+g	Gross/Net key
F8	Alt+t	Tare key
F9	Alt+u	Units key
F10	Alt+p	Print key
F11	--	Not used
F12	--	Menu key
Esc	--	Cancel key
Print Screen	--	Print key
Home	--	Home key (move to the start of a string entry)
End	--	End key (move to the end of a string entry)
Delete	--	Delete key (delete the current character and move any trailing characters left one character; if it was the last character in a string then move the character highlight left one position)
Backspace	--	Clear key (deletes the character in the left most digit location of the display)

Table 9-2. USB Keyboard Function Keys



NOTE: In weigh mode, with no prompt open, enter a numeric value and press Tare on the 880 to perform a keyed tare. On a keyboard press F8 or Alt + t.

When editing a string, a keyboard can be used to directly edit the string while at the top level. Pressing any alphanumeric key will insert the appropriate character in the current position. If the down arrow key is pressed (either on the 880 or the keyboard) then the left/right arrow keys will be used move through the characters.

When a USB keyboard is connected - Indicator front panel key operations can be performed on both the 880 keypad and the USB keyboard.

These keyboard keys will have no function within the 880: Scroll Lock, Page Up, Page Down, Insert, Tab, Windows Key and Application Key.

9.2.2 USB Memory storage

A USB memory storage device can be used to save the 880 configuration to a file or to load configuration from a file. Saving or loading configuration is done in the configuration mode using the Load and Save menu items located in the Ports menu under the Setup Menu, see [Figure 3-14 on page 59](#) for more information.

9.2.2.1 Saving Configuration

1. Connect the **USB** memory device to the indicator.
2. Press the setup switch, see [Figure 3-1 on page 44](#) for setup switch information, to enter configuration mode.
3. Press ◀ or ▶ until **PORTS** displays.
4. Press ▾, **COM** displays.
5. Press ◀ or ▶ until **USB** displays.
6. Press ▾, **LOAD** displays.
7. Press ▶ **SAVE?** displays.
8. Press  to save configuration. The display will say **Busy**. When save is complete, **Saved** will display momentarily, then display will return to **Save?**

9.2.2.2 Loading Configuration

To load a configuration file, use a USB memory device with an appropriate configuration file on it.

The file will either be a 880_<UID>.txt or 880_<UID>.rev file (UID matches the Unit ID of the Indicator).



NOTE: If the Unit ID does not match, the indicator will not load the file.

1. Connect the USB memory device to the indicator.
2. Press the setup switch, see [Figure 3-1 on page 44](#), to enter configuration mode.
3. Press ◀ or ▶ until **Ports** displays.
4. Press ▾, **COM** displays.
5. Press ◀ or ▶ until USB displays
6. Press ▾, **Load** displays.
7. Press ▾, **All?** displays.
8. Press ◀ or ▶ to the desired parameter.
 - **All?** to load all parameters
 - **Cfg?** to load all except calibration
 - **Cal?** to load just calibration
9. Press  to load the selected configuration. The display will say **Busy**. When load is complete, **Loaded** will be displayed momentarily, then display will return to the previous selection.

9.2.2.3 Printing to a Text File on a USB Flash Drive

Demand prints can be sent to a file on a USB flash drive installed in the USB host port.

1. Set the **PORT** setting to **USBMEM** for each of the print formats to be sent to the flash drive.
2. Insert a USB flash drive in the USB host port (J5).

Whenever a print format is called to print, a file will be created on the USB flash drive named PRINT_<UID>.txt, where UID is the unit ID of the indicator. If the file already exists, the data will be appended to the current file.

If there is an error writing data to the flash drive, **USBERR** will display momentarily each time a print is attempted. Remove and reinstall the USB flash drive to restore operation.

If a USB flash drive is not installed, nothing will be printed.

10.0 Appendix

10.1 Error Messages

The 880 indicator provides a number of error messages. When an error occurs, the message is shown on the indicator display. Error conditions can also be checked remotely by using the XE EDP command as described in [Section 10.4 on page 108](#).

10.1.1 Displayed Error Messages

The 880 provides a number of front panel error messages to assist in problem diagnosis. [Table 10-1](#) lists these messages and their meanings.

Error Message	Description	Solution
— — — —	Over range (upper dashes)	Check for improper load cell wiring, configuration, calibration, scale hardware problems
— — — —	Under range (lower dashes)	
— — — —	A/D out of range (center dashes); or if using local/remote (serial scale) - loss of serial scale data	
CFGERR	Configuration error on power up if there was an error loading configuration	Press the Enter key to reboot the indicator
ERROR	Internal program error	Check configuration
HWFERR	Hardware failure error on failure to write to the EEPROM any error (except for a battery error or an accumulation over range error) when exiting the menu	Press the Enter key to reboot the indicator
LOBATT	The low battery error message flashes every 30-seconds when the battery is low	Replace the battery
NOTARE	Tare is prevented because of regulatory mode settings, the configuration of the TAREFN parameter, motion on the scale, and others	Change regulatory mode settings or the TAREFN parameter
RANGE	A numeric value entered in configuration mode is out of the acceptable range; the error is displayed momentarily – then parameter being edited is displayed so the value can be corrected	Re-enter a value that is in range for the parameter being edited
NO ZERO	Zero is prevented (due to regulatory mode settings, motion on the scale, zero range settings)	Check zero settings and for motion

Table 10-1. 880 Error Messages

10.2 Status Messages

The EDP command **P** can be used to provide status about the indicator.

- The **P** EDP command returns whatever is currently shown in the indicator's primary display area

PPPPPP uu

Where:

- PPPPPP** is the information shown on the primary display
- uu** is the two-digit units annunciator

If the indicator is in an underrange or overload condition, the weight value is replaced with **&&&&&&** (overload) or **.....** (underrange).

10.3 Using the HARDWARE Command

The HARDWARE serial command can be used to verify that installed option cards are recognized by the system.

The HARDWARE command returns a three-digit card code, representing the card installed:

ID Number	Description
000	No card installed
032	24 Channel Digital I/O Card
085	Relay Card
097	Dual Serial Card
101	USB Host Option
153	Analog Output Card
170	CompactCom Card

Table 10-2. HARDWARE Command Option Card Type Codes

If an installed card is not recognized (HARDWARE command returns code of 000), ensure that the card is seated properly. Reinstall the card, if necessary, then cycle the power to read the configuration again. If the card is still not recognized, try a different option card.

10.4 ERROR Commands Output

The XE and XEH commands return a representation of any existing error conditions as described in the following table. If more than one error condition exists, the number returned is the sum of the values representing the error conditions. The XE command returns the value as a decimal representation and the XEH command returns the value as a hexadecimal representation.

XE Error Code (Decimal)	Description	XE Error Code (Hexadecimal)
0	No errors	0x00000000
1	VIRGERR	0x00000001
2	PARMCHKERR	0x00000002
4	LOADCHKERR	0x00000004
8	PRINTCHKERR	0x00000008
16	ENVRAMERR	0x00000010
32	ENVCRCERR	0x00000020
64	BATTERYERR	0x00000040
128	TCPERR	0x00000080
32768	GRAVERR	0x00008000
65536	ADPHYSICALERR	0x00010000
131072	TAREERR	0x00020000
262144	EACCOVER	0x00040000
524288	STRINGERR	0x00080000
1048576	RESERVED_PF	0x00100000
2097152	RTCERR	0x00200000
4194304	MISSINGHWERR	0x00400000
8388608	CFGCONFLICTERR	0x00800000
16777216	UNRECOVERABLEERR	0x01000000

Table 10-3. Error Commands Output

10.5 TARE and ZERO Key Functions

The function of the front panel **Tare** and **Zero** keys depend on the value specified for the REGULA parameter in the FEATUR menu, see [Figure 3-9 on page 51](#).

[Table 10-4](#) describes the function of these keys for each of the regulatory modes.

REGULAT Parameter Value	Weight on Scale	Tare in System	Front Panel TARE Key or KTARE Command (TAREFN – Tare Function Setting)			Front panel ZERO key or KZERO command
			KEYED	PBONLY	BOTH	
NTEP	Zero or Negative	No	Keyed Prompt (1)	No Action	Keyed Prompt (1)	Zero
		Yes	Keyed Prompt (2)	Clear tare	Keyed Prompt (2)	Zero
	Positive	No	Keyed Prompt (1)	Tare	Tare	Zero
		Yes	Keyed Prompt (2)	Tare	Tare	Zero
CANADA	Zero or Negative	No	Keyed Prompt (1)	No Action	Keyed Prompt (1)	Zero
		Yes	Keyed Prompt (2)	Clear Tare	Keyed Prompt (2)	Zero
	Positive	No	No Action	Tare	Tare	Zero
		Yes	No Action	No Action	No Action	Zero
OIML	Zero or Negative	No	Keyed Prompt (1)	No Action	Keyed Prompt (1)	Zero
		Yes	Keyed Prompt (2)	Clear tare	Keyed Prompt (2)	Zero and Clear Tare (3)
	Positive	No	Keyed Prompt (1)	Tare	Tare	Zero
		Yes	Keyed Prompt (2)	Tare	Tare	Zero and Clear Tare (3)
NONE	Zero or Negative	No	Keyed Prompt (1)	Tare	Keyed Prompt (1)	Zero
		Yes	Keyed Prompt (2)	Clear Tare	Keyed Prompt (2)	Zero
	Positive	No	Keyed Prompt (1)	Tare	Tare	Zero
		Yes	Keyed Prompt (2)	Clear Tare	Clear tare	Zero

Table 10-4. TARE and ZERO Key Functions for REGULA Parameter Settings



NOTE: Entering a Zero tare will cancel the entry. Any other value will be accepted as a Keyed Tare.

Entering a Zero tare will clear the current Tare. Any other value will be accepted as a Keyed Tare.

The indicator will Zero and Clear the Tare only if the gross weight is within ZRANGE. No action is taken if the weight is outside of ZRANGE.

[Table 10-5](#) lists the sub-parameters available when configuring a scale using INDUST mode. The table includes the default values of the INDUST sub-parameters and the effective (not configurable) values used by NTEP, CANADA, OIML and NONE regulatory modes

REGULA/INDUST Parameter		REGULA Mode				
Parameter	Description	INDUST	NTEP	CANADA	OIML	NONE
SNPSHT	Display or scale weight source	DISPLAY	DISPLAY	DISPLAY	DISPLAY	SCALE
ZTARE	Remove tare on ZERO	NO	NO	NO	YES	YES
KTARE	Always allow keyed tare	YES	YES	NO	YES	YES
MTARE	Multiple tareaction	REPLAC	REPLAC	NOTHIN	REPLAC	REMOVE
NTARE	Allow negative tare	NO	NO	NO	NO	YES
CTARE	Allow CLEAR tare to clear tare	YES	YES	YES	NO	YES
RTARE	Round push button tare to nearest display division	YES	YES	YES	NO	YES
PRTMOT	Allow print while in motion	NO	NO	NO	NO	YES
PRTPT	Add PT to keyed tare print	NO	NO	YES	YES	NO
OVRBAS	Zero base for overload calculation	CALIB	CALIB	CALIB	SCALE	CALIB

Table 10-5. REGULA/INDUST Mode Parameters, Comparison with Effective Values of Regulatory Modes

10.6 Data Formats

10.6.1 Stream Serial Data Format

If stream data transmission is configured for the communication ports (STRLFT or STRIND), by default the 880 sends data using the Rice Lake Weighing Systems serial data format (RS-232/RS-422) shown in Figure 10-1.

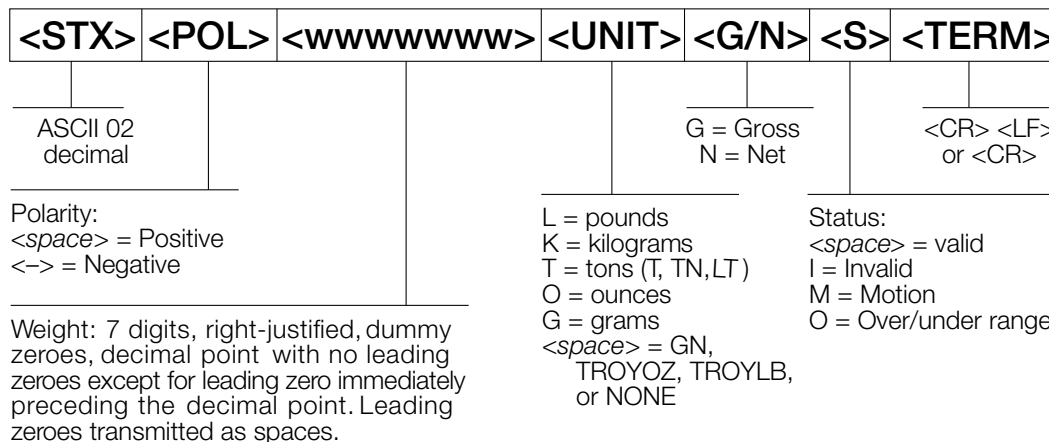

Figure 10-1. Stream Serial Data Format – RS-232 and RS-422

SFMT parameter default – <2><P><W7.><U><M><S><CR><LF>



NOTE: Format can be changed, see [Section 10.7 on page 112](#).

The character values can be changed for the stream format tokens, see [Table 6-10 on page 83](#).

If the COM port is set to TYPE = RS485, the port will not stream data, and cannot be used in a local/remote application, see [Section 10.6.2](#).

10.6.2 Print Output Serial Data Format

The 880 uses a data string format for a basic ticket printout. The print format is configured in the setup menu for the demand (print) port, and depends on the indicator configuration and mode, see [Section 7.0 on page 93](#) for print formatting.

Use the EDP commands, Revolution or the front panel to fully customize the print to work with a wide variety of printers, and other remote equipment.

10.6.3 RS-485 Data Formats

The 880 has a built-in RS-485 software protocol which is enabled when configuring a port's TYPE as 485. On the 880 the onboard COM port and the optional serial card ports have support for RS-485 communication.

All RS-485 communication with the 880 is via command and response. An external host must send a command and wait for a response.

All remote commands are initiated using the data format shown in [Figure 10-2](#):

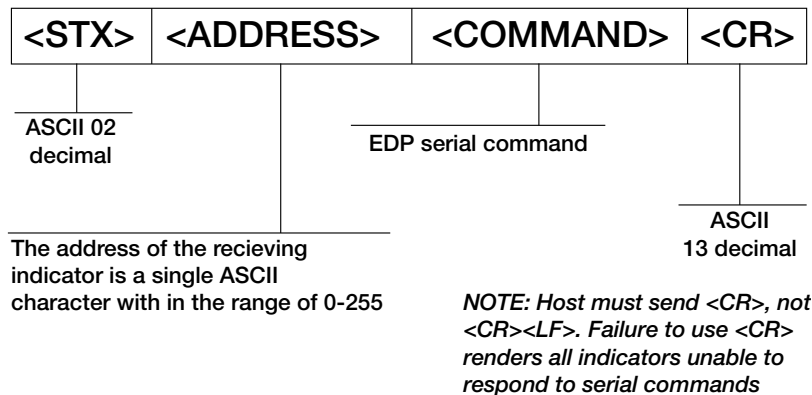

Figure 10-2. RS-485 Send Data Format

If the initiating device address matches the port address of a 880 on the RS-485 network, that indicator responds. The responding indicator uses the format shown in [Figure 10-3](#):

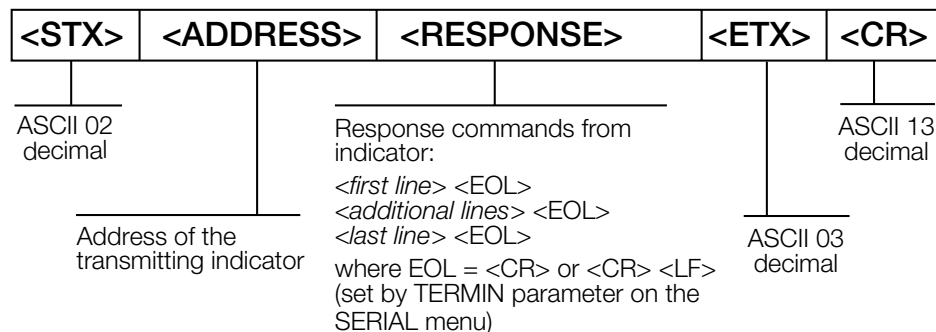

Figure 10-3. RS-485 Respond Data Format

```
<STX><ADDRESS><first line> <EOL>
<additional lines> <EOL>
<last line> <EOL><ETX><CR>
```

Where:

EOL- <CR> or <CR><LF> (set by the *TERMIN* parameter for the port)

Example: To send the XG#1 command from an ASCII terminal to an indicator at address 65 (decimal) on the RS-485 network, see [Figure 10-2](#) for proper formatting.

The keyboard equivalent for the start-of-text (STX) character is CONTROL-B, see [Table 10-10 on page 116](#).

The indicator address (65) is represented by an upper case "A".

The carriage return (CR) character is generated by pressing the **Enter** key.

Therefore, to send the XG#1 command to the indicator at address 65, enter the following at the terminal:

```
<CONTROL-B>AXG#1<CR>
```

The indicator will respond with <STX>A 1234.00 lb<CR><LF><ETX><CR>, see [Section 6.0 on page 77](#), for other commands that can be used.

10.7 Custom Stream Formatting – Input/Output

The format of the streamed data can be configured for the available ports individually using the front panel, EDP commands or Revolution using the tokens in [Table 10-6](#). Configuration is available for stream input/output tokens through EDP commands only; no front panel access is provided.

Format Identifier	Defined By	Description
<P[G N T]>	STR.POS STR.NEG	Polarity; outputs the positive or negative polarity label for the current or specified (Gross/Net/Tare) weight on the source scale; possible values are SPACE, NONE, + (for STR.POS) or – (for STR.NEG)
<U[P S T]>	STR.PRI STR.SEC STR.TER	Units; outputs the primary, secondary, or tertiary* units label for the current or specified (Primary/Secondary/Tertiary*) weight on the source scale
<M[G N T]>	STR.GROSS STR.NET STR.TARE	Mode; outputs the gross, net, or tare label for the current or specified weight (Gross/Net/Tare) on the source scale
<S>	STR.MOTION STR.RANGE STR.OK STR.INVALID STR.ZERO	Outputs the status for the source scale; default values and meanings for each status: STR.MOTION M In motion; STR.RANGE O Out of range; STR.OK <space> OK; STR.INVALID I Invalid; STR.ZERO Z COZ
<B [-]n,...>	See description below	Bit fields; comma-separated sequence of bit field specifiers; must be exactly 8 bits; minus sign ([–]) inverts the bit
B0	--	Always 0
B1	--	Always 1
B2	Configuration	=1 if even parity
B3	Dynamic	=1 if MODE=NET
B4	Dynamic	=1 if COZ (center of zero)
B5	Dynamic	=1 if motion
B6	Dynamic	=1 if displayed gross or net weight is negative
B7	Dynamic	=1 if out of range
B8	Dynamic	=1 if secondary/tertiary*
B9	Dynamic	=1 if tare in system
B10	Dynamic	=1 if tare is keyed
B11	Dynamic	=00 if MODE=GROSS =01 if MODE=NET =10 if UNITS=TERTIARY* =11 (not used)
B12	Dynamic	=00 if UNITS=PRIMARY =01 if UNITS=PRIMARY =10 if UNITS=PRIMARY =11 (note used)
B13	Configuration	=00 (not used) =01 if current DSPDIV=1 =10 if current DSPDIV=2 =11 if current DSPDIV=5
B14	Configuration	=00 (not used) =01 if primary DSPDIV=1 =10 if primary DSPDIV=2 =11 if primary DSPDIV=5
B15	Configuration	=00 (not used) =01 if secondary DSPDIV=1 =10 if secondary DSPDIV=2 =11 if secondary DSPDIV=5

Table 10-6. Custom Stream Format Identifiers

Format Identifier	Defined By	Description
B16	Configuration	=00 (not used) =01 if tertiary* DSPDIV=1 =10 if tertiary* DSPDIV=2 =11 if tertiary* DSPDIV=5
B17	Configuration	=000 (not used) =001 if current DECPNT=888880 =010 if current DECPNT=888888 =011 if current DECPNT=88888.8 =100 if current DECPNT=8888.88 =101 if current DECPNT=888.888 =110 if current DECPNT=88.8888 =111 if current DECPNT=8.88888
B18	Configuration	=000 (not used) =001 if primary DECPNT=888880 =010 if primary DECPNT=888888 =011 if primary DECPNT=88888.8 =100 if primary DECPNT=8888.88 =101 if primary DECPNT=888.888 =110 if primary DECPNT=88.8888 =111 if primary DECPNT=8.88888
B19	Configuration	=000 (not used) =001 if secondary DECPNT=888880 =010 if secondary DECPNT=888888 =011 if secondary DECPNT=88888.8 =100 if secondary DECPNT=8888.88 =101 if secondary DECPNT=888.888 =110 if secondary DECPNT=88.8888 =111 if secondary DECPNT=8.88888
B20	Configuration	=000 (not used) =001 if tertiary* DECPNT=888880 =010 if tertiary* DECPNT=888888 =011 if tertiary* DECPNT=88888.8 =100 if tertiary* DECPNT=8888.88 =101 if tertiary* DECPNT=888.888 =110 if tertiary* DECPNT=88.8888 =111 if tertiary* DECPNT=8.88888
<wspec [-] [0] digit[.].digit>	Scale weight	Weight for the source scale; wspec is defined as follows: wspec Indicates whether the weight is the current displayed weight; (W, w), gross (G, g), net (N, n), or tare (T, t) weight; upper-case letters specify right-justified weights; lower-case are left-justified; optional /P, /S, or /T suffixes can be added before the ending delimiter (>) to specify weight display in primary (/P), secondary (/S), or tertiary* (/T) units; [-] enter a minus sign (-) to include sign for negative values; [0] enter a zero (0) to display leading zeros digit[.].digit; the first digit indicates the field width in characters – range is 1–7; decimal point only indicates floating decimal; decimal point with following digit (range is 1–5) indicates fixed decimal with n digits to the right of the decimal; two consecutive decimals send the decimal point even if it falls at the end of the transmitted weight field
<CR>	--	Carriage return, hex 0x0D, ASCII decimal 13
<LF>	--	Line feed, hex 0x0A, ASCII decimal 10
<SPnn>	--	Space, nn = number of spaces; if nn is not specified, 1 is assumed; value must be in the range 1–99
<NLnn>	TERMIN setting of the port	New line, nn = number of termination (<CR/LF> or <CR>) characters; if nn is not specified, 1 is assumed; value must be in the range 1–99 NOTE: When streaming data, a configured End-of-Line Delay is performed after each New Line.
<nnn>	--	ASCII character (nnn = decimal value of ASCII character); used for inserting control characters (<002> for an STX, for example) in the output
* Tertiary (Range/Interval 3)		

Table 10-6. Custom Stream Format Identifiers (Continued)

10.8 Stream Formatting Examples

10.8.1 Toledo 8142 Indicator

Sample string for Toledo 8142 indicator (with no checksum):

<STX><Status Word A><Status Word B><Status Word C><wwwwww><ttttt><EOL>880 stream format configuration:
<02><B2, B0, B1, B13, B17><B2, B0, B1, B8, B5, B7, B6, B3><B2, B0, B1, B0, B0, B0, B0><W6><T6><CR>:

Identifier	Description
<STX>	The STX character is entered into the string using the <02> hex value
<Status Word A>	Toledo status words are made up of various bit fields; NOTE: Identifiers must be entered beginning with the high-order bit (bit 7-bit 0) of the Toledo status word. status Word A contains the following fields; equivalent 880 format identifiers are shown in parentheses; Bit 7: parity (B2) Bit 6: always 0 (B0) Bit 5: always 1 (B1) Bits 3–4: display divisions (B13) Bits 0–2: decimal format (B17)
<Status Word B>	Status Word B contains the following fields. Equivalent 880 format identifiers are shown in parentheses: Bit 7: parity (B2) Bit 6: always 0 (B0) Bit 5: always 1 (B1) Bit 4: lb/kg units (B8) Bit 3: stable/motion (B5) Bit 2: in/out-of-range (B7) Bit 1: pos/neg (B6) Bit 0: gross/net (B3)
<Status Word C>	Status Word C contains the following fields; equivalent 880 format identifiers are shown in parentheses: Bit 7: parity (B2) Bit 6: always 0 (B0) Bit 5: always 1 (B1) Bits 0–4: always 0 (B0)
<wwwwww>	The <W6> and <T6> indicate six digits of indicated weight and tare weight; valid characters are W, w, G, g, T, t, N, or n (lower case indicates left justified); W indicates current weight, G gross weight, N net weight, and T tare weight. /P and /S can be used to specify primary or secondary; minus indicates sign inclusion, and (0) indicates leading zeros; first digit indicates field width in characters; decimal indicates floating decimal point; decimal with subsequent digit indicates fixed decimal with <i>n</i> digits to the right of the decimal; two consecutive decimals (for example, <W06.>) send the decimal point even if it falls at the end of the transmitted weight field
<ttttt>	Tare weight, see description above
<EOL>	<CR> is entered at the end of the string as the end of line character in this example

Table 10-7. Toledo Sample String Identifiers

10.8.2 Cardinal 738 Indicator

Sample string for the Cardinal 738 indicator:

```
<CR><POL><wwwwww><S><SP><units><SP><G/N><SP><SP><EOL>
```

880 stream format configuration:

```
<CR><P><W07.><S><SP><U><SP><M><SP2><03>
```

Identifier	Description
<CR>	Carriage return
<POL>	Cardinal uses + for positive and – for negative, so the stream polarity tokens need to reflect this; the EDP commands for the 880 are STR.POS=+ and STR.NEG= –
<wwwwww>	The <W07.> identifier that the 880 recognizes indicates seven digits of weight with a decimal and leading zeros, with the decimal being sent at the end of the weight; valid characters are W, w, G, g, T, t, N, or n (lower case indicates left justified); W indicates current weight, G gross weight, N net weight, T tare weight. /P and /S can be used to specify primary or secondary; minus indicates sign inclusion, while (0) indicates leading zeros; first digit indicates field width in characters; decimal indicates floating decimal point; decimal with subsequent digit indicates fixed decimal with <i>n</i> digits to the right of the decimal; two consecutive decimals (for example, <W06.>) send the decimal point even if it falls at the end of the transmitted weight field
<S>	There are four possible tokens for status bits that can be used: motion, out-of-range, valid, and invalid; in the Cardinal, m indicates motion, o indicates out-of-range, and a space is used for valid or invalid weights; the commands to set these tokens in the 880 are STR.MOTION=m, STR.RANGE=o, STR.OK= , STR.INVALID= x
<SP>	Space
<units>	The Cardinal uses two-character, lower-case units identifiers; the commands to set these tokens in the 880 include: STR.PRI=lb (options: kg, g, tn, t, gr, oz, or sp), STR.SEC=kg (options: lb, g, tn, t, gr, oz, or sp)
<SP>	Space
<G/N>	The mode used for Cardinal is <i>g</i> for gross and <i>n</i> for net; these tokens are set using the STR.GROSS=g and STR.NET=n tokens
<SP>	Space
<SP>	Space
<EOL>	The end of line character is an ETX in this case so the hex value of <03> is entered in the string

Table 10-8. Cardinal Sample String Identifiers

10.8.3 Weightronix WI 120 Indicator

Sample string for the Weightronix WI120 indicator:

```
<SP><G/N><POL><wwwwww><SP><units><EOL>
```

880 stream format configuration:

```
<SP><M><P><W06.><SP><U><CR><LF>
```

Identifier	Description
<SP>	Space
<G/N>	The mode used for Weightronix is <i>G</i> for gross and <i>N</i> for net; these tokens are set using the STR.GROSS=G and STR.NET=N tokens
<POL>	Since the Weightronix uses + for positive and – for negative, the polarity tokens need to reflect this; the EDP commands for the 880 are STR.POS=+ and STR.NEG= –
<wwwwww>	The <W06.> that the 880 recognizes indicates six digits of weight with a decimal and leading zeros; valid characters are W, w, G, g, T, t, N, or n (lower case indicates left justified). W indicates current weight, G gross weight, N net weight, and T tare weight. /P and /S can be used to specify primary or secondary; minus indicates sign inclusion, while (0) indicates leading zeros; first digit indicates field width in characters; decimal indicates floating decimal point; decimal with subsequent digit indicates fixed decimal with <i>n</i> digits to the right of the decimal; two consecutive decimals (for example, <W06.>) send the decimal point even if it falls at the end of the transmitted weight field
<SP>	Space
<units>	The Weightronix uses two-character, lower-case units identifiers; the commands to set these tokens in the 880 include: STR.PRI=lb (options: kg, g, tn, t, gr, oz, or sp), STR.SEC=kg (options: lb, g, tn, t, gr, oz, or sp)
<EOL>	<CR> or <CR> and <LF>

Table 10-9. Weightronix Sample String Identifiers

10.9 ASCII Character Chart

Use the decimal values for ASCII characters listed in [Table 10-10](#) and [Table 10-11 on page 117](#) when specifying print format strings in the 880 PFORMT menu or serial stream formats. The actual character printed depends on the character mapping used by the output device.

The 880 can send or receive any ASCII character value (decimal 0–255). Due to limitations of the indicator display, some characters cannot be shown.

Control	ASCII	Dec	Hex	ASCII	Dec	Hex	ASCII	Dec	Hex	ASCII	Dec	Hex
Ctrl-@	NUL	00	00	space	32	20	@	64	40	'	96	60
Ctrl-A	SOH	01	01	!	33	21	A	65	41	a	97	61
Ctrl-B	STX	02	02	"	34	22	B	66	42	b	98	62
Ctrl-C	ETX	03	03	#	35	23	C	67	43	c	99	63
Ctrl-D	EOT	04	04	\$	36	24	D	68	44	d	100	64
Ctrl-E	ENQ	05	05	%	37	25	E	69	45	e	101	65
Ctrl-F	ACK	06	06	&	38	26	F	70	46	f	102	66
Ctrl-G	BEL	07	07	'	39	27	G	71	47	g	103	67
Ctrl-H	BS	08	08	(40	28	H	72	48	h	104	68
Ctrl-I	HT	09	09)	41	29	I	73	49	i	105	69
Ctrl-J	LF	10	0A	*	42	2A	J	74	4A	j	106	6A
Ctrl-K	VT	11	0B	+	43	2B	K	75	4B	k	107	6B
Ctrl-L	FF	12	0C	,	44	2C	L	76	4C	l	108	6C
Ctrl-M	CR	13	0D	-	45	2D	M	77	4D	m	109	6D
Ctrl-N	SO	14	0E	.	46	2E	N	78	4E	n	110	6E
Ctrl-O	SI	15	0F	/	47	2F	O	79	4F	o	111	6F
Ctrl-P	DLE	16	10	0	48	30	P	80	50	p	112	70
Ctrl-Q	DC1	17	11	1	49	31	Q	81	51	q	113	71
Ctrl-R	DC2	18	12	2	50	32	R	82	52	r	114	72
Ctrl-S	DC3	19	13	3	51	33	S	83	53	s	115	73
Ctrl-T	DC4	20	14	4	52	34	T	84	54	t	116	74
Ctrl-U	NAK	21	15	5	53	35	U	85	55	u	117	75
Ctrl-V	SYN	22	16	6	54	36	V	86	56	v	118	76
Ctrl-W	ETB	23	17	7	55	37	W	87	57	w	119	77
Ctrl-X	CAN	24	18	8	56	38	X	88	58	x	120	78
Ctrl-Y	EM	25	19	9	57	39	Y	89	59	y	121	79
Ctrl-Z	SUB	26	1A	:	58	3A	Z	90	5A	z	122	7A
Ctrl-[ESC	27	1B	;	59	3B	[91	5B	{	123	7B
Ctrl-\	FS	28	1C	<	60	3C	\	92	5C		124	7C
Ctrl-]	GS	29	1D	=	61	3D]	93	5D	}	125	7D
Ctrl-^	RS	30	1E	>	62	3E	^	94	5E	~	126	7E
Ctrl_	US	31	1F	?	63	3F	_	95	5F	DEL	127	7F

Table 10-10. ASCII Character Chart (Part 1)

ASCII	Dec	Hex	ASCII	Dec	Hex	ASCII	Dec	Hex	ASCII	Dec	Hex
Ç	128	80	á	160	A0	--	192	C0	a	224	E0
ü	129	81	í	161	A1	--	193	C1	b	225	E1
é	130	82	ó	162	A2	--	194	C2	G	226	E2
â	131	83	ú	163	A3	--	195	C3	p	227	E3
ä	132	84	ñ	164	A4	--	196	C4	S	228	E4
à	133	85	Ñ	165	A5	--	197	C5	s	229	E5
â	134	86	ª	166	A6	--	198	C6	m	230	E6
ç	135	87	º	167	A7	--	199	C7	t	231	E7
ê	136	88	¿	168	A8	--	200	C8	F	232	E8
ë	137	89		169	A9	--	201	C9	Q	233	E9
è	138	8A	¬	170	AA	--	202	CA	W	234	EA
ï	139	8B	½	171	AB	--	203	CB	d	235	EB
î	140	8C	¼	172	AC	--	204	CC	¥	236	EC
ì	141	8D	ì	173	AD	--	205	CD	f	237	ED
Ä	142	8E	«	174	AE	--	206	CE	Î	238	EE
Å	143	8F	»	175	AF	--	207	CF	Ç	239	EF
É	144	90	--	176	B0	--	208	D0	°	240	F0
æ	145	91	--	177	B1	--	209	D1	±	241	F1
Æ	146	92	--	178	B2	--	210	D2	³	242	F2
ô	147	93	--	179	B3	--	211	D3	£	243	F3
ö	148	94	--	180	B4	--	212	D4	ó	244	F4
ò	149	95	--	181	B5	--	213	D5	õ	245	F5
û	150	96	--	182	B6	--	214	D6	¸	246	F6
ù	151	97	--	183	B7	--	215	D7	»	247	F7
ÿ	152	98	--	184	B8	--	216	D8	°	248	F8
Ö	153	99	--	185	B9	--	217	D9	·	249	F9
Ü	154	9A	--	186	BA	--	218	DA	--	250	FA
¢	155	9B	--	187	BB	--	219	DB	--	251	FB
£	156	9C	--	188	BC	--	220	DC	--	252	FC
¥	157	9D	--	189	BD	--	221	DD	²	253	FD
Pts	158	9E	--	190	BE	--	222	DE	--	254	FE
f	159	9F	--	191	BF	--	223	DF	--	255	FF

Table 10-11. ASCII Character Chart (Part 2)

10.10 Digital Filtering

Digital filtering can be used to create a stable scale reading in challenging environments. The 880 has two filtering methods that can be set; sample rate and digital filter.

10.10.1 Sample Rate

The Sample rate should be set first. Better stability is achieved with a lower sample rate setting, so 7.5 Hz is more stable than 960 Hz.

10.10.2 Digital Filter

The digital filter is an adaptive filter that has two parameters to set the filter settling and response times: sensitivity and threshold.

Digital Filtering Sensitivity

Digital filtering sensitivity (DFSENS) controls the stability and settling time of the scale. The sensitivity parameter can be set to heavy, medium, or light. A heavy setting will result in an output that is more stable and will settle more slowly than that of light. However, small changes in weight data (a few grads) on the scale base will not be seen as quickly.

If the difference in typical subsequent weight values on the scale will be only a few grads, use a light setting. If using a truck scale where the changes in subsequent weight values will be 100s of grads, a heavy setting will be more appropriate.

Digital Filtering Threshold

With the digital filter threshold set at zero, determine the amount of instability that is present. Convert this instability to display divisions. The number of display divisions of instability will be used to set the threshold of the digital filter. The digital filter can be set to Off by entering 0 in the DFTHR parameter.

Digital filtering threshold (DFTHR) should be set for the amount of observed noise in the system. This parameter can be set in the range of 0 to 99999 display divisions. When a new sampled weight value is acquired, the adaptive filter compares the new value to the previous (filtered) output value. If the difference between the new value and the previous output value is greater than the DFTHR parameter (displayed division) the adaptive filter output is reset. The newly acquired sample value replaces the filtered output. If the difference between the new value and the previous output value is less than the DFTHR parameter, the two values are averaged together using a weighted average. The weighed average is based on the amount of the difference, time the system has been stable, and selected DFSENS value.

10.11 Analog Output Calibration





See [Section 3.0 on page 44](#) and [Table 3-18 on page 67](#) for ANALOG OUTPUT parameters.

The following calibration procedure requires a multimeter to measure voltage or current output from the analog output module. If the option is not already installed, install it in according to the instructions included with the option.

 **NOTE:** The analog output must be calibrated after the indicator itself has been configured, see [Section 3.0 on page 44](#) and [Section 4.0 on page 69](#).

1. Enter configuration mode and go to the ALGOUT menu, see [Figure 3-23 on page 68](#):
 - Set OUTPUT as desired for 0-10V, 0-20mA, or 4-20mA output

 **NOTE:** The minimum calibration occurs at 0.5 V and 1 mA for a 0-10 V and 0-20 mA output respectively.

- Set MIN to lowest weight value to be tracked by the analog output
 - Set MAX to highest weight value to be tracked by the analog output
2. Connect multimeter to connector J1 on the analog output board:
 - For voltage output, connect voltmeter leads to pins 3 and 4 (-V, +V)
 - For current output, connect ammeter leads to pins 1 and 2 (-mA, +mA)
3. Adjust zero calibration:
 - Scroll to the TWZERO parameter
 - Press ∇ , 000000 will display
 - Check voltage or current reading on multimeter
 - Set the parameter to match the reading from the multimeter
 - Press \triangleleft or \triangleright to select the digit
 - Press \triangle or ∇ to increment or decrement the value
 - Press  to move to the decimal point entry
 - Press \triangleleft or \triangleright to adjust the decimal point placement
 - Press  to accept the displayed value
 - CAL will be displayed while the calibration is being performed
4. Adjust span calibration:
 - Scroll to the TWSPAN parameter
 - Press ∇ , 000000 will display
 - Set the parameter to match the reading from the multimeter
 - Press \triangleleft or \triangleright to select the digit
 - Press \triangle or ∇ to increment or decrement the value
 - Press  to move to the decimal point entry
 - Press \triangleleft or \triangleright to adjust the decimal point placement
 - Press  to accept the displayed value
 - CAL will be displayed while the calibration is being performed
5. Verify calibration:
 - Return to the TWZERO/TWSPAN parameter and verify that the calibration has not drifted
 - Repeat calibration if needed
6. Return to weigh mode. Analog output function can be verified using test weights.

10.12 Option Card Firmware Update Procedure

The procedure to update firmware for option cards differs depending on the generation. The first generation option cards are green and must be returned to the facility for firmware updates.

The second generation cards are blue and can be updated in the field using a USB micro cable with Windows PC. If the process fails or a step is skipped, the hardware is not affected. Return to step 2 and repeat the process.

The state of the LEDs on the card do NOT change during the installation steps.

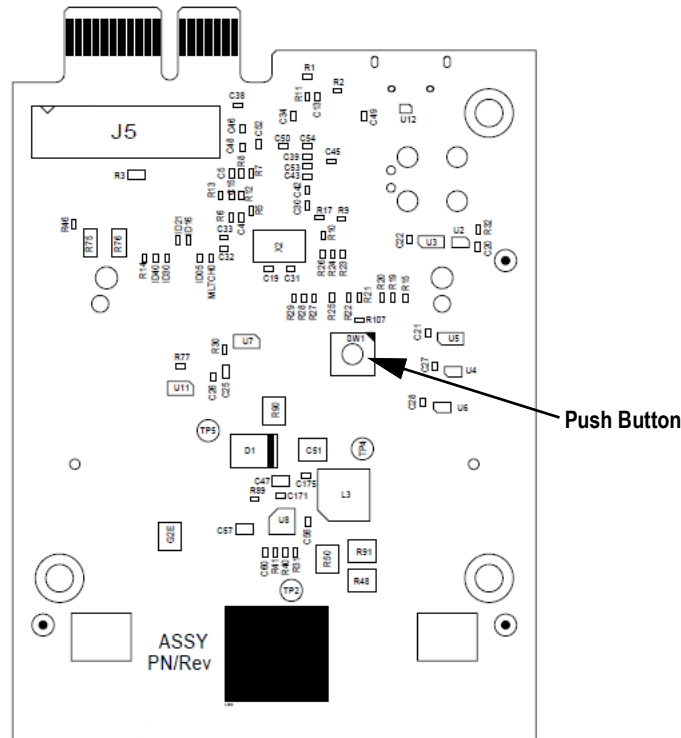





Figure 10-4. Push Button Location on the Anybus Host Card (PN 164756)

1. Download the second generation option card firmware *.bin file from ricelake.com/firmware to your PC.
2. Power down the 880.
3. Remove the second generation option card from the 880.
4. Attach the USB cable into PC.
5. Locate the push button on the card near the 880 backplane connector.
6. While holding down the card's push button, plug the USB micro end into the J4 connector (see Figure 10-4). PC detects a removable USB device called *CRP DISABLD*.
7. Release the push button after the USB device displays.
8. Access the newly attached device on the PC using a program such as Windows File Explorer.
9. Select the file **firmware.bin** and delete it.
10. Drag and drop to copy the downloaded second generation option card firmware to the attached device. Allow file to complete transfer.
11. Disconnect the drive in File Explorer.
12. Remove the USB cable connected to the second generation option card.
13. Disconnect the USB cable from the PC.
14. Unplug the USB cable from the second generation option card.
15. Replace the second generation option card into the same 880 slot it was removed from.
16. Power up 880.

Option Cards	Kit Part Number	Manual Part Number
Single Channel Ethernet/IP Interface	179159	200276
Dual Channel Ethernet/IP Interface	205566	
DeviceNet Interface	179162	200279
Single Channel Profinet Interface	179160	200277
Dual Channel Profinet Interface	205567	
Single Channel Modbus TCP Interface	179161	200278
Dual Channel Modbus TCP Interface	205568	
Profibus DP Interface	179163	200280
EtherCAT Interface	179158	200275

Table 10-12. Available Option Cards

11.0 Compliance

	EU DECLARATION OF CONFORMITY <i>EU-KONFORMITÄTSERKLÄRUNG DÉCLARATION UE DE CONFORMITÉ</i>		Rice Lake Weighing Systems 230 West Coleman Street Rice Lake, Wisconsin 54868 United States of America 
	Type/Typ/Type: 880 indicator series		
English	We declare under our sole responsibility that the products to which this declaration refers to, is in conformity with the following standard(s) or other regulations document(s).		
Deutsch	Wir erklären unter unserer alleinigen Verantwortung, dass die Produkte auf die sich diese Erklärung bezieht, den folgenden Normen und Regulierungsbestimmungen entsprechen.		
Français	Nous déclarons sous notre responsabilité que les produits auxquels se rapporte la présente déclaration, sont conformes à la/aux norme/s suivante ou au/aux document/s normatif/s suivant/s.		
EU Directive	Certificates	Standards Used / Notified Body Involvement	
2014/30/EU EMC	-	EN 55011:2009+A1:2010, EN 61326-1:2006	
2014/35/EU LVD	-	IEC 60950-1 ed.2	
2011/65/EU RoHS	-	EN 50581:2012	
Signature:			Place: <u>Rice Lake, WI USA</u>
Type Name:	<u>Richard Shipman</u>		Date: <u>May 3, 2019</u>
Title:	<u>Quality Manager</u>		

12.0 Specifications

Power

Line Voltages	100–240 VAC
Frequency	50 or 60 Hz
DC Voltages	12–24 VDC, LPS (Class 2) / PS2 powered
Power Consumption	AC: 15 W DC: 20 W

Analog Specifications

Excitation Voltage	10 VDC bi-polar (+/- 5 VDC) 16 x 350 ohm or 32 x 700 ohm load cells
Sense Amplifier	Differential amplifier with 4-wire and 6-wire sensing
Analog Signal Input Range	-45 mV to 45 mV
Analog Signal Sensitivity	0.3 μ V/graduation minimum at 7.5 Hz 1.0 μ V/graduation typical at 120 Hz 4.0 μ V/graduation typical at 960 Hz
A/D Sample Rate	7.5 Hz to 960 Hz, software selectable
Input Impedance	200 MW, typical
Noise (Usable Min LSB)	0.3 mV p-p
Internal Resolution	8 000 000 counts at 23 usable bits, approximate
Display Resolution	100 000 display divisions
Input Sensitivity	10 nV per internal count
System Linearity	\pm 0.01% of full scale
Temperature	0 to 150 nV/ $^{\circ}$ C, maximum Span \pm 3.5 ppm/ $^{\circ}$ C, maximum
Calibration Method	Software, constants stored in EEPROM
Common Mode	Voltage \pm 0.8 V in unbalanced condition
Common Mode	Rejection 120 dB min at 50 Hz or 60 Hz
Input Overload	\pm 12 V continuous, static discharge protected
EMI/RFI Protection	Signal, excitation, and sense lines protected by capacitor bypass and filtering elements

Optional Analog

Output	Fully isolated, voltage or current output Voltage output: 0–10 VDC Load resistance: 1 k Ω minimum Current output: 0–20 mA or 4–20 mA External loop resistance: 500 Ω maximum
--------	--

Digital I/O

I/O Channels	Up to 4, 5 V/TTL, active low (0 V), each software configurable as input or output
Relay Supply Voltage	5 VDC, 500 mA maximum
Input Voltage	0–5.5 V maximum
Digital Outputs	Active low, sink up to 24mA per output.
Optional	Four channel relay module, dry contact 3 A at 115 VAC, 3 A at 30 VDC 24-channel DIO board

Serial Communications

RS-232	Full Duplex
RS-485/RS-422	Half Duplex
USB	USB Type A Connector 2.0, Micro A/B Connector 2.0

Ethernet	TCP/IP
Optional	Dual channel serial board – RS-232 and RS-422/485 full and half duplex

Operator Interface

Display	LED, Six 0.56" (14 mm), 14-segment with decimal point or comma
Panel Mount Keyboard	6-key membrane panel
Universal Mount Keyboard	18-key membrane panel with a numerical keypad

Environmental

Operating Temperature	14 $^{\circ}$ F to 104 $^{\circ}$ F (-10 $^{\circ}$ C to 40 $^{\circ}$ C) (legal-for-trade applications) 14 $^{\circ}$ F to 122 $^{\circ}$ F (-10 $^{\circ}$ C to 50 $^{\circ}$ C) (industrial applications)
Storage Temperature	-25 $^{\circ}$ C to 70 $^{\circ}$ C
Humidity	0–95% relative humidity

Enclosure

Panel Mount Dimensions	6.0" x 4.0" x 4.95" (152 mm x 102 mm x 126 mm)
Weight	2.5 lb (1.2 kg)
Rating/Material	Stainless Steel 304 Type 4X, IP69K
Universal Mount Dimensions	6.7" x 8.1" x 4.3" (170 mm x 206 mm x 110 mm)
Weight	12 lb (5.4 kg)
Rating/Material	Stainless Steel 304 Type 4X, IP69K

Certifications and Approvals



NTEP

CC Number: 13-080
Class: III/IIIL 10,000d



Measurement Canada
Approval: AM-5931C



OIML

File Number: R76/2006-A-NL1-18.23
Class: III, 10,000d



Universal Model

Certification Number: UL-CA_2121087-0



Panel Mount Model

File Number: E151461



The 880 DC indicator must be connected to a class 2 power source in accordance with the NEC (National Electrical Code) and local regulations. See equipment data plate for power requirements.



© Rice Lake Weighing Systems Content subject to change without notice.

230 W. Coleman St. • Rice Lake, WI 54868 • USA USA: 800-472-6703 • International: +1-715-234-9171