

882IS Digital Weight Indicator

Fiber Optics to RS-422 Converter

The fiber optics to RS-422 converter (PN 196770) takes fiber optic light and turns it into a signal for RS-422 communications. The converter is located in an external FRP enclosure that is remotely powered and can be used in applications up to 150 ft.



Manuals are available from Rice Lake Weighing Systems at www.ricelake.com/manuals

Warranty information is available at www.ricelake.com/warranties



IMPORTANT: Use anti-static protection for grounding and to protect components from electrostatic discharge (ESD) when working inside the enclosure.



WARNING: Disconnect the enclosure from power source before opening.

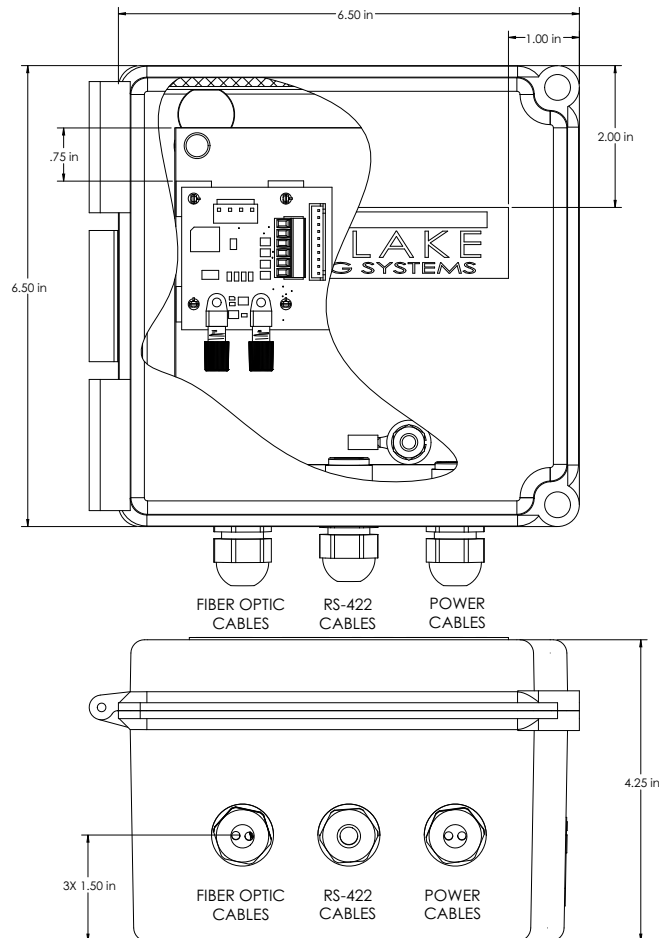

Figure 1. Fiber Optics to RS-422 Converter RFP Enclosure

Fiber Optics Assembly

The fiber optics to RS-422 converter is equipped with a duplex fiber-optic port for communicating with an 882IS or 882IS Plus located in the safe area. It provides electrical isolation and eliminates the use of I/O barriers commonly used in intrinsically safe systems. The optical fibers are plastic and the terminated ends must be properly polished prior to installation. Refer to POF Polishing Kit (PN 197384), for complete instructions on polishing the fiber-optic ends. See [Figure 1 on page 1](#) for the location of the duplex fiber-optic port in the fiber optics to RS-422 converter.



WARNING: Disconnect all power before opening the units being updated.



IMPORTANT: The fiber-optic connections between the 882IS and 882IS Plus indicator and the RS-422 converter needs to be cross-linked. The optical output of the 882IS indicator should be attached to the input of the RS-422 converter, and the indicator input to the module output.

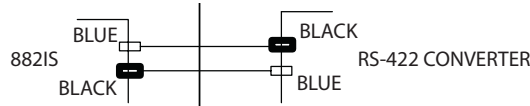

Figure 2. Fiber-Optic Cross Connection

Use the following steps for assembling the fiber-optic connectors of the fiber-optic to RS-422 converter:

1. Cut off the ends of the fiber-optic cable (150 ft length maximum), with a proper cutting tool such as a fiber-optic hot knife (PN 85548) or cutting block (PN 80892), ensuring no bends 90° or greater are in the cable.



NOTE: The cut end of the fiber-optic cable must be cut flush so that the core and outside insulation are equal. Core exposure can lead to failure.

2. Polish the fiber ends per the fiber polishing kit.
3. Insert the fiber-optic cable through the locking nut and into the connector until the core tip seats against the internal micro-lens; then back it out 1/16th in (1 mm).
4. Screw the connector locking nut down to a snug fit, locking the fiber-optic cable in place.

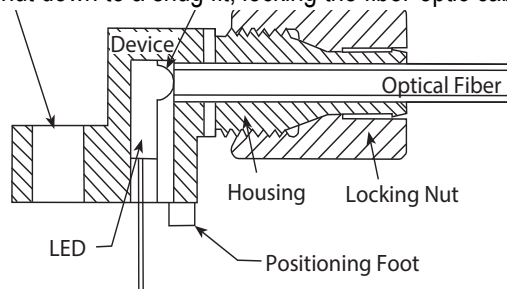

Figure 3. Fiber Optics Connector

Remote Power Source for Fiber Optics to RS-422 Converter



NOTE: If source indicator has a digital input/output, it will provide 5V which can be used to power the card.

Connector J3 provides connections for power/RS-422.

Pin	Description
1	V+ (6 V–24 V)
2	V- (GND)
3	TX_RS422-
4	TX_RS422+
5	RX_RS422-
6	RX_RS422+

Table 1. J3 Power/RS-422 Connections

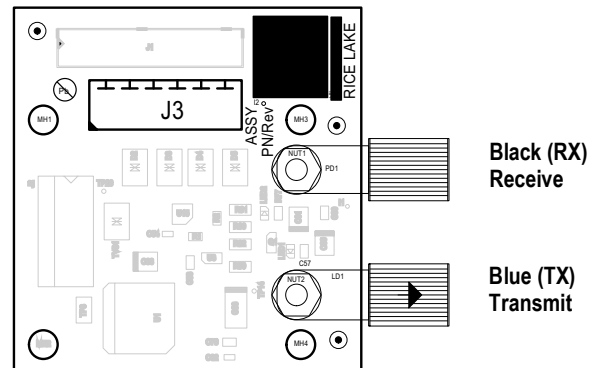

Figure 4. RS-422 Fiber Optics Board

Replacement Parts

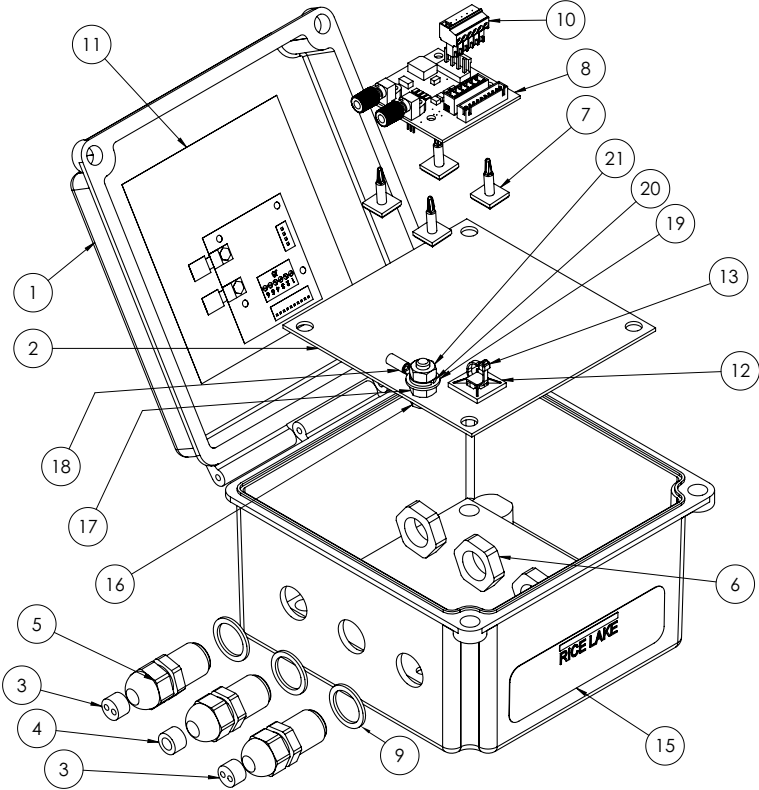

Figure 5. Replacement Parts

Item No.	Part No.	Description	Qty.
1	197028	Enclosure, Machined FRP	1
2	85308	Backplate, FRP	1
3	73997	Bushing, Multiple Cable Gland 9mm - 3/8 NPT	2
4	15664	Reducing Gland, 9mm - 3/8 NPT	1
5	15655	Cord Grip, 3/8 NPT	3
6	15656	Locknut, 3/8 NPT	3
7	31595	Support Post, PC Board 9/16 in with Adhesive Backing	4
8	180633	Fiber Optic Board, RX/TX Option	1
9	178464	Seal Ring, 3/8 NPT, Nylon	3
10	153883	Connector, 6 Position Pluggable Screw Terminal	1
11	198338	Label, Wiring, Fiber Optic to RS-422 Converter Option	1
12	15650	Mount, Cable Tie 3/4 in	3
13	15631	Cable Tie, 3 in Nylon	6
14	197846	Power Supply, 1.5 W, 12 VDC Universal Input, 100-240 VAC (not shown)	1
15	52342	Label, 4.0 x 1.25	1
16	14729	Bolt, 1/4 - 20NC x 3/4 Hex Head Bronze	1
17	14637	Nut, 1/4 - 20NC Hex Bronze Width Across Flats	1
18	33188	Connector, Ring Terminal, 1/4 in Stud Size 22-16 AWG	1
19	15149	Washer, Plain Std, 1/4 SST ID	1
20	15148	Washer, Lock 1/4 Regular Helical Spring SST ID	1
21	14642	Nut, 1/4 - 20NC Hex SST Width Across Flats	1

Table 2. Replacement Parts List



© Rice Lake Weighing Systems Content subject to change without notice.

230 W. Coleman St. • Rice Lake, WI 54868 • USA USA: 800-472-6703 • International: +1-715-234-9171