

882IS Digital Weight Indicator

mb-EPS-100-240-X2 Power Supply Instructions

The mb-EPS-100-240-X2 power supply is an FM-Entity Approved power supply for use with the 882IS digital weight indicator.



Manuals and additional resources are available from the Rice Lake Weighing Systems website at www.ricelake.com

Warranty information can be found on the website at www.ricelake.com/warranties



Do not, under any circumstances, disconnect the DC wire from the indicator while the AC power is applied to the power supply. This will cause the power supply fuse to blow.

To prevent ignition of flammable or combustible atmospheres, disconnect power before servicing.

The power supply cannot be installed in acidic atmospheres. Installation of equipment shall be in accordance with all regional, state and local electric code guidelines that apply to hazardous locations.



If modifications are made to the installation procedure, or the instrumentation is changed in any way including field repair or modification, the FM approval is void, and all warranties expressed or implied are void. The customer becomes fully responsible and liable for such modifications.



Complete all connections to the indicator before applying AC power.

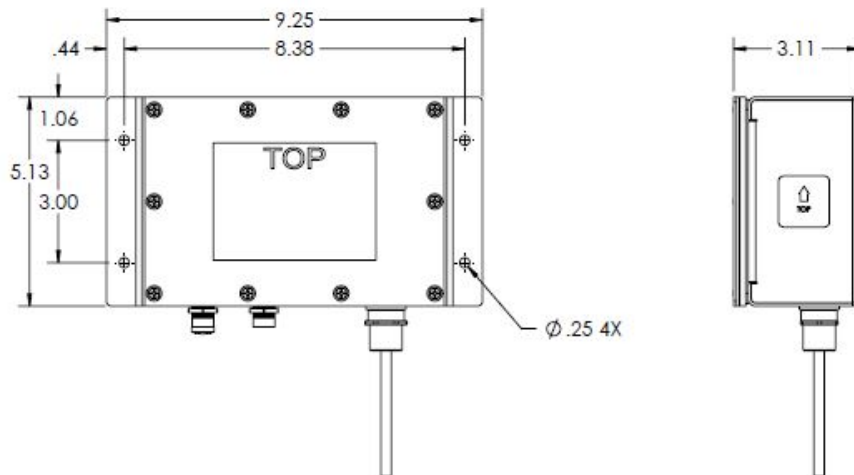

Figure 1. mb-EPS-100-240-X2 Power Supply Dimensions including Mounting Bracket (shown in inches)

Conduit System (Supplied by Customer)

AC Line Voltage Feed:

The power supply AC line voltage feed must be run through conduit and be properly sealed. The installer must comply with RLWS installation drawings (PN 182301), as well as all regional, state and local electric codes that apply to hazardous locations.

WARNING

Appropriate conduit seal is required at enclosure entrance for AC power when installed in a Division 1 Hazardous Location.

Note

The customer is responsible for the correct installation of all conduit seals in compliance with all regional, state and local electric codes that apply to hazardous locations.

Cable Connections and Installation

The following procedure is used when installing an 882IS indicator with an AC powered IS power supply.

WARNING

Do not, under any circumstances, connect or disconnect the DC wire from the indicator while the AC power is applied to the power supply. This will cause the power supply fuse to blow.

Note

Intrinsically safe cables are specified by control drawing. All cables must meet the appropriate internal inductance and capacitance according to the control drawing. Cable lengths are based on group classifications.

Before Connecting AC Power to the Power Supply

1. Determine the length of the AC power cord necessary to reach between the AC panel and the power supply mounting location.
2. Cut the AC power cord to the determined length. Remember, if mounting the IS power supply in a hazardous area, all AC power must be routed through approved conduit. Where necessary, make allowances in length for the conduit.

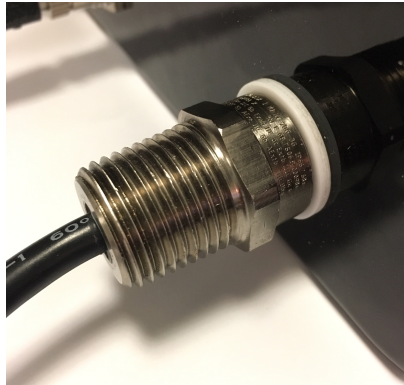

Figure 2. Metallic Adapter

3. Connect AC cord wires to AC panel per AC wiring connections.

Wire	Description
Brown	Line 1 (hot)
Blue	Neutral
Green/Yellow (from power cable)	Earth Ground

Table 1. AC Wiring

4. Install conduit seal (installer supplied) over metallic adapter shown in [Figure 2](#).

Note

Use an approved adapter to connect fitting to supplied 1/2 inch NPT fitting.

Specifications

Power

Maximum Current:	200 mA
Maximum Voltage Output:	6.8 VDC (7.5 VDC no load)
Input Range:	100-240 VAC

Environmental

Operating Temp	-10° C to 40° C (14°F to 104°F)
----------------	---------------------------------

Enclosure

Enclosure Dimensions:	9.25 in x 5.13 in x 3.11 in 177.8 mm x 130.0 mm x 79.375 mm
Weight:	6.5 lb
Material:	Mild Steel

Approvals



Class I,II,III, Division 1, Groups ABCDEFG T4 with IS outputs for

Class I,II,III, Division 1, ABCDEFG

Class I, Zone 1, AEx/Ex mb [ia Ga] IIC T4 Gb

Zone 21, AEx/Ex mb [ia Da] IIIC T135°C Db

Ta = -10°C to +40°C

ATEX/IECEX

II 2(1) G Ex mb [ia Ga] IIC T4 Gb

II 2(1) D Ex mb [ia Da] IIIC T135°C Db



IECEX



© Rice Lake Weighing Systems Specifications subject to change without notice.
Rice Lake Weighing Systems is an ISO 9001 registered company.

230 W. Coleman St. • Rice Lake, WI 54868 • USA
U.S. 800-472-6703 • Canada/Mexico 800-321-6703 • International 715-234-9171 • Europe +31 (0)26 472 1319