

920i[®] Weigh Center

Agricultural Weighing

Operation Manual



© Rice Lake Weighing Systems. All rights reserved.

Rice Lake Weighing Systems® is a registered trademark of
Rice Lake Weighing Systems.

All other brand or product names within this publication are trademarks or registered
trademarks of their respective companies.

All information contained within this publication is, to the best of our knowledge, complete and
accurate at the time of publication. Rice Lake Weighing Systems reserves the right to make
changes to the technology, features, specifications and design of the equipment without notice.

The most current version of this publication, software, firmware and all other product updates
can be found on our website:

www.ricelake.com

Revision History

This section tracks and describes manual revisions for awareness of major updates.

Revision	Date	Description
J	March 27, 2024	Established revision history; Updated replacement parts
K	May 13, 2023	Updated specifications
L	August 23, 2024	Updated replacement parts

Table i. Revision Letter History



Technical training seminars are available through Rice Lake Weighing Systems. Course descriptions and dates can be viewed at www.ricelake.com/training or obtained by calling 715-234-9171 and asking for the training department.

Contents

1.0	Introduction	5
1.1	FCC Compliance	7
1.2	Important Decals	8
1.2.1	Safety Decals	8
1.2.2	Non-Safety Decals	9
1.3	Overview	10
1.4	Front Panel	11
1.4.1	Keypad Functions	11
1.4.2	Annunciators	12
1.4.3	Softkeys	12
1.5	Indicator Settings	14
1.5.1	Date and Time	14
1.6	Mount to Animal Scale	15
2.0	Operation	17
2.1	Weighing Multiple Animals	17
2.1.1	Weigh Ticket Print-Out	18
2.1.2	Last Ticket Reprint	18
2.1.3	Summary Report Ticket	19
2.1.4	Shrink	19
2.2	Weighing a Single Animal	20
2.3	Verify Head Count	20
2.3.1	Function OFF	20
2.3.2	Function ON	20
3.0	Configuration.....	21
3.1	Database and Stored Workbooks	21
3.2	Configuration Mode	22
3.3	Zero The Inclinometer	22
3.4	USB Flash Drive	23
3.4.1	Loading Configuration Files and Databases	23
3.4.2	Loading Database Files	24
3.5	Saving Configuration Files and Databases	25
4.0	Front Panel Calibration.....	26
5.0	Appendix.....	28
5.1	Repair Parts	28
5.2	Parts Kit List	31
5.3	Weigh Center Dimensions	34
5.4	Maintenance Schedule	35
5.4.1	Checking Level Switch	35
5.5	Troubleshooting Chart	36
6.0	Specifications.....	38



Rice Lake continually offers web-based video training on a growing selection of product-related topics at no cost. Visit www.ricelake.com/webinars

1.0 Introduction

The 920i Weigh Center can be installed on most Rice Lake Weighing Systems livestock scales. This system is manufactured with top quality components and is engineered using the latest technology to provide operating features and reliability unmatched for years to come.

This manual provides operating instructions and configuration information for the 920i Weigh Center.



Manuals and additional resources are available on the Rice Lake Weighing Systems website at www.ricelake.com

Warranty information can be found on the website at www.ricelake.com/warranties

Safety Definitions:



DANGER: Indicates an imminently hazardous situation that, if not avoided, will result in death or serious injury. Includes hazards that are exposed when guards are removed.



WARNING: Indicates a potentially hazardous situation that, if not avoided could result in serious injury or death. Includes hazards that are exposed when guards are removed.



CAUTION: Indicates a potentially hazardous situation that, if not avoided, could result in minor or moderate injury.



IMPORTANT: Indicates information about procedures that, if not observed, could result in damage to equipment or corruption to and loss of data.

General Safety



Do not operate or work on this equipment unless this manual has been read and all instructions are understood. Contact any Rice Lake Weighing Systems dealer for replacement manuals.



WARNING

Failure to heed may result in serious injury or death.

Do not allow minors (children) or inexperienced persons to operate this unit.

Do not operate without all shields and guards in place.

Do not use for purposes other than weighing.

Do not place fingers into slots or possible pinch points.

Do not use any load bearing component that is worn beyond five percent of the original dimension.

Do not use this product if any of the components are cracked.

Do not exceed the rated load limit of the unit.

Do not make alterations or modifications to the unit.

Do not remove or obscure warning labels.

Keep hands, feet and loose clothing away from moving parts.

Some procedures described in this manual require work inside the indicator enclosure. These procedures are to be performed by qualified service personnel only.

Always be certain when lowering the scale that everyone is clear of the scale and any moving parts.

Use two hands when gripping the lift handle to raise or lower the scale.

Be sure the gates are latched or tied inward before transporting the scale.

Ensure all three hitch lock pins are installed and the suspension stops are in the transport position before moving the scale.



IMPORTANT

Livestock scales are not intended for the transportation of livestock or any other goods. Any addition of weight to the scale while in transport mode can cause premature component failure and voids the Rice Lake Weighing Systems warranty.

Animal Safety

Animal safety is a very serious issue and must be observed when handling any type of animal.

The scale surface may become slippery during use; a build-up of manure on the scale may reduce traction. It is recommended to take any necessary precautions to maintain an acceptable level of animal footing.

Calibration

Do not calibrate this scale with a weight cart having a gross weight in excess of 25% of the total capacity of the scale. See the scale installation manual for specific calibration instructions. This device is designed to be calibrated with single block weights spread evenly throughout the floor of the scale. If using a test cart, use 3/4" plywood for testing and calibration. This will minimize the damage to the x-lug flooring. Shift tests should not be done with more than 4,000 lb or 1,815 kg in a 4' x 4' area. Failure to comply with this warning will result in damage to the scale and void the warranty.

1.1 FCC Compliance

United States

This equipment has been tested and found to comply with the limits for a Class A digital device, pursuant to Part 15 of the FCC Rules. These limits are designed to provide reasonable protection against harmful interference when the equipment is operated in a commercial environment. This equipment generates, uses, and can radiate radio frequency energy and, if not installed and used in accordance with the instruction manual, may cause harmful interference to radio communications. Operation of this equipment in a residential area is likely to cause harmful interference in which case the user will be required to correct the interference at his own expense.

Canada

This digital apparatus does not exceed the Class A limits for radio noise emissions from digital apparatus set out in the Radio Interference Regulations of the Canadian Department of Communications.

Le présent appareil numérique n'émet pas de bruits radioélectriques dépassant les limites applicables aux appareils numériques de la Class A prescrites dans le Règlement sur le brouillage radioélectrique édicté par le ministère des Communications du Canada.

1.2 Important Decals

For safety decal information see [Section 1.2.1](#).

For non-safety decal information see [Section 1.2.2 on page 9](#).

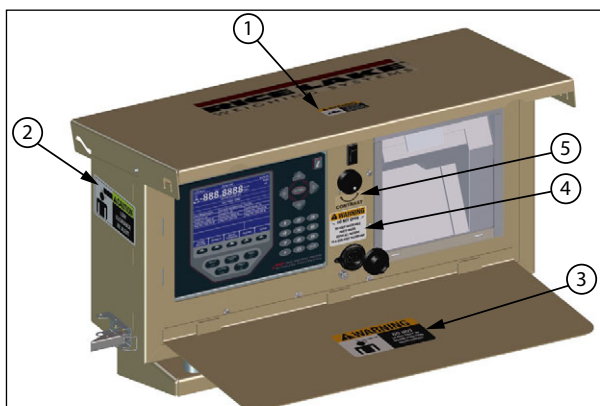

Figure 1-1. Decal Locations

Item No.	Part No.	Description	Qty.
1	151908	Read Manual	1
2	151904	Caution, Low Clearance	1
3	151907	Warning, Do Not Leave Tray Down	2
4	151906	Warning, Do Not Open	1
5	161043	Label, Contrast Control	1
-	164911	Label, 920AG Indicator	1

Table 1-1. Decals List

1.2.1 Safety Decals



Figure 1-2. Safety Decals

1.2.2 Non-Safety Decals



Figure 1-3. Contrast Control Switch Label

Operator Card – 920AG Livestock Digital Weigh Center

Refer to Operator's Manual (PN 159192) for detailed instructions.



Manuals are available from Rice Lake Weighing Systems at www.ricelake.com/manuals
Warranty information is available at www.ricelake.com/warranties

WARNING

Failure to heed may result in serious injury or death.

Do not allow minors/inexperienced people to operate.

Do not operate without all shields and guards in place.

Do not use for purposes other than weight taking.

Do not place fingers into slots or possible pinch points.

Do not use load bearing components worn beyond 5% of the original dimension.

Do not use this product if any components are cracked.

Do not exceed the rated load limit of the unit.

Do not make alterations or modifications to the unit.

Do not remove or obscure warning labels.



Figure - 1. Indicator Front Panel

Indicator Operations

Power Scale

Press the power switch to turn the indicator on or off (see Figure 1).

Enter Shrink

Shrink value is applied to the gross weight and is limited to 0.00-100.00%. Press the **Shrink %** softkey to change the shrink percentage.

Enter Head Count

1. Insert ticket into the printer. Press **FORWARD** on the printer to secure the paper.
2. Verify the scale is level. If not, a the screen displays the current pitch and roll.
3. Press **RE-ZERO** to re-zero scale if required.
4. Load animals onto scale.
5. Press the **Weigh Animals** softkey. **Enter Head Count** displays.
6. Enter the number of animals and press **ENTER**. Once the scale is stable, head count, total weight and average weight per head is displayed and a ticket begins to print and advance.
- Last weighment - information of the previous group of animals on the scale
- Current weighment - number of animals currently on the scale, their total weight and the average weight per animal
- Totals - total of all animals weighed in the current weigh batch and their average weight
7. Unload the scale.
8. Repeat steps 4-7 until all animals from the current batch have been weighed.
9. Press the **Batch Complete** softkey to complete current batch of animals. Summary information is printed on the ticket and the ticket is released.
10. Press the **Reprint** softkey any time prior to starting the next batch to reprint the last ticket.

Softkey Operations

Weigh Animals

Press to begin weighing animals. Press each time a new group of animals is placed on scale, when a batch is in process.

Shrink

Allows input of a shrinkage value when weighing animals.

Batch Complete

Press to complete batch and print summary ticket.

Reprint

Prints last stored ticket until next batch is started.

Setup

Password protected - displays current pitch and roll angles, and allows input of the following:

- Reports - Turn transaction storing and reports **On/Off**
- USB - Allows selection of USB device, downloading of database files, and adjusting of screen contrast
- Change Password - Input password protection
- Time/Date - Setting the system time and date
- More - Press to display set 2 of the softkeys
- Back - Returns to previous menu
- % Delta Wt - Percentage change in printed weight before the Live Total is updated again
- Print Report - Prints summary report of database totals
- Exit - Returns display to main screen

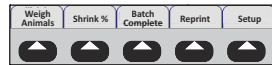

Figure - 2. Softkey Assignments

Contrast Control

Adjusts display contrast depending on ambient light and ambient temperature.



October 24, 2023

Content is subject to change without notice.
www.ricelake.com

© Rice Lake Weighing Systems
230 W. Coleman St. • Rice Lake, WI 54868
USA: 800-472-6703 • International: +1-715-234-9171

PN 164911 Rev B

Figure 1-4. 920i Ag Indicator Label

1.3 Overview

 **CAUTION:** Animal safety is a very serious issue and must be observed when handling any type of animal. The scale surface may become slippery during use; a build-up of manure on the scale may reduce traction. It is recommended to take any necessary precautions to maintain an acceptable level of animal footing.

The Weigh Center houses the 920i indicator and ticket printer. [Figure 1-5](#) shows the layout of the control box. [Figure 1-6 on page 11](#) shows a close-up of the 920i indicator. The control box is powered by a deep cycle battery located in the battery box mounted to the scale frame. This battery is normally charged during towing; however, if the battery is low, charge it using a trickle charger.



Figure 1-5. Weigh Center

 **NOTE:** The Weigh Center should be given at least 15 minutes to warm up in cold weather prior to use.

1.4 Front Panel

The keys, annunciators and knobs of the 920i Weigh Center front panel are described in the following sections.



Figure 1-6. 920i Indicator Front Panel

1.4.1 Keypad Functions

Item No.	Key/Display	Description
A	Directional Arrows	Moves the cursor to needed area and updates values
B	Enter	Saves the data entered from the keypad
C	Keypad	Allows input of numbers for head count and shrinkage
D	Clear Key	Clears the data from the display
E	Softkeys	Gives additional functionality (Figure 1-7 on page 12)
F	Zero Key	Zeros the scale
G	Gross/Net Key	Toggles between Gross and Net when tare is present
H	Tare Key	Non-functional
I	Print Key	Prints a Gross or Net Format ticket when not weighing animals
J	Units	Non-functional
K	Display Area	Displays weight and messages
M	USB Jack	Connects to flash drive or USB keyboard
N	Setup Switch	Enters into Configuration mode (must remove the screw to access)
O	Power Switch	Turns the Weigh Center on or off
P	SN Label	Contains the serial number and other important information about the scale
Q	Contrast Control Knob	Adjusts the contrast of the display

Table 1-2. Front Panel Display

1.4.2 Annunciators



Item No.	Display	Description
L		Tare Annunciator – Used to zero out a known weight
		Center of Zero Annunciator – Indicates that the scale is zeroed
		Standstill Annunciator – Indicates load force has settled in the motion window

Table 1-3. Annunciator Symbols

1.4.3 Softkeys

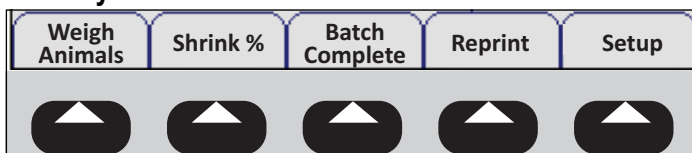

Figure 1-7. Softkey Assignments

Softkey	Description
Weigh Animals	Press when a new group of animals is placed on the scale during a batch process
Shrink %	Allows input of a shrinkage value when weighing animals
Batch Complete	Press to complete the batch and print a summary ticket
Reprint	Prints the last stored ticket, until next batch is started
Setup	Displays the current pitch and roll angles and is password protected; Allows access to the setup softkeys (Table 1-5 on page 13)

Table 1-4. Softkey Descriptions

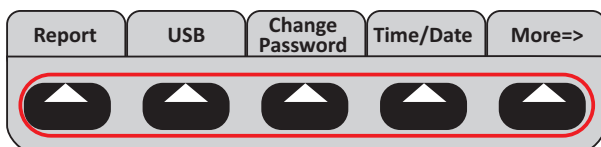

Figure 1-8. Setup Softkeys (First Screen)

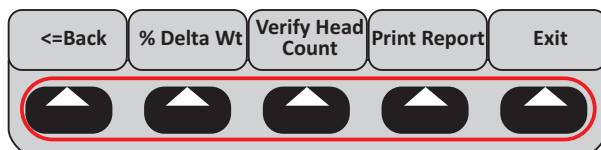

Figure 1-9. Setup Softkeys (Second Screen)

Softkey	Description
Reports	Turns transaction storing and reports ON or OFF ; If ON , the batch totals will be stored for each batch in the transaction database; If OFF , batch totals will not be stored; For more information, see Print Report below
USB	Allows selection of a USB device, download of database files and adjusting the screen contrast; See the 920i Programmable Indicator/Controller Technical Manual (PN 67887) for further information
Change Password	Allows the input of password protection; Default is none; When set to nothing no password is requested when Setup is selected
Time/Date	Sets the system time and date
More=>	Displays second softkey menu
<=Back	Returns display to previous softkey menu
% Delta Wt	Set the percent change in the printed weight before the live total starts getting updated again; <i>Example: If 1000 lb is weighed and most of those animals leave the scale and the next batch starts coming on (scale does not go all the way to zero), when it is at 100 lb (default is 90 percent change in weight) or 1100 lb (either direction) it will start updating that weight again.</i> <i>The live total should show more than the regular total if they're getting close to weighing capacity (if the scale only holds 20,000 and their last total was 19,500, they will want to only add 500 worth of animals).</i>
Verify Head Count	Turns head count verification On/Off
Print Report	A summary report can be printed by pressing the Print Report softkey, showing the totals since the last time the database was cleared (Figure 2-2 on page 19); After printing, the indicator will prompt Clear Transactions? and display YES and NO softkeys
Exit	Returns the display to the main screen

Table 1-5. Setup Soft Keys

1.5 Indicator Settings

1.5.1 Date and Time

The 920i has a built-in time and date clock that automatically adjusts for leap years. The real time clock will run even if power is removed from the indicator. There is a battery inside the indicator that will keep the clock running continuously while there is no power to the indicator.



NOTE: *There is no need to be in Calibration mode to change the time and date.*

Setting Time/Date

Use the following steps to set up the time and date.

1. Press the **Setup** softkey.
2. Press the **Time/Date** softkey.
3. Use the directional arrows to enter the current time and date.
4. Press the **Enter** key to return to the setup menu.
5. Press the **Exit** softkey to return to the main menu.



NOTE: *Press the Cancel softkey to exit without saving any changes.*

1.6 Mount to Animal Scale

Use the following steps to mount the 920i Weigh Center to the animal scale (see [Figure 1-10](#) on page 15 and [Figure 1-11](#) on page 16).

1. Use mineral spirits to clean the wall tubes where the bracket will mount, as well as the space between the holes on the mount bracket.
2. Run a bead of silicone in the area where the mounting bracket will be mounted.
3. Install the adhesive tape on the mounting bracket between the holes.
4. Place mounting bracket onto cage wall by pressing the adhesive tightly to the cage.
5. Secure with four bolts (included).
6. Mount Weigh Center onto the mounting bracket and route the cable to the battery.
7. Install the clamps to secure the conduit.
8. Secure the lower end of the conduit by drilling a hole through the cage sheeting and install the clamp with the bolt provided.

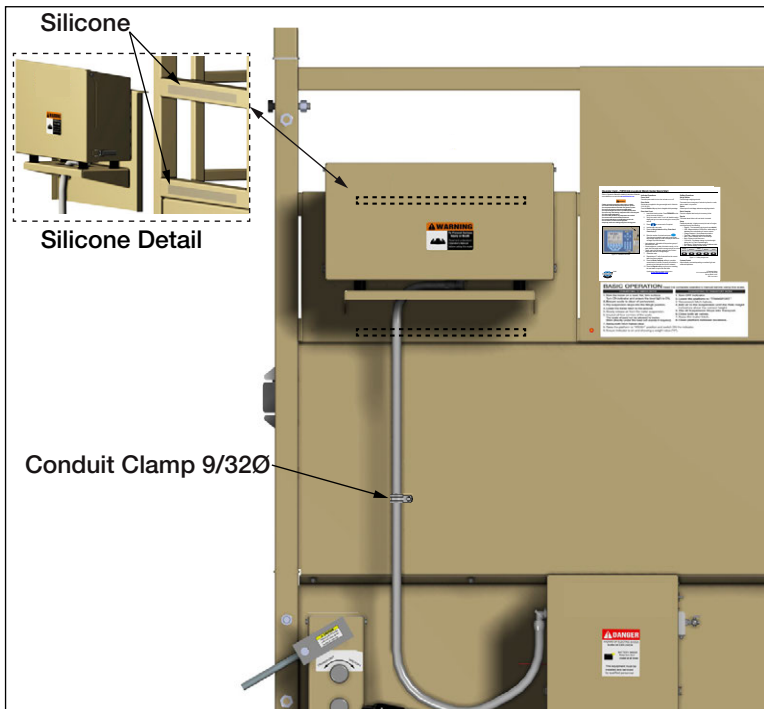

Figure 1-10. Weigh Center Mounting

Battery Box Connections

1. Connect the scale cable and secure with a cable tie.
2. Connect the power wires as shown in Figure 1-11 on page 16.
3. Replace the battery cover.

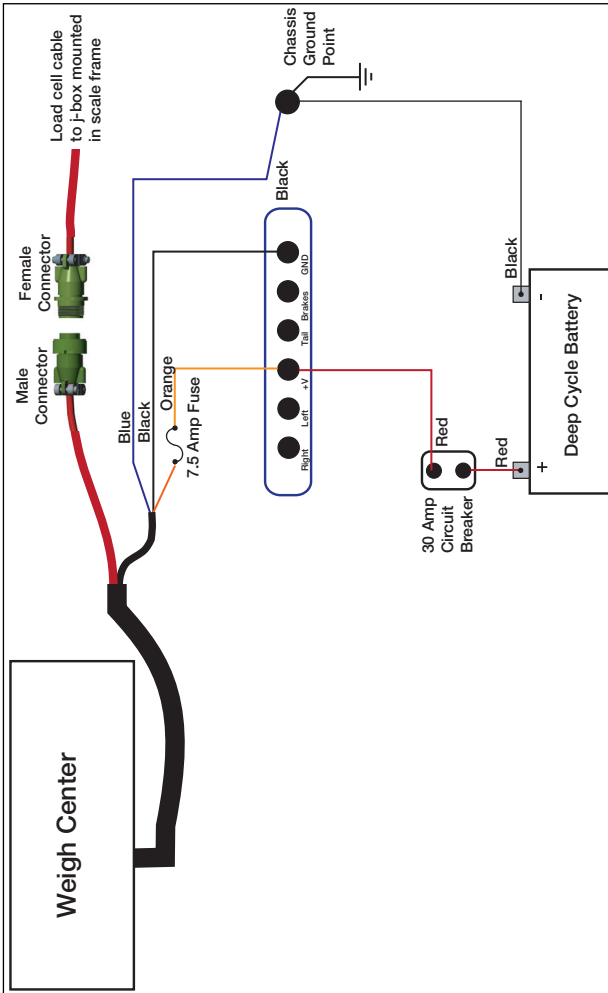

Figure 1-11. Wiring Diagram

2.0 Operation

The following sections describe the basic operation of the 920i Weigh Center.

2.1 Weighing Multiple Animals

1. Press the power switch to turn on the indicator.
2. Insert a ticket into the printer.
3. Press **FORWARD** on printer to secure the paper.





NOTE: If paper will not go into the printer under the print head, make sure the release light is on. If it is not, press **RELEASE** on the printer.

4. Verify the scale is level. If it is not, it will blank the weigh display screen and go to a screen showing the current pitch and roll.
5. Press  to re-zero the scale (if required).
6. Load the animals onto the scale.



NOTE: Animals moving around could cause scale to become out of level. An **Out of Level** prompt will display momentarily until animals settle down, if it goes off within five seconds it's ignored.

7. Press . **Enter Head Count** is displayed.
8. Use the keypad to enter the number of animals to be weighed and press . The indicator captures a stable gross weight.
9. If Verify Head Count is turned on, Re-Key in Head Count is displayed. Use the keypad to enter the number of animals to be weighed and press **ENTER**. The head count, total weight and average weight per head will be displayed.



NOTE: A line (ticket) will print out with animal count, weight, units and average weight to printer. Typically when using verify head count, the operator will remove the cattle before entering the head count the second time.

Last Weighment	Current Weighment	Totals
Head Ct: 0	Head Ct: 0	Total Head: 0
Gross Wgt: 0	Gross Wgt: 0	Total Wgt: 0
Avg. Wgt: 0	Avg. Wgt: 0	Avg. Wgt: 0

Table 2-1. Weight Display

- **Last Weighment** - Provides information on previous group of animals that were on the scale.
- **Current Weighment** - Provides information on number of animals currently on scale, total weight and the average weight per animal.
- **Totals** - Provides information on the total of all animals weighed in the current weigh batch and their average weight.

10. Unload the scale.
11. Repeat [Step 4 on page 17](#) – [Step 10](#) until all animals from the current batch have been weighed.
12. Press  to complete the current batch of animals. Summary information will be printed on the ticket and the ticket will be released.

2.1.1 Weigh Ticket Print-Out

Press **Batch Complete** to obtain the Weigh Ticket for the current batch of animals.

#Hd	Weight	UM	Avg Wt
25	7720	1b	309
22	7915	1b	360
29	8010	1b	276
76	23645	1b	311 Gross
	23645	1b	311 Net
			0.00% Shrink

Figure 2-1. Weigh Ticket Example

2.1.2 Last Ticket Reprint

Press  any time prior to starting the next batch to reprint the last weigh ticket.

2.1.3 Summary Report Ticket

Press  to generate the Summary Report Ticket.

This will printout a summary of all the batches stored in the Report memory, if the **Report** function is enabled in the Setup menu.

If enabled, this **Report** function will append and store the weigh ticket batches in the **Report** memory. Upon print-out, the operator has the opportunity to clear the report memory.



NOTE: If the reports function is enabled in the Setup menu, the summary information will also be stored to the transaction database where it can be printed or uploaded to a PC.

Summary Report		
Date/Time	#Hd	Wgt Shr
02/03/2016 10:48PM	2	550 lb 50.00%
02/03/2016 10:49PM	2	550 lb 50.00%
02/04/2016 05:52PM	76	23645 lb 0.00%

Tot Head:		80
Tot Wgt :		24745 lb Gross



Figure 2-2. Summary Report Ticket Example

2.1.4 Shrink

Press  at any time to change the shrink percentage (0.0-99.99 percent)

to be subtracted from the total gross weight. This is saved through power cycles. The default is 0.0 percent.

2.2 Weighing a Single Animal

1. Press  and enter a head count of 1.
2. Press  to print the summary information of a batch on the weigh Ticket.
3. Press  to print a complete summary report of all batches in report memory.

2.3 Verify Head Count

2.3.1 Function OFF

If the **Verify Head Count** function is **OFF** in the setup menu, the program will operate as normal. It will only prompt the operator once to enter the **Head Count** prior to printing the weighment value.

2.3.2 Function ON

If the **Verify Head Count** function is **ON** in the setup menu, the program will require extra operator verification.

It will prompt the operator to re-enter the **Head Count** value, immediately after the original **Head Count** value is entered. If the operator enters a different value, the program will store and print the latest value entered.

3.0 Configuration

3.1 Database and Stored Workbooks

Field	Type	Description
TD	Datetime	Time and date of weighment
TotalWgt	Real	Total weight on the scale
HeadCnt	Integer	Head count entered
AvgWgt	Real	Individual gross weight (total divided by head count)
Units	String	Units string (lb, kg, etc) during weighment
Shrink	Real	Shrink Factor % entered 0.0-99.99%

Table 3-1. TRANS Database Table (1000 Records)

Slot	Type
1	Single Channel A/D Card
2	Not Used

Table 3-2. Option Card Locations

Slot	Bit	Type	Function
0	1-6	Off	Not Used

Table 3-3. Digital I/O

Port	Type	Description	Setup
1	INCLIN	Inclinometer Input	19200,8,N,1
2	USB	Flash Drive/Keyboard	N/A
3	CMD	Not Used	9600,8,N,2
4	CMD	TM-U295 ticket printer	9600,8,N,2

Table 3-4. Serial Port (PN 129998) for Mobile Scale with Inclinometer

Port	Type	Description	Setup
1	CMD	Not Used	9600,8,N,2
2	USB	Flash Drive/Keyboard	N/A
3	CMD	Not Used	9600,8,N,2
4	CMD	TM-U295 ticket printer	9600,8,N,2

Table 3-5. Serial Port (PN 132302) for Static Scale without Inclinometer

3.2 Configuration Mode

Use the following steps to place the indicator into configuration mode:

1. Remove the screw on the front panel.

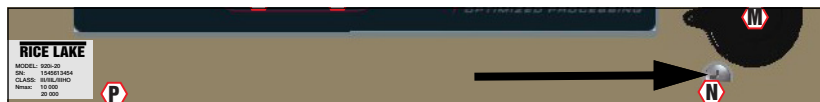

Figure 3-1. Configuration Screw Location



NOTE: Keep the screw for re-installation into the panel when configuration is complete.

2. Push a non-conductive tool into the hole until it engages the configuration switch. **CONFIG** displays.
3. Set the configuration parameters as desired.
4. Reinstall the screw, sealing according to NTEP standards.

3.3 Zero The Inclinometer

To zero the inclinometer, place the indicator into the configuration mode as follows.

Adjust the scale platform for level in both pitch and roll using a bubble or electronic level.

1. Put the indicator in configuration mode using steps 1 and 2 from [Section 3.2](#).
2. Navigate over to **Serial**, then down to **Port 1**.
3. Navigate down to **ICLIN**.
4. Navigate down to **Baud**. At this point, a **ZeroAngle** softkey will appear.
5. Press the **ZeroAngle** softkey. There will be no indication the command was accomplished — check the angle indications to verify.
6. Press the **Save & Exit** softkey to return to normal weigh mode.
7. Once in normal weigh mode, press the **Setup** softkey. The pitch and roll values will be displayed. Due to heavy filtering, it may take several seconds for the angle values to settle.

3.4 USB Flash Drive

3.4.1 Loading Configuration Files and Databases

Certain files may take extended periods of time to load directly from a PC to the 920i. A flash drive is recommended for fast loading times.

It is also recommended to create a folder matching each 920i's unit ID number, if using multiple 920i units. When loading configuration files, the unit will load the file contained in a folder matching its UID# (the default UID# is 1). If a folder matching the UID is not found, the unit will load the first file found.



IMPORTANT: If loading a configuration file from a UID subdirectory, ensure the configuration file does not change the unit ID. Otherwise, a .COD file in that subdirectory will not be recognized until the UID is manually reverted to its original number.



NOTE: File names are limited to eight characters.

1. Using a PC, copy the desired configuration file to the flash drive.
2. Insert the flash drive to the 920i Weigh Center's Type-A USB connector.
3. Press the **USB** softkey.
4. Select **Drive** and press **Enter**.
5. Place the indicator in setup mode and navigate to the SERIAL » PORT2 menu shown in [Figure 3-2 on page 23](#).

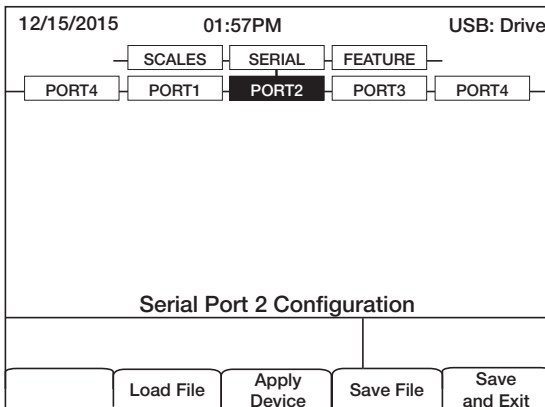

Figure 3-2. Port 2 Screen

- Press the **Load File** softkey.

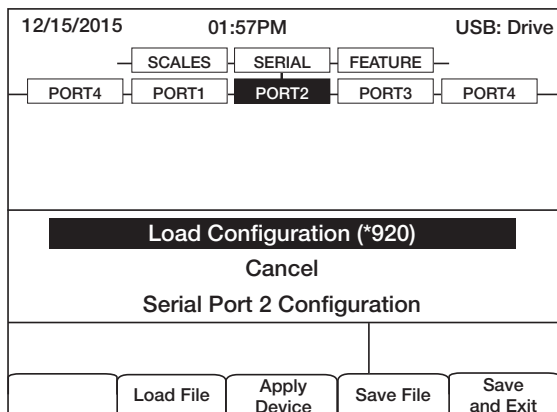

Figure 3-3. Load Configuration Selection

- Select **Load Configuration** and press **Enter**.

3.4.2 Loading Database Files



NOTE: File names are limited to eight characters. If loading a database file, be aware the indicator uses the alias name and a .db file extension when saving database files.

- Using a PC, copy the desired database file to the flash drive.
- Insert the USB flash drive into the 920i Weigh Center's Type-A USB connector.
- Press the **USB** softkey.
- Select **Drive** and press **Enter**.

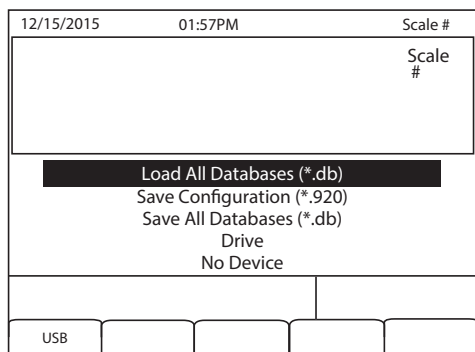

Figure 3-4. Load All Databases Selection

- Select **Load All Databases (*.db)** and press **Enter**.

3.5 Saving Configuration Files and Databases

Certain files may take extended periods of time to save directly from a PC to the 920i. For fastest save times, using a flash drive is recommended.



IMPORTANT: When saving a configuration file, the indicator will attempt to save to a folder matching its UID number (the default UID# is 1). If a folder is not found, the file will be saved to the drive's root directory and overwrite any existing files matching its UID# followed by the .920 file extension i.e., 1.920i.



NOTE: When 920i saves a database, it uses the alias name and a .db file extension.

1. Insert the flash drive into the 920i Weigh Center's Type-A USB port.
2. With the indicator in weigh mode, press the **USB** softkey.



NOTE: If the **USB** softkey is not displayed, see the *920i Programmable HMI Indicator/ Controller Installation Manual*(PN 67887).

3. Select **Save Configuration or Save All Databases (*.db)** and press **Enter**.

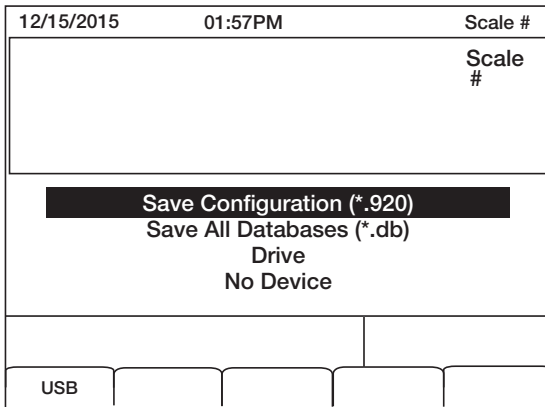

Figure 3-5. Save Configuration Menu

4.0 Front Panel Calibration

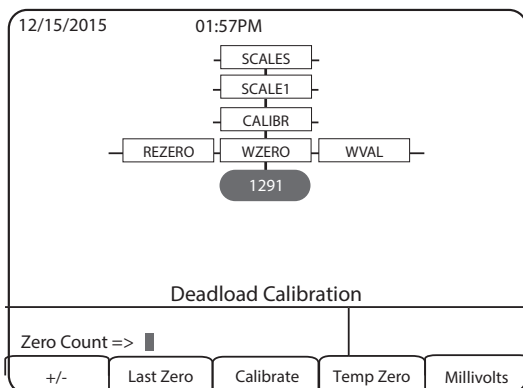

Figure 4-1. WZERO Calibration Display

The **CALIBR** sub-menu (under the **SCALES** menu, see Figure 4-1) is used to calibrate the 920i Weigh Center. The zero, span and linear calibration point displays provide a set of softkeys used specifically for calibration procedures.

Sub-menu Softkeys	Description
+/-	Toggle this key to allow entry of negative or positive values
Last Zero	Recalls the last established zero value to allow calibration without removing test weights or product from scale
Calibrate	Performs a calibration for the selected point
Temp Zero	Temporarily zeroes the displayed weight of a non-empty scale; After a span calibration, the difference between the temp zero and the previously calibrated zero value is used as an offset
Millivolts (or Counts)	Toggles between the display of captured A/D counts and captured millivolts values and allows entry of calibration values in mV or counts

Table 4-1. Calibration Submenu

Use the following steps to calibrate the 920i using the front panel.

1. Place the indicator in setup mode. The display reads **Scale Configuration**.
2. Remove all weight from the scale.
3. With the **SCALES** menu highlighted, press the **Down** key.
4. Select the scale to be calibrated.
5. Press **Down** again in order to highlight the **GRADS** parameter.
6. Press **Left** to highlight the **CALIBR** submenu.
7. Press **Down** to go to zero calibration (**WZERO**).

8. Ensure scale is empty, then press **down** again to show the current **WZERO** value.
9. Press the **Calibrate** softkey to calibrate zero. When complete, the new A/D count for the zero calibration is displayed.
10. Press **Enter** to save the zero calibration value and go to the next prompt (**WVAL**).
11. With **WVAL** displayed, press **Down** to show the stored calibration weight value.
12. Use the numeric keypad to enter the actual value of the calibration test weights.
13. Press **Enter** to save the value and go to span calibration (**WSPAN**).
14. Place test weights on the scale.
15. Press **Down** again to show the current **WSPAN** value.
16. Press the **Calibrate** softkey to calibrate span. When complete, the new A/D count for the span calibration is displayed.
17. Press **Enter** again to save the span calibration value and go to the next prompt (**WLIN**).
18. Press **Up** to return to the **SCALES** menu, or press the **Save and Exit** softkey to exit **Setup** mode.

5.0 Appendix

5.1 Repair Parts

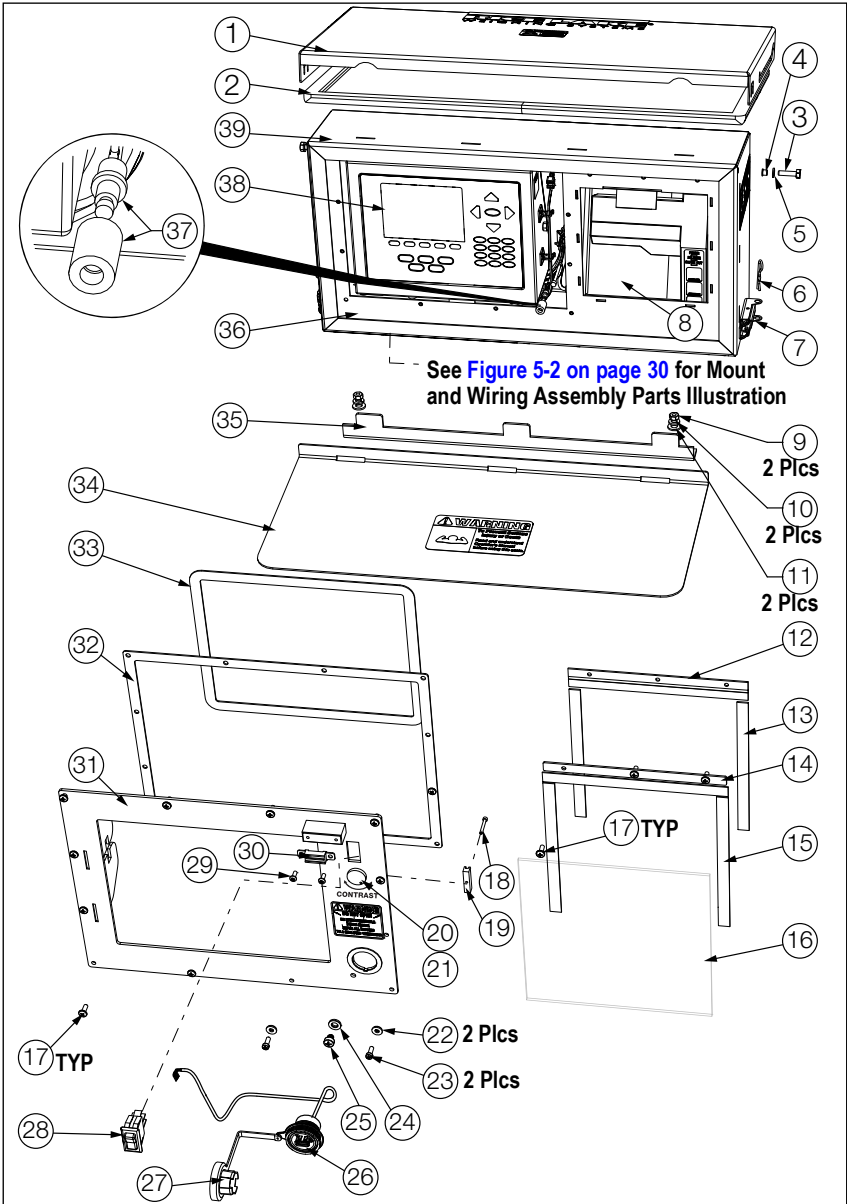

Figure 5-1. 920i Weigh Center Parts Illustration

Item No.	Part No.	Description
1	131457	Door, Enclosure
2	131443	Gasket, Cover
3	128753	Screw, Cap 1/4-20 x 1 Hex
4	155609	Washer, Nylon
5	155608	Shoulder Washer, SST
6	160302	Hairpin, 0.08 x 1 9/16
7	171522	Latch, Toggle
8	65635	Printer, Epson TMU-295
	71630	Ticket, Print 4-1/4 x 7"
	22263	4 1/4 x 5 1/2 Printer Blank Tickets, 3 Part Carbon-less, sold per each
	29583	Printer Ribbon Black
9	126993	Nut, Hex 5/16-18 Grade 5
10	15153	Washer, Lock 5/16 Regular
11	111843	Washer, Plain 5/16 Type A
12	127288	Hinge, Plastic Continuous
13	127108	Magnet, 1/2" x 0.06 Thick
14	131439	Foam, 1/2" Adhesive
15	127072	Foam, 1/2" Adhesive
16	131441	Printer Splash Shield
17	126938	Screw, Machine 8-32 x 7/16"
18	131459	Screw, Cap 4-40 x 7/8 SHCS
19	131461	Mount Clamp
20	160425	Contrast Control Knob
21	161614	Cable, Contrast Control
22	45042	Washer, Bonded Sealing SST
23	30623	Screw, Mach 8-32 NC x 7/16"
24	44676	Washer, Bonded Sealing
25	42640	Screw, Mach 1/4-28 NF x 1/4"
26	131675	Connector, USB-A Front PNL
27	118994	Connector, Bulgin Sealing
28	128774	Switch, Rocker
29	14844	Screw, Mach 6-32 NC x 3/8"
30	131698	Catch, Magnetic Cabinet
31	131451	Front Bezel, Indicator
32	131448	Gasket, Bezel/Front Plate
33	131447	Gasket, Indicator/Front
34	131455	Printer Shelf
35	131446	Mount, Shelf
36	131486	Front Plate, Weigh Center
37	131667	Switch Assy, Single Pole
38	131662	Indicator, 920i Plus, Universal
	66502	Overlay, Membrane Switch
39	131456	Enclosure, Weigh Center

Table 5-1. 920i Weigh Center Parts

See [Figure 5-1](#) on page 28 for
Weigh Center Parts Illustration

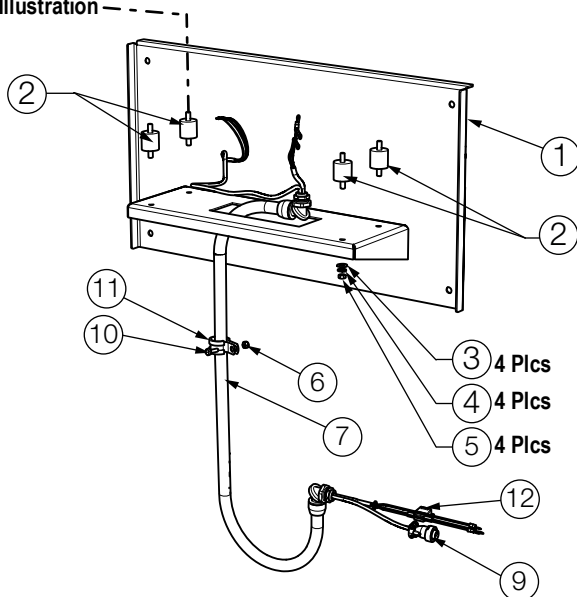

Figure 5-2. Weigh Center Mounting and Wiring Assembly Parts Illustration

Item No.	Part No.	Description
1	131532	Weigh Center Platform
2	131458	Anti-Vibration Mount
3	111843	Washer, Plain 5/16 Type A
4	15153	Washer, Lock 5/16 Regular
5	126993	Nut, Hex 5/16-18 Grade 5
6	14635	Nut, Lock 1/4-20NC Hex
7	131671	Cable Assy, MAS Control
9	127259	Conn, MS Male, Complete Kit
	127260	Conn, MS Female
	131454	Shoulder Washer, Nylon
10	127008	Screw, Cap 1/4-20 x 3/4
11	127386	Clamp, 3/4 ID x 5/8 Wide
12	126870	Fuse, Blade 7.5A 32V ATO

Table 5-2. Weigh Center Mounting and Wiring Assembly Parts

5.2 Parts Kit List

Part No.	Description
14626	Nut, Kep 8-32NC Hex
14862	Screw, MACH 8-32 NC x 3/8
15133	Washer, Lock NO 8 Type A
15631	Cable Tie, 3" Nylon
15665	Gland, Reducing 1/2 NPT
15887	Terminal Block, 6 Position
19538	Post, Slotted Black Seal
30623	Screw, MACH 8-32 NC x 7/16
53075	Clamp, Ground Cable Shield
70599	CONN, 6 Pos Screw Terminal
71126	CONN, 4 Pos Screw Terminal
75062	Washer, Bonded Sealing SST
77180	CONN, 8 Pos Screw Terminal
94422	Label, Capacity 0.40 x 5.00
132285	Screw, Cap 3/8 - 16 NC x 3 1/4 Hex
22072	Nut, Lock 3/8-16 NC Hex

Table 5-3. Parts Kit

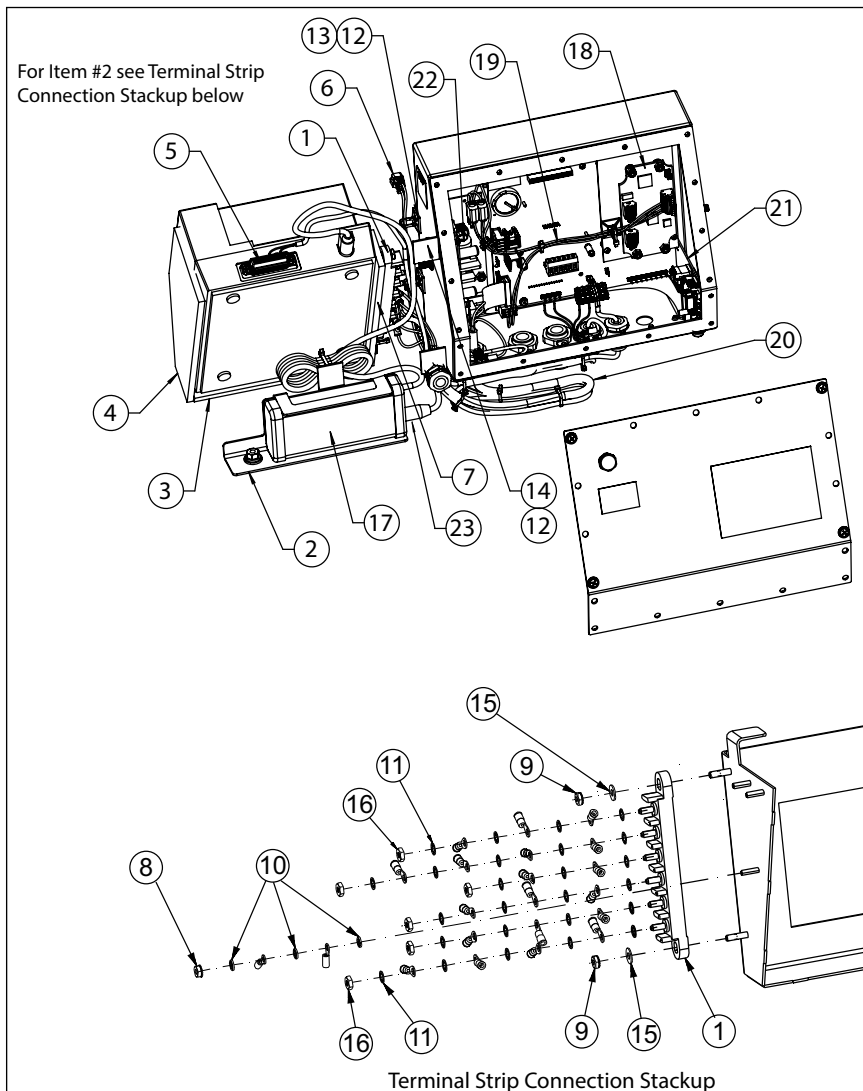

Figure 5-3. 920i Weigh Center Parts Illustration – Internal Components



NOTE: Enclosure has been removed for clarity.

Item No.	Part No.	Description
1	127402	Terminal Block, 6 Steel
2	150681	Clamp, Power Supply
3	131439	Foam Insert, Front
4	131440	Foam Insert, Side
5	131668	Cable Assy, Printer
6	131673	Cable Assembly, Power
7	131758	Foam Insert, LH Side
8	14626	Nut, Kep 8-32 NC HEX
9	14632	Nut, Kep 10-32 NF HEX
10	15134	Washer, Lock NO 8 Type A
11	15140	Washer, Lock NO 10 Type A
12	15631	Cable Tie, 3" Nylon
13	15650	Mount, Cable Tie 3/4"
14	15658	Mount, Cable Tie 1"
15	22062	Washer, Plain NO 10 Type A
16	22065	Nut, Mach Screw 10-24 NC
17	72309	Power Supply, Star 12 VDC
18	131660	Board, Inclinometer
19	131663	Wiring Harness, Power
20	131666	Cable, Power
21	111109	Board Assembly, 920i Plus USB
22	132791	Power Supply, DC\DC +/- 6V
23	126870	Fuse, Blade 7.5 A 32 V ATO
	167151	Cable, In-line Fuse Holder
-	68532	Card A/D Single Channel
-	164375	Display Board
-	109549	CPU Board, 920i Plus

Table 5-4. 920i Weigh Center Parts List – Internal Components

5.3 Weigh Center Dimensions

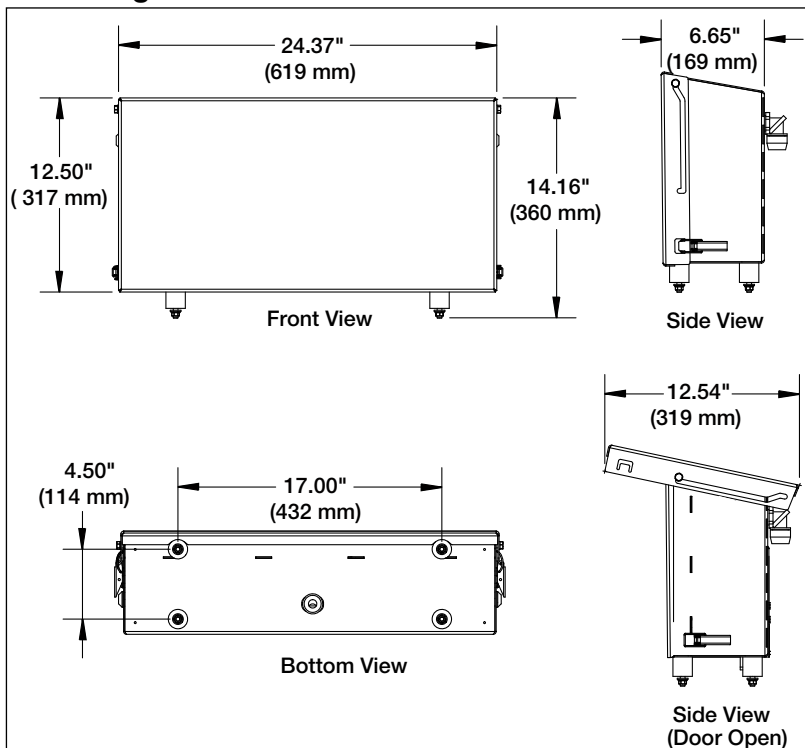

Figure 5-4. Weigh Center Dimensions

5.4 Maintenance Schedule

Weekly

Check all external cables and conduit for damage.

Yearly

Check indicator level switch.

5.4.1 Checking Level Switch

During normal operation of the level sensing device, the operator will not see any messages from the system. The software has been designed so only errors will be reported to the operator.

If the scale is out of level during setup, the **Out Of Level** message will be displayed.

If during operation the scale should shift and become out of level, the same message will be displayed and the operator will not be able to weigh animals while the out of level condition exists.



NOTE: *Should the level sensor become faulty, the Out Of Level message will be displayed and the pitch and roll angle may display No Sensor Comm. Replacement of the level sensor or CPU board in the indicator may be required.*

1. Place the system on a slope greater than four degrees (example – a steep approach).
2. Alternately, jack up one side of the base frame so that the scale is off level by more than four degrees.
3. Turn on the indicator and check the display.

If the indicator does not display **Off Level**, there may be a faulty PCB. Consult the local scale dealer.

This test should be performed in all four directions: front low, rear low, right side low and left side low.

5.5 Troubleshooting Chart

Symptom	Probable Cause	Action
Indicator will not power up	Blown in-line fuse	Replace the in-line fuse, Rice Lake Weighing Systems (PN 126870); The fuse holder is located near the battery of the indicator
	Voltage is less than 11 V	Repair faulty electrical system; RLWS panel requires at least 11 V to operate properly
Indicator turns off or resets in the middle of a transaction	Low voltage to control panel	Check other electrical equipment that may be operating; Check for corrosion or damaged wiring; Measure voltage
Level will not zero	The trailer is more than four degrees off level	Return the scale to a level position
	Faulty inclinometer	See Section 3.3 on page 22 ; Contact your local Rice Lake Weighing Systems dealer
System will not weigh animal or batch complete	The weight reading is not stable enough	It may be too windy to get a stable weight, check the standstill icon on the display area on the indicator; The system can only start when the standstill icon is displayed
Weight reading on the indicator is unstable	The circuit board in the control panel may be wet or the junction box for the load cells may have moisture	Dry areas contaminated with moisture; Check for leaks and reseal
	A load cell cable may be pinched or damaged	Contact Rice Lake Weighing Systems or a qualified dealer for support; Cutting the load cell cable will void the warranty; Special repair techniques are required
Scale has a positive error when loading or a negative error when unloading	Mechanical binding problem on the scale	Check for debris around or under the scale; Check each load cell location for foreign material; Check all items that run from on the scale to off the scale; Check gates or gathering panels for contact
Scale has a negative error when loading or a positive error when unloading	Moisture is present in the electrical system	Dry any areas that are contaminated with moisture; Check for leaks and reseal

Table 5-5. Troubleshooting

Symptom	Probable Cause	Action
Printer will not function and/or will not print anything	Is the release light on the printer flashing?; May indicate a low voltage to the printer	The Rice Lake Weighing Systems unit requires at least 11 V to operate properly; Is the truck running?; The truck may need to be running to supply enough power or the truck may have a faulty electrical system
	Print head may be jammed with paper	Remove the print head cover and ribbon; Check for bits of paper stuck in the paper feed mechanism
	Print head may be packed with dirt from operating in dusty conditions	Remove the print head cover and ribbon. Blow out with air; If the printer is very dirty it may require service by a qualified technician
	Blown fuse in wire assembly	Replace fuse, Rice Lake Weighing Systems PN 167151
Printer is printing unrecognizable characters	The power supply is excessively noisy	Contact Rice Lake Weighing Systems; An in-line power filter may be necessary
	Incorrect dip switch settings	Settings are 1,7,8 ON rest OFF
Printing on the ticket is faint or hard to read	The printer's ink ribbon may need to be replaced	Replace the ribbon cartridge (PN 29583)
	The printer head may be damaged	Requires service by a qualified technician
Dashes in weight display	Over-range or under-range scale condition	Check the scale; For out-of-range conditions in total scale display, check all scale inputs for positive weight values
Blue Screen	Possible corrupt core software	Reset or reload software
	–	Check LCD contrast control in Weigh Center
Hangs in 888 display	Corrupt core software	Reset or reload software
A critical configuration error has been detected	Bad battery	Press Enter to retrieve the last Save or Exit contents
Scale will not ZERO	Weight on scale larger than the allowable ZERO window	Clean scale deck of debris then Zero scale
	–	Zero Window parameter set incorrectly

Table 5-5. Troubleshooting (Continued)

6.0 Specifications

Power:

AC voltages: 115 VAC
Frequency: 50 or 60 Hz
DC Voltages: 12 VDC

Power Consumption:

340 mA, maximum at 115 VAC (26 W)

Excitation Voltage:

10 \pm VDC, 16 x 350 ohm or 32 x 700 ohm load cells per A/D card

Analog Signal Input Range:

-10 mV to +45 mV

Analog Signal Sensitivity:

0.3 μ V/graduation minimum at 7.5 Hz
1.0 μ V/graduation typical at 120 Hz
4.0 μ V/graduation typical at 960 Hz

A/D Sample Rate:

7.5 to 960 Hz, software selectable

Resolution:

Internal resolution: 8,000,000 counts
Weight display resolution: 9,999,999

System Linearity:

\pm 0.01% full scale

Communication Ports:

Four ports on CPU board support up to 115,200 bps
Port 1: Full duplex RS-232
Port 2: USB Type A and Type B connectors
Port 3: Full duplex RS-232, 20 mA output
Port 4: Full duplex RS-232, 2-wire RS-485, 20 mA output

Display:

(L x H) 4.6 x 3.4 in (116 x 86 mm)
320 x 240 pixel VGA Liquid Crystal Display (LCD) module with adjustable contrast
Transflective display - standard

Keyboard:

27-key membrane panel, tactile feel

Temperature Range:

Certified: 14°F to 104°F (-10°C to 40°C)

Operating: 14°F to 122°F (-10°C to 50°C)

Warranty:

Two-year limited

Approvals:



NTEP

CC Number: 01-088

Class III/IIIL 10,000d

Measurement
Canada
Approved

Measurement Canada

AM-5426

Class III/III HD 10,000d





© Rice Lake Weighing Systems Content subject to change without notice.

230 W. Coleman St. • Rice Lake, WI 54868 • USA USA: 800-472-6703 • International: +1-715-234-9171