

EL232 XPCD

Explosion Proof Remote Display

Installation Manual



About This Manual	1
1.0 Introduction.....	5
1.1 System Limitations and Restrictions	5
1.2 Front Panel Annunciators	6
2.0 Installation and Wiring	7
2.1 EL232 XPCD Enclosure	7
2.1.1 Mounting and Mounting Locations	7
2.2 Sealoff Fittings	8
2.3 Cabling and Conduit Runs	9
2.3.1 Cabling	9
2.3.2 Conduit Runs	10
2.4 AC Power Wiring	11
3.0 Indicator Setup.....	12
3.1 Serial Data Inputs	12
3.1.1 Condec Data Format	13
3.1.2 ElectroScale Data Format	13
3.1.3 Analogic Data Format	14
3.1.4 Cardinal Data Format	14
3.2 Serial Data Input	14
3.2.1 RS232 C	14
3.2.2 20 mA Active Current Loop Input	15
3.2.3 20 mA Passive Current Loop Input	16
3.3 Configuration of the EL232 XPCD	17
3.3.1 Loss of Signal Display	18
3.4 Serial Data Output	18
4.0 EL232 XPCD Operation	19
4.1 Lamp Test	19
4.2 Software Revision	19
4.3 Current Baud Rate Setting	19
4.4 Input Signal Type	19
4.5 Indicator Type	19
4.6 Receiving Data for the First Time	20
5.0 Appendix	21
5.1 Troubleshooting	21
5.2 Recommended Spare Parts	21
5.3 Specifications	22
EL232 XPCD Limited Warranty.....	23

About This Manual

The EL232 XPCD explosion proof remote display represents the latest in state-of-the-art microprocessor technology specifically applied to the explosion proof weighing marketplace. This EL232 has been modified for use in a hazardous electrical environment.

This manual provides information on installation of the EL232 XPCD. The installer should be familiar with the National Electrical Code and RP 12.6 (*Recommended Practice*) requirements for installation of equipment in hazardous areas (NEC Article 504, *Intrinsically Safe Systems*) published through the Instrument Society of America.



Warning

This equipment is intended only for industrial applications.

This instrument and accompanying equipment must be installed and serviced by an authorized technician in accordance with the instructions provided in this manual. Improper specification, installation, or service of this equipment could result in personal injury or property damage.

Read all of the manual prior to installation. Do not assume that all hazardous area installations are identical. Do not begin installation until all safety procedures are in place including lockouts, additional ventilation, or washdowns. Make sure plant safety personnel have checked the area in which you will be working and have officially declared it safe for work to proceed.

All explosion proof enclosures must remain closed unless being serviced by qualified personnel in an area which safety inspectors have tested and declared safe. All other openings have sealoff fittings or plugs provided. Each opening must have a sealoff fitting or plug correctly installed in it. Sealoff installation is critical. Maximum voltage inside of enclosure must not exceed 250VAC.

The illustrations shown on the following pages represent a basic explosion proof flame control theory (XPCD).

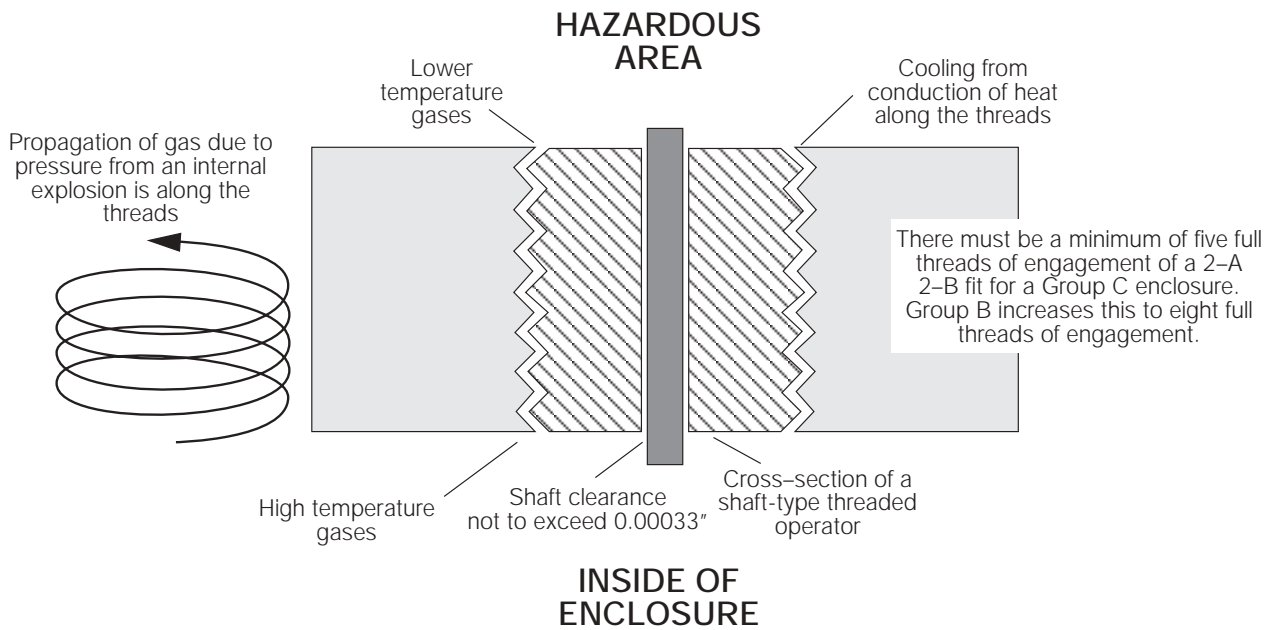
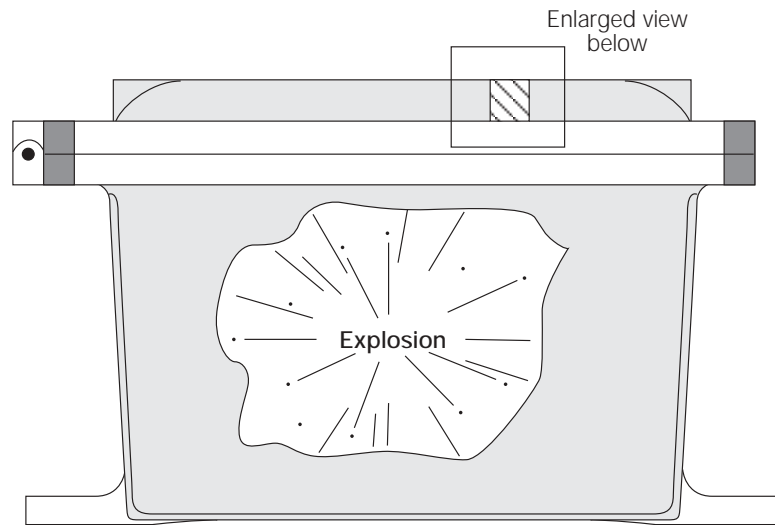

The push buttons, rotary switches and sealing fittings are all attached to the enclosure via drilled and tapped holes in the enclosure. Just as with the flange, all threaded operators and fittings carefully control the flame path.

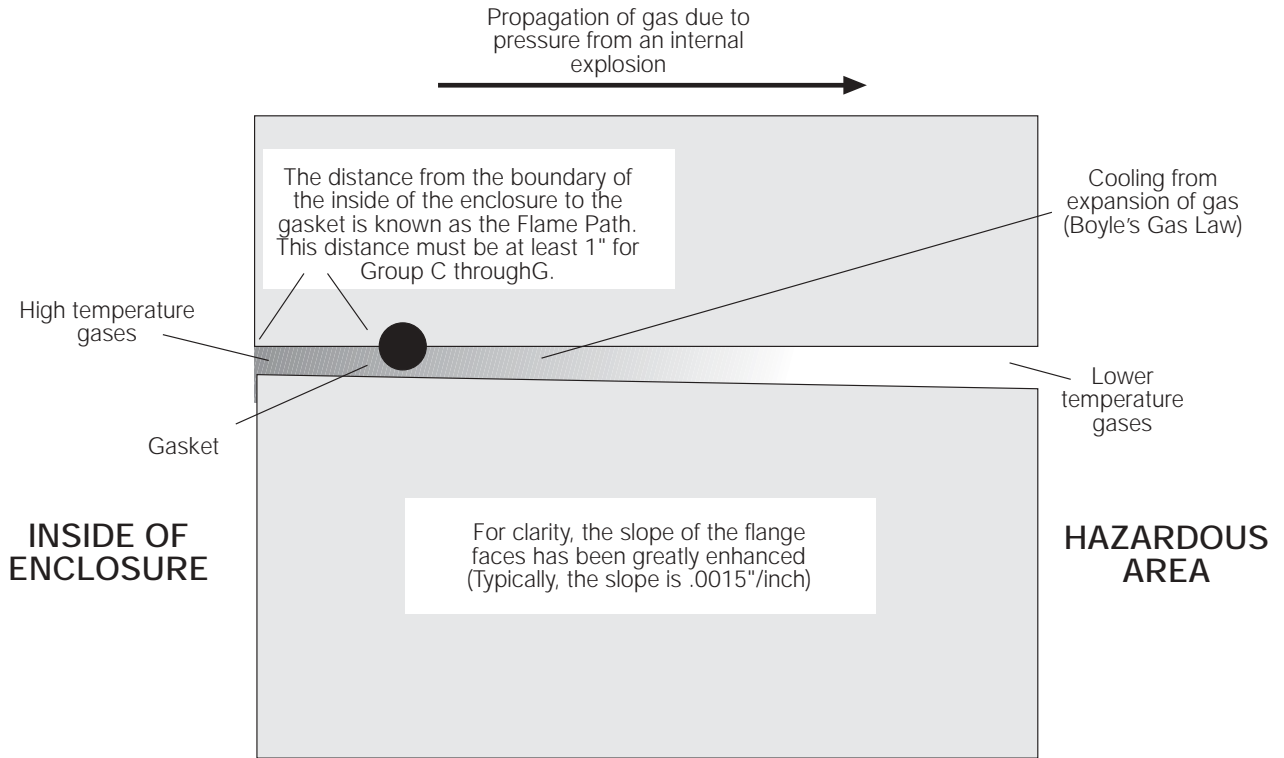
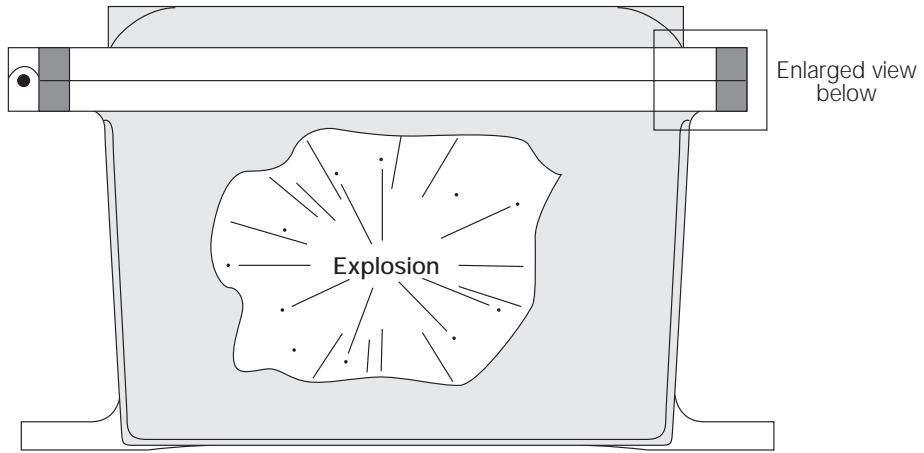

The design intent of an explosion proof enclosure is not to contain an explosion, but to control it. The flame path is carefully controlled at the flanges. This insures that if an explosion occurs, any gases that escape will be cooled to a temperature below the ignition point of any atmosphere specified within that enclosure's rating.

1.0 Introduction

The EL232 XPCD is a high performance serial remote data display. It receives serial ASCII data (20 mA current loop or RS-232), and displays weight data on a 8" LED display. Five LED status indicators are provided for Lbs, Kg, Gross, Net, and no signal. (see Figure 1-1 on page 6).

The EL232 XPCD supports twelve scale formats which include:

- UMC Series
- General Freedom I and II
- Electroscale 560
- A & D Instruments 4322, 4323, 4316
- Weightronix WI-110 and WI-120
- Toledo indicators with "High speed data format"
- Flex-weigh DWM-4
- Analogic AN5315, AN5316, AN5322
- Masstron M-2500 and M-5000
- Fairbanks 90-164 series
- Streeter Richardson 9000
- Cardinal 738
- Instruments with programmable ASCII output
- Generic smart receiver mode

1.1 System Limitations and Restrictions

The following items represent limitations and restrictions on the use of the EL232 XPCD:

- All wiring, connections, conduit and grounds must comply with the National Electrical Code.
- No modifications can be made in the field.
- It is mandatory to return the EL232 XPCD to Rice Lake Weighing Systems for service.

1.2 Front Panel Annunciators

Figure 1-1 illustrates the EL232 XPCD front panel which include six LED display digits and five LED annunciators.

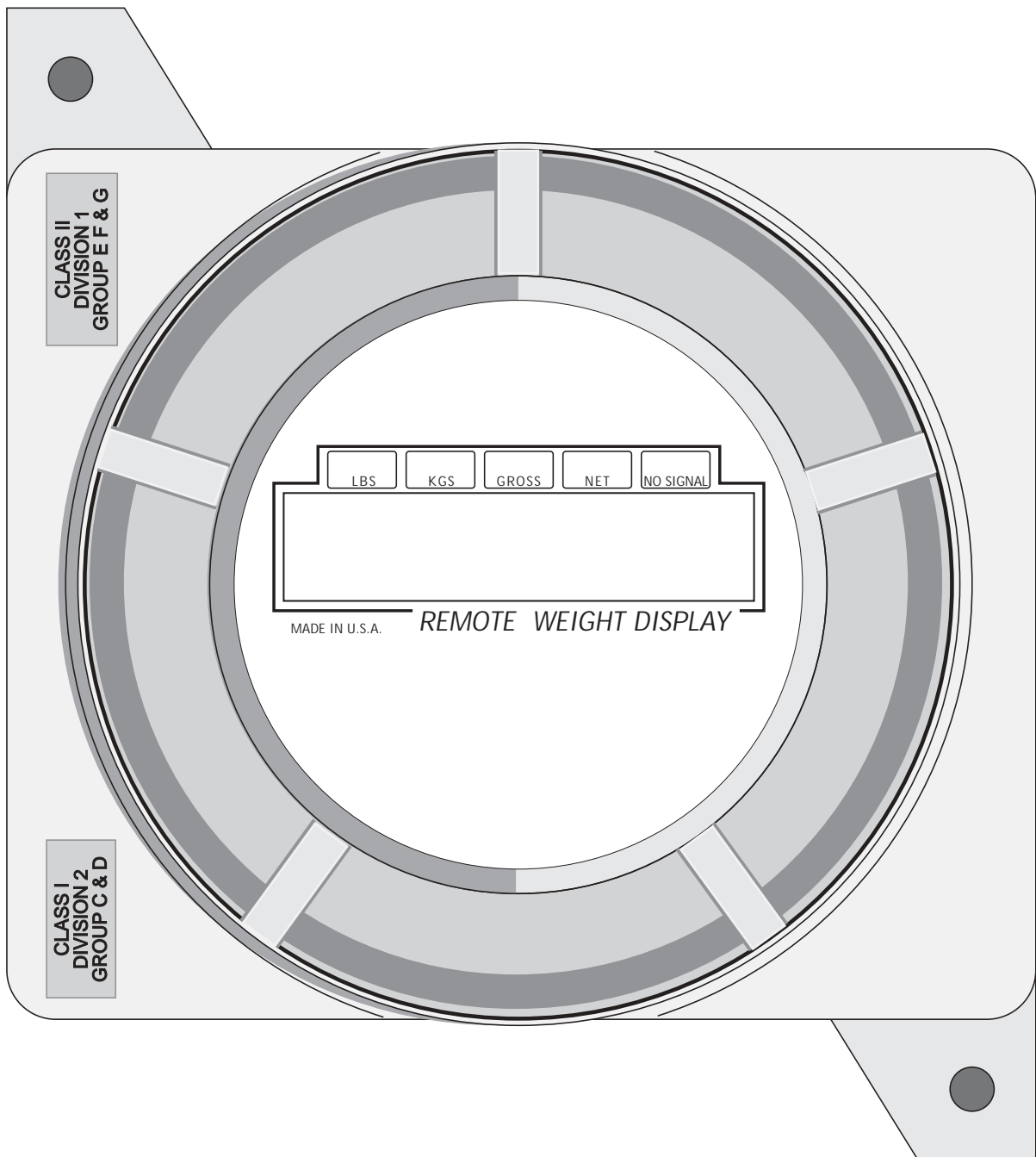

Figure 1-1. EL232 XPCD Front Panel

2.0 Installation and Wiring

This section is provided to help the installer and describes the procedures for installing the EL232 XPCD remote display and enclosure, AC wiring, conduit runs, and internal modifications for the EL232 XPCD.

2.1 EL232 XPCD Enclosure

The following sections describe mounting locations and how to mount the enclosure and sealoff the fittings.

2.1.1 Mounting and Mounting Locations

The mounting and installation of an explosion proof enclosure is more involved than a general purpose unit and it is recommended that all outdoor installations have a shelter, roof, enclosure, or covering. The EL232 XPCD enclosure is cast aluminum and direct sunlight can cause it to heat to a very high temperature which can damage the electronics inside. (Such damage is not covered by the warranty). Sheltering the unit from sunlight will help control the internal temperature. In cold climates, it is recommended an indicator heater be installed (optional). These are small and easily installed on the backplate.

Sunlight and variable temperatures can also cause moisture to condensate inside the enclosure. It is recommended to shelter the outdoor installation by a shelter, roof, enclosure, or covering. Moist environments can also be controlled by the use of desiccants. Contact your local dealer for information on desiccants.



Caution *Do not place desiccants on top of circuit boards. Place them in the bottom of the enclosure away from electronics and wires.*

The explosion proof enclosure is substantially heavier than a standard enclosure and thus the mounting surface must be capable of reliably supporting the added weight.

The mounting and installation of the EL232 XPCD must be into Division II or safe electrical area per NEC, Section 500. The inside of an explosion proof enclosure is classified as a Division II environment.

Glass Face

The glass face on the EL232 XPCD may look indestructible but it is not. If damaged in any way, the entire unit must be completely turned off at the source until it is replaced. The enclosure must be protected from blows and scrapes from passing equipment, falling objects, thick glues or resins, certain acids which eat aluminum, and other hazards which can break or damage the enclosure.

The glass window in the enclosure must be not become scratched, pitted, or damaged in any way. Do not wipe the glass with dirty gloves or rags as this can cause the glass to become scratched.

2.2 Sealoff Fittings

The utmost care must be taken to completely seal the inside of the remote display off from the outside world. To do this all wiring into and out of the enclosure must be in conduit using sealoff fittings between the remote display and the conduit. The sealoff fittings ensure that the hazardous atmosphere does not travel either through the conduit or through insulation or wiring back to the safe area. The graphic shown below illustrates the location of sealoff fittings.

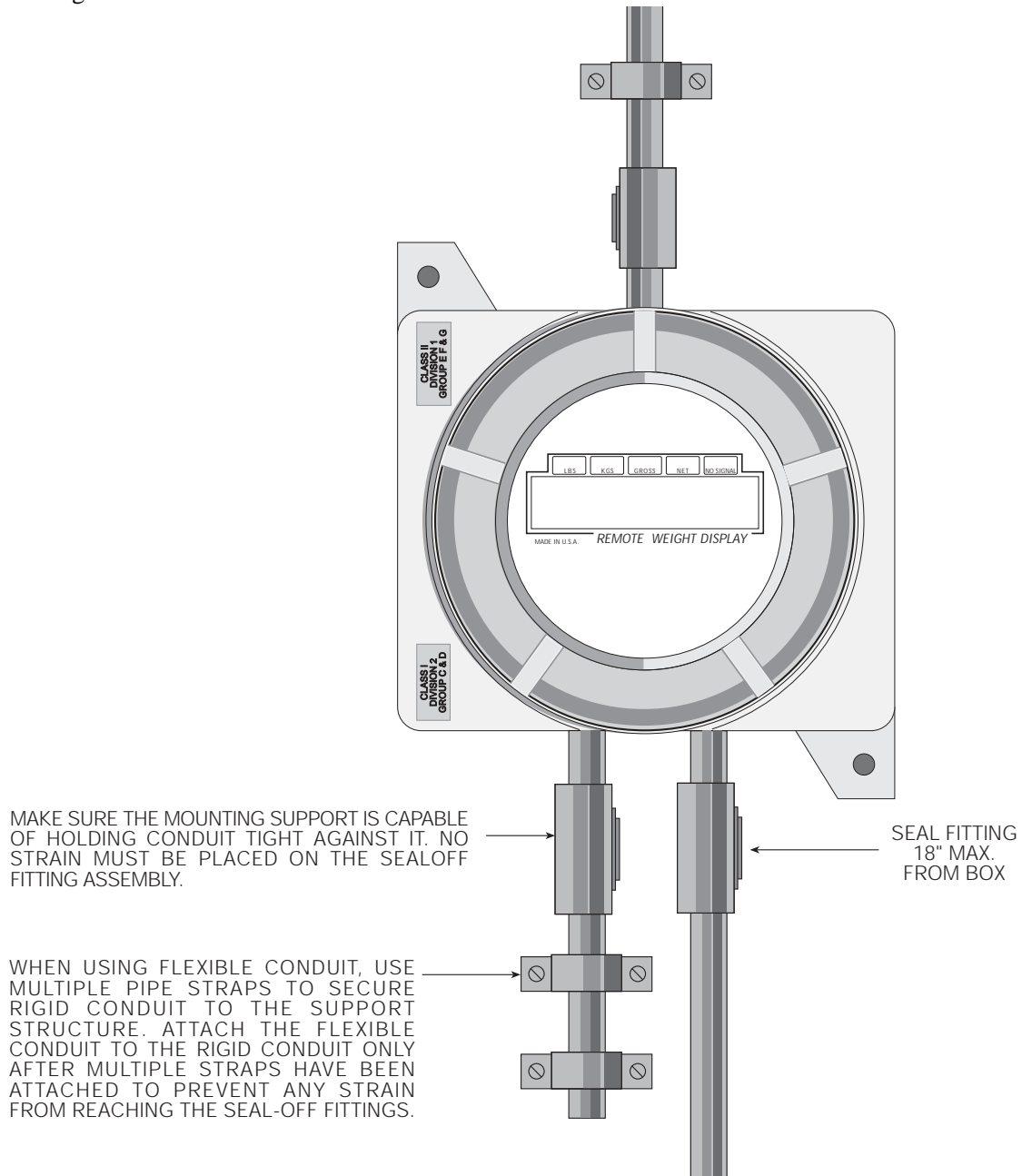

These fittings, once installed and sealed are very difficult to remove so make sure all the wiring has been double checked before beginning. If rigid conduit is not being used for connection to the scale base, be sure to install an approved strain relief fitting to avoid pulling the wires out of the sealoff fittings in an accident. Doing so would open a flame path to the enclosure and defeat its purpose.

Note: *The inside of an explosion proof enclosure is considered a Division II area when the enclosure has been properly sealed.*

2.3 Cabling and Conduit Runs

2.3.1 Cabling

There are two types of cables that pass through a sealoff fitting, single conductor and multi conductor.

Single Conductor Cabling

Single conductor cables are typically redundant ground wires (used with resistive intrinsic safety barrier). Due to the nature of the method by which insulation is applied to wire, a single conductor wire (single or multi strand) can be considered gas tight. It is not necessary to strip the insulation back ahead of entry into the safe area. Single conductor cables will pass through a sealoff fitting as shown below.

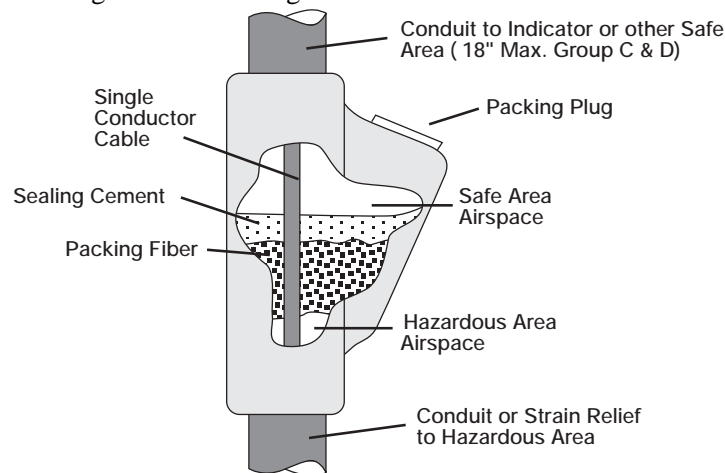

Figure 2-1. Single Conductor Cable

Multi Conductor Cabling

Multi conductor cables may be load cell cables, AC power, serial data inputs or other signals. Because of the airspace that typically exists within the outer insulation of a multi conductor cable, they cannot be considered gas tight. Therefore, to insure that the explosion proof enclosure is allowed to vent internal pressure appropriately, the outer insulation must be removed back to the point ahead of entry into the safe area. Multi conductor cables will pass through a sealoff fitting as shown below.

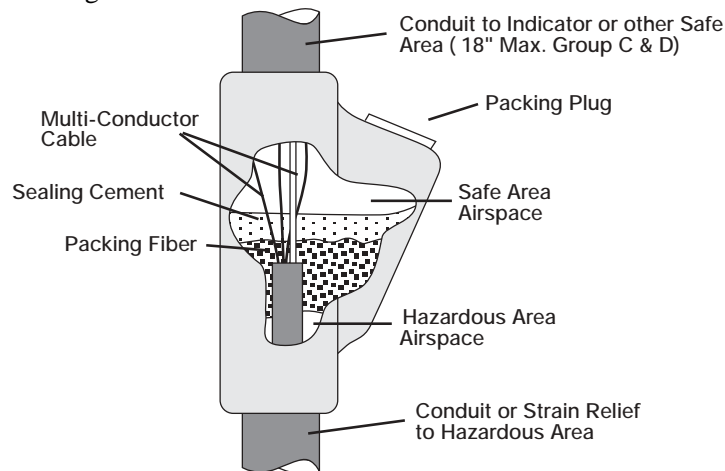

Figure 2-2. Multi Conductor Cable

A sealing fitting must be installed within 18" of the enclosure for Groups C-G and 6" for Groups A and B.

Using the enclosed packing fiber and sealing cement, follow the directions for sealing the sealoff fittings carefully. Make sure there are no openings, no matter how small to the outside.



Warning

An enclosure without sealoff fittings correctly installed and sealed is not explosion proof therefore can pose serious injury or death.

2.3.2 Conduit Runs

Conduit can be run either vertically or horizontally. But either way the conduit must be sealed properly to maintain the explosion proof integrity of the unit. The following paragraphs explain the proper way to install a conduit run and the sealing fittings.

Horizontal Conduit Runs

Install the fitting with covered filling opening facing up. Remove the threaded cover and pack Adaco® packing fiber around and between cables at both ends of fitting to block the flow of cement into conduits. Packing fiber must not project into the main cavity of fitting. The cavity length free of packing fiber must be at least equal to inside diameter of conduit but not less than 5/8".

Mix the cement per label instructions using the enclosed shipping container. Fill the container with clean cold water to "water line" (make sure not to exceed required amount of water). Gradually pour cement from the plastic bag into water and stir thoroughly for proper mixture. Fill the fitting in one continuous pour to the top of filling opening within five minutes after mixing cement. Tamp with a blunt stick to expel any air bubbles. Install and tighten filling opening cover.

Fittings requiring more than 16 oz. of cement must be filled from a single mixture of cement and water. Do not pour in stages.



Caution

Water-mix sealing compound should not be poured or installed at temperatures below 35° F. Adaco no. 1 sealing cement must be used as a part of Adalet UL listed fittings.

Vertical Conduit Runs

Install the fitting with angled fill plug or cap fill plug towards the top. Remove angled fill plug, large hole plug or threaded cover. Pack Adaco packing fiber around and between cables at lower end of sealing fitting to block flow of cement into conduit. Packing fiber must not project into main cavity of fitting. Install and tighten large plug or threaded cover with fill plug facing up but do not install fill plugs at this time.

Mix the cement per label instructions using the enclosed shipping container. Fill the container with clean cold water to "water line" (make sure not to exceed required amount of water). Gradually pour cement from the plastic bag into water and stir thoroughly for proper mixture. Fill the fitting in one continuous pour to the top of filling opening within five minutes after mixing cement. Tamp with a blunt stick to expel any air bubbles. Install and tighten fill plug.

2.4 AC Power Wiring

Electrical connections made in an explosion proof installation are made through rigid steel conduit through threaded openings in the back or sides of the enclosure and must comply with the National Electrical Code for installation of equipment in hazardous areas (NEC Article 504, *Intrinsically Safe Systems*).

Connect the black wire (AC Hot) to terminal strip J1-#3 on the CPU board located in the bottom of the enclosure (shown below).

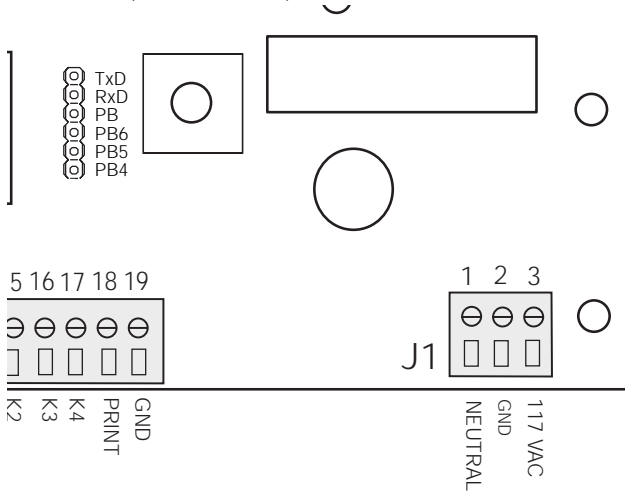

Figure 2-3. J1 Location on CPU Board

Connect the neutral wire (white) to terminal J1-#1, and the ground wire (green) to terminal J1-#2. Use a #16 AWG or smaller wire and strip approximately 3/16" and insert it beneath the compression plate in the connector. Tighten the terminal with a screwdriver and test the connection by pulling gently on the wire.

3.0 Indicator Setup

This section is provided to help the installer set up indicators to the EL232 XPCD. You must determine what indicator will supply the data to the EL232 XPCD. Once this is determined, there are certain setup parameters which you need to know depending on which indicator is chosen.

The EL232 XPCD supports the following scale formats and are listed in Table 3-1:

- UMC Series
- General Freedom I and II
- Electroscale 560
- A & D Instruments 4322, 4323, and 4316
- Weightronix WI-110 and WI-120
- Toledo indicators with “high speed data format”
- Flex-weigh DWM-4
- Analogic AN5315, AN5316, AN5322
- Masstron M-2500 and M-5000
- Fairbanks 90-164 series
- Streeter Richardson 9000
- Cardinal 738
- Instruments with programmable ASCII output
- Generic smart receiver mode

3.1 Serial Data Inputs

The EL232 XPCD can accept serial ASCII data sent in RS232C, 20 mA active, or 20 mA passive current loop formats. These formats determine the electrical way that data is transmitted. The EL232 XPCD can read the data transmission strings sent by 12 of the more popular scale indicator families as shown in Table 3-1. It cannot read data from indicators not included in this list unless the formatting exactly matches one on the list (or if you have a custom program).

Note: Set up the EL232 XPCD on the bench with the indicator you intend to use before taking it to the installation site.

Brand	Model	Interface	Baud Rate	Data Format/Notes
Condec	1000 - 2000 series	Continuous	1200 or 4800	See Figure 3-1
	555/600/700		1200 to 9600	
General Freedom	Series I	RS232	1200 to 9600	7 data bits, parity - odd,
	Series II	RS232		
Electroscale	560	Current loop or RS232 in continuous mode	1200	See Figure 3-2
A & D Instruments	4322, 4321, 4316	Current loop -passive or RS232	2400	-
Weightronix	110 and 120	Current loop or RS232	1200 to 9600	-
Toledo	-	Current loop (active or passive)	4800	-
Flex-Weigh DWM-4	-	Current loop (active or passive)	1200 to 9600	Data preamble - FF, FF, FF postamble FF FF 0A
Analogic	AN5315, AN5316, AN5322	Current loop or RS232 in continuous mode	1200 to 9600	See Figure 3-3

Table 3-1. Indicator Setup Parameters

Brand	Model	Interface	Baud Rate	Data Format/Notes
Masstron	M2500, M5000	Continuous	4800	-
Fairbanks	90-164	Continuous current loop via port C	1200	-
Streeter Amet	9000	Current loop	1200, 2400, 9600	-
Cardinal	738	Current loop or RS232 using S3=10000100	1200 to 9600	See Figure 3-4
Generic smart receiver	N/A	RS232 or current loop	1200 to 9600	Can receive serial data in a wide variety of intuitive formats. Use when all else fails.

Table 3-1. Indicator Setup Parameters (Continued)

Any device that has a programmable ASCII output can be used with the EL232 XPCD. Set the device to emulate any of the following:

3.1.1 Condec Data Format

Figure 3-1 shows the Condec UMC series continuous output data format.

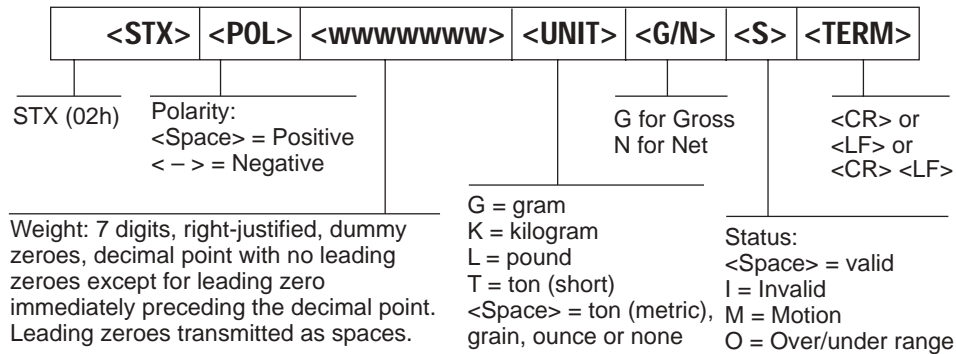

Figure 3-1. Condec Continuous Output Data Format

3.1.2 Electroscale Data Format

Figure 3-2 shows the Electroscale continuous output data format.

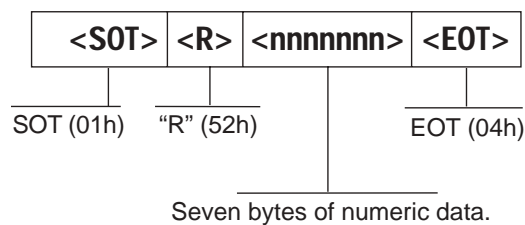

Figure 3-2. Electroscale Continuous Output Data Format

3.1.3 Analogic Data Format

Figure 3-3 shows the Analogic continuous output data format.

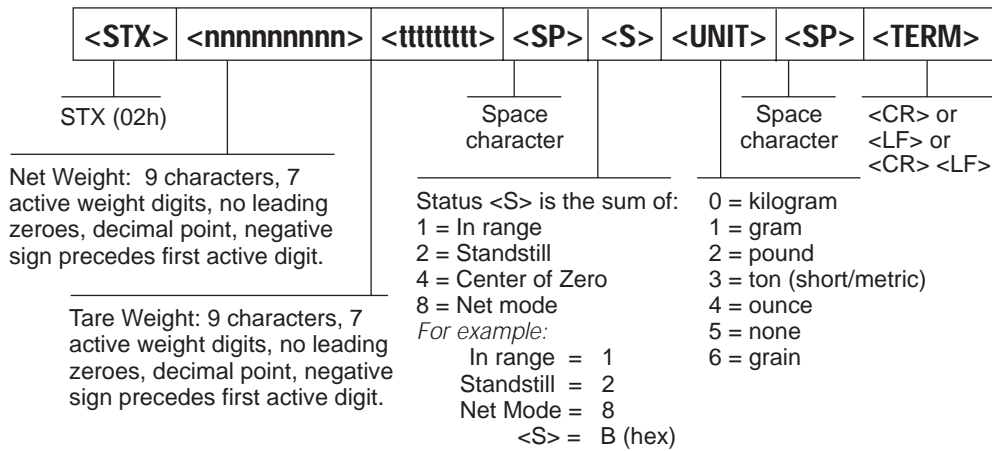

Figure 3-3. Analogic Continuous Output Data Format

3.1.4 Cardinal Data Format

Figure 3-4 shows the Cardinal continuous output data format.

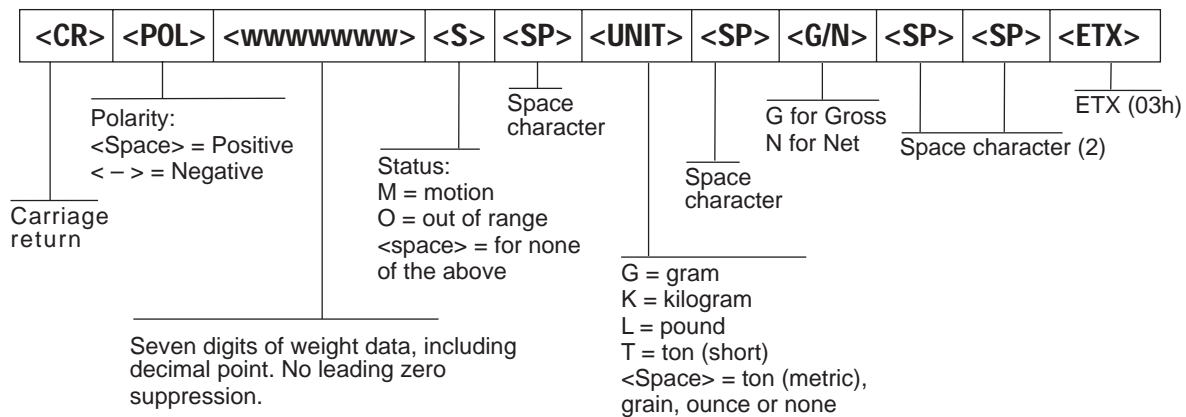

Figure 3-4. Cardinal Continuous Output Data Format

3.2 Serial Data Input

Some weight indicators have multiple outputs. Some can have two or more RS232 outputs or current loop outputs which can be active or passive. The preferred interface is an active current loop output from the weight indicator. A passive current loop is second in preference, and RS232 being the least desirable. The transmitted data must be continuous and demand ports are unusable. Information is explained in further detail in the following sections.

3.2.1 RS232 C

Data is transmitted as a voltage and alternates between +10 VDC and -11 VDC. Hybrid RS232 signals can swing between other voltage ranges as long as the positive swing is greater than 4 VDC and the negative is less than - 1 VDC. RS232 is ground referenced and therefore, connects the ground planes of the sending and receiving instruments. RS232 should never be run more than 50 feet. It may work, but it may not work well or all the time. Long RS232 data cables can act as a conduit for lightning or other electrical noise to the instrument. If you need longer cable runs, use a 20 mA current loop.

Connect RS232 wiring as shown in Figure 3-5. Strip the wires approximately 3/16" and insert them into the connectors as shown. Tighten the connectors and test the tightness by gently pulling on the wires.

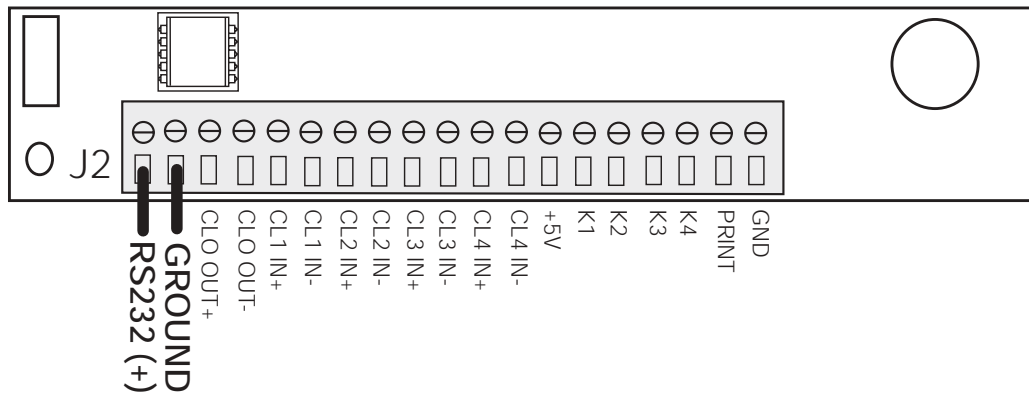

Figure 3-5. RS232 C Input Hookup

The RS232 receiver in the EL232 XPCD is made from discrete components and requires a lower current than most integrated circuit RS232 receivers. It is very difficult to damage and holds up under most conditions.

3.2.2 20 mA Active Current Loop Input

Data is transmitted as a current and is passed through an optical isolator. This current causes an LED to emit light onto a photo transistor, which converts this light into a TTL signal. Current transmission can be made over long distances and are quite immune from transient voltage or RFI/EMI noise. The distance a current loop can transmit is limited by the voltage source available to the current loop and the speed of transmission which data is sent. Normally a current loop should not send data at speeds greater than 4800 baud.

An active current loop means that the instrument which sends the data also supplies the voltage to power the loop. This voltage can be as small as 5 VDC to as much as 24 VDC. When the loop goes through an optocoupler, a drop occurs. This drop is about 2 VDC. A current loop can power as many drops as there is voltage to power the loop. For example, if a current loop is powered by 5 VDC, it can normally drive two drops. If the same loop were powered by 24 VDC, it could power about 11 remote displays or other devices.

Determine that your indicator has an active current loop and connect it as shown in Figure 3-6. Strip the wires approximately 3/16" and insert them into the connector as shown. Tighten the connectors and test the tightness by gently pulling on the wires.

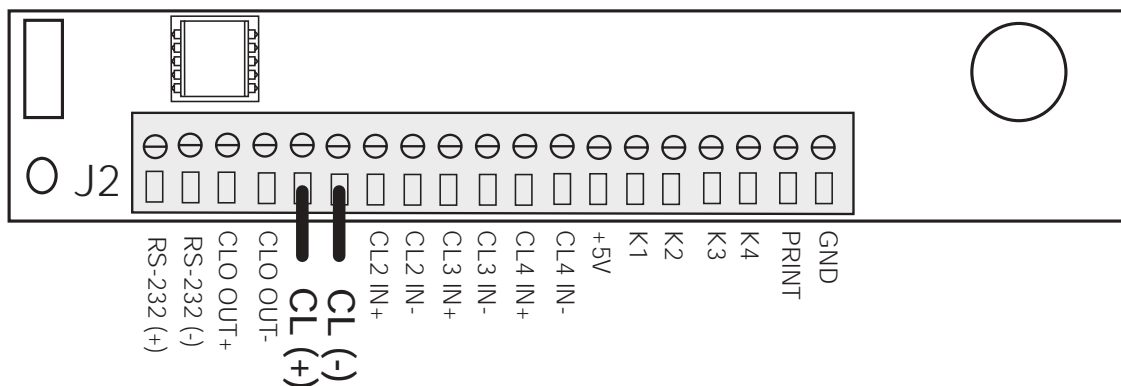

Figure 3-6. 20 mA Active Current Loop Input Hookup

The 20 mA receiver in the EL232 XPCD is a HP-4200 and requires current swings of less than 4 mA as a mark and greater than 12 mA for a space. The output of the HP-4200 is a TTL signal which appears at pin #7 of the chip.

3.2.3 20 mA Passive Current Loop Input

In this configuration, an external voltage or current source is connected to a current switch in the sending instrument. Data is transmitted as a current and is passed through an optical isolator. This current causes an LED to emit light onto a photo transistor, which converts this light into a TTL signal. Current transmission can be made over long distances and are quite immune from transient voltage or RFI/EMI noise. The distance a current loop can transmit is limited by the voltage source available to the current loop and the speed of transmission which data is sent. Normally a current loop should not send data at speeds great than 4800 baud.

A passive current loop means that the instrument which sends the data does not supply the voltage to power the loop. The voltage to power the loop must come from an external power supply or receiver. This voltage can be as small as 5 VDC to as much as 24 VDC. When the loop goes through an optocoupler, a drop occurs. This drop is about 2 VDC. A current loop can power as many drops as there is voltage to power the loop. For example, if a current loop is powered by 5 VDC, it can normally only drive two drops. If the same loop were powered by 24 VDC, it could power about 11 remote displays.

The EL232 XPCD can supply power to a passive current loop. This voltage supplies about 8 VDC for use in the loop.

Determine that your indicator has a passive current loop and connect it as shown in Figure 3-7. Strip the wires approximately 3/16" and insert them into the connector as shown. Tighten the connectors and test the tightness by gently pulling on the wires.

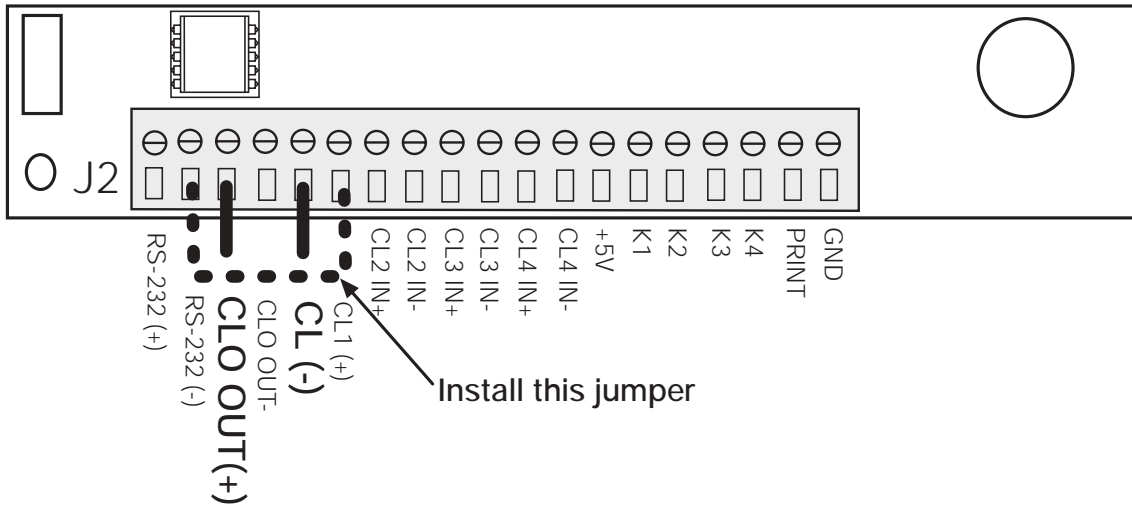

Figure 3-7. 20 mA Passive Current Loop Hookup

Note: The serial output is not available when using this input type without board modifications. Consult the factory for details.

3.3 Configuration of the EL232 XPCD

To configure the EL232 XPCD, you must know the following:

- Baud rate
- Indicator type
- Data format - RS232 or 20 mA current loop

Once this information is known, it is entered through SW1, the eight-position DIP switch on the upper left hand corner of the CPU board, shown below:

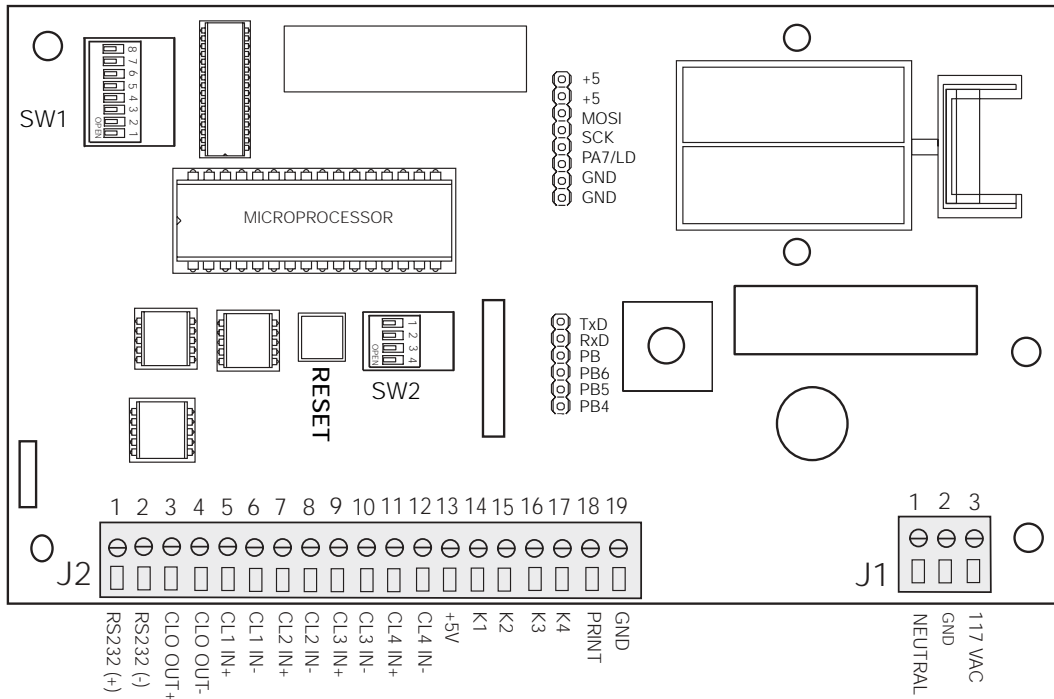

Figure 3-8. RS232 XPCD CPU Board

Enter the correct values from Table 3-2.

Baud Rate		
Speed	SW1-1	SW1-2
1200	On	On
2400	Off	On
4800	On	Off
9600	Off	Off

Table 3-2. Baud Rate Setting

Refer to Table 3-3 on page 18 for specific switch settings for applicable indicators.

The power must be off when these values are changed. If the power is on, press the **Reset** switch on the CPU board to enter the new values (see Figure 3-9).

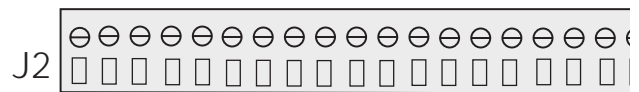
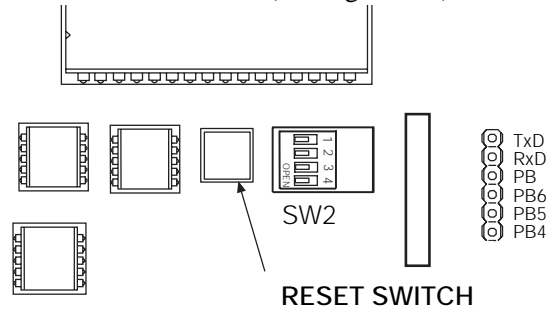

Figure 3-9. Reset Switch Location

Indicator				
Indicator Type	SW1-3	SW1-4	SW1-5	SW1-6
Condec	On	On	On	On
General Freedom	Off	On	On	On
Electro 560	On	Off	On	On
A n D	Off	Off	On	On
WI-110, WI-120	On	On	Off	On
Toledo	Off	On	Off	On
Flexweigh	On	Off	Off	On
Analogic	Off	Off	Off	On
Masstron	On	On	On	Off
Fairbanks	Off	On	On	Off
Streeter Richardson	On	Off	On	Off
Cardinal 738	Off	Off	On	Off
Generic	Off	Off	Off	Off

Table 3-3. Indicator Switch Settings

3.3.1 Loss of Signal Display

Press the Reset switch to enter new values into the EL232 XPCD, or turn off the power, or wait approximately 30 seconds and the EL232 XPCD will reset itself.

The following tables illustrate switch settings for the loss of signal display.

Loss of Signal Display	
Display	SW1-7
Last data	Off
-----	On

Table 3-4. Loss of Signal Display

Input Signal Type	
Interface	SW1-8
RS232	On
20 mA	Off

Table 3-5. Input Signal Type

3.4 Serial Data Output

The EL232 XPCD comes standard with an active 20 mA current loop transmitter which echoes the serial data received by the EL232 XPCD. This data is echoed as a 20 mA loop regardless of whether the input source was RS232 or current loop.

The output is active and supplies current from a voltage source of approximately 8 VDC. The current transmitter is an HP-4100 and can transmit data cleanly at 9600 baud. The HP-4100 supplies mark currents of >12 mA and space currents of <2 mA.

Certain scale industry remote displays and printers use darlington type optocouplers as input devices. Unbiased 4N33 type opto isolators can be turned on by 2 mA. These are not true current loop receivers. If a device which the EL232 XPCD is transmitting to cannot properly receive the data, change the 4N33 to a 4N25 opto isolators and the problem will normally disappear.

Figure 3-10 illustrates how to connect the current loop output of the EL232 XPCD.

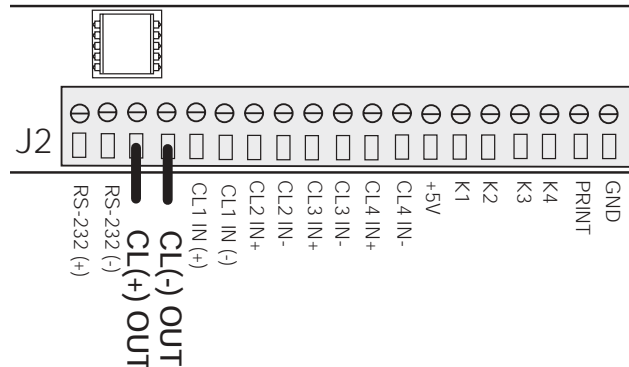

Figure 3-10. 20 mA Active Current Loop Output

You can check the current loop output with a simple jumper connected between pin J2-3 and J2-4. The LED on the CPU should flash on and off when data is transmitted.

Note: When using a passive current loop input, the serial output is not available. Consult the factory for additional information.

4.0 EL232 XPCD Operation

Prior to powering up the EL232 XPCD, double check wiring and setup making sure all wiring is properly terminated.

Once power is applied, the EL232 XPCD enters the power on clear mode. All status switches are read at this time and the unit is configured for baud rate, indicator type, and input signal type. The EL232 XPCD display goes through a power up sequence which can provide valuable information about the operating condition and setup of the unit.

4.1 Lamp Test

The first display during power on clear is a lamp test. This test lights all displays, decimal points, and annunciators. Proper indication is “**8.8.8.8.8.**” with five illuminated LEDs above the main display.

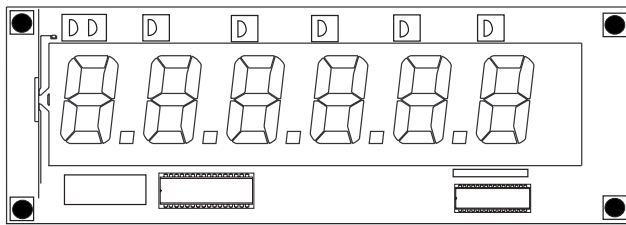

Figure 4-1. EL232 XPCD LED Display

4.2 Software Revision

The software revision number which is in the EL232 XPCD is displayed. The display shows **rEV 2.6** for normal revision 2.6 program. This helps identify specially modified software.

4.3 Current Baud Rate Setting

The EL232 XPCD next shows the current baud rate setting it had read from switch SW1. The display shows, **bAUd12** for 1200 baud, **bAUd24** for 2400 baud, **bAUd48** for 4800 baud, or **bAUd96** for 9600 baud.

4.4 Input Signal Type

The display shows **rS232** for RS232 data setting or **C LOOP** for current loop input. Refer to Section 3.1 for further information on setting the correct input data type.

4.5 Indicator Type

Finally, the EL232 XPCD shows the indicator type which the EL232 XPCD is receiving. This is displayed as **Ind 1** where the 1 can be an indicator number from 1 to 12. Refer to Table 4-1 for a numerical list of indicator types.

Numeric Display	Indicator Type
1	Condec, UMC
2	General Freedom
3	Electroscale 560
4	A N D Instruments
5	Weightronix 110, 120
6	Toledo Hi Speed data format
7	Flex-weigh DWM-4
8	Analogic
9	Masstron
10	Fairbanks
11	Streeter Richardson 9000
12	Cardinal 738
16	Generic Format

Table 4-1. Numeric Indicator Type

From the power on clear sequence, the current status of the display and the current setup information can be verified. This can be done at any time by pressing the reset switch (see Figure 3-9 on page 17) on the CPU or by removing AC power from the unit.

4.6 Receiving Data for the First Time

After the power up sequence, the EL232 XPCD synchronizes with the incoming serial data line and looks for data to receive. If no readable data is received within a few seconds, the *NO SIG LED* in the upper right of the display is lit and the display shows, “-----”. This LED is also lit if transmission should stop for more than 8-10 seconds during normal operation.

SW1-7 selects the data displayed during a loss of signal state (Section 3.3.1). If SW1-07 is open, the last value received is displayed continuously. If this switch is closed, the display again shows, “-----” until readable data is again received. This can be used to alert the operator that data on the display may not be valid. When the data returns to normal, the display updates and the *NO SIG* lamp goes out.

When communication is established, the current weight value is displayed. Decimal points are inserted into the display as indicated by the meter. If the data format from the meter makes LB, Kg, Gross or Net status available, the EL232 XPCD displays this information with the appropriate LED status lamps. Some formats do not make this data available. In this case, the LEDs will not be illuminated.

5.0 Appendix

5.1 Troubleshooting

If any of the following conditions are observed:

- Suspect water or leakage in the enclosure
- The glass becomes scratched, cracked, chipped, or pitted.
- A sealing fitting is sheared off or damaged
- The door is hit by a vehicle or object
- If you notice or suspect any damage to the unit

Do the following:

- Clear area of all personnel and notify plant safety
- Shut down all power to the unit at the source and lock out
- When the area has been cleared of the hazard and plant safety has declared the area safe for workers to enter, call your scale dealer
- Do not attempt to restart the unit until all damaged parts have been replaced and the unit has been tested.

The most common problems are indicator incompatibility, mis-wiring, and mis-programming both in the indicator and in the EL232 XPCD setup. Double check the output of the meter and make sure something is being transmitted. Use an oscilloscope, printer, logic probe, or voltmeter to verify that the meter is sending continuous data. Use a logic probe to check the signal on the EL232 XPCD CPU board to see if data is actually being received. Connect the probe as shown below.

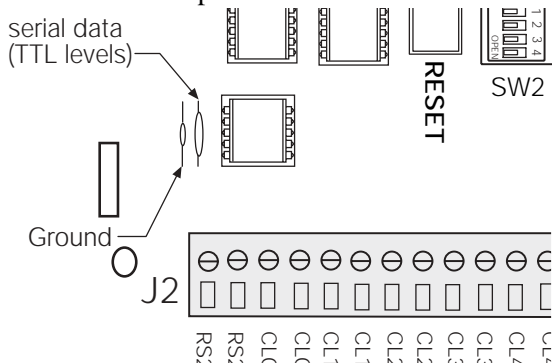

Figure 5-1. Logic Probe Location

5.2 Recommended Spare Parts

The following table consists of the recommended spare parts for EL232 XPCD, rev. 3.5 board sets.

RLWS Part Number	Description	Quantity
21036	Display board	1
21035	CPU board	1
16347	Serial transmitter chip	2
16348	Serial receiver chip	2
16445	Fuse .5A Slo-blo	1
22134	Display lens	1

Table 5-1. Recommended Spare Parts List

5.3 Specifications

Display:

High-intensity, red LED, 0.8" (20.3mm) high digits

Input Voltage:

117 VAC, 60 Hz

Amps:

40 mA

Weight:

Approximately 25 lb (11.3 kg)

Baud Rate:

1200, 2400, 4800, and 9600

Interfaces:

20 mA and RS232 standard. The EL232 XPCD can communicate, as shipped, with twelve of the most common scale indicator families currently available. Please consult factory for model numbers and interface requirements.

Warranty:

One year limited warranty

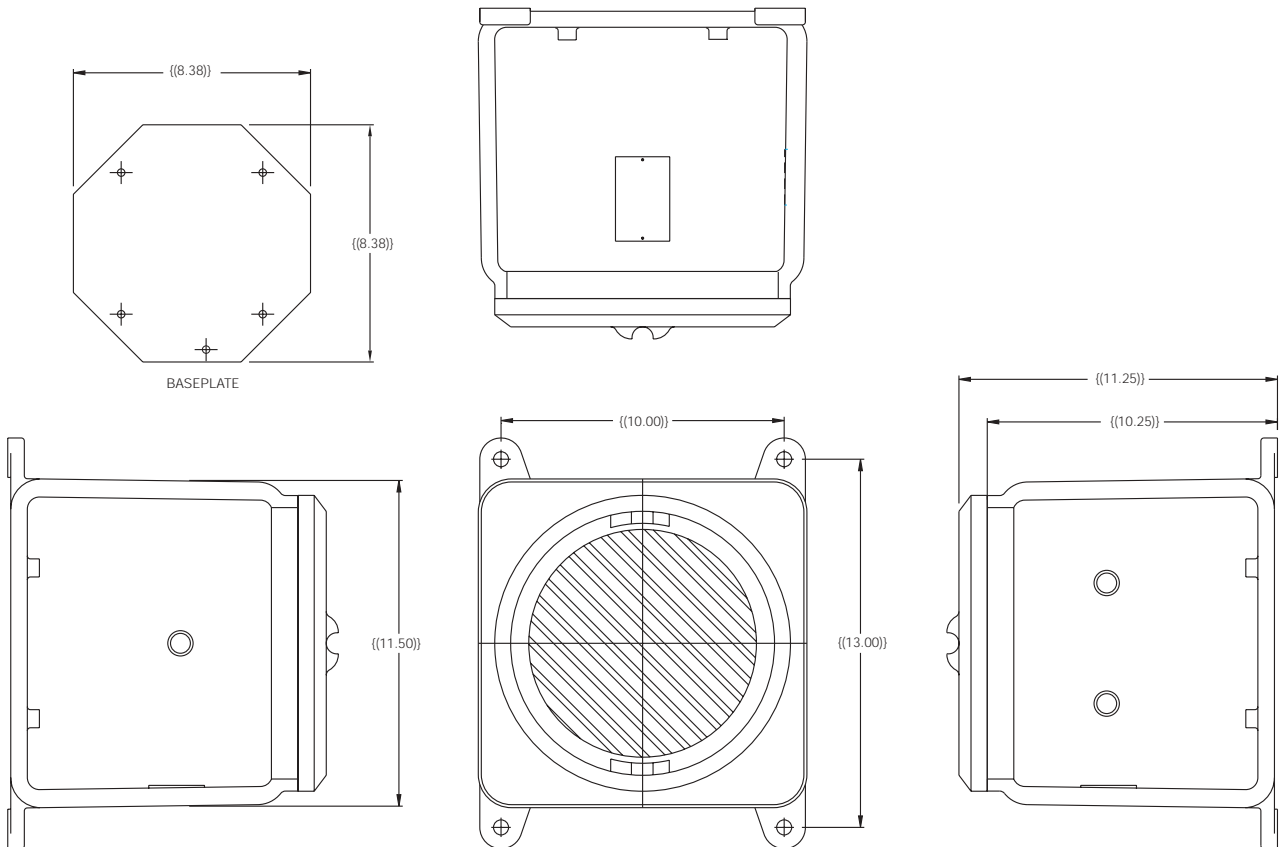

EL232 XPCD Limited Warranty

Rice Lake Weighing Systems (RLWS) warrants that all RLWS equipment and systems properly installed by a Distributor or Original Equipment Manufacturer (OEM) will operate per written specifications as confirmed by the Distributor/OEM and accepted by RLWS. All systems and components are warranted against defects in materials and workmanship for one year.

RLWS warrants that the equipment sold hereunder will conform to the current written specifications authorized by RLWS. RLWS warrants the equipment against faulty workmanship and defective materials. If any equipment fails to conform to these warranties, RLWS will, at its option, repair or replace such goods returned within the warranty period subject to the following conditions:

- Upon discovery by Buyer of such nonconformity, RLWS will be given prompt written notice with a detailed explanation of the alleged deficiencies.
- Individual electronic components returned to RLWS for warranty purposes must be packaged to prevent electrostatic discharge (ESD) damage in shipment. Packaging requirements are listed in a publication, *Protecting Your Components From Static Damage in Shipment*, available from RLWS Equipment Return Department.
- Examination of such equipment by RLWS confirms that the nonconformity actually exists, and was not caused by accident, misuse, neglect, alteration, improper installation, improper repair or improper testing; RLWS shall be the sole judge of all alleged non-conformities.
- Such equipment has not been modified, altered, or changed by any person other than RLWS or its duly authorized repair agents.
- RLWS will have a reasonable time to repair or replace the defective equipment. Buyer is responsible for shipping charges both ways.
- In no event will RLWS be responsible for travel time or on-location repairs, including assembly or disassembly of equipment, nor will RLWS be liable for the cost of any repairs made by others.

THESE WARRANTIES EXCLUDE ALL OTHER WARRANTIES, EXPRESSED OR IMPLIED, INCLUDING WITHOUT LIMITATION WARRANTIES OF MERCHANTABILITY OR FITNESS FOR A PARTICULAR PURPOSE. NEITHER RLWS NOR DISTRIBUTOR WILL, IN ANY EVENT, BE LIABLE FOR INCIDENTAL OR CONSEQUENTIAL DAMAGES.

RLWS AND BUYER AGREE THAT RLWS'S SOLE AND EXCLUSIVE LIABILITY HEREUNDER IS LIMITED TO REPAIR OR REPLACEMENT OF SUCH GOODS. IN ACCEPTING THIS WARRANTY, THE BUYER WAIVES ANY AND ALL OTHER CLAIMS TO WARRANTY.

SHOULD THE SELLER BE OTHER THAN RLWS, THE BUYER AGREES TO LOOK ONLY TO THE SELLER FOR WARRANTY CLAIMS.

NO TERMS, CONDITIONS, UNDERSTANDING, OR AGREEMENTS PURPORTING TO MODIFY THE TERMS OF THIS WARRANTY SHALL HAVE ANY LEGAL EFFECT UNLESS MADE IN WRITING AND SIGNED BY A CORPORATE OFFICER OF RLWS AND THE BUYER.

© 2002 Rice Lake Weighing Systems, Inc. Rice Lake, WI USA. All Rights Reserved.

RICE LAKE WEIGHING SYSTEMS • 230 WEST COLEMAN STREET • RICE LAKE, WISCONSIN 54868 • USA



230 W. Coleman St. • Rice Lake, WI 54868 • USA
U.S. 800-472-6703 • Canada/Mexico 800-321-6703
International 715-234-9171

www.ricelake.com

[mobile: m.ricelake.com](http://m.ricelake.com)

© 2011 Rice Lake Weighing Systems PN 16942 06/11