

U Series

Farmbars

Operator's Manual

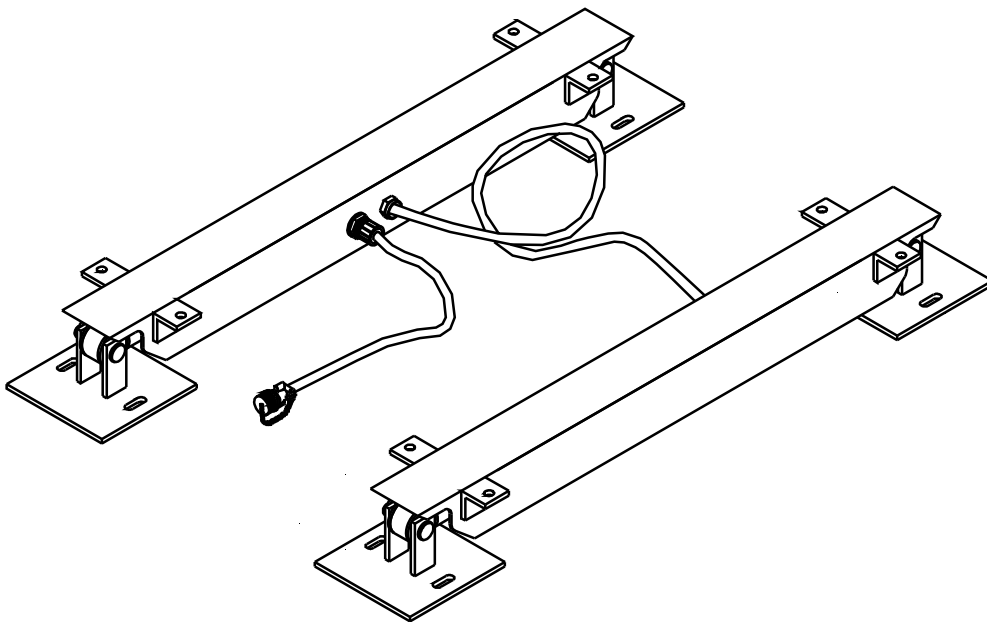

Contents

- 1.0 Introduction..... 1**
 - 1.1 Safety 1
- 2.0 Technical Specifications..... 2**
- 3.0 Installation..... 3**
- 4.0 Parts List..... 4**
- 5.0 Maintenance..... 6**
 - 5.1 Calibration 6
- 6.0 Troubleshooting..... 8**
 - 6.1 General 8
 - 6.2 Drifting 8
 - 6.3 Abnormally Large Reading 8
- 7.0 Load Cell Replacement..... 10**
- U Series Limited Warranty..... 11**
- For More Information..... 12**



Technical training seminars are available through Rice Lake Weighing Systems. Course descriptions and dates can be viewed at www.ricelake.com/training or obtained by calling 715-234-9171 and asking for the training department.



Rice Lake continually offers web-based video training on a growing selection of product-related topics at no cost. Visit www.ricelake.com/webinars.

1.0 Introduction

The electronic weighing equipment you have purchased has been manufactured using high quality components and the latest production techniques to ensure reliable, trouble-free operation for years to come. To obtain the best possible performance from your weighing equipment, please read this manual carefully.

The farmbars consist of a steel tube containing load cell mounts, load cells, and mounting pads. Each farmbar contains two factory calibrated load cells. The farmbars are of solid construction and, therefore, do not require any horizontal checking (check rods). Farmbars are designed to withstand horizontal loads in the same range as their capacity without any damage. Care should be taken to remove the possibility of horizontal impacts with the scale platform. Impacts or collisions tend to create very high forces.

The versatility of the farmbars allows any platform or container to become a weigh scale by placing a set of bars beneath them. Various indicator combinations can be matched to the farmbars to meet specialized applications.

1.1 Safety

Safety Symbol Definitions:



Indicates a potentially hazardous situation that, if not avoided, could result in serious injury or death, and includes hazards that are exposed when guards are removed.



Important

Indicates information about procedures that, if not observed, could result in damage to equipment or corruption to and loss of data.

General Safety



Do not operate or work on this equipment unless you have read and understand the instructions and warnings in this Manual. Failure to follow the instructions or heed the warnings could result in injury or death. Contact any Rice Lake Weighing System dealer for replacement manuals. Proper care is your responsibility.



Failure to heed may result in serious injury or death.

DO NOT allow minors (children) or inexperienced persons to operate this unit.

DO NOT operate without all shields and guards in place.

DO NOT jump on the scale.

DO NOT use for purposes other than weight taking.

DO NOT place fingers into slots or possible pinch points.

DO NOT use any load bearing component that is worn beyond 5% of the original dimension.

DO NOT use this product if any of the components are cracked.

DO NOT exceed the rated load limit of the unit.

DO NOT make alterations or modifications to the unit.

DO NOT remove or obscure warning labels.

Keep hands, feet and loose clothing away from moving parts.

2.0 Technical Specifications

For all U Series Farmbars			
	2500U	5000U	10000U
Capacity	2500 lb	5000 lb	10000 lb
Nominal Output	2.5 mV/V		
Max. Excitation Voltage	+15V		
Overall Accuracy Max.	±0.25% of Capacity		
Overall Accuracy Typical	±0.10% of Capacity		
Overall Accuracy (Light Load)	±0.25% of Reading		
Compensated Temp. Range	15 to 100°F		
Operating Temp. Range	-25 to 110°F		
Overload Capacity	150% of Rated Capacity		
Shipping Weight	48 lb	69 lb	110 lb

Table 2-1. Specifications

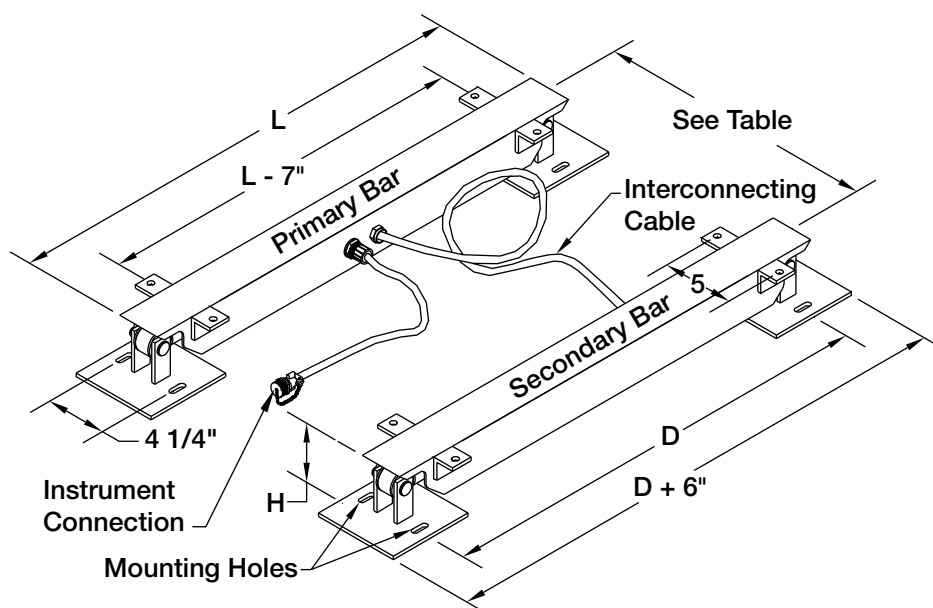

Model	L	D	H	Spread* Distance
2500U	22"	19-3/4"	4"	5'
5000U	26" to 48"	30-3/4"	4"	8'
10000U	3' to 6'	45-3/4"	4"	8'

Table 2-2. Dimensions

* Specify spread distance if any other length is required.

3.0 Installation

The following points are to help ensure proper installation of the farmbars. If further assistance is required, please contact your nearest factory or dealer.

! Important *When planning an outdoor location for the farmbars, choose a site which will allow for adequate drainage away from the scale. Immersing the load cells in water can damage the load cells and void the warranty.*

- Try to install the farmbars on a firm, level surface. The farmbars do not have to be installed perfectly level, but a substantial slope will decrease accuracy. All weight transfer must take place through the pads at the end of each farmbar. Make sure there is no contact between the ground and the center of the load bar.
- Install the farmbars in the upright position. This will allow for accurate weighing and will help keep any foreign material out of the farmbar.
- Do not drill into or weld onto the farmbars as this may cause internal structural or electrical damage. Secure the farmbars to the weighing platform using the mounting lugs supplied.
- Install the cable so that it is not stepped on or run over. Cable failure due to physical damage is not covered under warranty.
- When constructing the weighing platform, ensure excessive sagging does not occur. This may cause inaccuracies in weighing and could damage the cable.

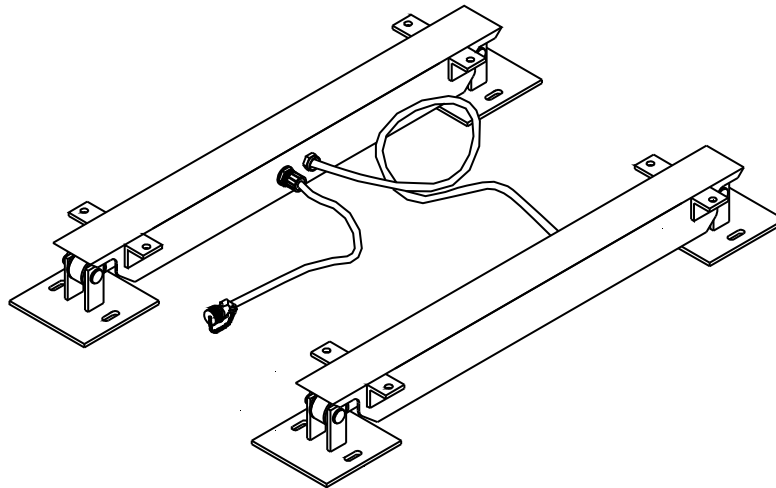

Figure 3-1. U Series Farmbars

4.0 Parts List

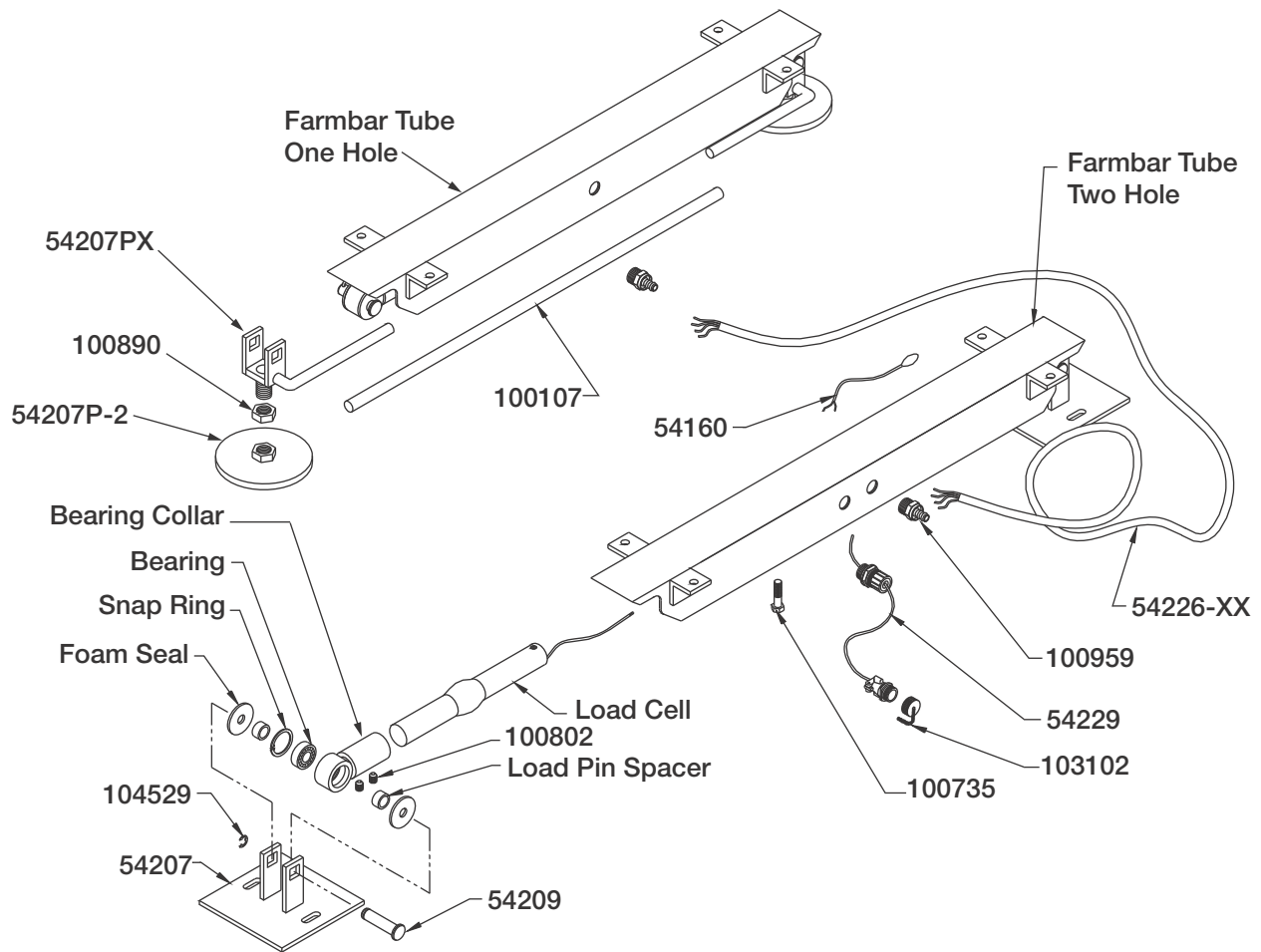

Figure 4-1. Farmbars Illustrated Parts

Description	2500U			5000U			10000U		
	Part #	RLWS Part #	Qty.	Part #	RLWS Part #	Qty.	Part #	RLWS Part #	Qty.
Bearing	101211	127238	4	101211	127238	4	101212	127239	4
Bearing Collar	54203	127765	1	55203	127783	1	56203	127793	4
Foam Seal	101232	126821	4	101232	126821	4	101233	126822	4
*Farmbar Tube-One Hole	54206-5		1	55206-5-XX		1	56206-5-XX		1
*Farmbar Tube-Two Hole	54206-3		1	55206-3-XX		1	56206-3-XX		1
Load Cell	54201		2	55201		4	56201		4
Load Pin Spacer	54210	127775	8	54210	127775	8	56210	127796	8
Snap Ring	101226	126806	4	101226	126806	4	101227	126807	4
Hex Mounting Bolt	100735	126979	2	100735	126979	4	100735	126979	4
**Bearing Collar Assembly	54202		4	55202		4	56202		4

Table 4-1. Farmbars Parts List

*Specify Length in inches (i.e. 55206-3-33), 2500U only comes in 22" lengths.

**Assembly includes, Bearing Collar, Bearing, Snap Ring, Foam Seals and set screws.

Description	Part #	RLWS Part #	Qty
Compensation Resistor	54160	127763	1
Pad	54207	127770	4
Load Pin	54209	127774	4
Inline Connector, 3' S.S	54229	127777	1
Operator's Manual	54250	127468	1
**Stop Tube	100107	13722	2
Set Screw (3/8x3/8)	100802	89091	8
Nut, Jam 3/4"	100890	126974	4
Washer (5/8 Flat SAE)	100931		4
Hose Barb Connector	100959	126893	2
Cotter Pin (5/32"x1")	100963	15244	4
Dust Cap & Chain	103102	126885	1
Pad Base Plate	54207P-2	127771	4
Pad Upright	54207PX-1		4
*Cable w/Rubber Hose	54226-XX	127776	1

Table 4-2. Parts Common to all U Series Farmbars

*Cable Length in inches (i.e. 54226-96)

**Portable Pad 54207PA-1 (Clockwise), 54207PB-2 (Counter Clockwise) Direction is determined by look down from top of the load bar and determining direction the stop rod is pointing.

5.0 Maintenance

The most common type of problem that can occur is the load is not supported completely by the farmbar pads. Check around and under the weigh apparatus to see if any debris has collected near the scale. Any ice, dirt, mud or manure that builds up can cause inaccurate readings. The scale should be kept clean to ensure proper operation.

It should also be noted that an excess of debris on top of the scale could cause problems. Depending on the type of scale you have, there may be a limited range of weight you can zero off the scale. Always keep the build up of material on top of the scale to a minimum.

Lubrication of the bearings in your scale is also important. The bearings are located in the bearing collar, as shown in the parts list diagram, see Figure 4-1. Inject grease into the bearings using a syringe at least once every two years. Use a quality, high-pressure grease to lubricate the bearings completely. Do not use an excess of grease – it should lubricate the bearing without bleeding around the foam seal.

5.1 Calibration

All load cells are calibrated at the factory to reduce installation errors. Over the course of time, however, the load cells may drift out of calibration slightly. Normally when a scale's load cells go out of calibration, the digital indicator is adjusted to compensate for this.

The *U Series* farmbars can be calibrated using the indicator front panel, EDP commands, or the *Revolution*[®] configuration utility. Each method consists of the following steps:

- Zero calibration
- Entering the test weight value
- Span calibration
- Optional rezero calibration for test weights using hooks or chains.

The following sections describe the calibration procedure for each of the calibration methods.

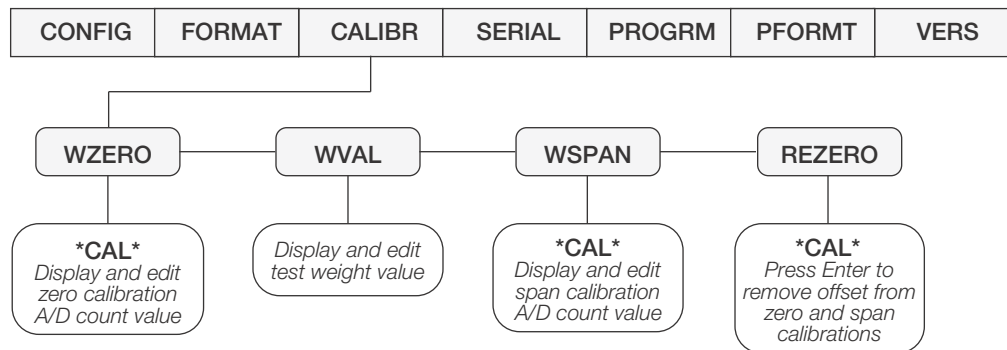

Figure 5-1. Calibration (CALIBR) Menu

Front Panel Calibration

To calibrate the indicator using the front panel, do the following:

1. Place the indicator in setup mode (display reads *CONFIG*) and remove all weight from the scale platform. If your test weights require hooks or chains, place the hooks or chains on the scale for zero calibration.
2. Press \triangleright until the display reads *CALIBR* (see Figure 5-1). Press ∇ to go to zero calibration (*WZERO*).
3. With *WZERO* displayed, press \leftarrow to calibrate zero. The indicator displays **CAL** while calibration is in progress. When complete, the A/D count for the zero calibration is displayed. Press \leftarrow again to save the zero calibration value and go to the next prompt (*WVAL*).
4. With *WVAL* displayed, place test weights on the scale and press \leftarrow to show the test weight value. Use the numeric keypad to enter the actual test weight, then press \leftarrow to save the value and go to span calibration (*WSPAN*).
5. With *WSPAN* displayed, press \leftarrow to calibrate span. The indicator displays **CAL** while calibration is in progress. When complete, the A/D count for the span calibration is displayed. Press \leftarrow again to save the span calibration value and go to the next prompt (*REZERO*).
6. The rezero function is used to remove a calibration offset when hooks or chains are used to hang the test weights.
 - If no other apparatus was used to hang the test weights during calibration, remove the test weights and press \triangle to return to the *CALIBR* menu.
 - If hooks or chains were used during calibration, remove these and the test weights from the scale. With

all weight removed, press \blacktriangleleft to rezero the scale. This function adjusts the zero and span calibration values. The indicator displays *CAL* while the zero and span calibrations are adjusted. When complete, the adjusted A/D count for the zero calibration is displayed. Press \blacktriangleleft to enter the value, then press \blacktriangle to return to the CALIBR menu.

7. Press \blacktriangleleft until the display reads *CONFIG*, then press \blacktriangle to exit setup mode.



Note *To perform the calibration using EDP commands or Revolution[®], consult the indicator operator's manual.*

6.0 Troubleshooting

6.1 General

If you are having trouble with your farmbars, a few simple procedures should help you determine where the problem lies. First, inspect the scale for any physical damage. Take special note of the cable and connectors. Wiggle the cables and connectors while watching the indicator display. If the readout jumps while moving a cable or connector, there is likely a short or loose connection. Repair or replace the cable or connector as appropriate.

6.2 Drifting

If the scale readout is drifting, moisture may be present somewhere in the scale's electrical circuit. Check for moisture in any of the connectors, junction boxes, or farmbars. Dry any location where you suspect moisture is present. If you find a location where moisture is collecting on a regular basis, seal the location with a waterproof sealant.

6.3 Abnormally Large Reading

If the indicator shows a very large number and the readout cannot be changed using the indicators zero adjustment, there may be a problem in the circuit. To locate this type of problem, a series of electrical resistance measurements must be made. To perform these checks, you will need an *accurate* ohmmeter and a soldering iron.

To locate a faulty component with the ohmmeter, start by taking readings in the connector that plugs into the indicator cable (this is the cable the runs into your scale). The connector has four pins labelled A, B, C and D, the following chart lists the appropriate resistance readings. Remember, when making this type of measurement the power must be **OFF**. Further, be careful that your fingers are not making contact with the probes on the ohmmeter – if they are, the reading you take may be incorrect.

Connector Markings	Resistance Readings	Load Cell #
A – C	395Ω	
B – D	350Ω	
A – B	263Ω	I
B – C	308Ω	II
C – D	308Ω	III
D – A	263Ω	V

Table 6-1. Ohmmeter Readings



Note This chart is only valid at a temperature of 22°C. Resistance will vary slightly with temperature.

The readings in Table 6-1 should be within 5 ohms of the value shown. The readings are slightly temperature dependent and as a result will not match Table 6-1 exactly. However, all the readings you take should differ from the table by the same percentage. For example, if the resistance across pins D & C reads $142\Omega \pm 1\Omega$, resistance across pins D & A should also read $142\Omega \pm 1\Omega$. In other words the values equal in Table 6-1 should also be equal when you take your measurements. If the readings correspond to the values in the table an electrical problem in the scale is not likely. If any readings across pins of the connector differ from the chart, each load cell must be checked individually.

When checking an individual load cell, it must be completely disconnected from the scale's electrical circuit. To accomplish this, the wires will need to be taken apart at the farmbar cable splice. See Figure 6-1 for the wiring of a farmbar system. The circuit diagram for the Load Cells of a *U Series* farmbar system is shown in Figure 7-1. Remember that each load cell contains four wires. All four wires must be disconnected to separate that load cell from the circuit.

Take apart the cable splices and take a resistance reading across each of the load cells. The cell resistance should be 350Ω. If you find that the reading for the cell is larger than 350Ω, or an open circuit, the cell may have to be replaced. If you getting an incorrect reading from load cells I and II in the slave bar, check the cable which connects the to bars for continuity.

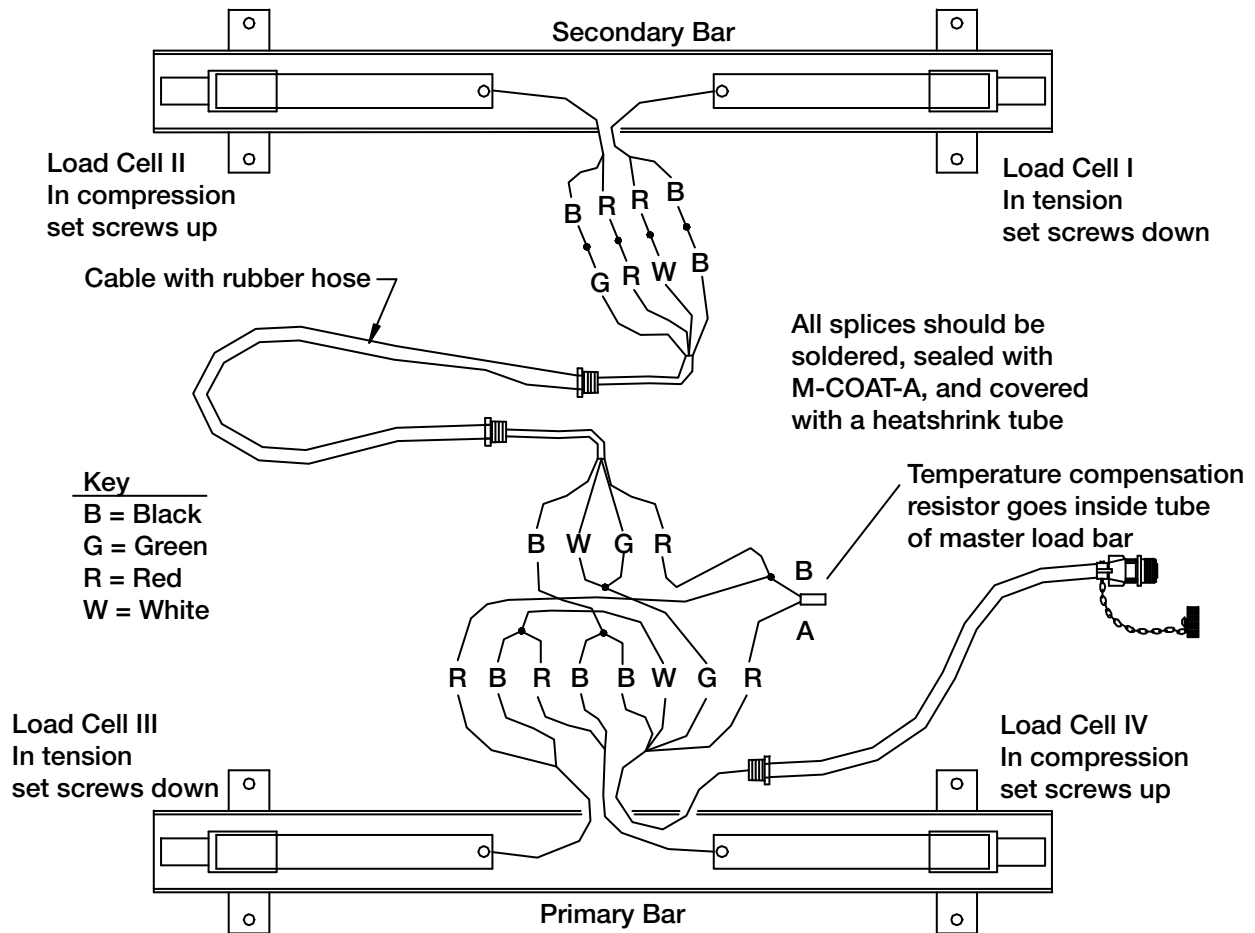

Figure 6-1. Farmbar System Wiring diagram

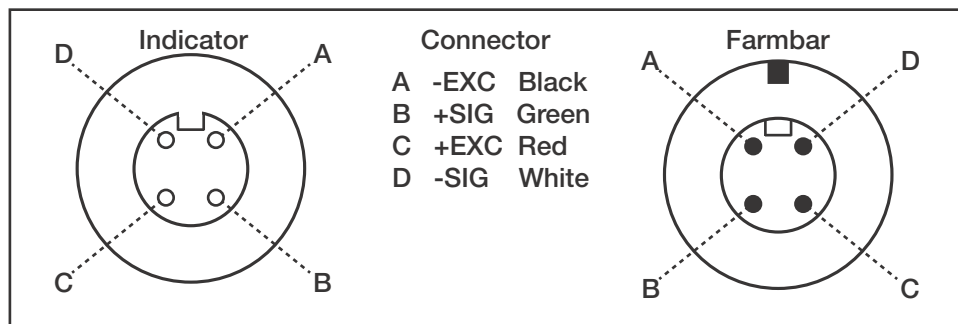

Figure 6-2. Farmbar System Connection

7.0 Load Cell Replacement

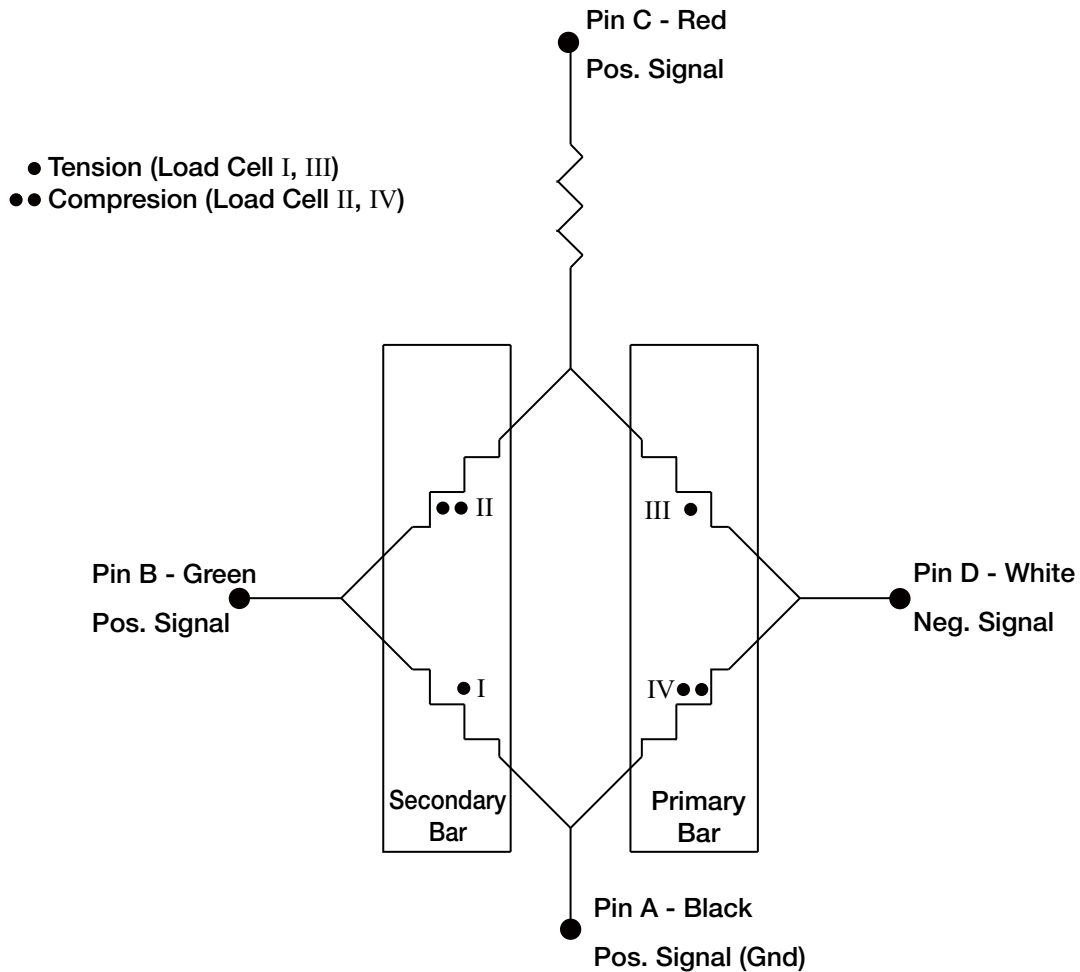

Figure 7-1. System Schematic

If load cell replacement is necessary, follow this procedure. Tie some string or wire around the end of the cable for the load cell being replaced. This string will be used to feed the new load cell cable through the bar and to the splicing junction when installing the new cell. Remove the one mounting bolt that holds the cell in place. Remove the cell and cable with the attached string. Check for physical damage to the cell and cable. If the cable is damaged, it may be replaced by splicing it together.



Note

Figure 7-1 gives the position for the set screws that hold the bearing collars in place. The set screw positions are NOT all the same! When replacing a cell, you must place the load cell in with the set screws having proper orientation. If the cell is installed upside down, the scale will not work properly.

U Series Limited Warranty

Rice Lake Weighing Systems (RLWS) warrants that all RLWS equipment and systems properly installed by a Distributor or Original Equipment Manufacturer (OEM) will operate per written specifications as confirmed by the Distributor/OEM and accepted by RLWS. All systems and components are warranted against defects in materials and workmanship for two years.

RLWS warrants that the equipment sold hereunder will conform to the current written specifications authorized by RLWS. RLWS warrants the equipment against faulty workmanship and defective materials. If any equipment fails to conform to these warranties, RLWS will, at its option, repair or replace such goods returned within the warranty period subject to the following conditions:

- Upon discovery by Buyer of such nonconformity, RLWS will be given prompt written notice with a detailed explanation of the alleged deficiencies.
- Individual electronic components returned to RLWS for warranty purposes must be packaged to prevent electrostatic discharge (ESD) damage in shipment. Packaging requirements are listed in a publication, *Protecting Your Components From Static Damage in Shipment*, available from RLWS Equipment Return Department.
- Examination of such equipment by RLWS confirms that the nonconformity actually exists, and was not caused by accident, misuse, neglect, alteration, improper installation, improper repair or improper testing; RLWS shall be the sole judge of all alleged non-conformities.
- Such equipment has not been modified, altered, or changed by any person other than RLWS or its duly authorized repair agents.
- RLWS will have a reasonable time to repair or replace the defective equipment. Buyer is responsible for shipping charges both ways.
- In no event will RLWS be responsible for travel time or on-location repairs, including assembly or disassembly of equipment, nor will RLWS be liable for the cost of any repairs made by others.

THESE WARRANTIES EXCLUDE ALL OTHER WARRANTIES, EXPRESSED OR IMPLIED, INCLUDING WITHOUT LIMITATION WARRANTIES OF MERCHANTABILITY OR FITNESS FOR A PARTICULAR PURPOSE. NEITHER RLWS NOR DISTRIBUTOR WILL, IN ANY EVENT, BE LIABLE FOR INCIDENTAL OR CONSEQUENTIAL DAMAGES.

RLWS AND BUYER AGREE THAT RLWS' SOLE AND EXCLUSIVE LIABILITY HEREUNDER IS LIMITED TO REPAIR OR REPLACEMENT OF SUCH GOODS. IN ACCEPTING THIS WARRANTY, THE BUYER WAIVES ANY AND ALL OTHER CLAIMS TO WARRANTY.

SHOULD THE SELLER BE OTHER THAN RLWS, THE BUYER AGREES TO LOOK ONLY TO THE SELLER FOR WARRANTY CLAIMS.

NO TERMS, CONDITIONS, UNDERSTANDING, OR AGREEMENTS PURPORTING TO MODIFY THE TERMS OF THIS WARRANTY SHALL HAVE ANY LEGAL EFFECT UNLESS MADE IN WRITING AND SIGNED BY A CORPORATE OFFICER OF RLWS AND THE BUYER.

© Rice Lake Weighing Systems, Inc. Rice Lake, WI USA. All Rights Reserved.

RICE LAKE WEIGHING SYSTEMS • 230 WEST COLEMAN STREET • RICE LAKE, WISCONSIN 54868 • USA

For More Information

Web Site

- <http://www.ricelake.com/products/livestock-solutions>

Hours of Operation

Knowledgeable customer service representatives are available 6:30 a.m. - 6:30 p.m. Monday through Friday and 8 a.m. to 12 noon on Saturday. (CST)

Contact Information

Telephone

- Sales/Technical Support 800-472-6703
- Canadian and Mexican Customers 800-321-6703
- International 715-234-9171

Immediate/Emergency Service

For immediate assistance call toll-free 1-800-472-6703 (Canadian and Mexican customers please call 1-800-321-6703). If you are calling after standard business hours and have an urgent scale outage or emergency, press 1 to reach on-call personnel.

Fax

Fax Number 715-234-6967

Email

US sales and product information at

- prodinfo@ricelake.com

International (non-US) sales and product information at

- intlsales@ricelake.com

Mailing Address

Rice Lake Weighing Systems

230 West Coleman Street

Rice Lake, WI 54868 USA



230 W. Coleman St. Rice Lake, WI 54868 USA
U.S. 800-472-6703 Canada/Mexico 800-321-6703 International 715-234-9171 Europe +31 (0) 88 2349171

www.ricelake.com www.ricelake.mx www.ricelake.eu www.ricelake.co.in m.ricelake.com

© Rice Lake Weighing Systems 127468 Rev B 08/2013